

website : <http://www.LGService.com>
e-mail : <http://LGService.com/techsup.html>

WASHING MACHINE SERVICE MANUAL

CAUTION

READ THIS MANUAL CAREFULLY TO DIAGNOSE TROUBLE
CORRECTLY BEFORE OFFERING SERVICE.

**MODEL : WD(M)-16220(5)FB/16220(5)FBB(N)
WD(M)-14220(5)FB/14220(5)FBB(N)
WD(M)-12220(5)FB/12220(5)FBB(N)
WD(M)-10220(5)FB/10220(5)FBB(N)**



CONTENTS

1. SPECIFICATION.....	3
2. FEATURES & TECHNICAL EXPLANATION	4
3. PARTS IDENTIFICATION	6
4. INSTALLATION	7
5. OPERATION.....	10
6. WIRING DIAGRAM / PROGRAM CHART	12
7. TROUBLESHOOTING.....	13
7-1.BEFORE PERFORMING SERVICE	13
7-2.QC TEST MODE.....	13
7-3.HOW TO KNOW THE WATER LEVEL FREQUENCY.....	13
7-4.ERROR DISPLAY	14
8. ERROR DIAGNOSIS AND CHECK LIST	16
8-1. DIAGNOSIS AND ANSWER FOR ABNORMAL OPERATION.....	16
8-2. FAULT DIAGNOSIS AND TROUBLESHOOTING	19
9. DISASSEMBLY INSTRUCTIONS	26
10. EXPLODED VIEW AND PARTS LIST	33
10-1. THE EXPLODED VIEW OF CABINET ASSEMBLY	33
10-2. THE EXPLODED VIEW OF CONTROL PANEL AND DISPENSER ASSEMBLY	34
10-3. THE EXPLODED VIEW OF DRUM AND TUB ASSEMBLY	35
※ APPENDIX (Replacement parts list)	36

1. SPECIFICATION

ITEM		WD(M)-16220(5)FB/16220(5)FBB(N) WD(M)-14220(5)FB/14220(5)FBB(N)	WD(M)-12220(5)FB/12220(5)FBB(N) WD(M)-10220(5)FB/10220(5)FBB(N)
POWER SUPPLY		220-240V~, 50Hz	
PRODUCT WEIGHT		65kg	
ELECTRICITY CONSUMPTION	WASHING	230W	
	SPIN (1400rpm)	440W	
	DRAIN MOTOR	38W	
	WASH HEATER	2000W	
REVOLUTION SPEED	WASH	45rpm	
	SPIN	1600 rpm : 400/800/1200/1600 rpm	
		1400 rpm : 400/800/1000/1400 rpm	
		1200 rpm : 400/800/1000/1200 rpm	
1000 rpm : 400/600/800/1000 rpm			
OPERATION WATER PRESSURE		0.3-10kgf/cm ² (30-1000kPa)	
CONTROL TYPE		Electronic	
WASH CAPACITY		Rating	
		Synthetic (3.5kg), Wool/Silk (2kg), Hand Wash (2kg), Delicate (3kg), Quick 30(5kg)	
DIMENSION		600mm(W) × 600mm(D) × 850mm(H)	
WASH PROGRAM		Cotton, Synthetic, Wool/Silk, Hand Wash, Delicate, Quick 30	
RINSE		Super, Normal, Rinse Hold	
DOOR SWITCH TYPE		Bi-Metal type	
WATER LEVEL		9 steps (by sensor)	
RESERVATION		From 3 hours to 19 hours	
SENSING OF THE LAUNDRY AMOUNT		Adapted	
FUZZY LOGIC		Adapted	
DISPLAY OF THE REMAINING TIME		Adapted	
ERROR DIAGNOSIS		9 items	
POWER AUTO OFF		Adapted	
CHILD LOCK		Adapted	
AUTO RESTART		Adapted	
RAPID		Adapted	

2. FEATURES & TECHNICAL EXPLANATION

2-1. FEATURES



■ Jumbo drum

LG's jumbo drum can wash about 40% more load than conventional washing machine. A bigger drum improves the wash performance.

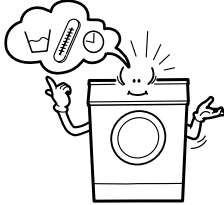

■ More economical by Intelligent Wash System

Intelligent Wash System detects the amount of load and water temperature, and then determines the optimum water level and washing time to minimize energy and water consumption.

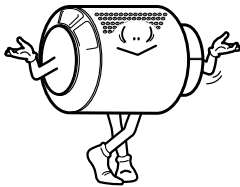

■ Direct Drive system

The advanced Brushless DC motor rotates the Drum directly without belt and pulley.

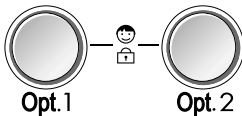

■ Child-Lock

The Child-Lock system has been developed to prevent children from pressing any button to change the program during operation.

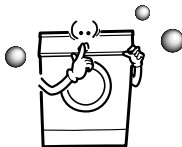

■ Low noise speed control system

By sensing the amount of load and balance, automatical distributes load evenly to minimize the spinning noise level.

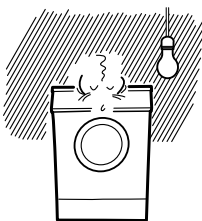

■ Auto Restart

Although the washing machine is turned off by a power failure, it restarts automatically where it stopped when power is supplied again. And it will be the same the machine is unplugged and is plugged in again.



■ Water circulation

Spray detergent solution and water onto the load over and over. Clothes are soaked more quickly and thoroughly during wash cycle. The detergent suds can be removed more easily by the water shower during rinse cycle. The water circulation system uses both water and detergent more efficiently.

2-2.DETERMINE WASHING TIME BY FUZZY LOGIC

To get the best washing performance optimal time is determined by sensing of water temperature, selected washing temperature and laundry amount.

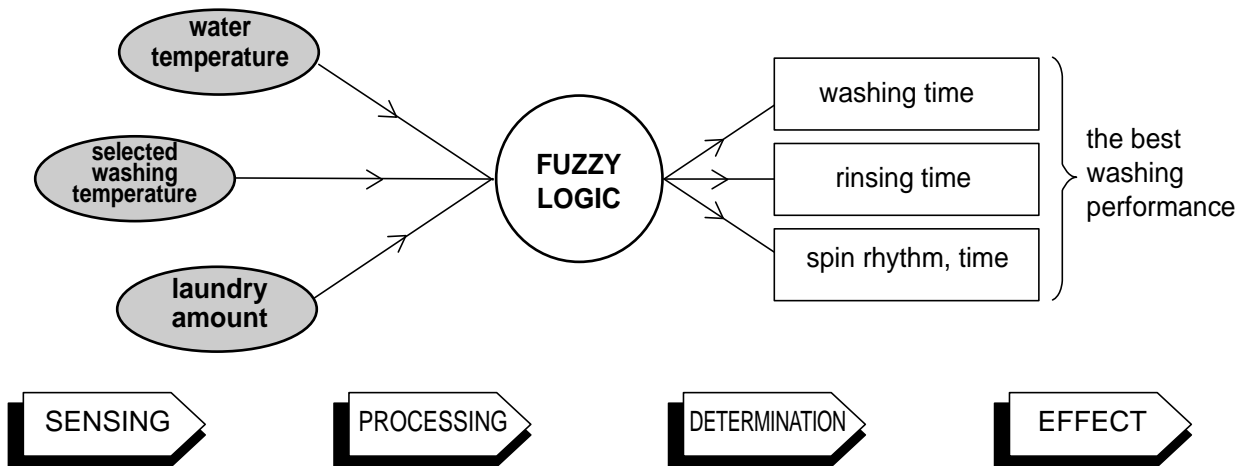

2-3.WATER LEVEL CONTROL

- This model adopts a pressure sensor which can sense the water level in the tub.
- Water supply is stopped when the water level to the preset level, then the washing program proceeds.
- Spinning does not proceed until the water in the tub reduces a certain level.

2-4.THE DOOR CAN NOT BE OPENED

- While program is operating.

3. PARTS IDENTIFICATION

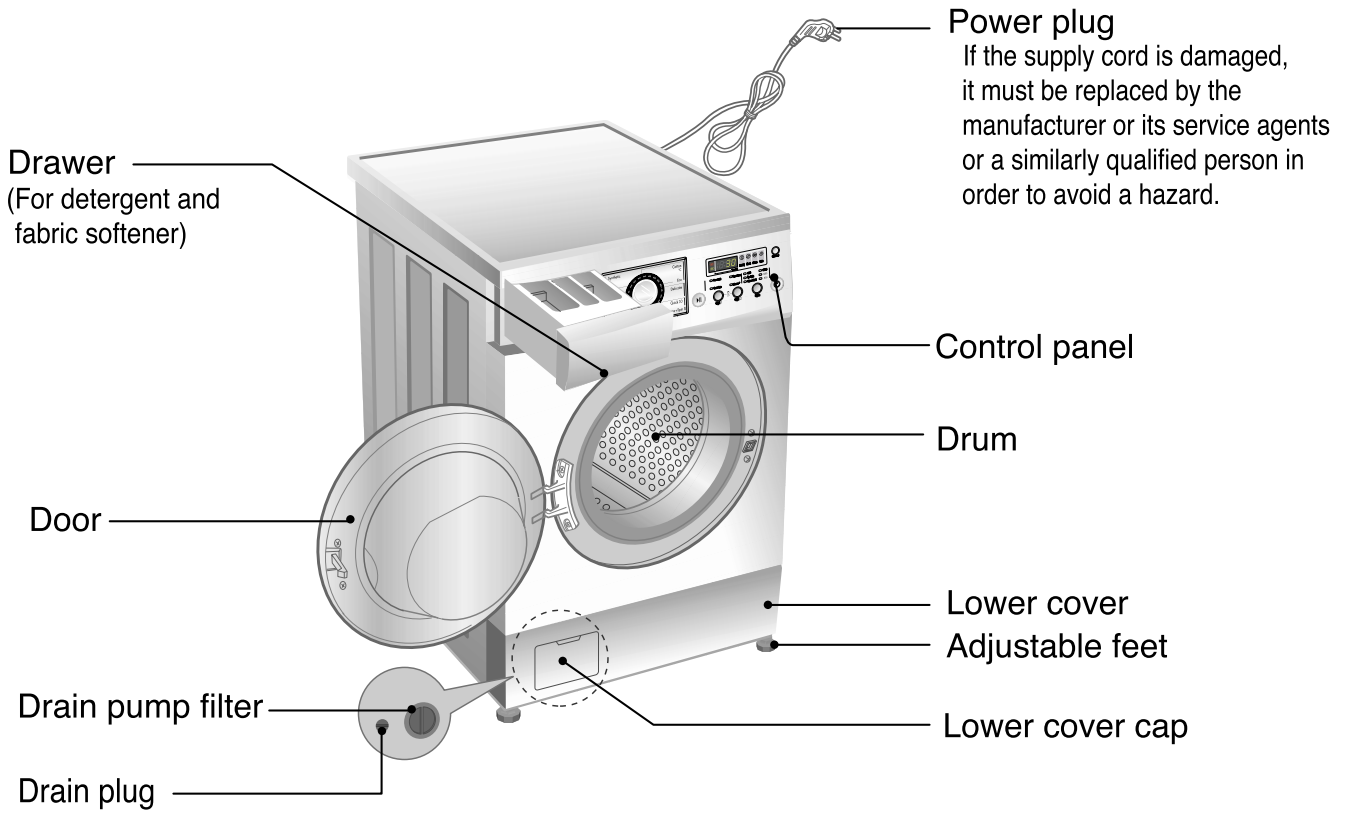

■ ACCESSORIES

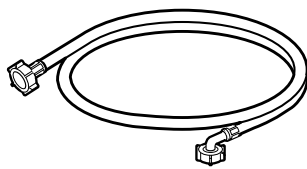

Inlet hose

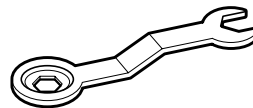

Wrench

4. INSTALLATION

- 1 Before servicing ask the customer what the trouble is.
- 2 Check the adjustment (power supply is 220-240V~, remove the transit bolts....)
- 3 Check the troubles referring to the troubleshooting.
- 4 Decide service steps referring to disassembly instructions.
- 5 Then, service and repair.
- 6 After servicing, operate the appliance to see whether it works O-K or NOT.

■ STANDARD INSTALLATION

The appliance should be installed as follows.

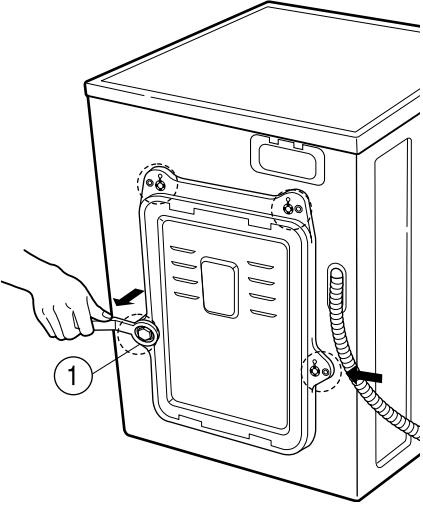
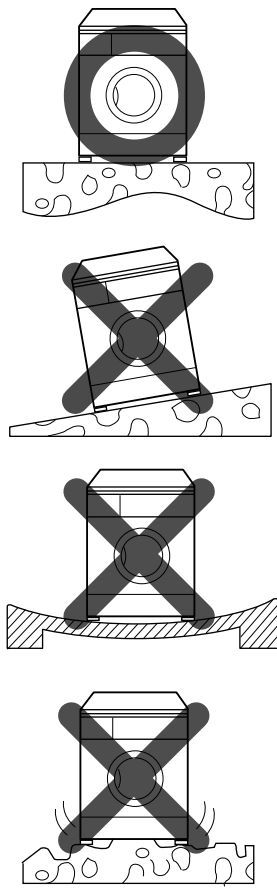
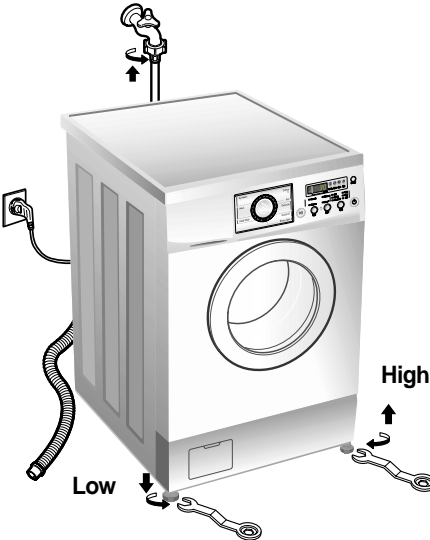
REMOVE THE TRANSIT BOLTS	INSTALL THE APPLIANCE ON FLAT AND FIRM SURFACE	ADJUST THE HORIZONTAL
<ul style="list-style-type: none"> • Remove the transit bolts (4EA: ①) with supplied spanner. • Keep the transit bolts and spanner for future use. • Insert the provided 4 caps into the hole 		<ul style="list-style-type: none"> • Turn the leveling feet to set the appliance horizontally.  <ul style="list-style-type: none"> • The appliance goes up by rotating the feet clockwise. • The appliance comes down by rotating the feet counter-clockwise.

■ HOW TO CONNECT INLET HOSE

- Check that the rubber washer is inside of the valve connector.
- Connect the inlet hose firmly to prevent leak.

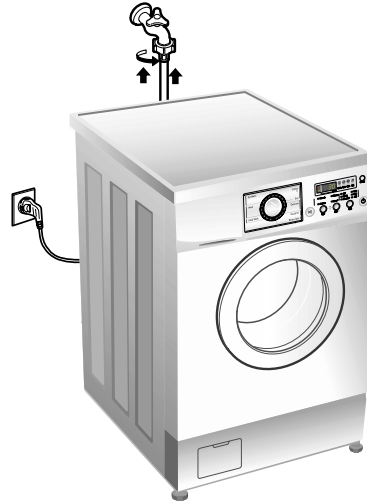

■ CONNECT DRAIN HOSE

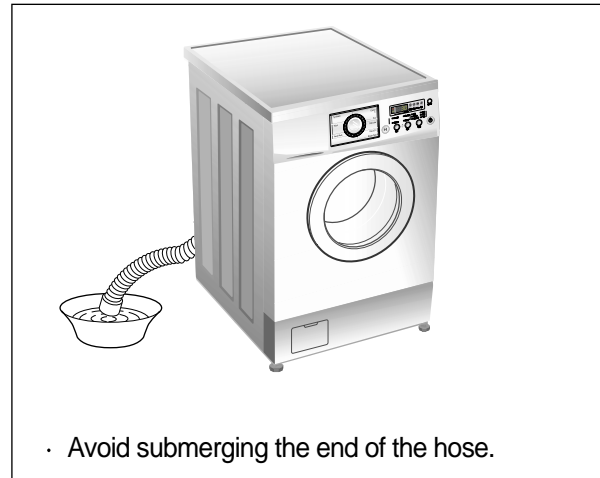
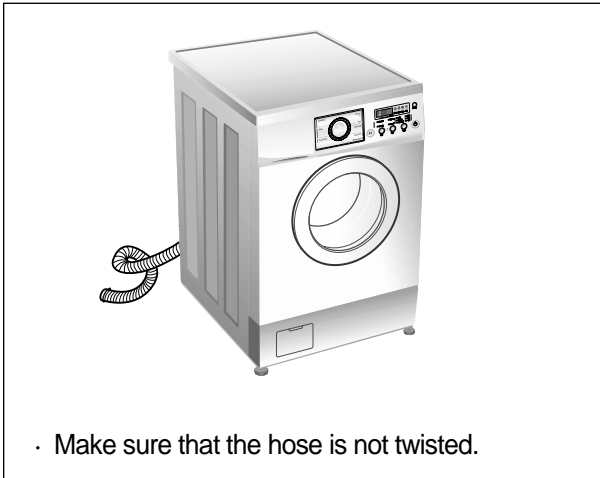

※ The drain hose should be placed under 100cm from the floor.

■ CONNECT POWER PLUG

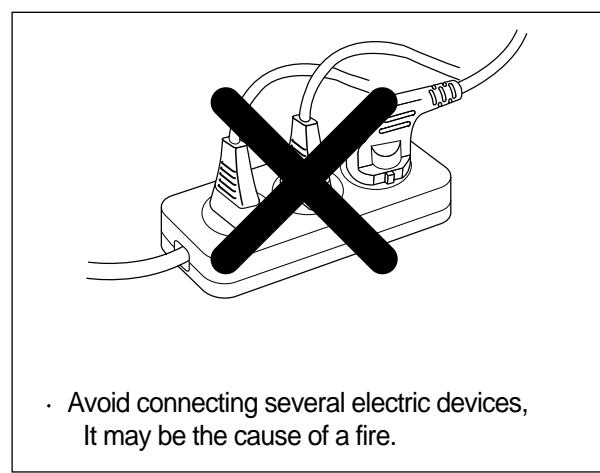
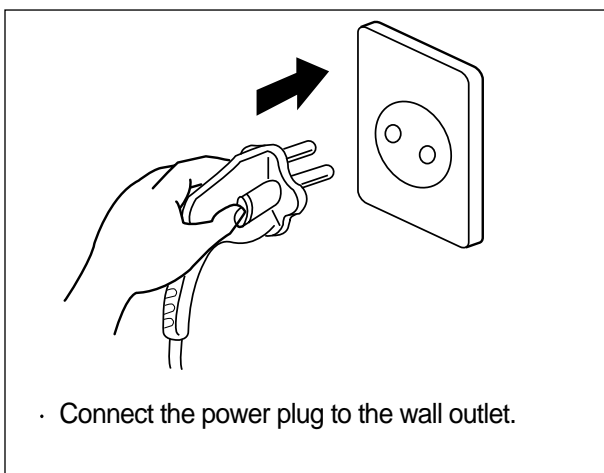

7 TEST OPERATION

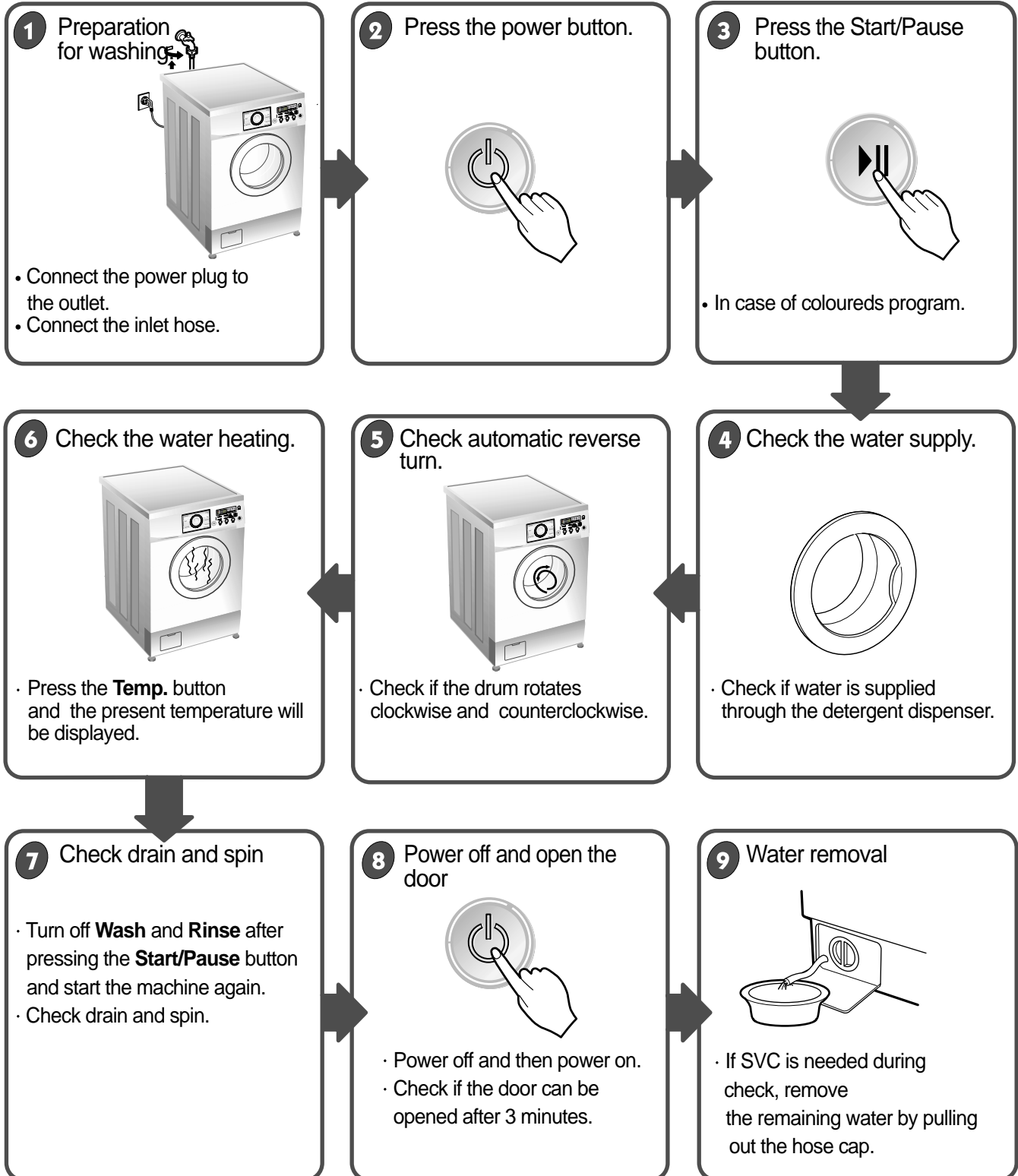

5. OPERATION

Wash program selector

- 8 program can be set depending on the type of the laundry.
- If the power button is pressed, Cotton program is automatically set.
- By turning the dial, [Cotton–Synthetic –Woo/Silk–Hand Wash – Drain–Rinse+Spin–Quick 30–Delicate]can be selected. (The opposite is possible)

LED display

- Display the estimated remaining time (Hour : Minute) to finish.
- In case of abnormal operation, error indications are displayed. (*1E, OE, UE, dE, tE, FE, PE, CE, LE,*)
- See troubleshooting guide.

Water temperature selector

- Press the button to select water temperature.
- 95°C is selected for Cotton only.
- By pressing the button while operating the washer, the present temperature is displayed.

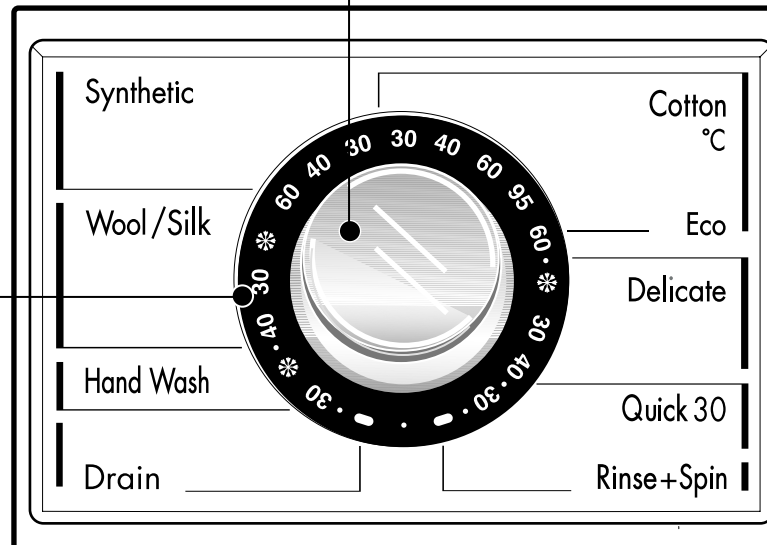

Start/Pause button

- Use the button to start or pause wash cycle.
- The power turns off automatically 4 minutes after the pause button is pressed.

Option1

Pre Wash

- If the laundry is heavily soiled, "Pre Wash" course is effective.
- Pre Wash is available in Cotton and Synthetic Program.

Crease Care

- If you want to prevent crease, select this button with spin

Time Delay

- Press the button when delayed washing is needed.
- When the button is pressed, 3:00 is displayed, maximum delay of 19:00 hours can be set.
- Each press advances time delay by the hour.
- Use [Power] button to cancel [Time Delay]
- [Time Delay] means the time required from the present to the completion of washing.

Child - Lock

- **Child Lock** system can be set and canceled by pressing and holding both [Option1] and [Option 2] button simultaneously more than 2 seconds.
- Once **Child Lock** is set, all buttons are inoperable except power button.
- **Child Lock** system can be set anytime even during Power-off and operation.
- It is automatically cancelled when an operational error occur.

Power button

- Press the button to turn power on and off.
- Press the button to cancel the delay finish.

Spin button

- By pressing the Spin button the spin speed can be chosen.

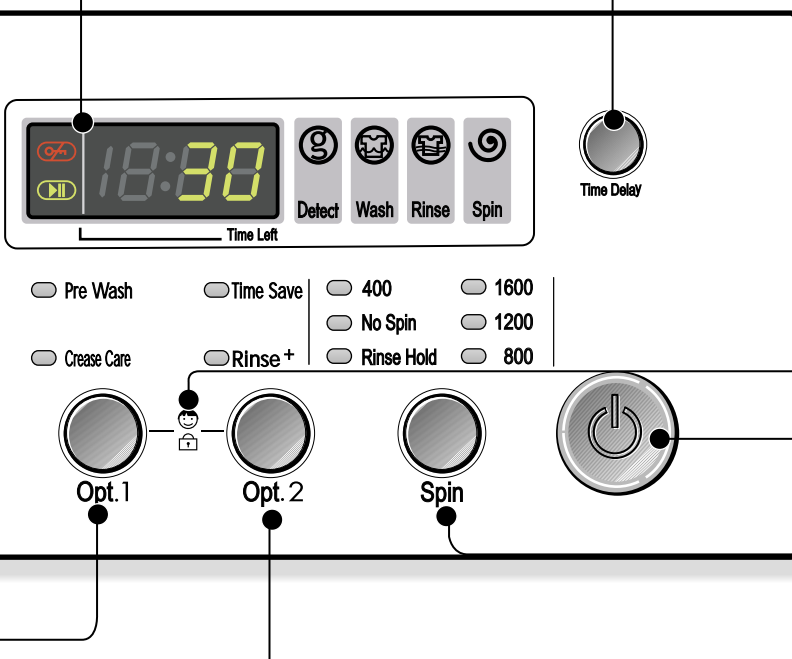

Option2

Time Save

- By selecting the Time Save option, the wash time may be reduced, depending on the program selected.
- This option is available with Cotton, Synthetic program.

Rinse+

- If you wish to rinse more, the Rinse+ option will remove any trace of detergents.

6. WIRING DIAGRAM / PROGRAM CHART

* Water Supply : W·S * Intermittent Spin : I·S * Disentangle : D·T

CYCLE STEP COURSE Time (SEC)	Washing										Rinse								Spin			A U T O O F F	Normal Working Time (Hour:Minute)										
	Pre				Main						Normal				Rinse +				Drain	Spin	D·T												
	W·S	Washing	Drain	I·S	W·S	Washing		Staycooling		Drain	I·S	W·S	Rinsing	Drain	I·S	W·S	Rinsing	Drain						I·S	W·S	Rinsing							
						Heating	Washing	W·S	Rinsing										1	2	3						4						
1	2	3	4	5	6	7	8	9	10	11	12	13	14	15	16	17	18	19	20	21	22	23	24	25	26	27	28	29	20	20			
Cotton(BIG)		8				42																									20	20	About 2:45
Cotton(Small)		8				42																											About 2:41
Synthetic						47																										About 1:29	
Delicate						26																										About 1:03	
Wool/Silk						51																										About 1:01	
Handwash						4																										About 55	
Quick						18																										About 30	
Rinsing + Spin						4																										About 20	
Drain						18																										About 1	

- * Basic Cycle
- * Optional Cycle
- * Pre-Setting Time : Water Supply - 120 sec.
Drain - 60 sec.
- * ~ Time for varies as the temperature or the amount of laundry
- * Basic time is minute in washing chart
- * The actual program time can be varied with the load amount, water temperature or ambient temperature

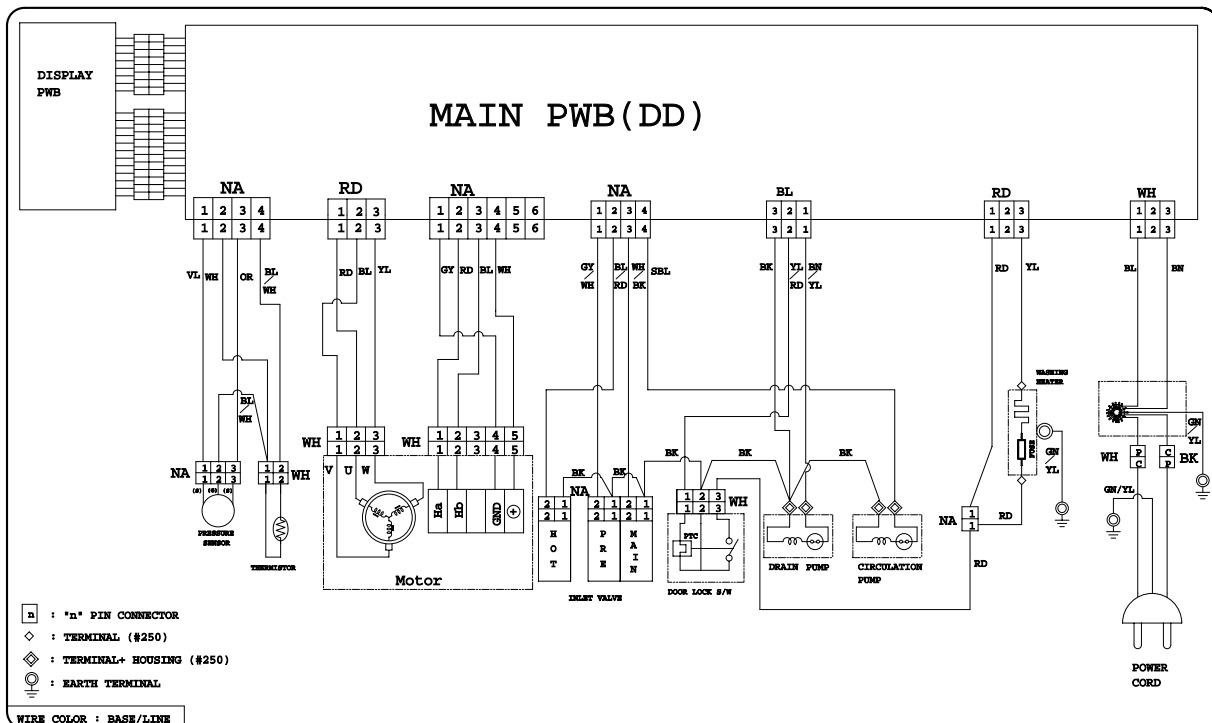

7. TROUBLESHOOTING

7-1. BEFORE PERFORMING SERVICE

- Be careful of electric shock or disconnecting the parts while troubleshooting.
- Voltage of each terminal in 220-240V~ and DC while applying an electric current.

7-2. QC TEST MODE.

- ① Pressing **Option1**, and **Spin** button simultaneously.
- ② Power supply on with pressing upper two button. Then buzzer sound twice.
- ③ Press the Start/Pause button as follows.

[Press the Start/Pause button more 4 times until stop spinning]

Pressing number of [Start/Pause] button	Checking Point	Display Status
None	All lamps turn on	
1 time	Clockwise spin (right)	Drum rpm (About 40~50)
2 times	Low speed Spin	Drum rpm (About 53~65)
3 times	High speed Spin	Drum rpm (About 140~160)
4 times	Inlet valve for prewash operation	Water level frequency (25~65)
5 times	Inlet valve for mainwash operation	Water level frequency (25~65)
	Hot inlet valve in case of hot water fill	
6 times	Inlet valve for mainwash operation	Water level frequency (25~65)
7 times	Counterclockwise spin (left)	Drum rpm (About 40~50)
8 times	Heater is in operation for 3 sec.	Water temperature
9 times	Circulation pump operation	Water level frequency
10 times	Draining pump operation	Water level frequency
11 times	Auto off operation	

7-3. HOW TO KNOW THE WATER LEVEL FREQUENCY

* Press the **Rinse** and **Spin** button simultaneously.

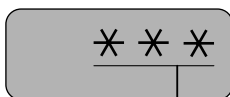



● The digits means water level frequency (10^{-1} kHz)

$$\text{ex) } 241 : \text{Water level frequency} = 241 \times 10^{-1} \text{ kHz} \\ = 24.1 \text{ kHz}$$

7-4.ERROR DISPLAY.







- If you press the Start/Pause button when an error is displayed, any error except **PE** will disappear and the machine will change into pause status.
- In case of **PE** , **LE** , **DE** , if the error is not resolved within 20 sec. In the case of other errors, if the error is not resolved within 4 min., power will be turned off automatically and the error only will be blinked. But in the case of **FE** , power will not be turned off.

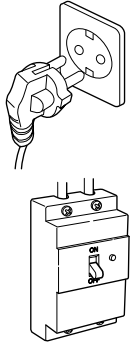

	ERROR	SYMPTOM	CAUSE
1	WATER INLET ERROR		<ul style="list-style-type: none"> ○ Water has not reached to the pre-set level within 8 min. since inlet valve operated, or water has not reached to the normal level within 25 min.
2	IMBALANCE ERROR		<ul style="list-style-type: none"> ○ Load is too small. ○ The appliance is tilted. ○ Laundry is gathered to one side. ○ Non-distributable things are put into the drum.
3	DRAIN ERROR		<ul style="list-style-type: none"> ○ Water has not drained enough within 10 min.
4	OVERFLOW ERROR		<ul style="list-style-type: none"> ○ Water is automatically being pumped out because too much water is in the tub.
5	SENSOR PRESSURE S/W ERROR		<ul style="list-style-type: none"> ○ The sensor pressure switch is out of order.
6	DOOR OPEN ERROR		<ul style="list-style-type: none"> ○ The Start/Pause button is pressed with the door open. ○ The door switch is out of order.
7	HEATING ERROR		<ul style="list-style-type: none"> ○ The THERMISTOR is out of order.

	ERROR	SYMPTOM	CAUSE
8	CURRENT ERROR		<ul style="list-style-type: none"> • MAIN PWB ASSEMBLY is out of order <ul style="list-style-type: none"> ☞ Replace the MAIN PWB ASSEMBLY • Winding in the STATOR ASSEMBLY is short-circuited. <ul style="list-style-type: none"> ☞ Replace the STATOR ASSEMBLY
9	LOCK ERROR		<ul style="list-style-type: none"> • The connector (3-pin, male, white) in the LEAD WIRE ASSEMBLY is not connected to the connector (3-pin, female, white) of STATOR ASSEMBLY. <ul style="list-style-type: none"> ☞ Reconnect or repair the connector • The electric contact between the connectors [3-pin, male, white in the LEAD WIRE ASSEMBLY and 4-pin, female, natural in the MAIN PWB ASSEMBLY is bad or unstable. <ul style="list-style-type: none"> ☞ Reconnect or repair the contact in the connector • The LEAD WIRE ASSEMBLY between the STATOR ASSEMBLY and MAIN PWB ASSEMBLY is cut (open circuited). <ul style="list-style-type: none"> ☞ Repair the damaged (open-circuited) the LEAD WIRE ASSEMBLY • The hall sensor is out of order/defective. <ul style="list-style-type: none"> ☞ Replace the STATOR ASSEMBLY

8. ERROR DIAGNOSIS AND CHECK LIST

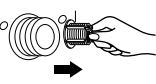
8-1. DIAGNOSIS AND ANSWER FOR ABNORMAL OPERATION

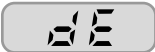
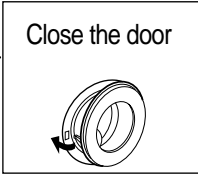
SYMPTOM	GUIDE FOR SERVICE CALL	
<p>NO POWER</p>	<p>Is the power plug connected firmly to 220-240V~ outlet?</p> <p style="text-align: center;">YES</p> <p>Power failure? or Breaker opened? Is the outlet controlled by a switch</p> <p style="text-align: center;">NO</p> <p style="text-align: center;">Visit to check</p>	
<p>WATER INLET TROUBLE</p> 	<p>Is  displayed?</p> <p style="text-align: center;">YES</p> <p>Is the tap opened?</p> <p style="text-align: center;">YES</p> <p>Is the tap frozen?</p> <p style="text-align: center;">NO</p> <p>Is the water supply shut-off?</p> <p style="text-align: center;">NO</p> <p>Is filter in the inlet valve clogged with foreign material?</p> <p style="text-align: center;">YES</p> <p style="text-align: center;">NO</p> <p style="text-align: center;">Visit to check</p>	    <div style="border: 1px solid black; padding: 5px; width: fit-content;"> <p>Clean the filter of inlet valve</p>  </div>

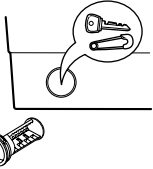
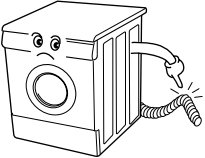
SYMPTOM	GUIDE FOR SERVICE CALL
<p>◦ DOOR OPEN ERROR</p> 	<p>Did you press the Start/Pause button when the door is open?</p> <p>YES → Close the door</p>  <p>NO → Visit to check</p> <p>Check if the door switch is O.K</p>
<p>◦ DRAIN TROUBLE</p> 	<p>Is  displayed?</p> <p>YES → Is the debris filter clogged with foreign material such as pins, coins, etc?</p> <p>YES → Clean up the filter.</p>  <p>NO → Is the drain hose frozen with water, kinked, or crushed?</p> <p>NO → Visit to check</p> 

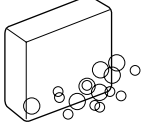
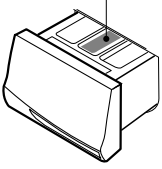
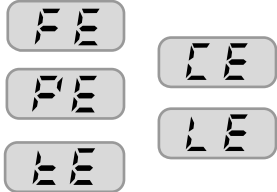
SYMPTOM	GUIDE FOR SERVICE CALL
<p>◦ Suds overflow from the appliance. (In this condition, wash and spin do not operate normally)</p>	<div style="display: flex; justify-content: space-between;"> <div style="width: 65%;"> <p>Is low-sudsing detergent for the drum washing machine used?</p> <p style="text-align: center;">YES</p> <p>Is the proper amount of detergent used as recommended?</p> <p style="text-align: center;">YES</p> <p>Recommend to reduce the amount of detergent.</p> <ul style="list-style-type: none"> * This appliance has the automatic suds sensing function which operates under much suds condition for good rinse and preventing overflow. * When much suds are sensed, the suds removing function such as drain, water input, and pause will operate without rotating the drum. </div> <div style="width: 30%; text-align: center;">  <p>LOW-SUDSING DETERGENT</p> </div> </div>
<p>◦ No effect of softener</p>	<div style="display: flex; justify-content: space-between;"> <div style="width: 65%;"> <p>Is softener put in the correct compartment of the drawer?</p> <p style="text-align: center;">YES</p> <p>Is the drawer closed during wash?</p> <p style="text-align: center;">YES</p> <p>Is the softener cap clogged?</p> <p style="text-align: center;">YES</p> <p>Explain how to use softener</p> <p>Clean the compartment for softener</p> </div> <div style="width: 30%; text-align: center;"> <p>Compartment for softener</p>  </div> </div>
	<p style="text-align: center;">Visit to check</p>

8-2.FAULT DIAGNOSIS AND TROUBLESHOOTING

CAUTION

1. Be careful of electric shock or disconnecting the parts while troubleshooting.
2. First of all, check the connection of each part terminal with wiring diagram.
3. If you replace the MAIN PWB ASSEMBLY, put in the connectors correctly.

NO POWER

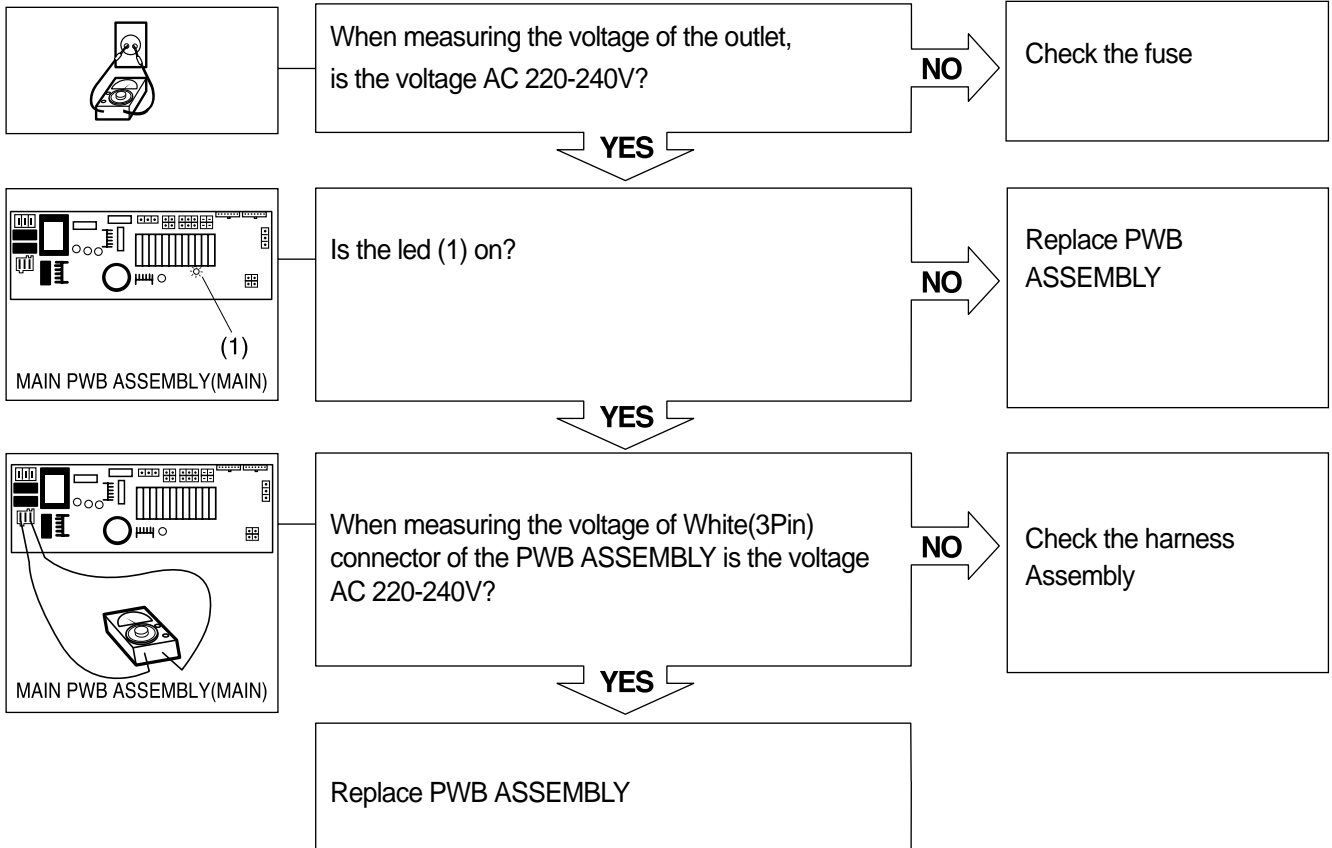

NO WATER SUPPLY

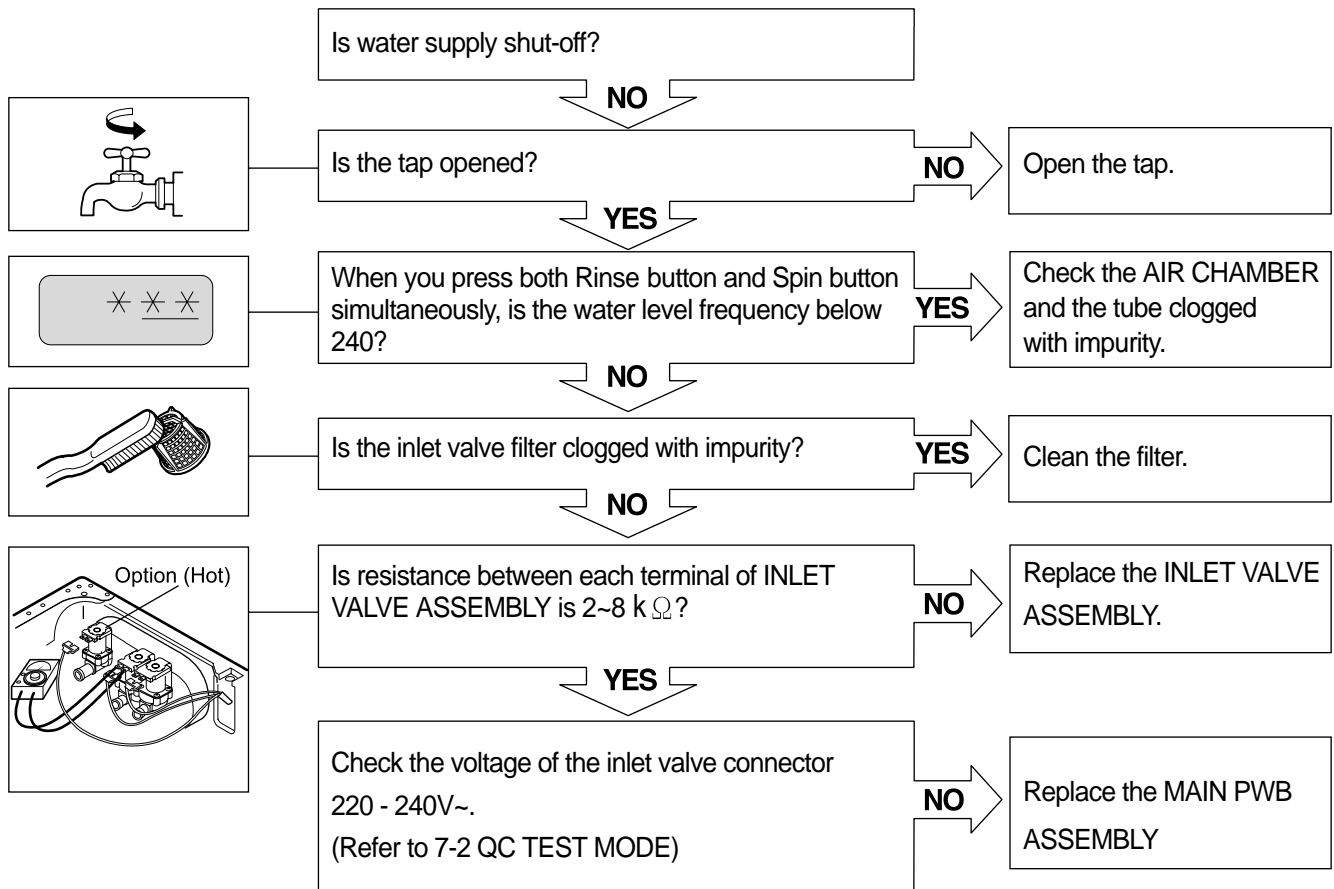

DETERGENT DOES NOT FLOW IN

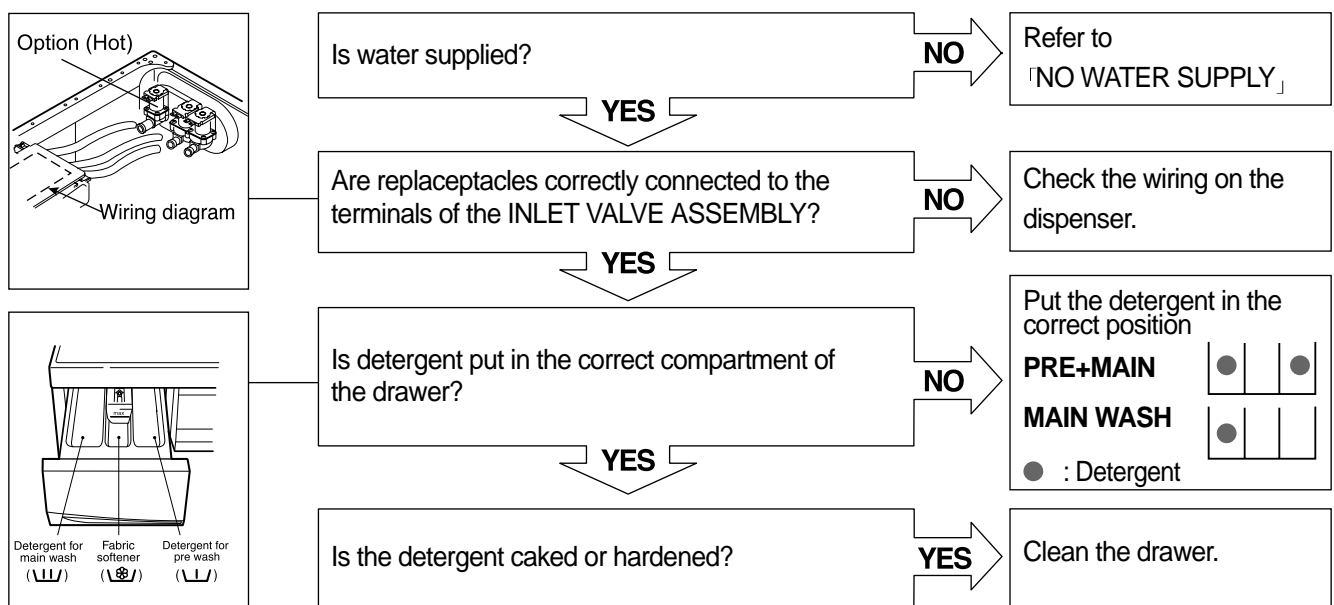

SOFTENER DOES NOT FLOW IN

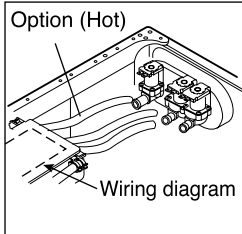

Is water supplied?

NO

Refer to
'NO WATER SUPPLY'

YES

Are receptacles correctly connected to the terminals
of the INLET VALVE ASSEMBLY?

NO

Check the wiring on the
dispenser.

YES

Is softener put in the correct compartment of the
drawer?

NO

Put it in the correct
compartment.

YES

Is the softener cap clogged?

YES

Clean the cap and
drawer.

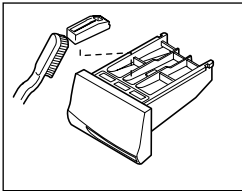
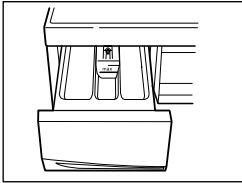

ABNORMAL SOUND

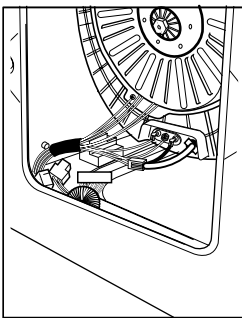

Is the motor bolt loosened?

YES

Fix the bolt tightly.

NO

Is there friction noise from the motor?

YES

Replace the STATOR
ASSEMBLY or ROTOR
ASSEMBLY.

HEATING WITHOUT WATER

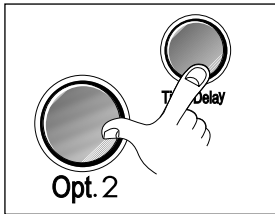

When pressing **Opt. 2** and **Time Delay** at the same time after draining, is the water level frequency 252 or more? When pressing **Opt. 2, Time Delay** buttons at the same time while wash, is the water level frequency between 230 - 243 ?

NO

Replace the S.PRESSURE SWITCH ASSEMBLY

YES

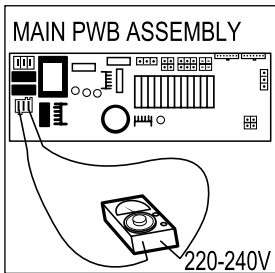

Checking voltage between two pins as press the **POWER** button is the voltage 220 - 240V~?

YES

Replace the MAIN PWB ASSEMBLY

DRAIN MALFUNCTIONING

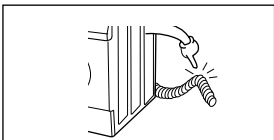

Is the drain hose twisted or frozen?

YES

Repair the DRAIN HOSE ASSEMBLY.

NO

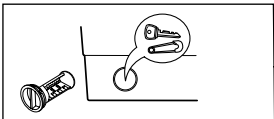

Is the impeller of the drain pump clogged?

YES

Remove foreign material.

NO

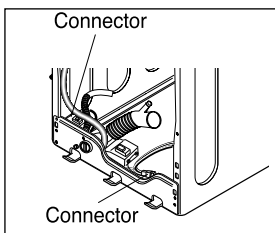

Is the connector disconnected, disassembled?

YES

Reconnect or repair the connector

NO

Is the coil of the drain pump cut-off?
(resistance of coil is 90~160 Ω)

YES

Repair the DRAIN PUMP ASSEMBLY.

NO

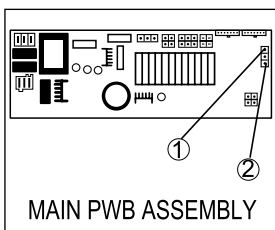

When checking voltage between connectors (①, ②) on spinning, is the voltage 220 - 240V~ as the figure?

NO

Repair the MAIN PWB ASSEMBLY.

WILL NOT CIRCULATE WATER

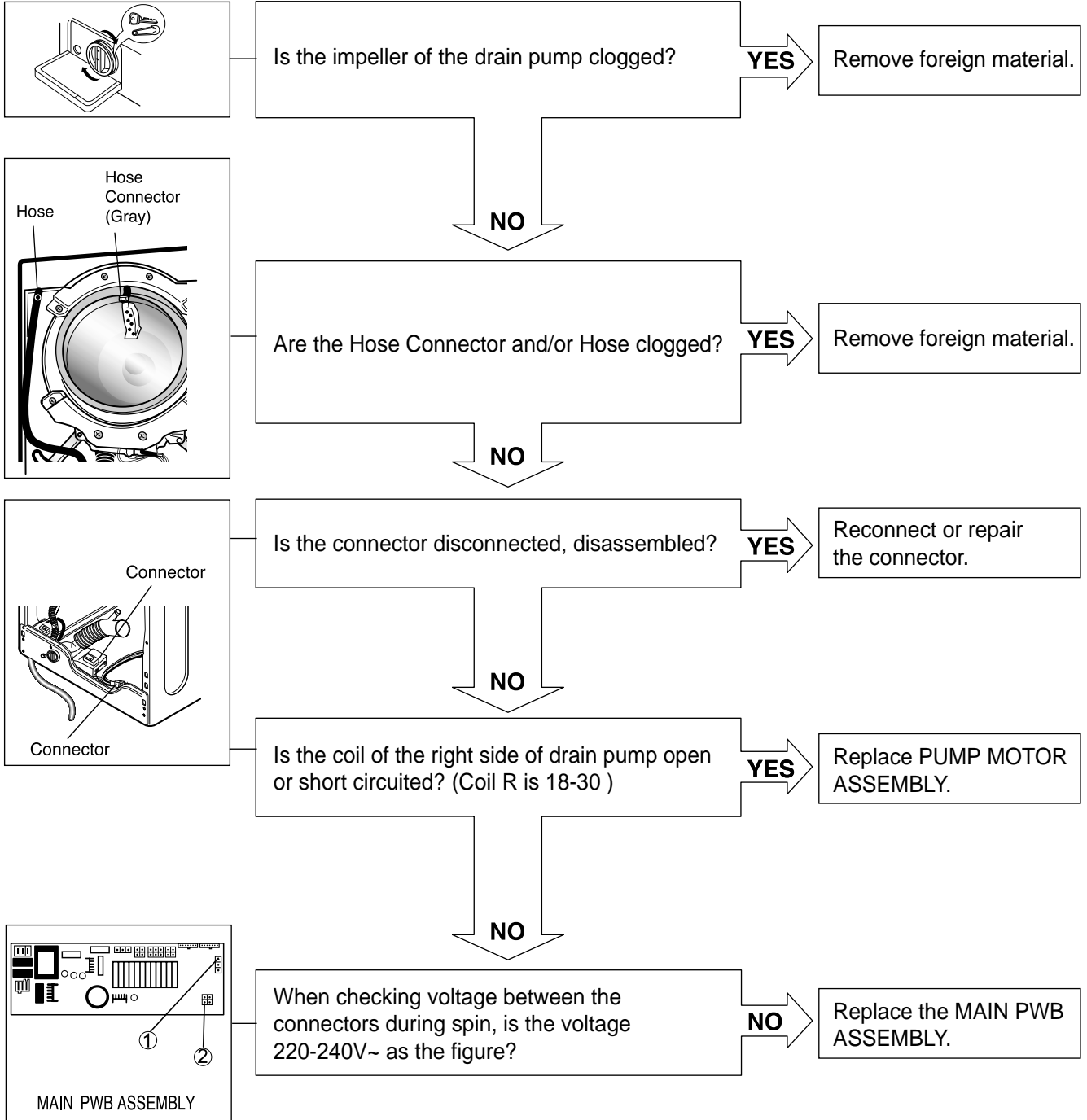

WASH HEATER TROUBLE

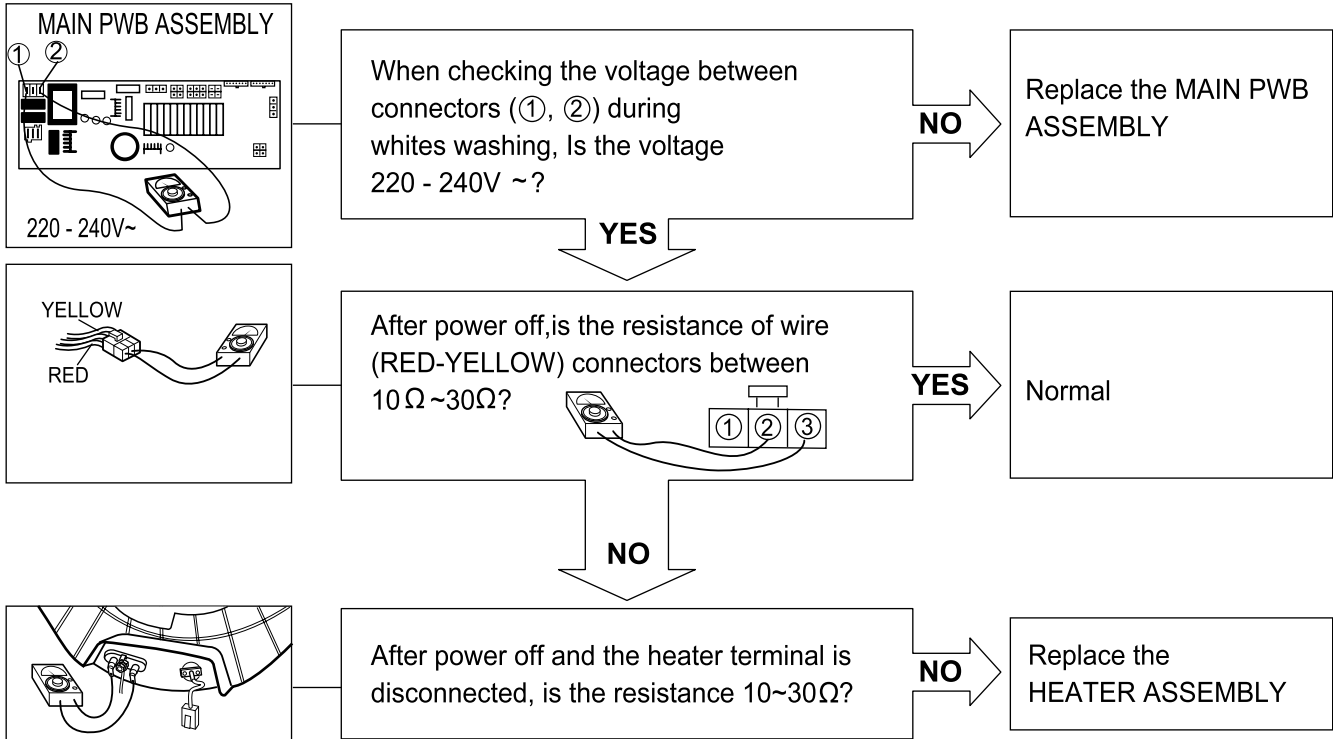

HEATING CONTINUOUSLY ABOVE THE SETTING WATER TEMPERATURE

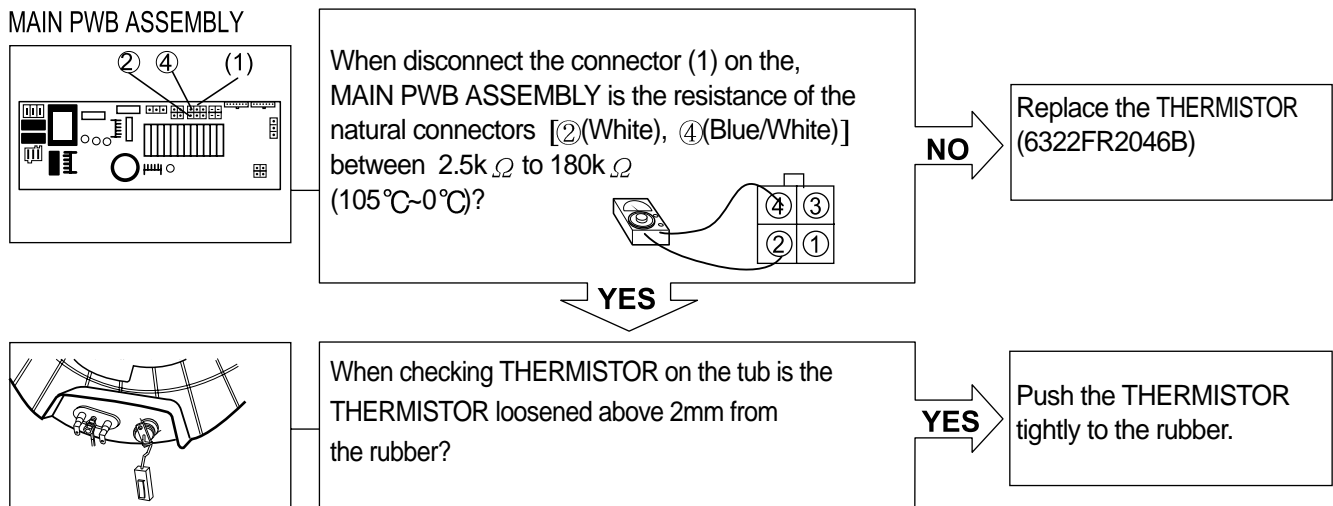

SPIN TROUBLE

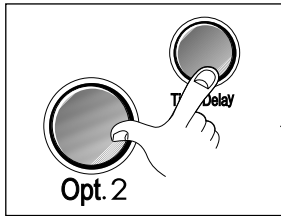

Check on the spinning, is the frequency of the water level 248 or more. The frequency can be checked by pressing the **Opt.2** and **Time Delay** buttons at the same time on the program.

NO

Check the sensor (Pressure) or hose (Sensor). If the problem is on the sensor or the hose, replace the sensor or the hose.

YES

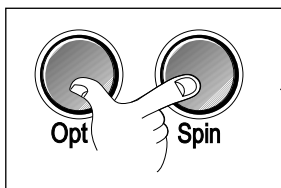

When pressing **Opt.2**, **Spin** and **POWER** buttons at the same time after power off, press the Start/Pause button 2 times, is the drum low speed spin?

YES

Normal

NO

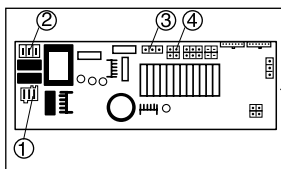

Is it disconnected, or disassembled?
[White : 3pin(①), Red:3pin(②), Red:3pin(③), National:6pin(④)]

YES

Correct the connector.

NO

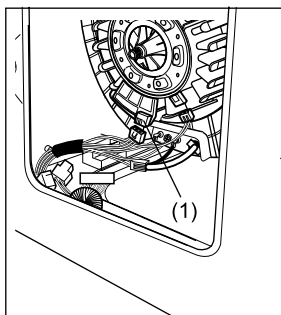

Is it disconnected, or disassembled?
[White:3pin (①), National:4pin (②)]

YES

Correct the connector.

NO

Check the motor connector, Is the resistance of the terminal same as the figure?

MOTOR TERMINAL (1)

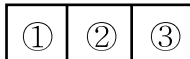

Resistance of terminal:

①~② / ②~③ / ③~① : About 5Ω ~10Ω

NO

Replace the STATOR ASSEMBLY (4417FA1994E)

YES

Replace the MAIN PWB ASSEMBLY

9. DISASSEMBLY INSTRUCTIONS

* Be sure to unplug the machine out of the outlet before disassembling and repairing the parts.

CONTROL PANEL ASSEMBLY

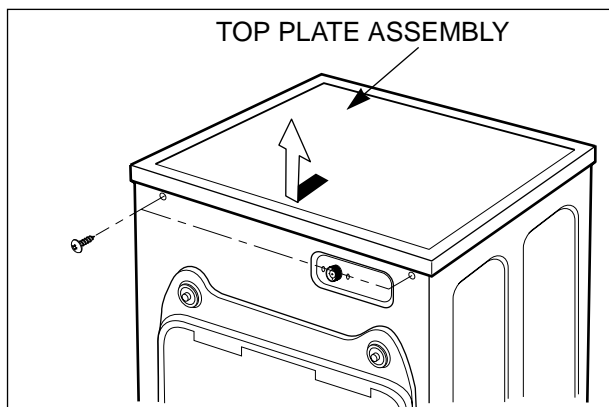

- ① Unscrew 2 screws on the back of the top plate.
- ② Pull the top plate backward and upward as shown.

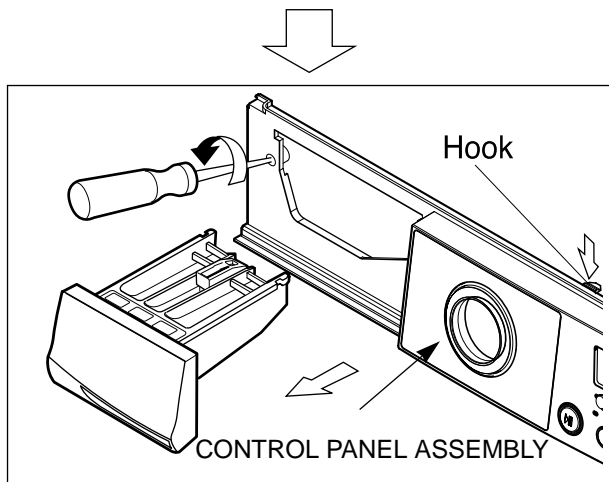

- ① Disconnect the ASSEMBLY connector.
- ② Pull out the drawer and unscrew 2 screws.
- ③ Push 2 upper hooks down and pull the control panel.

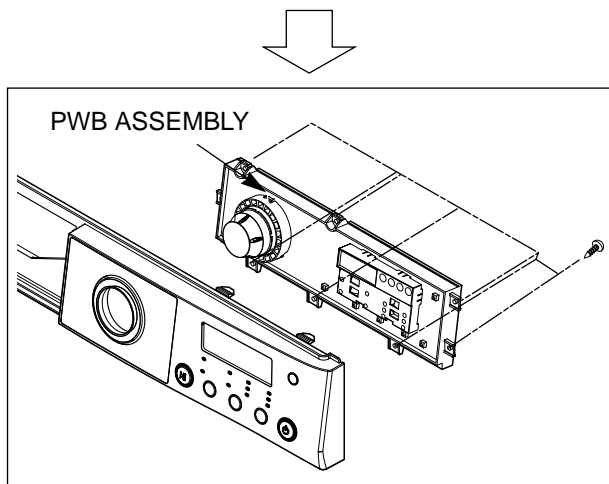

- ① Disconnect the PWB ASSEMBLY from the control panel by unscrewing 7 screws.

DISPENSER ASSEMBLY

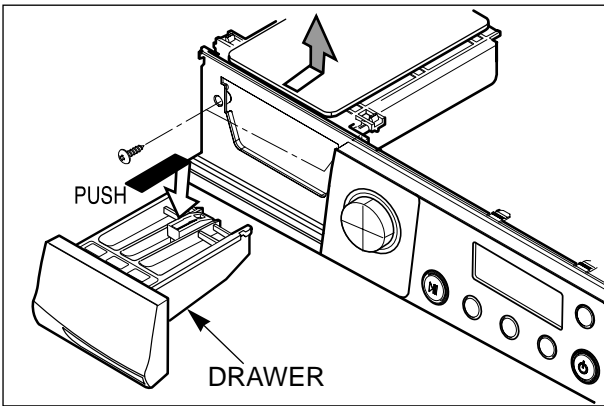

- ① Disassemble the TOP PLATE ASSEMBLY.
- ② Pull out the drawer slightly upward.
- ③ Unscrew 2 screws.

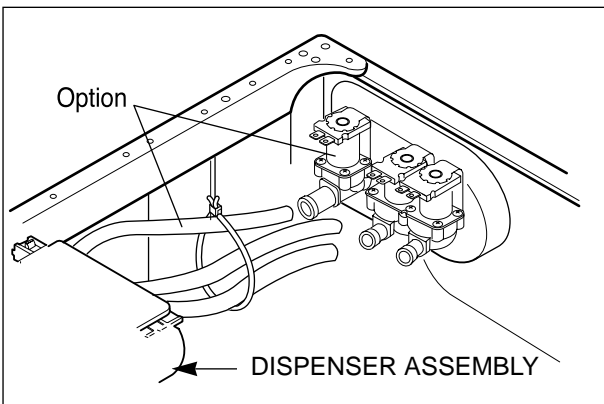

- ① Disassemble hose clamps and hoses.
- ② Disassemble the ventilation bellows and the water inlet bellows from the tub.

INLET VALVE ASSEMBLY

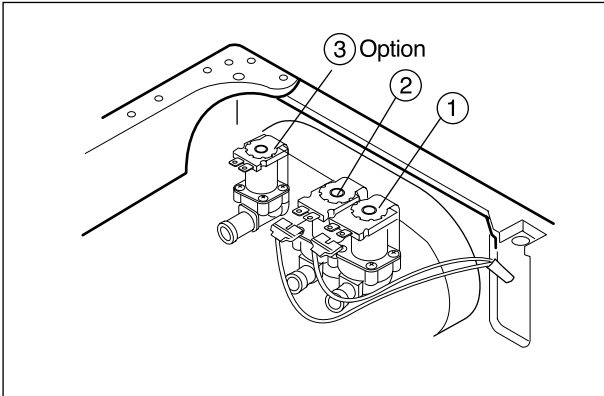

- ① Disconnect the wiring connector.
- ② Unscrew 2 screws from the back.

* When reconnecting the connector

* Cold only model

VALVE#1 (MAIN)	Whited/Black-Black
VALVE#2 (PRE)	Gray/ White - Black

* Cold and Hot model

VALVE #1 (MAIN)	Whited/Black-Black
VALVE #2 (PRE)	Gray/ White - Black
VALVE #3 (HOT)	Blue/Red - Black

LOWER COVER

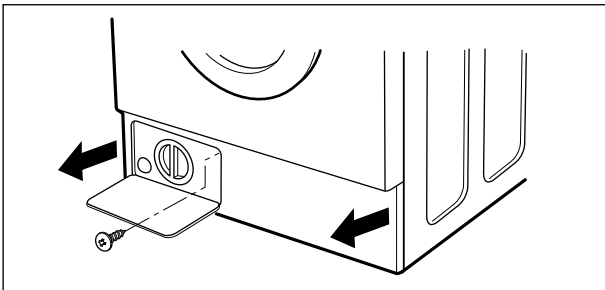

- ① Open the lower cover CAP by using coin and pull out the lower cover in the arrow direction after a screw is unscrewed.

DOOR ASSEMBLY

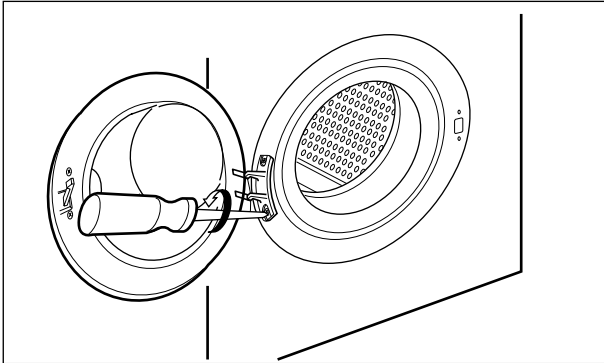

- ① Open the door completely.
- ② Remove the two screws from the hinge.

※ When removing the DOOR ASSEMBLY, it is necessary to hold the BRACKET that is inner of the CABINET COVER.

GASKET

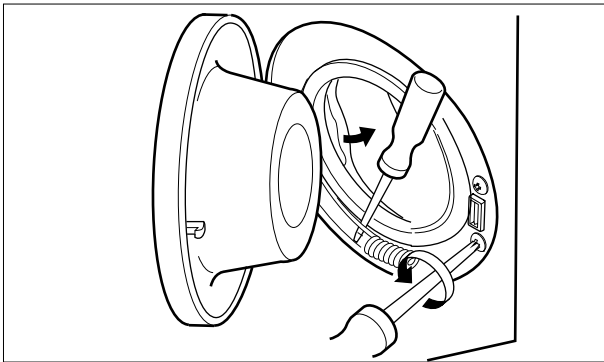

- ① Take apart the CLAMP ASSEMBLY (cabinet).
- ② Unscrew 2 screws from the CABINET COVER.
- ③ Open the lower cover cap and unscrew 1 screw inside
- ④ Take apart the LOWER COVER.

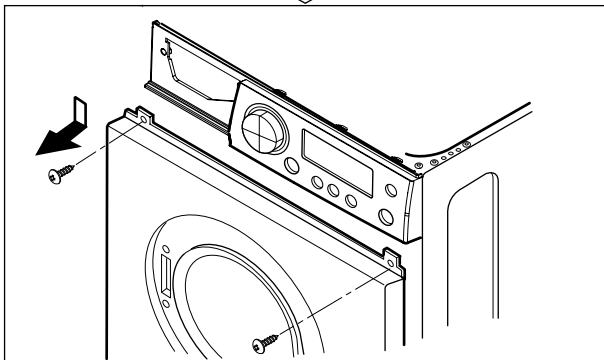

- ① Disassemble the CONTROL PANEL ASSEMBLY.
(Refer to page 26)
- ② Unscrew all the screws on the upper and lower sides of the CABINET COVER.

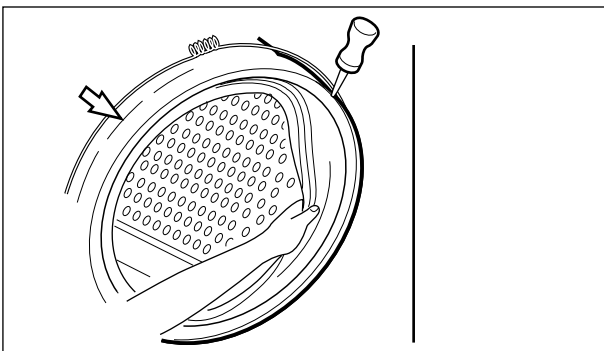

- ① Take apart the tub CLAMP ASSEMBLY
 - ② Make sure that the drain hole of the GASKET is put beneath when reassembling the GASKET.
- ※ Refer to the arrow mark on the TUB COVER.

ROTOR ASSEMBLY, STATOR ASSEMBLY, FRICTION DAMPER ASSEMBLY

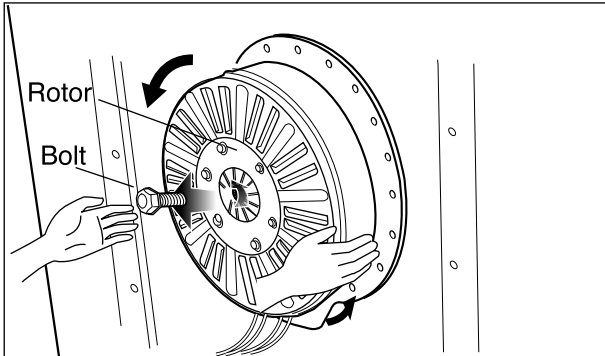

(ROTOR ASSEMBLY)

- ① Remove the BACK COVER.
- ② Unscrew the bolt to pull out the ROTOR ASSEMBLY.

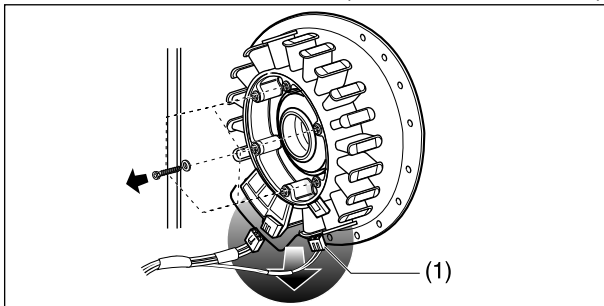

(STATOR ASSEMBLY)

- ① Disconnect the wiring connector.
- ② Unscrew 6 bolts from the STATOR.
- ③ Remove the BODY FRAME.
(Only 1400 rpm models)

* Note : Hook of connector (1) is on the backside

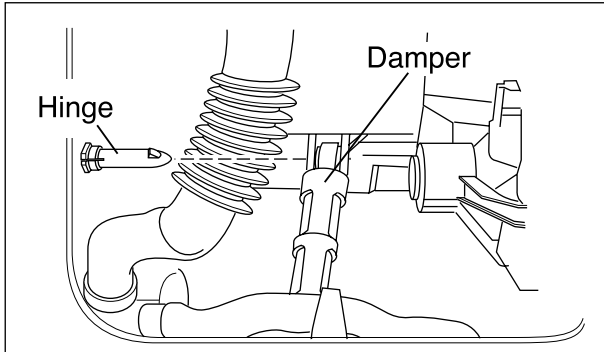

(FRICTION DAMPER ASSEMBLY)

- ① Pull out the HINGE, pressing its snap.
- ② Do not use the pulled out HINGE again
It may be taken off during operation.

■ Clean the drain pump filter

1. Open the lower cover cap (①) by using a coin. Turn the drain plug (②) to pull out the hose.

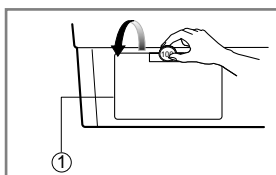

2. Unplug the drain plug (②), allowing the water to flow out. At this time use a vessel to prevent water flowing on to the floor. When water does not flow any more, turn the pump filter (③) open to the left.

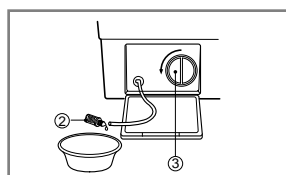

3. Remove any foreign material from the pump filter (③). After cleaning, turn the pump filter (③) clockwise and insert the drain plug (②) to the original place. close the lower cover cap.

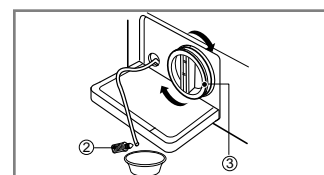

DRAIN PUMP ASSEMBLY

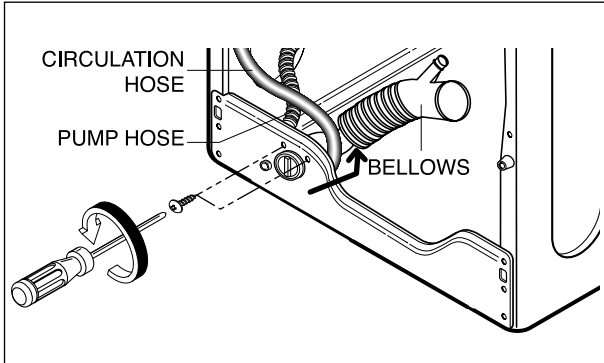

- ① Remove PUMP and CIRCULATION HOSE.
- ② Remove BELLOWS..
- ③ Disconnect the wiring.
- ④ Unscrew 2 screws
- ⑤ Remove the DRAIN PUMP ASSEMBLY.

HEATER ASSEMBLY

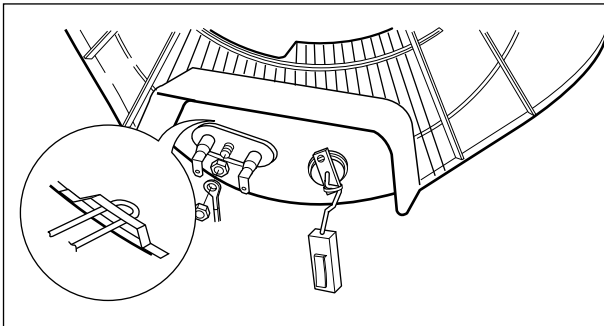

- ① Loosen the M6 heater nuts to pull out the HEATER ASSEMBLY.

CAUTION

When mounting the HEATER ASSEMBLY be sure to insert the HEATER ASSEMBLY into the heater clip on the bottom of the tub.

THERMISTOR

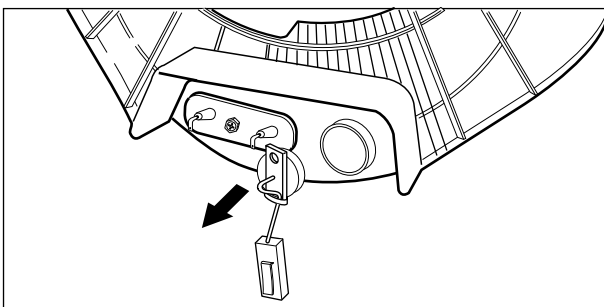

- ① Pull it out by holding the THERMISTOR bracket.
 - * If it is pulled by the wire, it may be broken.
- ② When mounting the THERMISTOR again, make sure that it is got back tight to the bushing.

SWITCH ASSEMBLY, DOOR LOCK

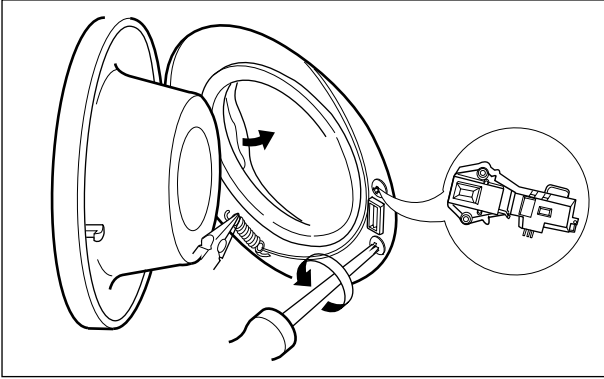

- ① Take apart the CLAMP ASSEMBLY (cabinet) and release the GASKET.
- ② Unscrew 2 screws holding the DOOR SWITCH ASSEMBLY.
- ③ Disconnect the door lock from the wiring connector.

WHEN FOREIGN MATERIAL IS STUCK BETWEEN DRUM AND TUB

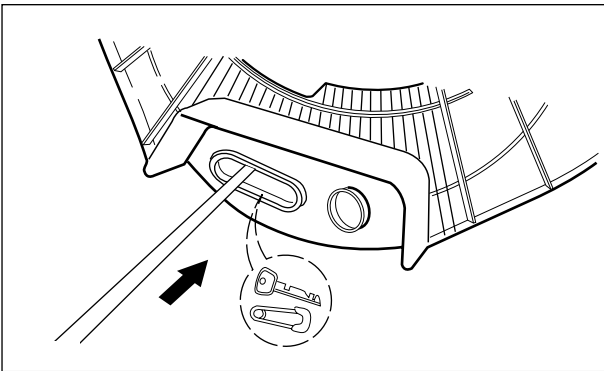

- ① Remove the HEATER ASSEMBLY.
- ② Remove the foreign material (wire, coin and others) by inserting a long bar through the hole.

10. EXPLODED VIEW AND PART LIST

10-1. THE PART LIST OF CABINET ASSEMBLY

○ : Service Part

○ : Non-Service Part

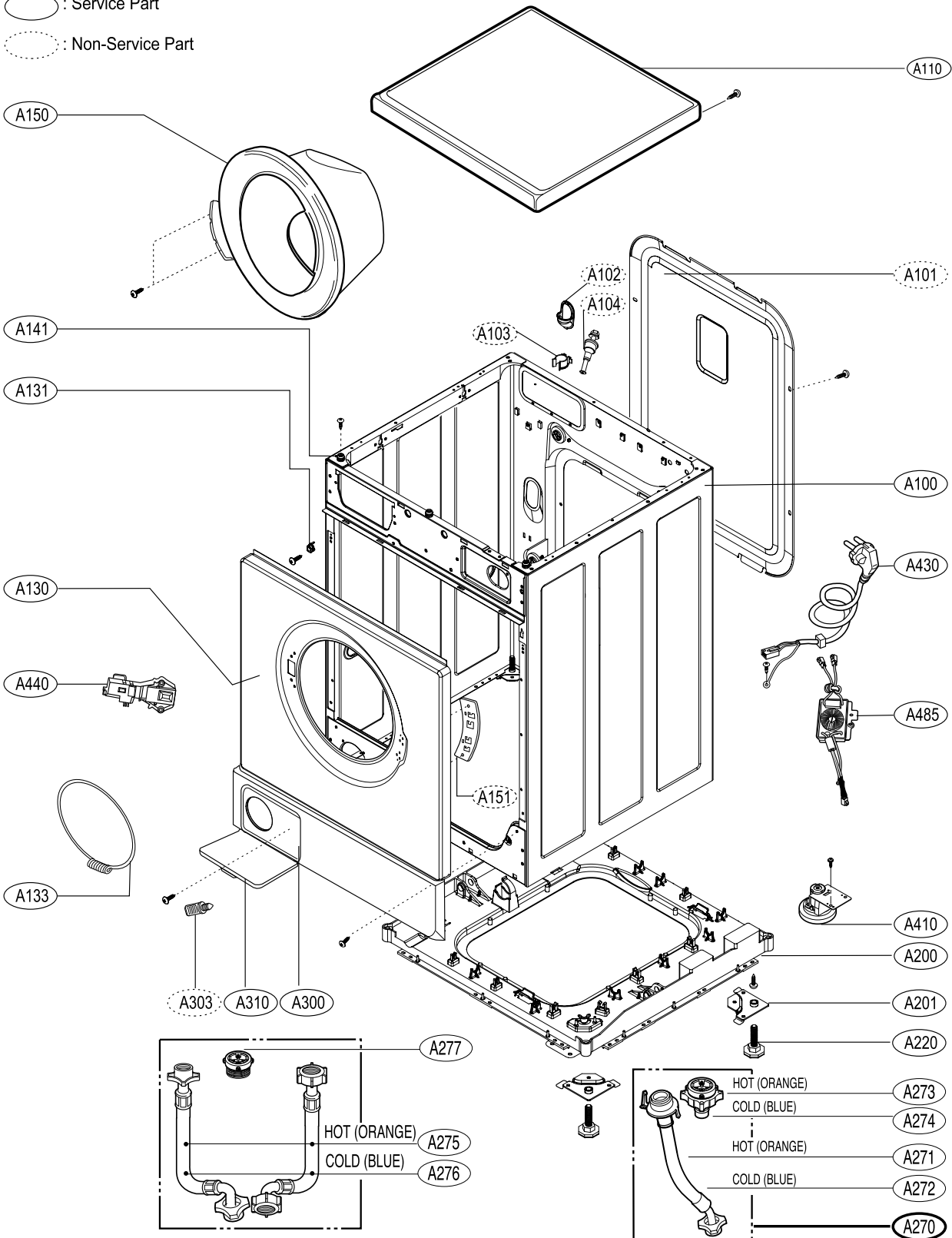

10-2 THE EXPLODED VIEW OF CONTROL PANEL & DISPENSER ASSEMBLY

○ : Service Part
 ○ : Non-Service Part

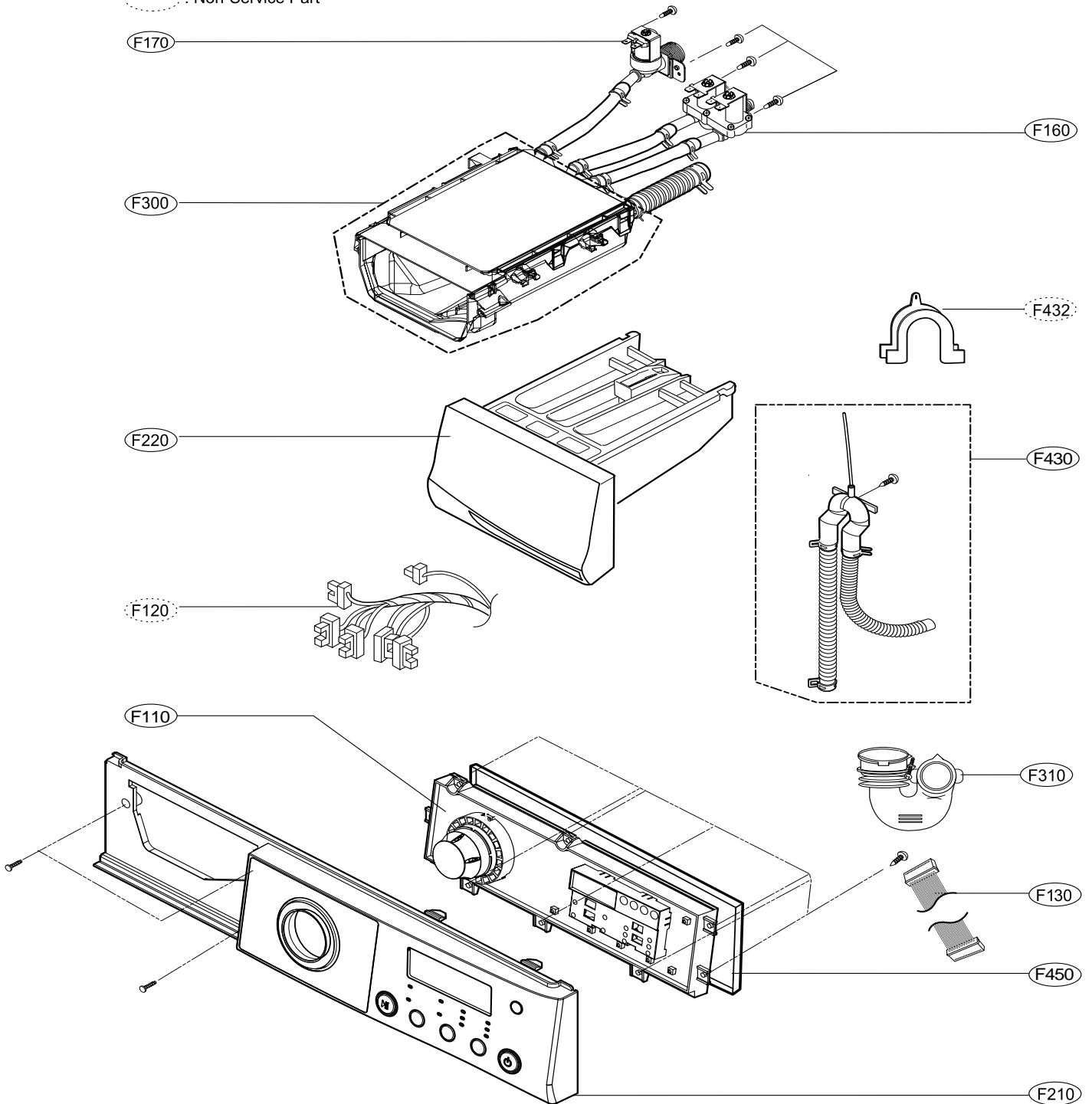

10-3 THE EXPLODED VIEW OF DRUM & TUB ASSEMBLY

○ : Service Part
 ○ : Non-Service Part

