

MDS-EX77

SERVICE MANUAL

AEP Model
UK Model
E Model



MDS-EX77 is the mini disc deck section in DHC-MD77/EX77MD.

U.S and foreign patents licensed from Dolby Laboratories Licensing Corporation.

Model Name Using Similar Mechanism	MDS-S37
MD Mechanism Type	MDM-3A
Optical Pick-up Name	KMS-260A/J1N

SPECIFICATIONS

System	MiniDisc digital audio system
Laser	Semiconductor laser ($\lambda = 780 \text{ nm}$) Emission duration: continuous
Laser output	Max. $44.6 \mu\text{W}^*$ * This output is the value measured at a distance of 200 mm from the objective lens surface on the Optical Pick-up Block with 7 mm aperture.
Recording time	74 minutes max. (using MDW-74)
Sampling frequency	44.1 kHz
Frequency response	5 Hz to 20 kHz
MD OPTICAL DIGITAL IN (CD PLAYER/VIDEO 2)	(Square optical connector jacks, rear panel)
Dimensions (w/h/d) incl. projecting parts and controls:	Approx. 280 x 90 x 288 mm
Mass	Approx. 2.3 kg

Design and specifications are subject to change without notice.

MINI DISC DECK



SONY®

TABLE OF CONTENTS

1. SERVICING NOTES	
1-1. Power Supply During Servicing	4
1-2. Fluorescent Indicator Tube/Buttons/ Jog and LEDs Check Mode	4
1-3. Selection of Input Signal	4
1-4. Retry Cause Display Mode at Record	5
2. GENERAL	7
3. DISASSEMBLY	19
4. TEST MODE	
4-1. Precautions for Use of Test Mode	24
4-2. Setting the Test Mode	24
4-3. Releasing the Test Mode	24
4-4. Basic Operations of the Test Mode	24
4-5. Selecting the Test Mode	24
4-6. Operating the Continuous Playback Mode	25
4-7. Operating the Continuous Recording Mode	25
4-8. EEP Mode	26
4-9. Functions of Other Buttons	26
4-10. Test Mode Displays	26
4-11. Meanings of Other Displays	26
5. ELECTRICAL ADJUSTMENTS	
5-1. Precautions for Checking Laser Diode Emission	27
5-2. Precautions for Use of Optical Pick-up (KMS-260A) ...	27
5-3. Precautions for Adjustments	27
5-4. Creating MO Continuously Recorded Disc	27
5-5. Temperature Compensation Offset Adjustment	28
5-6. Laser Power Adjustment	28
5-7. Traverse (E-F Balance) Adjustment	29
5-8. Focus Bias Adjustment	30
5-9. Error Rate Check	30
5-10. Focus Bias Check	30
5-11. Adjusting Points and Connecting Points	31
6. DIAGRAMS	
6-1. Block Diagram (1/2)	33
6-2. Block Diagram (2/2)	35
6-3. Printed Wiring Boards	
– MD MECHANISM DECK Section –	38
6-4. Schematic Diagram	
– MD MECHANISM DECK Section –	41
6-5. Schematic Diagram	
– MAIN/DISPLAY Section –	46
6-6. Printed Wiring Boards	
– MAIN/DISPLAY Section –	51
6-7. IC Pin Function Description	59
7. EXPLODED VIEWS	68
8. ELECTRICAL PARTS LIST	71

SAFETY-RELATED COMPONENT WARNING!!

COMPONENTS IDENTIFIED BY MARK \triangle OR DOTTED LINE WITH MARK \triangle ON THE SCHEMATIC DIAGRAMS AND IN THE PARTS LIST ARE CRITICAL TO SAFE OPERATION. REPLACE THESE COMPONENTS WITH SONY PARTS WHOSE PART NUMBERS APPEAR AS SHOWN IN THIS MANUAL OR IN SUPPLEMENTS PUBLISHED BY SONY.

NOTES ON HANDLING THE OPTICAL PICK-UP BLOCK OR BASE UNIT

The laser diode in the optical pick-up block may suffer electrostatic break-down because of the potential difference generated by the charged electrostatic load, etc. on clothing and the human body.

During repair, pay attention to electrostatic break-down and also use the procedure in the printed matter which is included in the repair parts.

The flexible board is easily damaged and should be handled with care.

NOTES ON LASER DIODE EMISSION CHECK

The laser beam on this model is concentrated so as to be focused on the disc reflective surface by the objective lens in the optical pick-up block. Therefore, when checking the laser diode emission, observe from more than 30 cm away from the objective lens.

Notes on chip component replacement

- Never reuse a disconnected chip component.
- Notice that the minus side of a tantalum capacitor may be damaged by heat.

Flexible Circuit Board Repairing

- Keep the temperature of the soldering iron around 270 °C during repairing.
- Do not touch the soldering iron on the same conductor of the circuit board (within 3 times).
- Be careful not to apply force on the conductor when soldering or unsoldering.

CAUTION

Use of controls or adjustments or performance of procedures other than those specified herein may result in hazardous radiation exposure.

This appliance is classified as a CLASS 1 LASER product. The CLASS 1 LASER PRODUCT MARKING is located on the rear exterior.

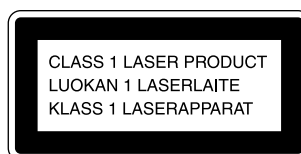

Laser component in this product is capable of emitting radiation exceeding the limit for Class 1.

The following caution label is located inside the unit.

CAUTION	;	INVISIBLE LASER RADIATION WHEN OPEN. AVOID EXPOSURE TO BEAM.
ADVARSEL	;	USYNLIG LASERSTRÅLING VED ÅBNING NÅR SIKKERHEDSAFBRYDERE ER UDE AF FUNKTION. UNNGÅ UDSÆTTELSE FOR STRÅLING.
VARO!	;	AVATTAESSA JA SUOJALUKITUS OHITETTAESSA OLET ALTIINNA LASERSÄTELYLLE.
VARNING	;	LASERSTRÅLING NÅR DENNA DEL ÅRÅPPN D OCH SPÄRREN ÄR URÖPPPLAD.
ADVARSEL	;	USYNLIG LASERSTRÅLING NÅR DEKSEL ÅPNES UNNGÅ EKSPONERING FOR STRÅLEN.

CAUTION

Danger of explosion if battery is incorrectly replaced.
Replace only with the same or equivalent type recommended by the manufacturer.
Discard used batteries according to the manufacturer's instructions.

ADVARSEL!

Lithiumbatteri-Eksplosionsfare ved fejlagtig håndtering.
Udskiftning må kun ske med batteri
af samme fabrikat og type.
Levér det brugte batteri tilbage til leverandøren.

ADVARSEL

Eksplosjonsfare ved feilaktig skifte av batteri.
Benytt samme batteritype eller en tilsvarende type
anbefalt av apparatfabrikanten.
Brukte batterier kasseres i henhold til fabrikantens
instruksjoner.

WARNING

Explosionsfara vid felaktigt batteribyte.
Använd samma batterityp eller en likvärdig typ som
rekommenderas av apparattillverkaren.
Kassera använt batteri enligt gällande föreskrifter.

VAROITUS

Paristo voi räjähtää, jos se on virheellisesti asennettu.
Vaihda paristo ainoastaan laitevalmistajan suosittelemaan tyyppiin.
Hävitä käytetty paristo valmistajan ohjeiden mukaisesti.

SECTION 1 SERVICING NOTES

1-1. POWER SUPPLY DURING SERVICING

This set has no power supply in it, and it does not operate individually. Therefore, connect to the pre/main amplifier system (TA-EX77) for the DHC-MD77 or DHC-EX77MD in servicing. If TA-EX77 is not available, use the power feed jig (PFJ-1) and jig (J-2501-078-A). Using the jig, press the power switch (S408) on the MAIN board in this set to turn on the power.

Connection:

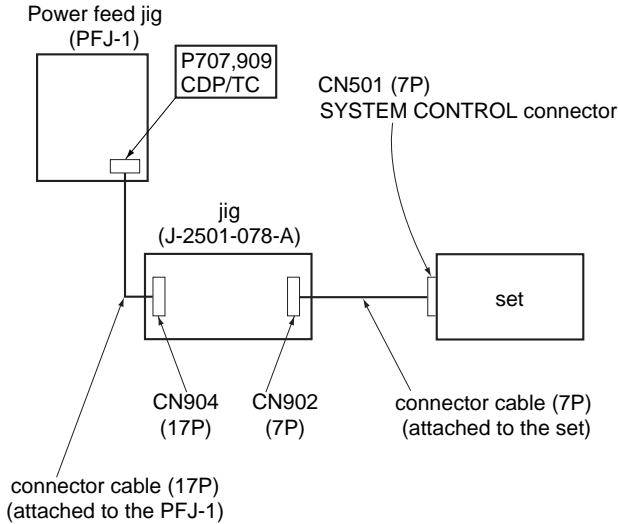

Parts Location:

MAIN board (Component Side)

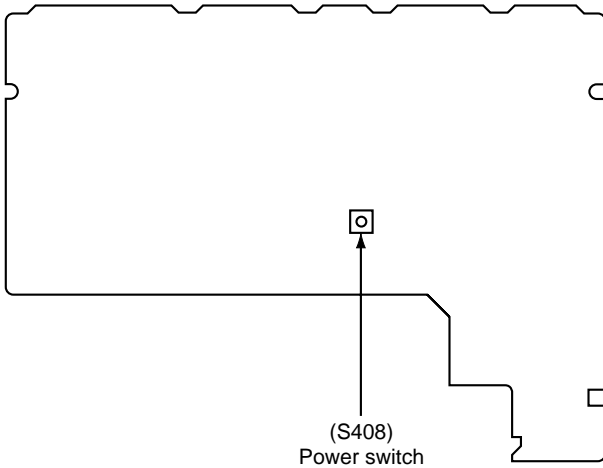

1-2. FLUORESCENT INDICATOR TUBE/BUTTONS/ JOG&LEDs CHECK MODE

1. While pressing the **CD SYNC** + **CONTINUE** buttons simultaneously, insert the power cord of TA-EX77 (pre/main amplifier) into the power outlet, then release the buttons. (Thus, the check mode is activated.)
2. When buttons are released, "Key Check" is displayed for a moment, then fluorescent indicator tubes are all turned on. (LED for ANALOG IN indication is also turned on.)
3. As the buttons other than **CD SYNC** are pressed, fluorescent indicator tubes, one block each, are turned off, and all tubes are off when operation of all buttons (except **CD SYNC** button) is finished. (ANALOG IN LED is turned off when **REPEAT** button is pressed.)
4. Press the **CD SYNC** button with fluorescent indicator tube in all off status, "Key TEST OK!" is displayed for a moment, then "JOG&LEDCheck" is displayed. (At this time, if **REPEAT** button is pressed, "STANDBY" is displayed and blinking, implying that normal operation is ready.)
5. With "JOG&LEDCheck" displayed, turning the **SELECTOR** knob, and all LEDs simultaneously turn on and off repeatedly. (If **REPEAT** button is pressed, normal operation is ready.)
6. With "JOG&LEDCheck" displayed, press the **CD SYNC** button, and "SegmentCheck" is displayed for a moment, then segment display is made. (If **REPEAT** button is pressed, normal operation is ready.)
7. Press the **CD SYNC** button, and "end" is displayed. Then, press the **REPEAT** button to finish the check mode.

1-3. SELECTION OF INPUT SIGNAL

With the power turned on, turning the **SELECTOR** knob while pressing the **REPEAT** button to select either of the following:

- Analog in
- Digital 1 in
- Digital 2 in

1-4. RETRY CAUSE DISPLAY MODE AT RECORD

Outline:

- In this mode, a cause of retry at recording can be displayed. Thus, it will help find out a faulty location of the set.
- The contents displayed are data quantity stored in D-RAM, retry count, and retry cause. There are displayed with hexadecimal numbers.
- From the data quantity in D-RAM, whether data writing, reading, storing, and ejection are executed smoothly can be confirmed. If data writing failed, data quantity will be extremely small.

Operating Method:

1. With the power turned on, load a disc (use a disc for recording of which contents may be erased).
2. Press the **[EDIT/NO]** button, and “ALL Erase?” is displayed.
3. Press the **[ENTER/YES]** button, and a message changes to “ALL Erase??” and numbers in music calendar blink.
4. Press the **[ENTER/YES]** button, and “Complete” is displayed.
5. When “Complete” appears, immediately keep pressing the **[■]** button for about 10 seconds.
6. When “TOC” on display disappears, release the **[■]** button.
7. Press the **[●REC]** button to start recording.
8. Press the **[DISPLAY/CHARACTER]** button, and the display will change as follows:

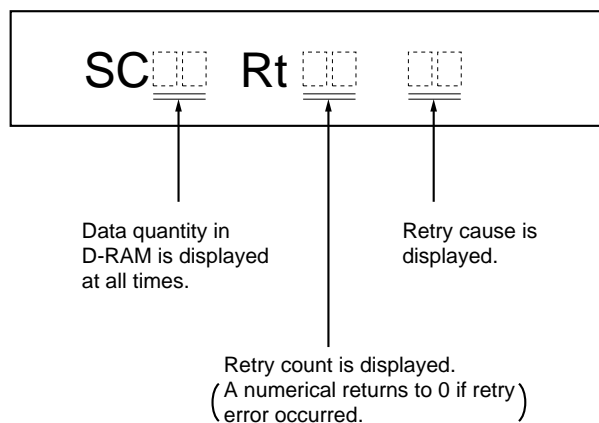

Note: These three kinds of displays are all made with hexadecimal numbers.

9. Though Rt value increments each time retry is made, if an error occurred, “Retry Error” is displayed and retry count returns to 0.
10. To exit from this mode, turn off the TA-EX77 (pre/main amplifier) and after “TOC” display disappeared, disconnect the power cord of TA-EX77 from the power outlet.
Using the jig, press the power switch (S408) on the MAIN board in this set to turn off the power.

Table 1-1. Description of Retry Cause Display

Hexa- decimal	Upper Bit				Lower Bit				Hexa- decimal	Name of Retry Cause	Description
	8	4	2	1	8	4	2	1			
Bit	b7	b6	b5	b4	b3	b2	b1	b0			
Decimal	0	0	0	0	0	0	0	0	00	spindle slow	When spindle speed slow was detected
	0	0	0	0	0	0	0	1	01	shock *1	When shock over 3.5 was detected
	0	0	0	0	0	0	1	0	02	ader 5	When ADER was counted more than 5 times successively
	0	0	0	0	0	1	0	0	04	address error	ADIP addresses are not serial
	0	0	0	0	1	0	0	0	08	(Not used)	Not used
	0	0	0	1	0	0	0	0	10	focus	Focusing failed
	0	0	1	0	0	0	0	0	20	IV-R	ABCD signal level exceeded the specified range
	0	1	0	0	0	0	0	0	40	CLV unlock	CLV is unlocked (CLV is out of range)
	1	0	0	0	0	0	0	0	80	cannot access	Access failed

*1 Some may not be used depending on the microcomputer version.

How to Use Table 1-1.:

Use table 1-1. by converting hexadecimal number of each digit into decimal number (see table 1-2). If an error occurred by two or more causes, respective numbers are added.

Table 1-2. Hexadecimal number - Decimal number Conversion

Hexadecimal	Decimal	Hexadecimal	Decimal
0	0000	8	1000
1	0001	9	1001
2	0010	A	1010
3	0011	B	1011
4	0100	C	1100
5	0101	D	1101
6	0110	E	1110
7	0111	F	1111

Example 1: If “42” is displayed

Higher bit: 4=0100 → b6

Lower bit: 2=0010 → b1

This case shows that retry was made due to combined causes of “CLV unlock” and “ADIP error”.

Example 2: If “A2” is displayed

Higher bit: A=1010 → b7 + b5

Lower bit: 2=0010 → b1

This case shows that retry was made due to combined causes of “cannot access”, “IV-R”, and “ADIP error”.

The MD Deck (DHC-MD771EX/77MD only)

Using the MD display

You can check the remaining time of the current track or that of the MD.

Checking the remaining time of a track

DISPLAY/CHARACTER

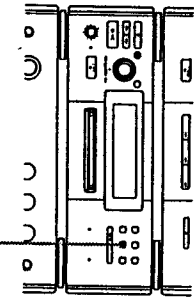

Press DISPLAY/CHARACTER during play.

Each time you press the button, the display changes as follows:

- ▶ Playing time and the track number on the current track
- ▶ Remaining time and the track number on the current track
- ▶ Track title on the current track*

* "No Name" appears if no track title is stored.

Checking the remaining time of an MD

Press DISPLAY/CHARACTER in stop mode.

Each time you press the button, the display changes as follows:

- ▶ Total playing time and the track numbers on the MD
- ▶ Remaining recordable time on the MD (only for a recordable MD)
- ▶ Disc title on the MD

Tips

- Tracks numbered 1 to 25 appear in the Music Calendar Display. If the track numbers exceed 25, ▶ appears to the right of number 25.
- The music calendar showing the track numbers appears within a grid if the MD is a premastered disc, or without a grid if the MD is a recordable disc.

Note

The correct remaining time may not be displayed due to the MD's system limitations.

Playing the MD tracks repeatedly

— Repeat Play

This function lets you repeat a single track or all the tracks on an MD in normal Play, Shuffle Play and Program Play.

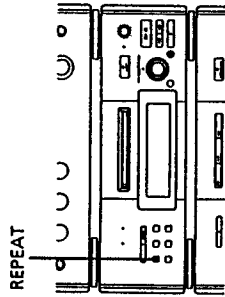

Press REPEAT during play until "REPEAT" (for all the tracks) or "REPEAT 1*" (for a single track) appears.

Repeat Play starts.

- You cannot repeat a single track during Shuffle Play and Program Play.

To cancel Repeat Play
Press REPEAT repeatedly until "REPEAT" or "REPEAT 1*" disappears.

Playing the MD tracks in random order

— Shuffle Play

You can play the tracks in random order.

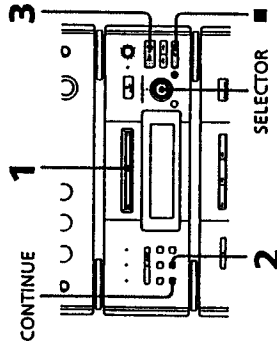

1 Insert an MD.

2 Press SHUFFLE. "SHUFFLE" appears.

3 Press ◁ 00 (or ▷ on the remote). The sound source automatically switches to the MD deck. "EJ" appears, then all the tracks play in random order.

To cancel Shuffle Play
Press ■, then CONTINUE.

Tip

To skip the tracks, turn SELECTOR clockwise (or press ▶ on the remote).

Note

You cannot start Shuffle Play during playback. Press ■, then SHUFFLE.

Programming the MD tracks

— Program Play

You can make a program of up to 25 tracks in the order you want them to be played.

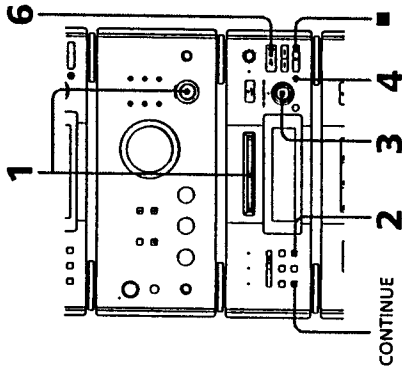

1 Turn FUNCTION until the MD indicator lights up, then insert an MD.

2 Press PROGRAM. "PROGRAM" appears.

3 Turn SELECTOR until the desired track number appears.

4 Press ENTER/YES.

The track is programmed. The last programmed track appears, followed by the total playing time.

The last programmed track

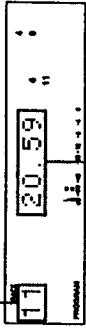

Total playing time

5 To program additional tracks, repeat steps 3 and 4.

6 Press \blacktriangle (or \blacktriangleright on the remote). All the tracks play in the order you selected.

To

Cancel Program Press \blacksquare , then CONTINUE.

Play

Add a track to the program (in stop mode) "Programming the MD tracks."

Clear the entire program Press \blacksquare in stop mode.

Tip

The program you made remains after the Program Play has finished. To play the same program again, press \blacktriangle .

Note

You cannot start Program Play during playback. Press \blacksquare , then PROGRAM.

Before you start recording

MDs (MiniDisc) let you digitally record and play back music with high quality sound that compares with the sound of CDs. Another feature of MDs is track marking. The track marking feature lets you quickly locate a specific point or easily edit the recorded tracks. However, depending on the source you record, the recording method varies. Also, the way the track numbers are recorded differs depending on the source.

When the source you record from is:

- **This system's CD player**
 - The digital signal from the CD is recorded as it is (digital recording).
 - Track numbers are automatically marked as on the original CD.

• **Other digital components**

- (e.g., a DAT deck)
 - When you set MODE SELECTOR on the rear panel of the amplifier to DIGITAL REC, the digital signal from the connected component is recorded as it is (digital recording).
 - When you set MODE SELECTOR on the rear panel of the amplifier to ANALOG REC, the digital signal is converted to an analog signal once, then re-converted to a digital signal and recorded (analog recording).
 - A track number is marked at the beginning of a recording, but when you turn on the Level Sync function (see page 43), track numbers are automatically marked in sync with the level of the input signal.

* For details on limitations of digital recording, see page 68.

• **This system's tuner, other analog components or a microphone**

- (e.g., a tape deck)
 - The analog signal is converted to a digital signal and recorded (analog recording).
 - A track number is marked at the beginning of a recording, but when you turn on the Level Sync function (see page 43), track numbers are automatically marked in sync with the level of the input signal.

• Track numbers may not be marked correctly if the sound source is noisy.

Note on the track number of an MD

On an MD, the track number (track sequence), track start and end point information, etc., are recorded in the TOC* area independent of the sound information. You can edit recorded tracks quickly by modifying the TOC information.

* TOC: Table Of Contents

Recording on an MD manually

The system automatically locates the last recorded portion and starts recording from that point. Also, you can record over the previous recording just as you would using a tape deck.

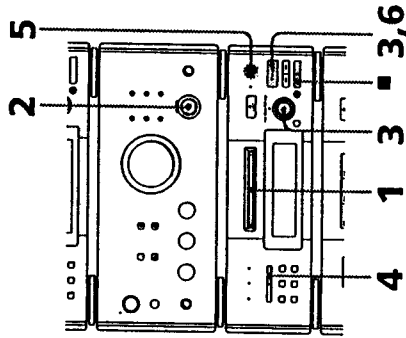

- 1 Insert a recordable MD.
- 2 Turn FUNCTION and select the source (e.g., CD) you want to record.

- 3 Select the point at which you want to start recording. To record on a blank MD or record from the last recorded portion, skip this step. To record over:
 - From a specific position of the track Play the MD and press \blacktriangleright 00 at the desired point. The system changes to recording pause.
 - From the beginning of the track Turn SELECTOR until the desired track number appears. If you want to record over all the tracks, select the track number 1 here.

- 4 Press ● REC. The deck stands by for recording. To mark track numbers, see "Marking track numbers" on page 43. When recording from this system's CD, the track numbers are automatically marked.

- 5 Turn REC LEVEL to adjust the analog recording level. When you record the analog input signal (when the ANALOG IN indicator lights up), adjust the recording level. For details, see "Adjusting the recording level" on page 37.

- 6 Press \blacktriangleright 00 on the MD deck (or ■ on the remote). Recording starts.
- 7 Start playing the source to be recorded.

Adjusting the recording level

When the ANALOG IN indicator lights up (analog recording), adjust the recording level before starting recording. You cannot adjust the recording level during digital recording.

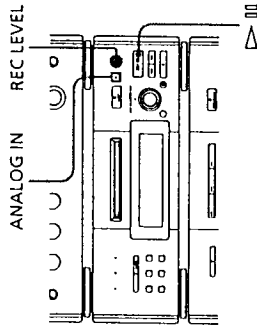

- 1 Do steps 1 to 4 in "Recording on an MD manually" on page 36.
- 2 Play the portion of the source you want to record with the strongest signal level.
- 3 Press REC LEVEL to extend the control.

To stop recording
Press ■ on the MD deck.

if "OVER" appears in the level meter
A high-level signal was input during analog recording. Reduce the recording level using REC LEVEL (see this page), then re-record.

While "TOC" lights up or is flashing
Do not move the deck or pull out the power cord to ensure the complete recording. The deck is currently updating the Table Of Contents (TOC).

While "TRACK" is flashing
The deck is recording over an existing recording. "TRACK" lights continuously while recording on a blank portion of the MD.

Note

If you pause recording during CD recording, a track number is recorded at that point. Also, note that the tracks are recorded as a single track with a single track number when:

- a single track of the same CD is recorded repeatedly.
- two or more tracks with the same track number from different CDs are recorded continuously.

Adjusting the recording level (continued)

- Turn REC LEVEL to adjust the recording level. While monitoring the sound, adjust the level so that "OVER" does not appear in the level meter.

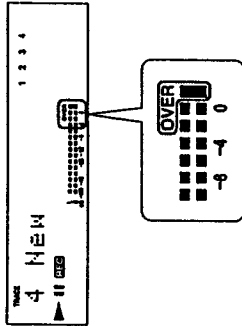

- Stop playing the sound source.
- To start recording, press **DISC 1-3** on the MD deck (or **RECORD** on the remote).
- Start playing the source to be recorded.
- Press REC LEVEL again when recording is finished.

Recording the favorite CD tracks on an MD

You can select your favorite CD tracks with the Program Play feature, then record the program on an MD using the CD Synchro Recording feature.

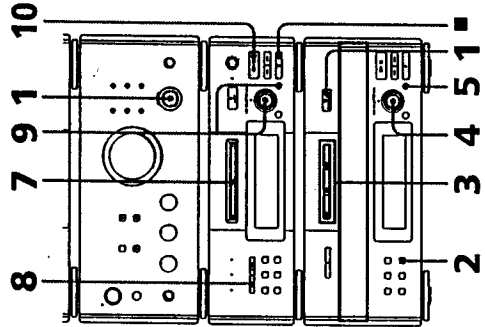

Selecting the tracks

- Turn FUNCTION until the CD indicator lights up, then place a CD (CDs) on the disc tray.
- Press PROGRAM on the CD player. "PROGRAM" appears.

- Press one of the DISC 1 - 3 buttons to select a CD.

- Turn SELECTOR on the CD player until the desired track number appears.

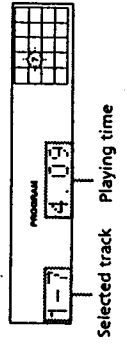

- Press ENTER. The track is programmed. The last programmed track appears, followed by the total playing time.
- To program additional tracks, repeat steps 3 to 5. Skip step 3 if you select a track from the same disc.

Recording on an MD

- Insert a recordable MD. To insert an MD, see page 19.
- Press CD SYNC.
- Turn SELECTOR on the MD deck until "NORMAL ?" appears, then press ENTER/YES. The MD deck stands by for recording and the CD is in pause for playback.

- Press **STOP** on the MD deck (or **STOP** on the remote). Recording starts from the last recorded portion of the MD. The CD player stops and the MD deck pauses automatically when the recording is completed. If there is no remaining recording time on the MD, the MD deck stops.

To stop recording
Press **STOP** on the MD deck.

Recording only the first track on each CD — Hit Parade

This feature is useful when you record single CDs in succession.

Recording from three CDs

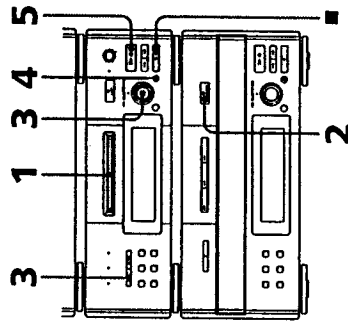

- 1 Insert a recordable MD.
- 2 Place CDs on the disc tray.
- 3 Press CD SYNC, then turn SELECTOR on the MD deck until "HIT PARADE ?" appears.
- 4 Press ENTER/YES.
- 5 Press \triangleright on the MD deck (or \square on the remote). Recording starts from the CD loaded on disc tray number 1 (DISC 1).

Recording from four or more CDs

You can exchange CDs without stopping or pausing the recording.

3,4

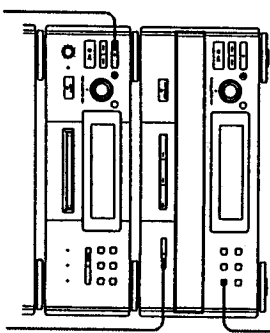

2

- 1 Start recording according to the procedure described in "Recording from three CDs."
- 2 Press REPEAT on the CD player during recording until "REPEAT" appears.
- 3 Press EX-CHANGE while recording the third track. The disc tray opens.
- 4 Exchange CDs, then press EX-CHANGE again. The disc tray closes.
- 5 To record additional tracks from other CDs, repeat steps 3 and 4 while recording the last track.

To stop recording
Press \blacksquare on the MD deck.

Starting recording with 2 seconds of prestored audio data

— Time Machine Recording

When recording from an FM or satellite broadcast, the first few seconds of material are often lost due to the time it takes you to ascertain the contents and press the record button. To prevent the loss of this material, the Time Machine Recording feature constantly stores 2 seconds of the most recent audio data in a buffer memory. When you start recording the sound source, the recording actually starts with the 2 seconds of audio data stored in the buffer memory in advance, as shown in the illustration below:

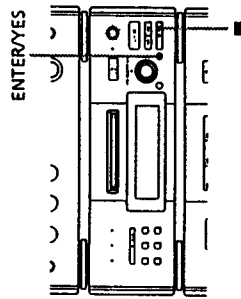
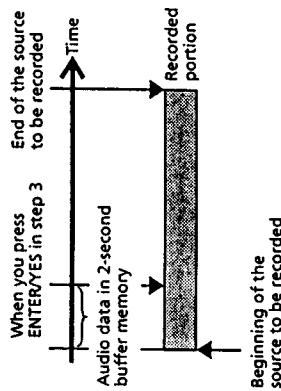

- 1 Do steps 1 to 5 in "Recording on an MD manually" on page 36. The MD deck stands by for recording.

- 2 Start playing the source to be recorded. The most recent 2 seconds of audio data is stored in the buffer memory.

- 3 Press ENTER/YES at the point you want to start recording.

Recording of the source starts with the 2 seconds of audio data stored in the buffer memory.

To stop Time Machine Recording

Press \blacksquare on the MD deck.

Note

The MD deck starts storing audio data when the deck is in recording pause and you start playing the source. With less than 2 seconds of playing of the source and audio data stored in the buffer memory, Time Machine Recording starts with less than 2 seconds of audio data.

Making a space between tracks 3 seconds long

The Smart Space and Auto Cut functions let you make a blank space between tracks three seconds long, automatically while making a digital recording.

Smart Space

There has been an extended silence of 4 to 30 seconds while digital recording.

The MD deck replaces the silence with a blank of about 3 seconds and continues recording.

Note that the tracks before and after this three-second space may be recorded as a single track with a single track number.

Auto Cut

There has been no sound input for 30 seconds while digital recording.

The MD deck replaces the silence of 30 seconds with a blank of about 3 seconds and changes to recording pause.

The Smart Space and Auto Cut functions are both turned on at the same time. You cannot use one of these functions without the other.

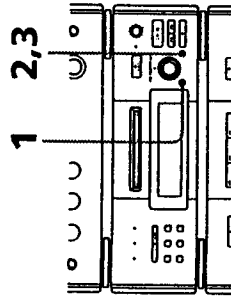

Marking track numbers

When you record from this system's CD (digital recording), the track numbers are automatically marked. In addition, you can mark track numbers:

- At any point while recording.
- Automatically while analog recording.

Marking track numbers at a specific point while recording

You can mark track numbers at any time while recording, regardless of the type of sound source.

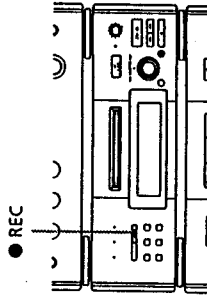

Press ● REC while recording at the point you want to add a track mark. A track number is marked at that point.

Marking track numbers automatically while analog recording

Track numbers are automatically marked when the input signal continues to be under a certain level for more than two seconds and then returns to the previous level.

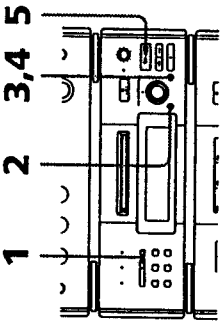

- 1 Press ● REC.
The MD deck stands by for recording.
- 2 Press EDIT/NO repeatedly until "LevelSync ?" appears.
- 3 Press ENTER/YES.
"LevelSyncON?" appears.
- 4 Press ENTER/YES again.
"LEVEL-SYNC" lights up.
- 5 Press ▷ 00 (or II on the remote).
Recording starts.

To cancel the track marking

- 1 Press EDIT/NO repeatedly until "LevelSync ?" appears.
 - 2 Press ENTER/YES.
"LevelSyncON?" appears.
 - 3 Press EDIT/NO.
"LEVEL-SYNC" disappears.
- In this way, a track number is marked only at the beginning.

Note

You cannot mark track numbers automatically if the sound source to be recorded is noisy (e.g., tapes or radio programs).

- 1 During recording pause, press EDIT/NO repeatedly until "S. Space ?" appears.

- 2 Press ENTER/YES within three seconds.
"S. Space ON?" appears.

- 3 Press ENTER/YES again.
"S. Space ON" appears.
When "Smart Space" appears during recording, the Smart Space function is activated. When "Auto Cut" appears, the Auto Cut function is activated.

To turn off the Smart Space and Auto Cut functions

- 1 During recording pause, press EDIT/NO repeatedly until "S. Space ?" appears.
- 2 Press ENTER/YES.
- 3 Press EDIT/NO so that "S. Space OFF" appears.

Notes

- The Smart Space and Auto Cut functions are factory set to on.
- If you turn the power off or disconnect the AC power cord, the MD deck will recall the last setting (on or off) of the Smart Space and Auto Cut functions the next time you turn the power on.

Monitoring the input signal

— Input Monitor

You can monitor the signal being input to the MD deck without recording it. This lets you adjust the recording level of analog sources.

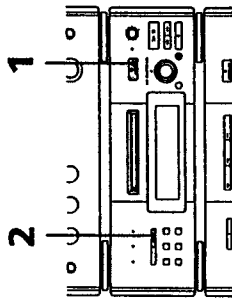

- 1 Press **EJECT** to remove the MD.
- 2 Press **REC**.
If the input signal is analog, the **ANALOG IN** indicator lights up, and "AD-DA" appears.
If the input signal is digital, "DA" appears.

Before you start editing

When you edit recorded tracks, there is no need for copying the MD.

- **To change the order of tracks**
Use the Move Function (see page 47) to change the track numbering.
- **To erase recordings**
Use the Erase Function (see page 45). This lets you erase a single track one by one or all tracks at once.
- **To locate the beginning of a specific phrase**
Use the Divide Function (see page 48) to add track numbers. This lets you find your favorite phrases quickly and play them repeatedly.
- **To create a medley by combining several phrases**
Use the Divide and Erase Functions to erase unwanted portions, then put several phrases into a single track using the Combine Function (see page 49).

By using the editing functions in this way, you can create original MD albums.

Erasing recordings

— Erase Function

The MD system lets you erase unwanted sound quickly and easily. The three options to erase recordings are:

- Erasing a single track
- Erasing all tracks
- Erasing a portion of a track

Note

When "SHUFFLE" or "PROGRAM" appears in the display, press CONTINUE so that the indication disappears.

Erasing a single track

You can erase a track simply by specifying its track number. When you erase a track, the total number of tracks on the MD decreases by one and all the tracks following the erased one are renumbered.

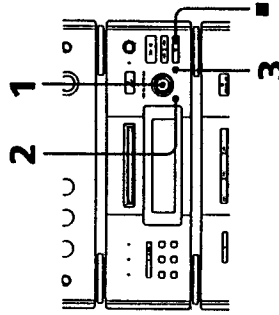
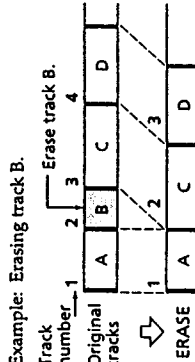

- 1 Turn SELECTOR until the track number you want appears.

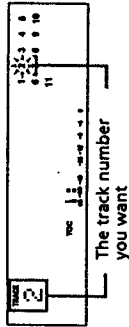

- 2 Press EDIT/NO repeatedly until the selected track number and "2 Erase ?" appear.
- 3 Press ENTER/YES.
"Complete" appears for a few seconds and the selected track and title are erased.

To cancel the Erase Function

Press **STOP** on the MD deck.

Note

"Erase!! ?" appears when the track was recorded or edited on another deck and is record protected. To erase the track, press ENTER/YES while "Erase!! ?" is displayed.

Erasing recordings (continued)

Erasing all tracks

You can erase the disc title, all recorded tracks and their titles at once.

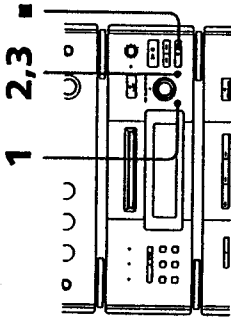

- 1 While the deck is stopped, press EDIT/NO repeatedly until "All Erase ?" appears.
- 2 Press ENTER/YES. "All Erase ??" appears. To cancel the Erase Function at this time, press ■.
- 3 Press ENTER/YES again. "Complete" appears for a few seconds and all recorded tracks and their titles are erased.

Erasing a portion of a track

By using the Divide (see page 48), Erase (see page 45), and Combine (see page 49) Functions, you can erase specific portions of a track.

Example: Erasing a portion of track A.

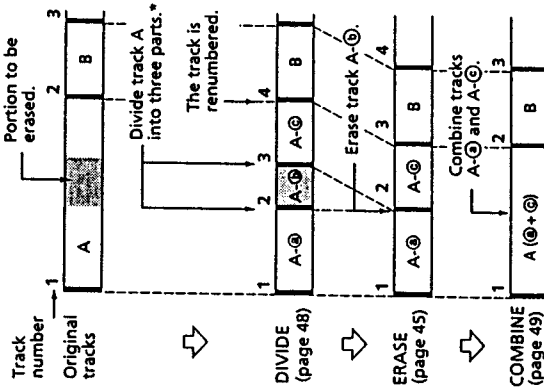

* The tracks are renumbered.

Tip
You can undo a track erasure. See "Undoing the last edit" on page 51.

Moving recorded tracks

— Move Function

By using the Move Function, you can change the order of any track on the disc. When you move tracks, the tracks are automatically renumbered.

Example: Moving track C to position 2.

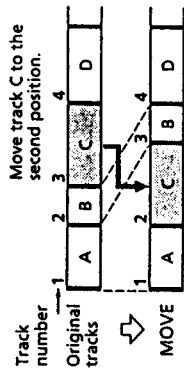

2 1,4

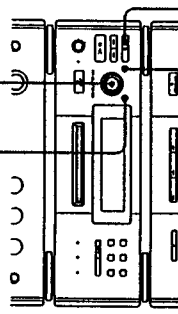

3,5

- 1 Turn SELECTOR until the track number you want to move appears.
- 2 Press EDIT/NO repeatedly until "Move ?" appears.
- 3 Press ENTER/YES.

- 4 Turn SELECTOR until the new track position appears. To cancel the Move Function at this time, press ■.



The original track number position

- 5 Press ENTER/YES. "Complete" appears for a few seconds.

Note

When "SHUFFLE" or "PROGRAM" appears in the display, press CONTINUE so that the indication disappears.

Dividing recorded tracks

— Divide Function

You can use this function to add track numbers to multiple tracks that are recorded as one track. This function also lets you mark track numbers after the recording ends. The total number of tracks increases by one and all the tracks following the divided ones are renumbered.

Example: Dividing track 2 into tracks B and C.

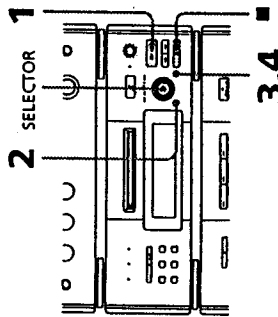
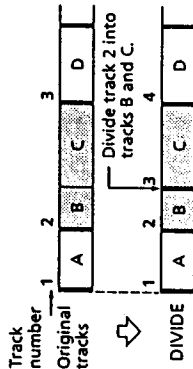

- 1 While playing the MD, press \triangleright 00 (or \blacksquare on the remote) at the point to be divided.
The MD deck pauses.
- 2 Press EDIT/NO repeatedly until the selected track number and "2 Divide ?" appear.

- 3 Press ENTER/YES. "Rehearsal" and "Position ok?" appear alternately and the portion to be divided is played repeatedly.

To shift the position to be divided:

- 1 Press EDIT/NO.
- 2 While monitoring the sound, turn SELECTOR to the starting point to be divided.

You can check the display and shift the point between -128 and +127 (± 01 is about 0.06 seconds).

To cancel the Divide Function at this time, press \blacksquare .

- 4 Press ENTER/YES again when you find the point to be divided. "Complete" appears for a few seconds and the newly created track begins playing.

Tip
You can also divide tracks while recording. Press \bullet REC at the desired point (see page 43).

Notes

- When "SHUFFLE" or "PROGRAM" appears in the display, press CONTINUE so that the indication disappears.
- The new track will have no track title even if the original track was labeled.

Combining recorded tracks

— Combine Function

This function lets you put several tracks or several independently recorded portions into a single track. The total number of tracks decrease by one and all the tracks following the combined ones are renumbered.

Example: Combining tracks B and C.

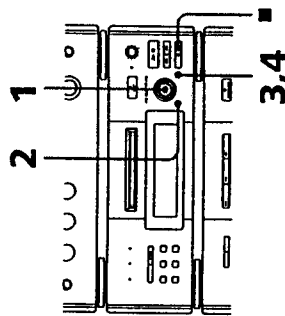
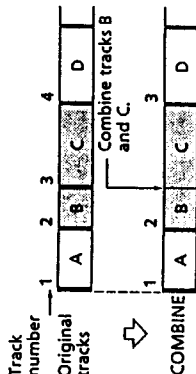

- 1 Turn SELECTOR until the second track of the two to be combined appears.
For example, to combine tracks 2 and 3, - select track 3.
- 2 Press EDIT/NO repeatedly until the selected track number and "3 Combine ?" appear.

- 3 Press ENTER/YES. "Rehearsal" and "Track ok?" appear alternately and the portion where the two tracks will join (i.e., the end of the first track and the beginning of the second track) is played repeatedly. To cancel the Combine Function at this time, press \blacksquare .

- 4 Press ENTER/YES again when you find the portion. "Complete" appears for a few seconds and the tracks are combined.

Notes

- When "SHUFFLE" or "PROGRAM" appears in the display, press CONTINUE so that the indication disappears.
- If both of the combined tracks have track titles, the title of the second track is erased.
- If "Sorry" appears, the tracks cannot be combined. This happens when you have edited the same track too many times. This is due to a technical limitation of the MD system and is not a mechanical error.

Labeling an MD

You can create titles (names) for your recorded MDs and tracks. You can use up to 1,700 characters for a disc.

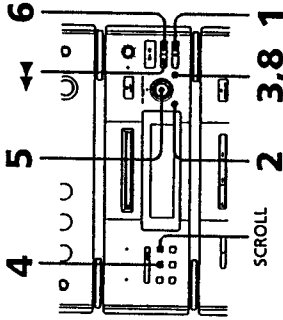

1 To label a disc, press **■** and stop playing the disc.
To label a track, turn **SELECTOR** until the desired track number appears.

2 Press **EDIT/NO** repeatedly until "Name in ?" appears.

3 Press **ENTER/YES**.
The cursor starts flashing.

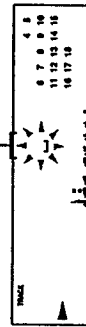

4 Press **DISPLAY/CHARACTER** repeatedly until the desired type of character appears.
Each time you press the button, the display changes as follows:

A (Upper cases) → a (Lower cases)
→ 0 (Numbers and Symbols*) → A...

*You can use the following symbols:

! " # \$ % & ' () * + , - . / : ; < = > ? @ _ `

5 Turn **SELECTOR** until the character you want appears.
The selected character flashes. To enter a blank space, press **▶▶** while the cursor is flashing.

6 Press **▶▶** to enter the character.
The cursor shifts rightward and waits for the input of the next character.

7 Repeat steps 4 to 6 to complete the entire title.
If you made a mistake, press **◀◀** or **▶▶** until the character you want to change flashes, then repeat steps 4 to 6.
To erase the character, press **EDIT/NO** while the character is flashing.

8 Press **ENTER/YES** to complete the labeling procedure.
The titles you entered appear sequentially.

To cancel labeling
Press **■** on the MD deck.

To check the titles

To check the disc titles, press **SCROLL** while the play is being stopped. To check the track titles, press **SCROLL** while in play. The titles are displayed scrolling in the display. To stop scrolling, press **SCROLL**. Press the button again to restart scrolling.

To change an existing title

Start over from step 1.

To erase all titles

1 Press **EDIT/NO** repeatedly until "Name Erase ?" appears.

2 Press **ENTER/YES**.

All the disc titles and track titles are erased. To cancel erasing, press **■** on the MD deck.

Tips

- You can label a track title while playing or recording, but you must complete the labeling before the track ends.
- You can undo a name erasion.

See "Undoing the last edit" on this page.

Undoing the last edit

— Undo Function

This function lets you cancel the last edit and restore the contents of the MD to the condition before the edit.

Note, however, that you cannot undo an edit if you do any of the following after the edit:

- Press the **● REC** or **CD SYNC** button on the MD deck.
- Update the **TOC** by turning the power off or ejecting the MD.
- Disconnect the **AC power cord**.

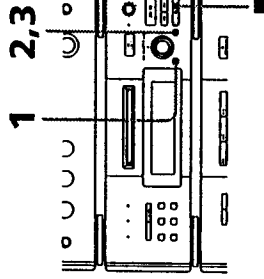

1 While the deck is stopped with no track number appearing in the display, press **EDIT/NO** repeatedly until "Undo ?" appears.
"Undo ?" does not appear if you have done no editing.

Undoing the last edit (continued)

2 Press ENTER/YES.

One of the following messages appears, depending on the last edit.

Editing done:	Message:
Erasing a single track	"Erase Undo?"
Erasing all tracks on an MD	"Erase Undo?"
Dividing a track	"Divide Undo?"
Combining tracks	"Combine Undo?"
Moving a track	"Move Undo?"
Labeling a track or an MD	
Changing an existing title	"Name Undo?"
Erasing all titles on an MD	

3 Press ENTER/YES again.

"Complete" appears for a few seconds and the contents of the MD are restored to the condition before the edit.

To cancel the Undo Function

Press EDIT/NO or ■ on the MD deck.

System limitations of MDs

The recording system in your MD deck has limitations described below. Note, however, that these limitations are due to the inherent nature of the MD recording system itself and not to mechanical causes.

"Disc Full" lights up before the MD has reached the maximum recording time (60 or 74 minutes)

When 255 tracks have been recorded on the MD, "Disc Full" lights up regardless of the total recorded time. More than 255 tracks cannot be recorded on the MD. To continue recording, erase unnecessary tracks or use another recordable MD.

"Disc Full" lights up before the maximum number of tracks (255) is reached

Fluctuations in emphasis within tracks are sometimes interpreted as track intervals, increasing the track count and causing "Disc Full" to light up.

The remaining recording time does not increase even after erasing numerous short tracks

Tracks shorter than 12 seconds long are not counted, so erasing them may not increase the recording time.

Some tracks cannot be combined with others

Track combination may become impossible when tracks are shorter than 12 seconds long.

The total recorded time and the remaining time on the MD may not reach the maximum recording time (60 or 74 minutes)

Recording is done in minimum units of 2 seconds each, no matter how short the material. The contents recorded may thus be shorter than the maximum recording capacity. Disc space may also be further reduced by scratches.

The sound may drop-out while searching the edited tracks

Tracks created through editing may exhibit sound dropout during searching because high-speed playback takes time to search for the position on the disc when the tracks are scattered on the disc.

Track numbers cannot be marked

When "LevelSync ON" (page 43) is displayed during analog recording, the track numbers may not be marked at the beginning of the track:

- if the input signal is below a certain fixed level for less than two seconds.
- if the input signal is below a certain fixed level for more than two seconds in the middle of the track.

Guide to the Serial Copy Management System

Digital audio components, such as CDs, MDs, and DATs let you copy music easily with high quality, for these digital products process music as a digital signal.

To protect the copyrighted music programs, this system uses the Serial Copy Management System that allows you to make only a single copy of a recorded digital source through digital-to-digital connections.

You can make only a first generation copy* through a digital-to-digital connection.

That is:

- 1 You can make a copy of a commercially available digital sound program (e.g., a CD and an MD), but you cannot make a second copy from the first-generation copy.
 - 2 You can make a copy of a digital signal from a digitally recorded analog sound program (e.g., an analog record and a music cassette tape) or from a digital satellite broadcast program, but you cannot make a second copy.
- * A first-generation copy means a digital recording of a digital signal made on digital audio equipment. For example, if you record from this system's CD player to this MD deck, you'd make a first-generation copy.

Notes

- This copy management system does not apply when you make a recording through analog-to-analog connections.
- This system's MD deck supports 32 kHz or 48 kHz sampling frequency of the DAT deck or digital satellite broadcast programs as well as 44.1 kHz sampling rate of the MD deck. You can make a second copy from a digital recording of the satellite broadcast program.

MD messages

(DHC-MD77/EX77MD only)

One of the following messages may appear or flash in the display during MD operation.

Auto Cut

The MD deck is pausing the recording because silence continued for 30 seconds or more during digital recording.

Blank Disc

The inserted recordable MD is brand new or all tracks on the MD have been erased.

Cannot Copy

You cannot make a digital recording (see "Guide to the Serial Copy Management System" on page 69).

Cannot EDIT

You tried to edit in Program or Shuffle Play mode.

Din Unlock

Check that the optical cable is properly connected.

Disc Error

The inserted MD is damaged or does not contain a TOC.

Disc Full

There is no time remaining on the disc (see "System Limitations of MDs" on page 68).

Impossible

You tried to combine from the first track on an MD, which is not possible.

Name Full

There is no more space to store track or disc titles.

NEW

The MD deck stands by for recording on a brand new MD or from the last recorded portion.

NO DISC

There is no MD in the deck.

No Track

The inserted MD has a disc title but no tracks.

OVER

You have reached the end of the last track during high-speed search.

Over Write

The deck stands by for recording over previous recordings.

Protected

The inserted MD is protected against erasure.

Retry

The MD deck is redoing the recording because of vibrations or disc scratches encountered during recording.

Retry Error

Due to vibration affecting the deck or scratches on the MD, several recording attempts were made but with no success.

Smart Space

The signal was input again after silence continued for 3 to 30 seconds or less during digital recording.

Sorry

You tried to combine tracks that cannot be combined.

SECTION 3 DISASSEMBLY

- This set can be disassembled in the order shown below.

CASE, FRONT PANEL
SECTION (Page 19)



MECHANISM DECK
(Page 20)



BRACKET (T), (L), (R)
(Page 20)

BD BOARD
(Page 21)

SUB CHASSIS
(Page 21)

OVER WRITE HEAD
(Page 22)

SHUTTER ASS'Y
(Page 22)

SLIDER COMPLETE
ASS'Y
(Page 23)
NOTE FOR
INSTALLATION
• SLIDER COMPLETE
ASS'Y (Page 23)

Note: Follow the disassembly procedure in the numerical order given.

CASE, FRONT PANEL SECTION

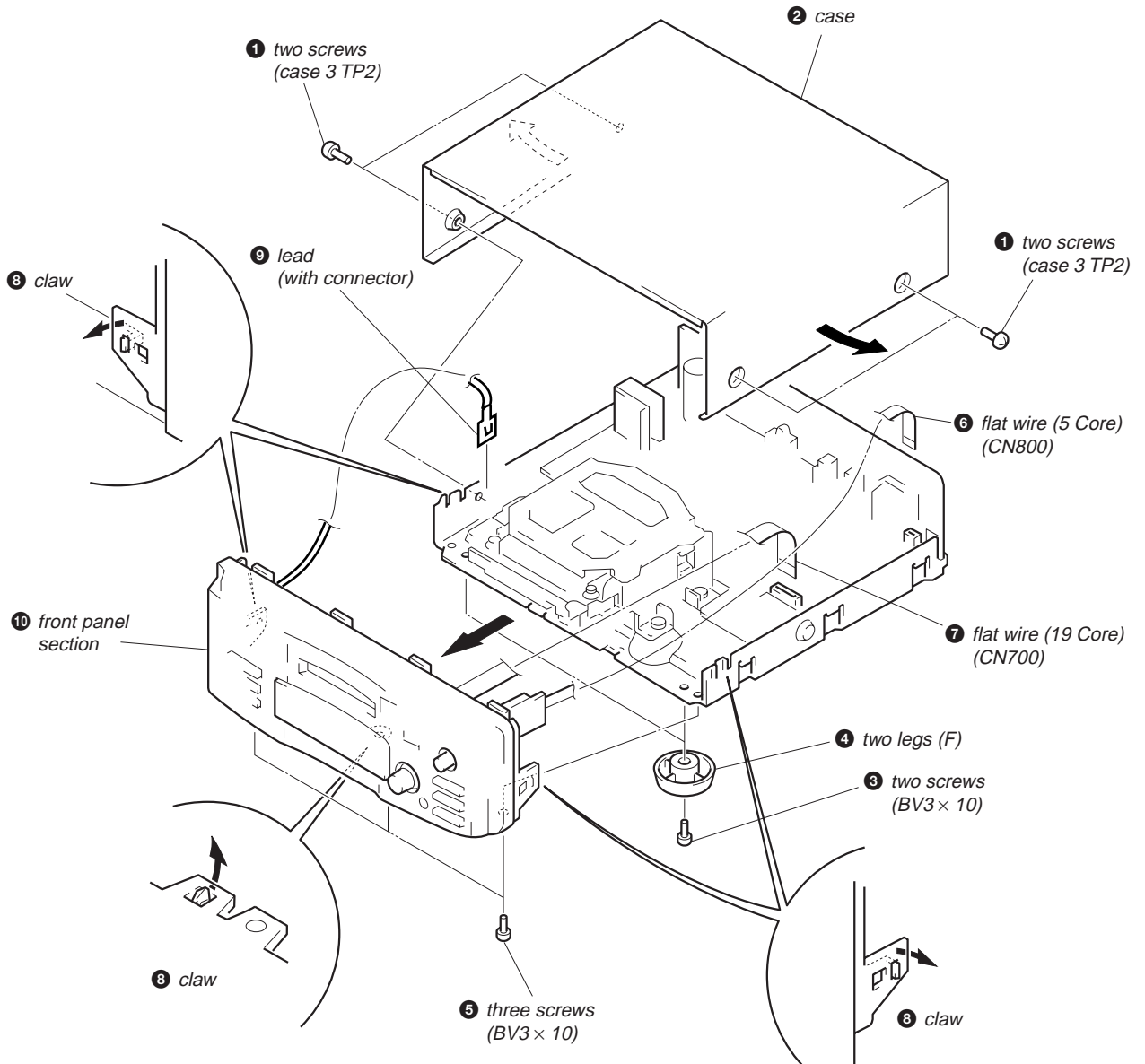

MECHANISM DECK

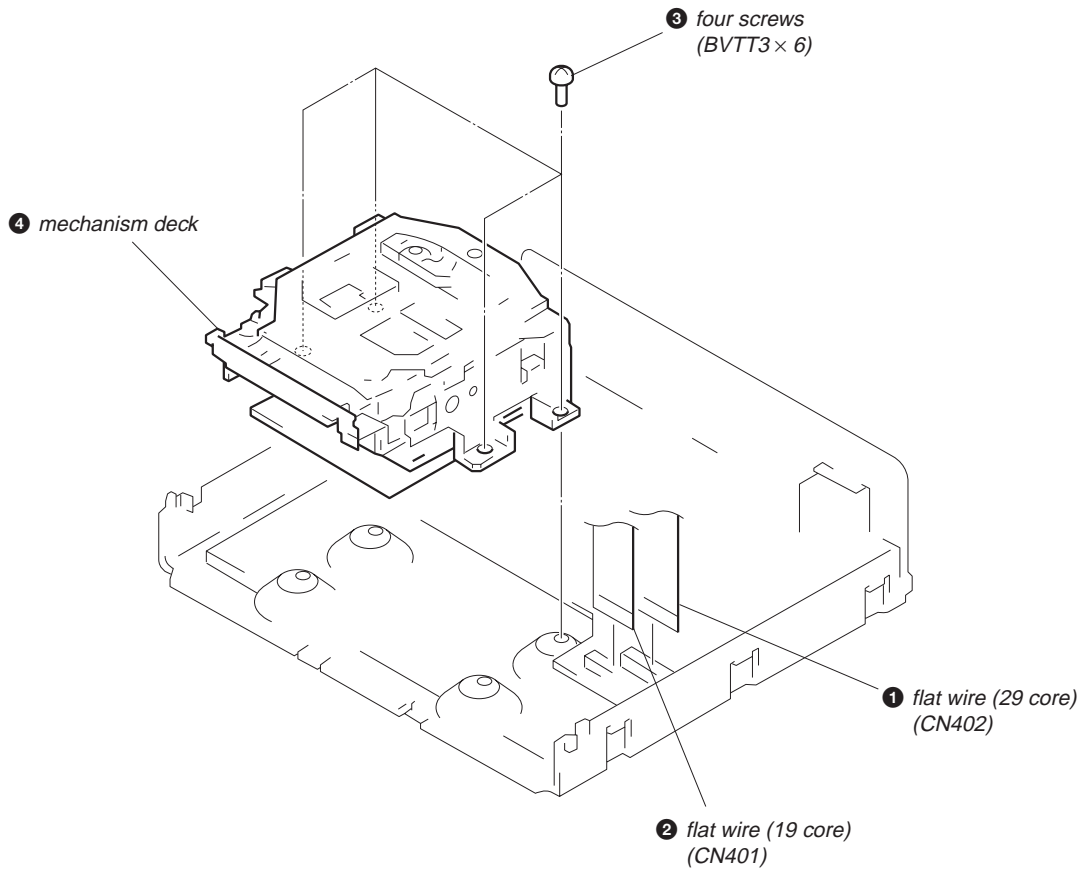

BRACKET (T), (L), (R)

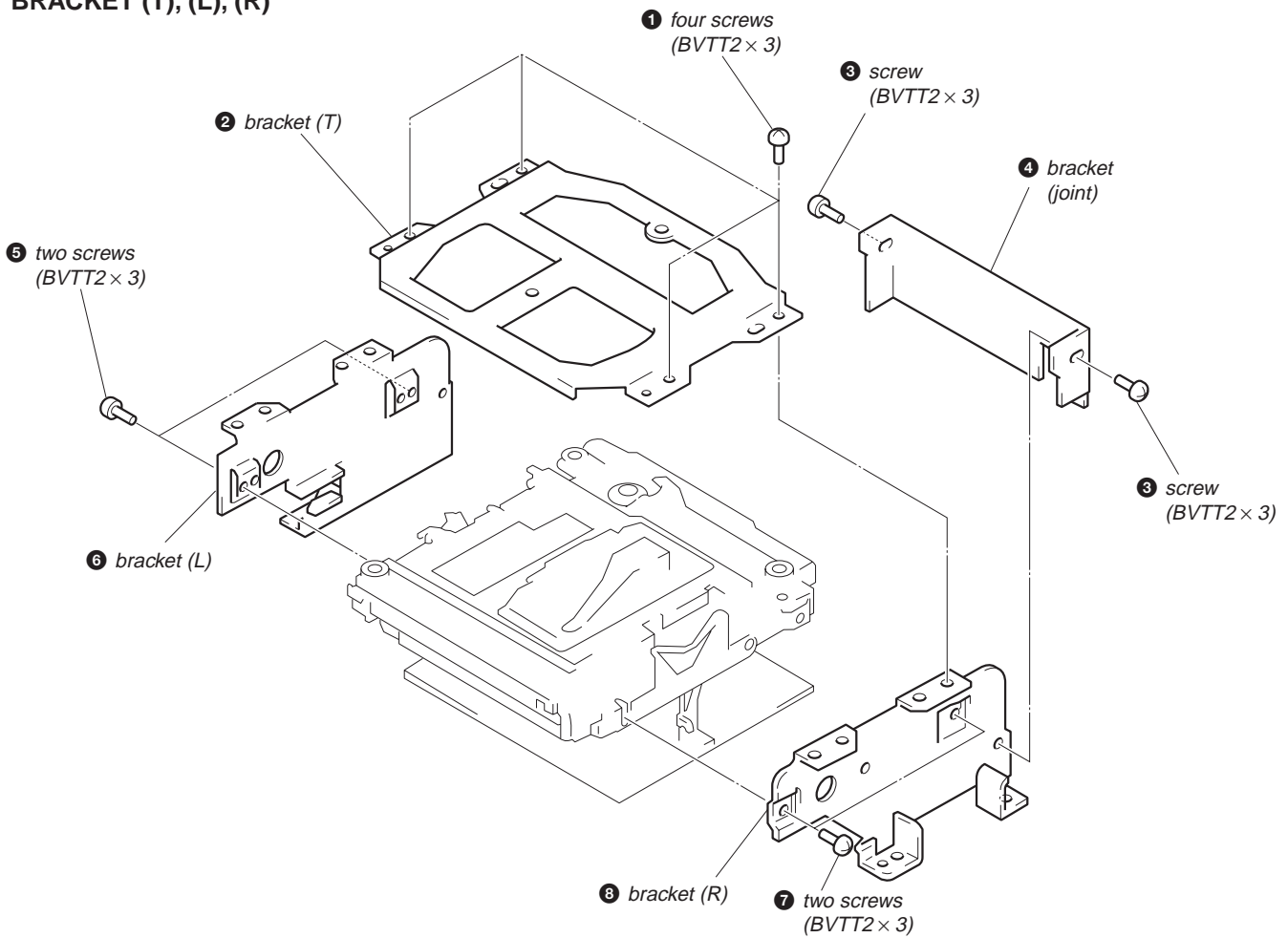

BD BOARD

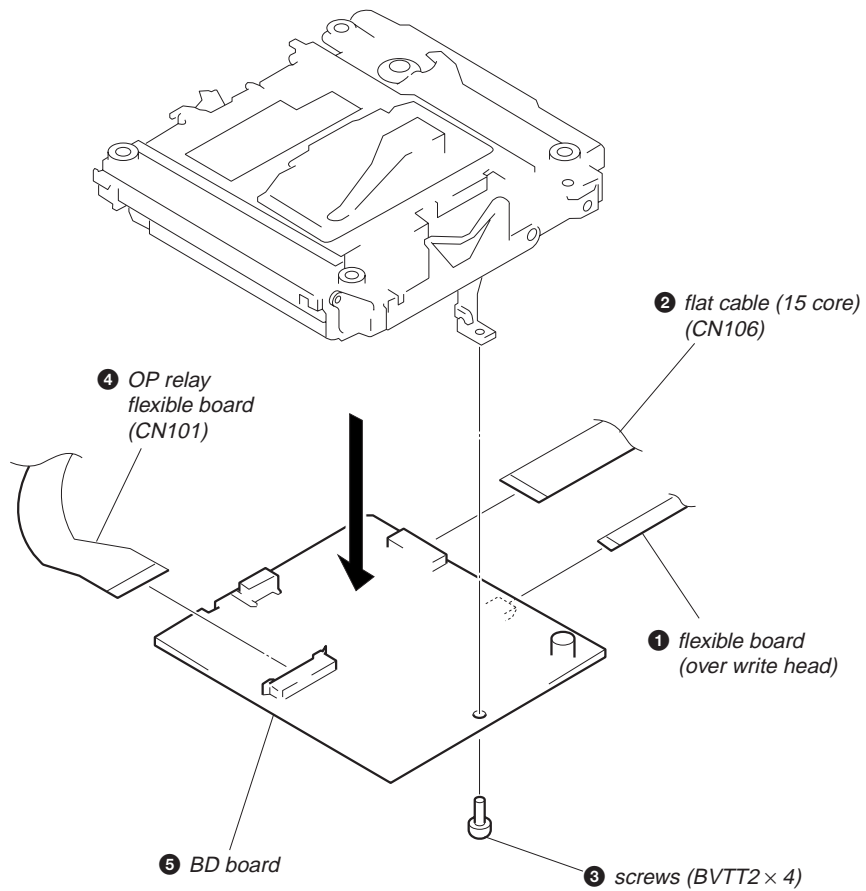

SUB CHASSIS

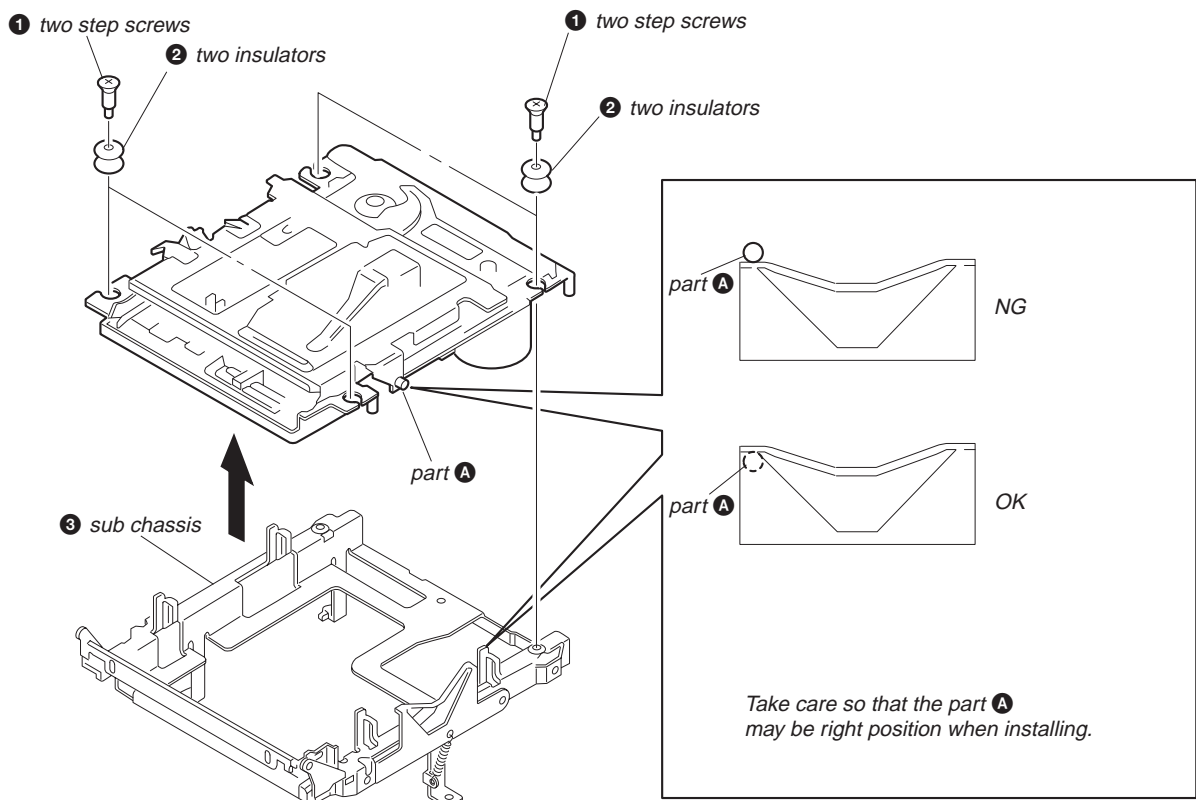

SHUTTER ASS'Y

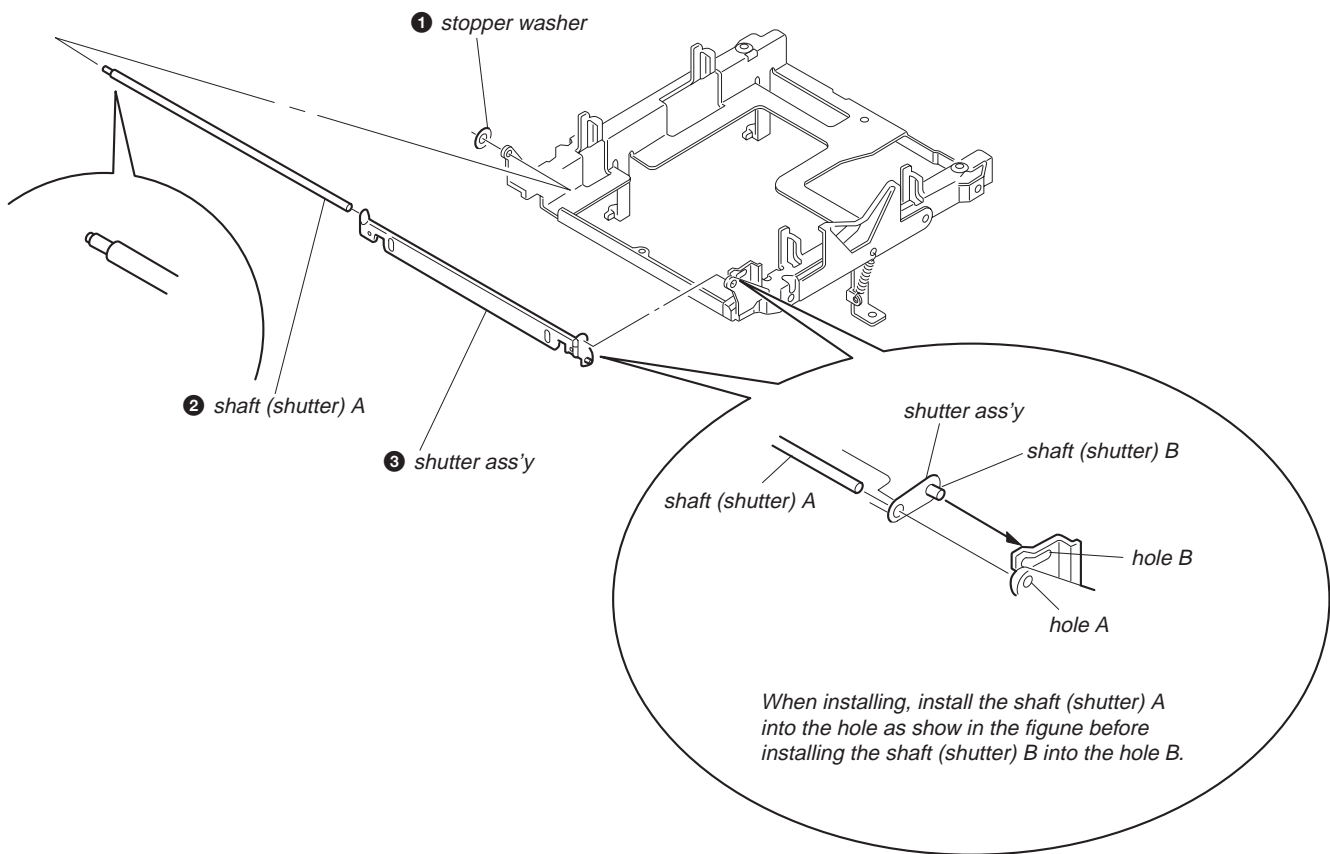

OVER WRITE HEAD

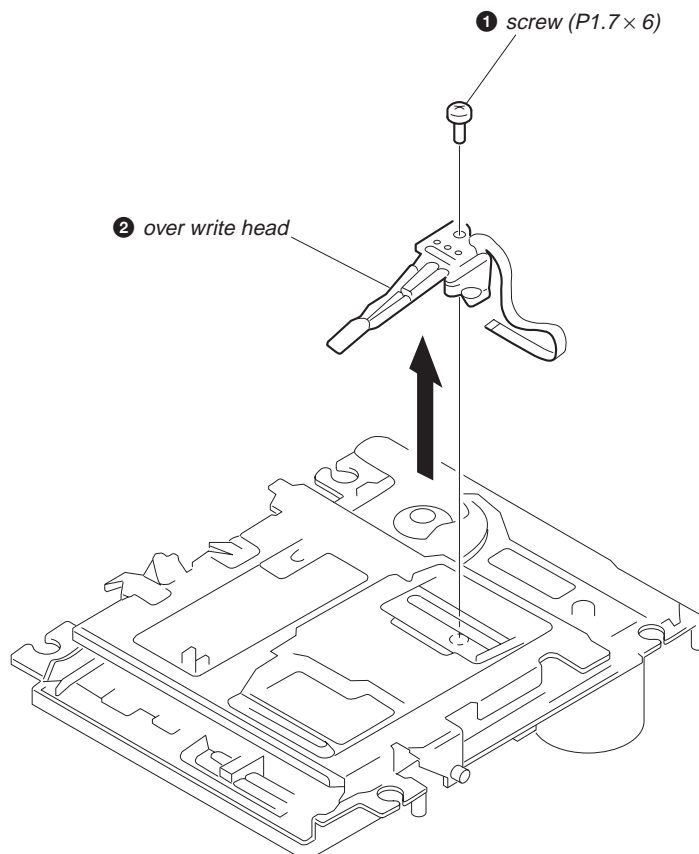

SLIDER COMPLETE ASS'Y

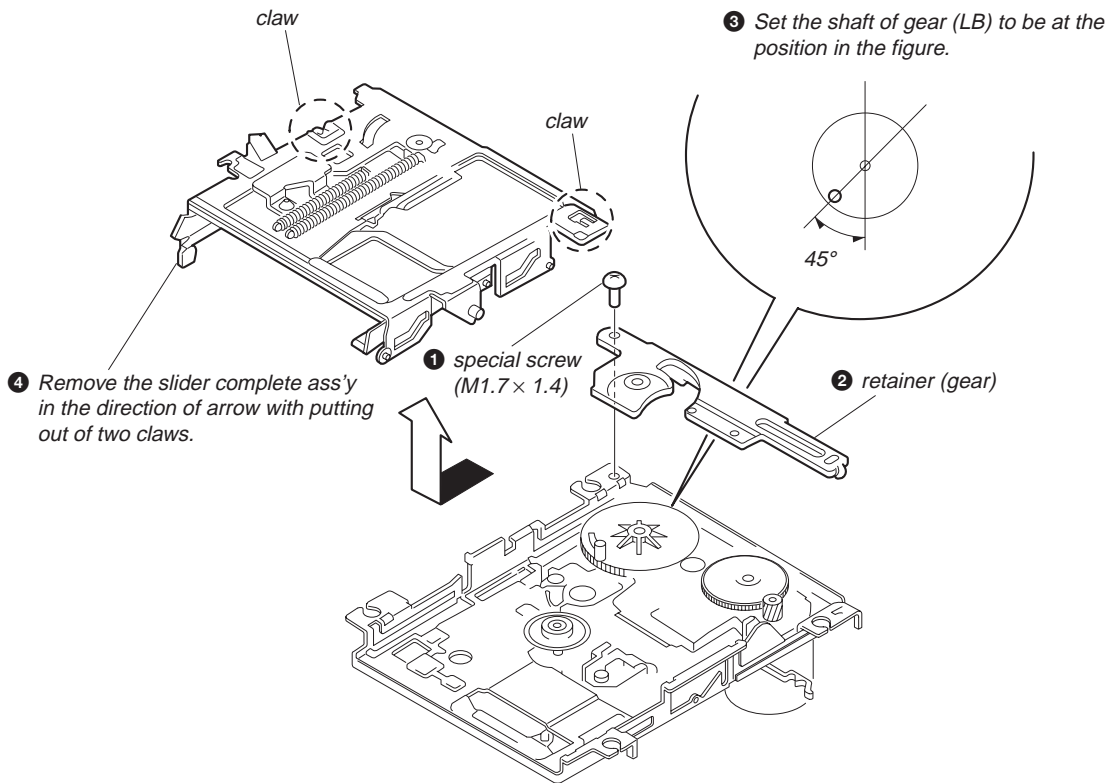

NOTE FOR INSTALLATION

• SLIDER COMPLETE ASS'Y

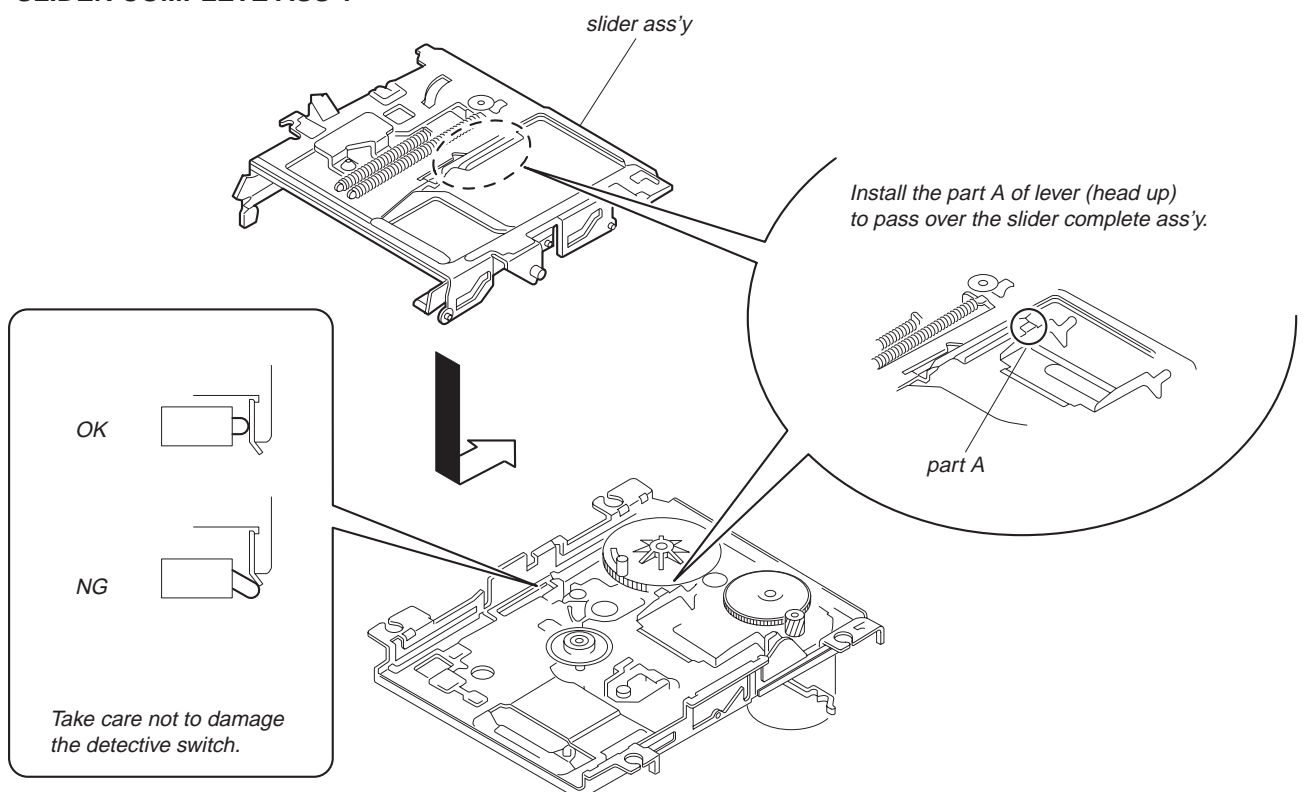

SECTION 4 TEST MODE

4-1. PRECAUTIONS FOR USE OF TEST MODE

1. As loading related operations will be performed regardless of the test mode operations being performed, be sure to check that the disc is stopped before setting and removing it. Even if the **EJECT** button is pressed while the disc is rotating during continuous playback, continuous recording, etc., the disc will not stop rotating. Therefore, it will be ejected while rotating. Be sure to press the **EJECT** button after pressing the **EDIT/NO** button and the rotation of disc is stopped.
2. The erasing-protection tab is not detected in the test mode. Therefore, operating in the recording laser emission mode and pressing the **REC** button, the recorded contents will be erased regardless of the position of the tab. When using a disc that is not to be erased in the test mode, be careful not to enter the continuous recording mode and traverse adjustment mode.

4-1-1. Recording Laser Emission Mode and Operating Button

1. Continuous recording mode (CREC MODE)
2. Traverse adjustment mode (EFBAL ADJUST)
3. Laser power adjustment mode (LDPWR ADJUST)
4. Laser power check mode (LDPWR CHECK)
5. When pressing the **REC** button.

4-2. SETTING THE TEST MODE

With the power supply to the set in OFF (standby) status, while pressing the **CD SYNC** button simultaneously, insert the power cord of TA-EX77 (pre/main amplifier system) or power feed jig (PFJ-1) into the power outlet, then release the button.

4-3. RELEASING THE TEST MODE

Press the **REPEAT** button, and the power is turned OFF (standby status), and the set becomes ready for normal operation.

4-4. BASIC OPERATIONS OF THE TEST MODE

All operations are performed using the **SELECTOR** knob, **EDIT/NO** button, and **ENTER/YES** button. The functions of these buttons and knob are as follows.

Table 4-1.

Button & Knob	Function
SELECTOR knob	Changes parameters and modes.
ENTER/YES button	Proceeds onto the next step. Finalizes input.
EDIT/NO button	Returns to previous step. Stops operations

4-5. SELECTING THE TEST MODE

Thirteen test modes are selected by turning the **SELECTOR** knob.

Table 4-2.

Display	Contents
TEMP ADJUST	Temperature compensation offset adjustment
LDPWR ADJUST	Laser power adjustment
LDPWR CHECK	Laser power check
EFBAL ADJUST	Traverse (E-F balance) adjustment
FBIAS ADJUST	Focus bias adjustment
FBIAS CHECK	Focus bias check
CPLAY MODE	Continuous playback mode
CREC MODE	Continuous recording mode
DETRK CHECK	Detrack check
Scurve CHECK	S curve check (*1)
EEP MODE	Non-volatile memory mode (*1)
MANUAL CMD	Manual command transfer mode (*1)
SVDATA READ	Data reading out mode (*1)

- For detailed description of each adjustment mode, refer to the “5. ELECTRICAL ADJUSTMENTS”.
- If a different adjustment mode has been selected by mistake, press the **EDIT/NO** button to exit from it.

*1: The EEP MODE, Scurve CHECK, MANUAL CMD and SVDATA READ are not used in servicing. If set accidentally, press the **EDIT/NO** button immediately to exit it.

4-6. OPERATING THE CONTINUOUS PLAYBACK MODE

4-6-1. Entering the Continuous Playback Mode

1. Set the disc in the unit. (Whichever recordable discs or discs for playback only are available.)
2. Turning the **[SELECTOR]** knob and display “CPLAY MODE”.
3. Press the **[ENTER/YES]** button to change the display to “CPLAY MID”.
4. When access completes, the display changes to “C1= 0000 AD= 00”.

Note: The numbers “0” displayed show you error rates and ADER.

4-6-2. Changing the Parts to be Played-back

1. Press the **[ENTER/YES]** button during continuous playback to change the display as below.



2. When access completes, the display changes to “C1= 0000 AD= 00”.

Note: The numbers “0” displayed show you error rates and ADER.

4-6-3. Ending the Continuous Playback Mode

1. Press the **[EDIT/NO]** button. The display will change to “CPLAY MODE”.
2. Press the **[EJECT]** button and remove the disc.

Notes:

1. The playback start address for IN, MID, and OUT are as follows.
 IN : 40h cluster
 MID : 300h cluster
 OUT : 700h cluster
 In case you want to display the address of the playback position on the display, press the **[DISPLAY/CHARACTER]** button and display “CPLAY (0000)”.
2. The **[EDIT/NO]** button can be used to stop playing anytime.

4-7. OPERATING THE CONTINUOUS RECORDING MODE

4-7-1. Entering the Continuous Recording Mode

1. Set the MO disc in the unit. (Refer to note 3.)
2. Turning the **[SELECTOR]** knob and display “CREC MODE”.
3. Press the **[ENTER/YES]** button to change the display to “CREC MID”.
4. When access completes, the display changes to “CREC (0000)” and **[REC]** lights up.

Note: The numbers “0” displayed shows you the recording position address.

4-7-2. Changing the Parts to be Recorded

1. When the **[ENTER/YES]** button is pressed during continuous recording, the display changes as below. (**[REC]** indication turns off during change-over of display.)



2. When access completes, the display changes to “CREC (0000)” and **[REC]** lights up.

Note: The numbers “0” displayed shows you the recording position address.

4-7-3. Ending the Continuous Recording Mode

1. Press the **[EDIT/NO]** button. The display will change to “CREC MODE” and **[REC]** goes off.
2. Press the **[EJECT]** button and remove the disc.

Notes:

1. The recording start address for IN, MID, and OUT are as follows.
 IN : 40h cluster
 MID : 300h cluster
 OUT : 700h cluster
2. The **[EDIT/NO]** button can be used to stop recording anytime.
3. During the test mode, the erasing-protection tab will not be detected. Therefore be careful not to set the continuous recording mode when a disc not to be erased is set in the unit.
4. Do not perform continuous recording for long periods of time above 5 minutes.
5. During continuous recording, be careful not to apply vibration.

4-8. EEP MODE

This mode reads and writes the contents of the non-volatile memory.

It is not used in servicing. If set accidentally, press the [EDIT/NO] button immediately to exit it.

4-9. FUNCTIONS OF OTHER BUTTONS

Table 4-3.

Button	Contents
▷	Sets continuous playback when pressed in the STOP state. (servo all on) When pressed during continuous playback, the tracking and sled servo turns on/off.
■	Stop continuous playback and continuous recording. (servo all off)
▶▶	The sled moves to the outer circumference only when this is pressed.
◀◀	The sled moves to the inner circumference only when this is pressed.
● REC	Turns recording on/off when pressed during continuous playback.
SCROLL	Switches between the pit and groove modes when pressed.
PROGRAM	Switches between the CLV-S (pull-in mode) and CLV-A (playing servo) modes when pressed. (Switches the spindle servo mode.)
DISPLAY/CHARACTER	Switches the display when pressed. Returns to previous step. Stop operations.
≡ EJECT	Disc eject

Note: The erasing-protection tab is not detected during the test mode. Recording will start regardless of the position of the erasing-protection tab when the [● REC] button is pressed.

4-10. TEST MODE DISPLAYS

Each time the [DISPLAY/CHARACTER] button is pressed, the display changes in the following order.

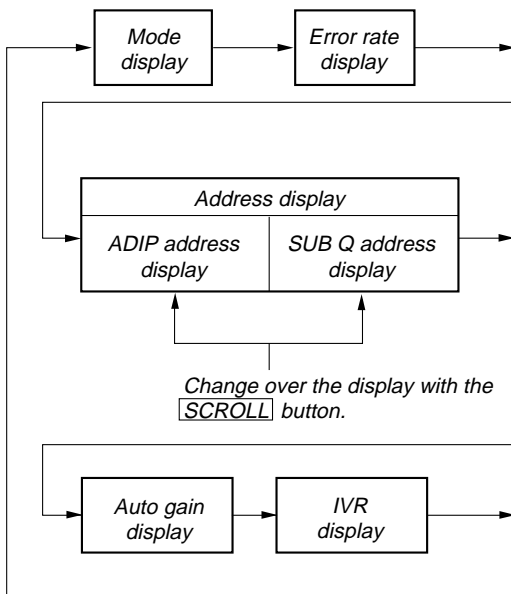

Note: Auto gain display and IVR display are not used in servicing.

1. MODE display
Displays “TEMP ADJUST”, “CPLAY MODE”, etc..

2. Error rate display
Error rates are displayed as follows.
C1= 0000 AD= 00
C1= : Indicates C1 error
AD= : Indicates ADER

3. Address display
Address are displayed as follows.
h= 0000 a= 0000 (MO groove)
With this display, if [SCROLL] button is pressed, the following will be displayed.
h= 0000 s= 0000 (MO pit and CD)
h=: Header address
s=: SUB Q address
a=: ADIP address

Note: “—” is displayed when the address cannot be read.

4. Auto gain display
Auto gain are displayed as follows.
AG F= 00 T= 00
F= Focus auto gain collection value
T= Tracking auto gain collection value

4-11. MEANINGS OF OTHER DISPLAYS

Table 4-4.

Display	Contents		
	Light	Off	Blinking
▶	During continuous playback (servo all on)	Stop state (servo all off)	—
	Tracking and sled servo off	Tracking and sled servo on	—
REC	Recording mode on	Recording mode off	—
CLOCK	CLV lock state	CLV unlock state	—
TRACK	Pit mode	Groove mode	—
DISC	High reflection rate disc	Low reflection rate disc	—
DATE	Spindle servo CLV-S (pull-in mode)	Spindle servo CLV-A (playing mode)	—
A.SPACE	ABCD adjustment completed	Not adjustment	—
A-B	Focus auto gain and tracking auto gain successful	—	Focus auto gain successful, tracking auto gain failed

SECTION 5 ELECTRICAL ADJUSTMENTS

5-1. PRECAUTIONS FOR CHECKING LASER DIODE EMISSION

To check the emission of the laser diode during adjustments, never view directly from the top as this may lose your eyesight.

5-2. PRECAUTIONS FOR USE OF OPTICAL PICK-UP (KMS-260A)

As the laser diode in the optical pick-up is easily damaged by static electricity, solder the laser tap of the flexible board when using it.

Before disconnecting the connector, desolder first. Before connecting the connector, be careful not to remove the solder. Also take adequate measures to prevent damage by static electricity. Handle the flexible board with care as it breaks easily.

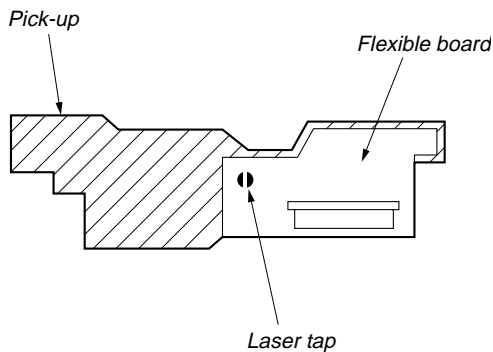

Optical pick-up flexible board

5-3. PRECAUTIONS FOR ADJUSTMENTS

1) When replacing the following parts, perform the adjustments and checks with ○ in the order shown in the following table.

Table 5-1.

	Optical Pick-up	BD board		
		IC171	D101	IC101, IC121, IC192
1. Temperature compensation offset adjustment	×	○	○	○
2. Laser power adjustment	○	○	×	○
3. Traverse adjustment	○	○	×	○
4. Focus bias adjustment	○	○	×	○
5. Error rate check	○	○	×	○

- 2) Set the test mode when performing adjustments. After completing the adjustments, exit the test mode.
- 3) Perform the adjustments in the order shown.
- 4) Use the following tools and measuring devices.
 - Check Disc (MD) TDYS-1 (Parts No. 4-963-646-01)
 - Laser power meter LPM-8001 (Parts No. J-2501-046-A)
 - Oscilloscope (Measure after performing CAL of prove.)
 - Digital voltmeter
 - Thermometer
- 5) When observing several signals on the oscilloscope, etc., make sure that VC and ground do not connect inside the oscilloscope. (VC and ground will become short-circuited)

5-4. CREATING MO CONTINUOUSLY RECORDED DISC

* This disc is used in focus bias adjustment and error rate check. The following describes how to create a MO continuous recording disc.

1. Set the test mode.
2. Insert a MO disc (blank disc) commercially available.
3. Turning the **[SELECTOR]** knob and display "CREC MODE".
4. Press the **[ENTER/YES]** button and display "CREC MID". "CREC (0300)" is displayed for a moment and recording starts.
5. Complete recording within 5 minutes.
6. Press the **[EDIT/NO]** button and stop recording.
7. Press the **[EJECT]** button and remove the MO disc.

The above has been how to create a continuous recording data for the focus bias adjustment and error rate check.

Note: Be careful not to apply vibration during continuous recording.

5-5. TEMPERATURE COMPENSATION OFFSET ADJUSTMENT

Save the temperature data at that time in the non-volatile memory as 25 °C reference data.

Notes:

1. Usually, do not perform this adjustment.
2. Perform this adjustment in an ambient temperature of 22 °C to 28 °C. Perform it immediately after the power is turned on when the internal temperature of the unit is the same as the ambient temperature of 22 °C to 28 °C.
3. When D101 has been replaced, perform this adjustment after the temperature of this part has become the ambient temperature.

Adjusting Method:

1. Turning the **[SELECTOR]** knob and display “TEMP ADJUST”.
2. Press the **[ENTER/YES]** button and select the “TEMP ADJUST” mode.
3. “TEMP = $\square\square\square$ ” and the current temperature a data will be displayed.
4. To save the data, press the **[ENTER/YES]** button.
When not saving the data, press the **[EDIT/NO]** button.
5. When the **[ENTER/YES]** button is pressed, “TEMP= $\square\square\square$ SAVE” will be displayed for some time, followed by “TEMP ADJUST”.
When the **[EDIT/NO]** button is pressed, “TEMP ADJUST” will be displayed immediately.

Specifications:

The temperature should be within “E0-EF”, “F0-FF”, “00-0F”, “10-1F” and “20-2F”.

5-6. LASER POWER ADJUSTMENT

Connection:

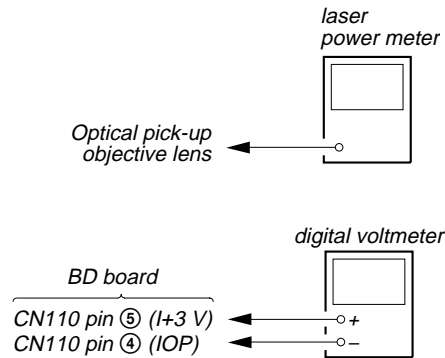

Adjusting Method:

1. Set the laser power meter on the objective lens of the optical pick-up. (When it cannot be set properly, press the **[◀◀]** button or **[▶▶]** button and move the optical pick-up.)
Connect the digital voltmeter to CN110 pin 5 (I+3 V) and CN110 pin 4 (IOP) of the BD board.
 2. Turning the **[SELECTOR]** knob and display “LDPWR ADJUST”.
(Laser power: for adjustment)
 3. Press the **[ENTER/YES]** button and display “LD 0.9 mW $\square\square\square$ ”.
 4. Turning the **[SELECTOR]** knob so that the reading of the laser power meter becomes 0.82 to 0.91 mW.
Set the range control on the laser power meter to 10 mW, then press the **[ENTER/YES]** button to save the adjustment result in the non-volatile memory.
(“LD SAVE $\square\square\square$ ” will be displayed for a moment.)
 5. Then “LD 7.0 mW $\square\square\square$ ” will be displayed.
 6. Turning the **[SELECTOR]** knob so that the reading of the laser power meter becomes 6.9 to 7.1 mW, press the **[ENTER/YES]** button and save the adjustment result in the non-volatile memory.
(“LD SAVE $\square\square\square$ ” will be displayed for a moment.)
- Note:** Do not perform the emission with 7.0 mW more than 15 seconds continuously.
7. Turning the **[SELECTOR]** knob and display “LDPWR CHECK”.
 8. Press the **[ENTER/YES]** button and display “LD 0.9 mW $\square\square\square$ ”.
Check that the reading of the laser power meter becomes 0.80 to 0.96 mW.
 9. Press the **[ENTER/YES]** button and display “LD 7.0 mW $\square\square\square$ ”.
Check that the reading of the laser power meter and digital voltmeter satisfy the specified value.

Specification:

Laser power meter reading : 7.0 ± 0.2 mW

Digital voltmeter reading : Optical pick-up displayed value $\pm 10\%$

(Optical pick-up label)

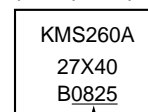

IOP=82.5 mA in this case

$IOP (mA) = \text{Digital voltmeter reading (mV)} / 1 (\Omega)$

10. Press the **[EDIT/NO]** button and display “LDPWR CHECK”, and stop the laser emission.
(The **[EDIT/NO]** button is effective at all times to stop the laser emission.)

5-7. TRAVERSE (E-F BALANCE) ADJUSTMENT

Note 1: Data will be erased during MO reading if a recorded disc is used in this adjustment.

Note 2: If the traverse waveform is not clear, connect the oscilloscope as shown in the following figure so that it can be seen more clearly.

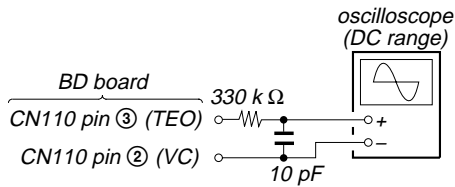

Connection:

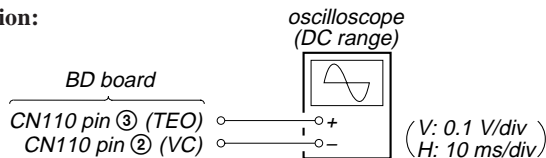

Adjusting Method:

1. Connect an oscilloscope to CN110 pin ③ (TEO) and CN110 pin ② (VC) of the BD board.
2. Load a MO disc (any available on the market). (Refer to note 1.)
3. Press the **◀** button or **▶** button and move the optical pick-up outside the pit.
4. Turning the **SELECTOR** knob and display "EFBAL ADJUST".
5. Press the **ENTER/YES** button and display "EFB= MO-R". (Laser power READ power/focus servo ON/tracking servo OFF/spindle (S) servo ON)
6. Turning the **SELECTOR** knob so that the waveforms of the oscilloscope becomes the specified value. (When the **SELECTOR** knob is turned, the "" of "EFB= MO-R" changes and the waveform changes.)
In this adjustment, waveform varies at intervals of approx. 2%. Adjust the waveform so that the specified value is satisfied as much as possible.
(MO read power traverse adjustment)

(Traverse Waveform)

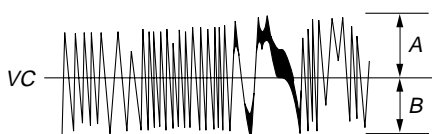

specification: A=B

7. Press the **ENTER/YES** button, and save the result of adjustment to the non-volatile memory. ("EFB= SAVE" will be displayed for a moment. Then "EFB= MO-W" will be displayed.)

8. Turning the **SELECTOR** knob so that the waveforms of the oscilloscope becomes the specified value. (When the **SELECTOR** knob is turned, the "" of "EFB= MO-W" changes and the waveform changes.)
In this adjustment, waveform varies at intervals of approx. 2%. Adjust the waveform so that the specified value is satisfied as much as possible.
(MO write power traverse adjustment)

(Traverse Waveform)

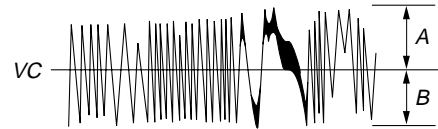

specification: A=B

9. Press the **ENTER/YES** button, and save the result of adjustment to the non-volatile memory. ("EFB= SAVE" will be displayed for a moment. Then "EFB= MO-P" will be displayed.)
10. The optical pick-up moves to the pit area automatically and servo is imposed.
11. Turning the **SELECTOR** knob until the waveforms of the oscilloscope moves closer to the specified value. In this adjustment, waveform varies at intervals of approx. 2%. Adjust the waveform so that the specified value is satisfied as much as possible.

(Traverse Waveform)

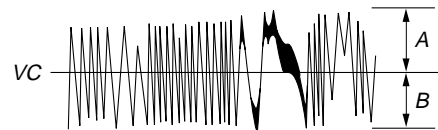

specification: A=B

12. Press the **ENTER/YES** button, and save the result of adjustment to the non-volatile memory. ("EFB= SAVE" will be displayed for a moment. Then "EFBAL CD" will be displayed.)
The disc stops rotating automatically.
13. Press the **EJECT** button and remove the MO disc.
14. Load the test disc TDYS-1.
15. Press the **ENTER/YES** button and display "EFB= CD". Servo is imposed automatically.
16. Turning the **SELECTOR** knob until the waveforms of the oscilloscope moves closer to the specified value. In this adjustment, waveform varies at intervals of approx. 2%. Adjust the waveform so that the specified value is satisfied as much as possible.

(Traverse Waveform)

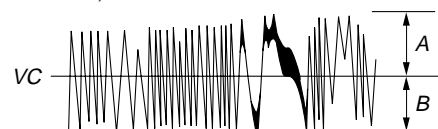

specification: A=B

17. Press the **ENTER/YES** button, and save the result of adjustment to the non-volatile memory. ("EFB= SAVE" will be displayed for a moment. Then "EFBAL ADJUST" will be displayed.)
18. Press the **EJECT** button and remove the test disc TDYS-1.

5-8. FOCUS BIAS ADJUSTMENT

Adjusting Method:

1. Load a continuously recorded disc (Refer to “5-4. Creating MO Continuously Recorded Disc”).
2. Turning the **[SELECTOR]** knob and display “CPLAY MODE”.
3. Press the **[ENTER/YES]** button and display “CPLAY MID”.
4. Press the **[EDIT/NO]** button when “C1= 0000 AD= 00” is displayed.
5. Turning the **[SELECTOR]** knob and display “FBIAS ADJUST”.
6. Press the **[ENTER/YES]** button and display “0000/00 a=00”. The first four digits indicate the C1 error rate, the two digits after [/] indicate ADER, and the 2 digits after [a=] indicate the focus bias value.
7. Turning the **[SELECTOR]** knob in the clockwise direction and find the focus bias value at which the C1 error rate becomes 220. (Refer to note 2.)
8. Press the **[ENTER/YES]** button and display “0000/00 b=00”.
9. Turning the **[SELECTOR]** knob in the counterclockwise direction and find the focus bias value at which the C1 error rate becomes 220. (Refer to note 2.)
10. Press the **[ENTER/YES]** button and display “0000/00 c=00”.
11. Check that the C1 error rate is below 50 and ADER is 00. Then press the **[ENTER/YES]** button.
12. If the “(00)” in “00-00-00 (00)” is above 20, press the **[ENTER/YES]** button.
If below 20, press the **[EDIT/NO]** button and repeat the adjustment from step 2 again.
13. Press the **[EDIT/NO]** button and press the **[EJECT]** button to remove the continuously recorded disc.

Note 1: The relation between the C1 error and focus bias is as shown in the following figure. Find points a and b in the following figure using the above adjustment. The focal point position c is automatically calculated from points a and b.

Note 2: As the C1 error rate changes, perform the adjustment using the average value.

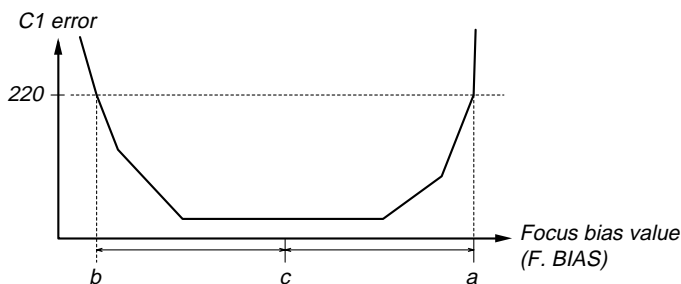

5-9. ERROR RATE CHECK

5-9-1. CD Error Rate Check

Checking Method:

1. Load a test disc TDYS-1.
2. Turning the **[SELECTOR]** knob and display “CPLAY MODE”.
3. Press the **[ENTER/YES]** button and display “CPLAY MID”.
4. “C1= 0000 AD= 00” is displayed.
5. Check that the C1 error is below 20.
6. Press the **[EDIT/NO]** button, stop playback, press the **[EJECT]** button, and remove the test disc.

5-9-2. MO Error Rate Check

Checking Method:

1. Load a continuously recorded disc (Refer to “5-4. Creating MO Continuously Recorded Disc”).
2. Turning the **[SELECTOR]** knob and display “CPLAY MODE”.
3. Press the **[ENTER/YES]** button and display “CPLAY MID”.
4. “C1=0000 AD=00” is displayed.
5. If the C1 error is below 50, check that ADER is 00.
6. Press the **[EDIT/NO]** button, stop playback, press the **[EJECT]** button, and remove the continuously recorded disc.

5-10. FOCUS BIAS CHECK

Change the focus bias and check the focus tolerance amount.

Checking Method:

1. Load a continuously recorded disc (Refer to “5-4. Creating MO Continuously Recorded Disc”).
2. Turning the **[SELECTOR]** knob and display “CPLAY MODE”.
3. Press the **[ENTER/YES]** button and display “CPLAY MID”.
4. Press the **[EDIT/NO]** button when “C1=0000 AD=00” is displayed.
5. Turning the **[SELECTOR]** knob and display “FBIAS CHECK”.
6. Press the **[ENTER/YES]** button and display “0000/00 c=00”. The first four digits indicate the C1 error rate, the two digits after [/] indicate ADER, and the 2 digits after [c=] indicate the focus bias value.
Check that the C1 error is below 50 and ADER is 00.
7. Press the **[ENTER/YES]** button and display “0000/00 b=00”. Check that the C1 error is not below 220 and ADER is not above 00 every time.
8. Press the **[ENTER/YES]** button and display “0000/00 a=00”. Check that the C1 error is not below 220 and ADER is not above 00 every time.
9. Press the **[EDIT/NO]** button, next press the **[EJECT]** button, and remove the continuously recorded disc.

Note 1: If the C1 error and ADER are above 00 at points a or b, the focus bias adjustment may not have been carried out properly. Adjust perform the beginning again.

SECTION 6 DIAGRAMS

5-11. ADJUSTING POINTS AND CONNECTING POINTS

• Circuit Boards Location

[BD BOARD] (COMPONENT SIDE)

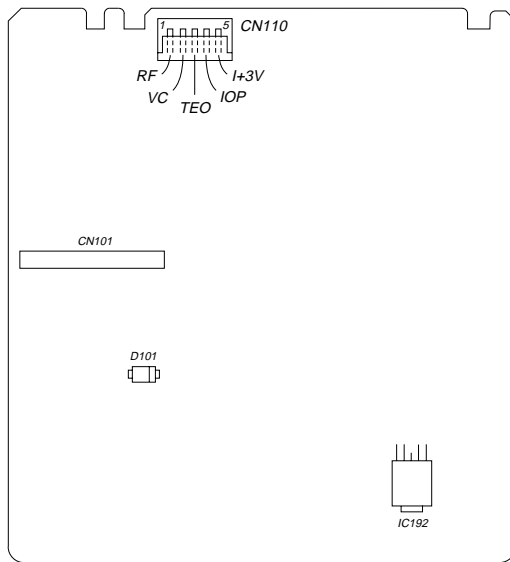

[BD BOARD] (CONDUCTOR SIDE)

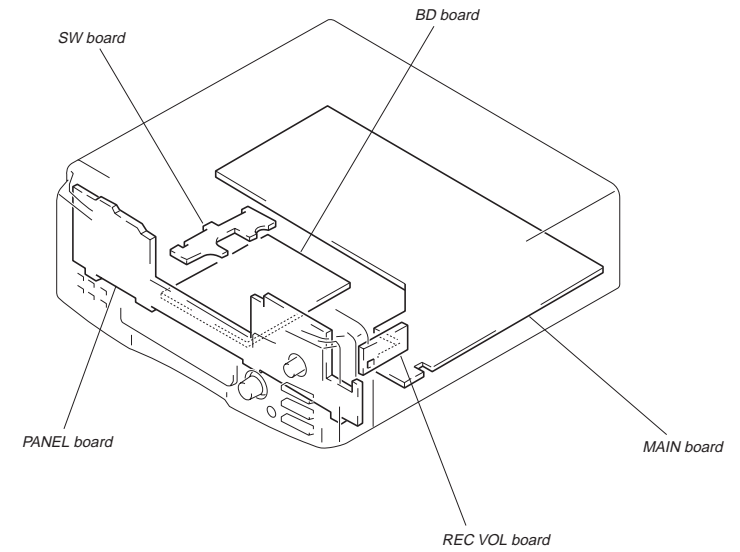
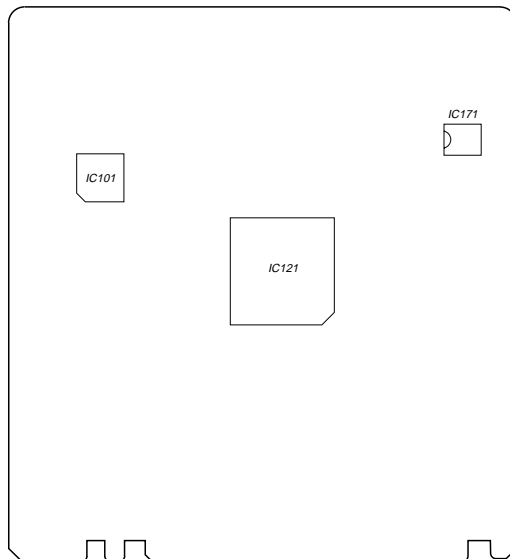

6-1. BLOCK DIAGRAM (1/2)

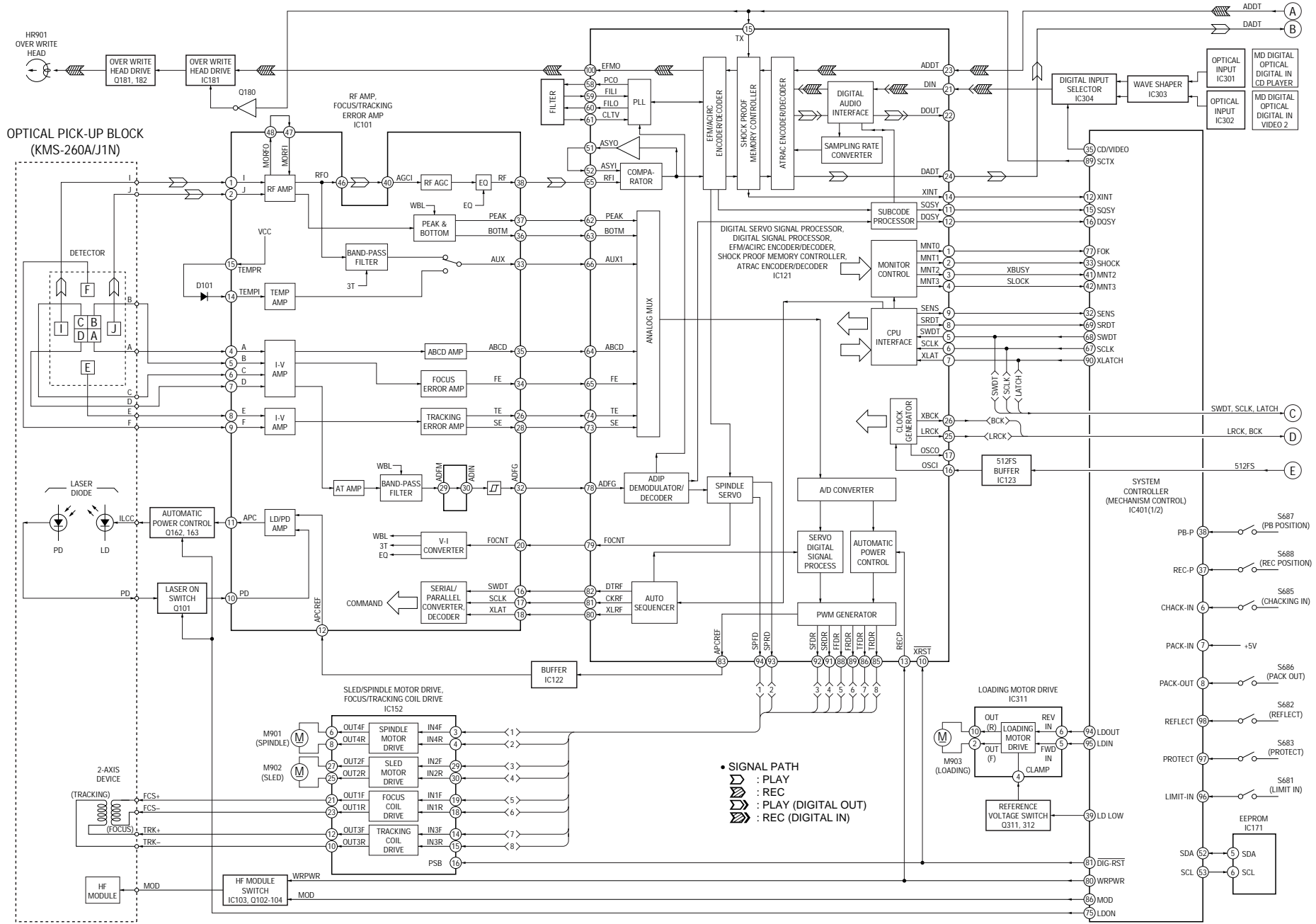

6-2. BLOCK DIAGRAM (2/2)

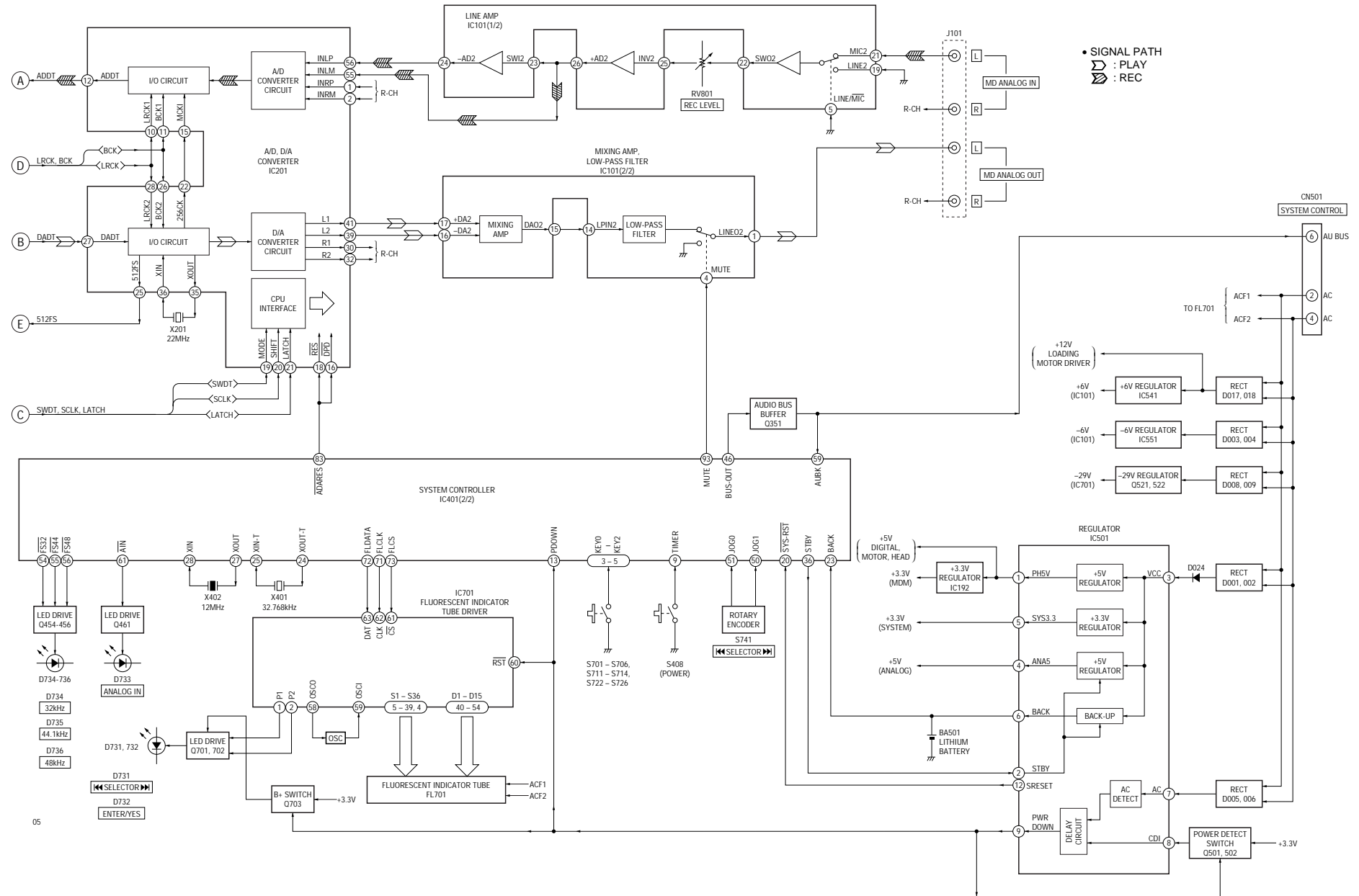

6-6. PRINTED WIRING BOARDS – MAIN/DISPLAY Section –
• See page 32 for Circuit Boards Location.

• Waveforms

– MD MECHANISM DECK Section –

1 IC101 ①, ② (I, J) (Play Mode)

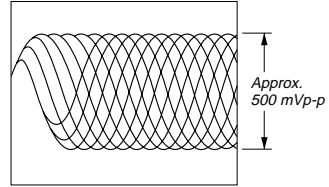

2 IC101 ④ (A) (Play Mode)

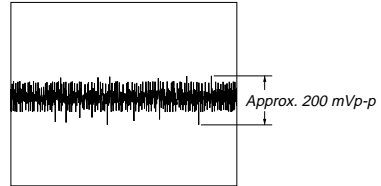

3 IC101 ⑥, ⑨ (E, F) (Play Mode)

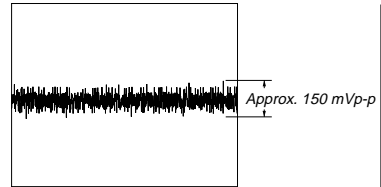

4 IC101 ⑩ (RF) (Play Mode)

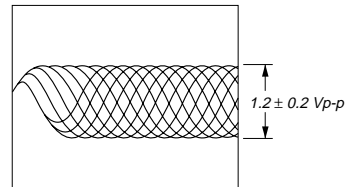

5 IC152 ③ (CAPA-) (Play Mode)

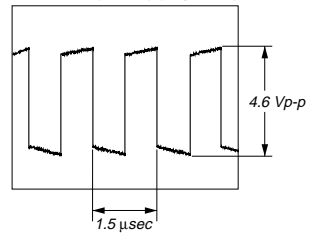

6 IC151 ④ (CAPA+) (Play Mode)

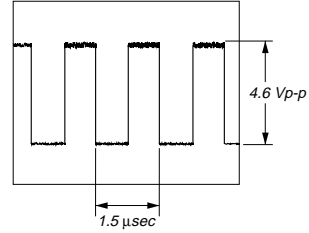

7 IC121 ④ (FS4)

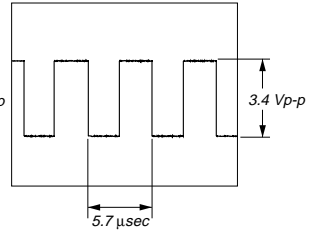

8 IC121 ⑩ (OSCI)

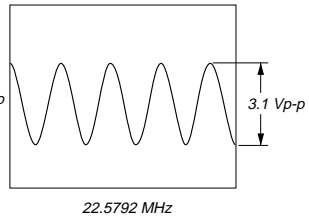

9 IC121 ⑫ (LRCK)

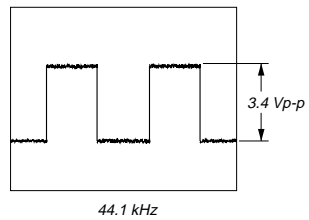

10 IC121 ⑬ (XBCK)

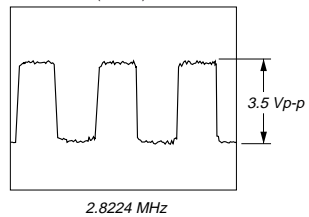

11 IC121 ⑮ (FS256)

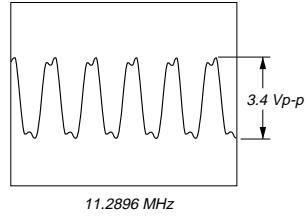

12 IC123 ①

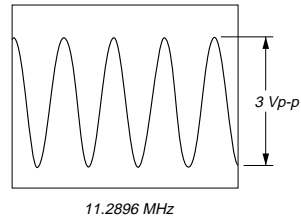

– MAIN/DISPLAY Section –

1 IC701 ⑩ (OSC0)

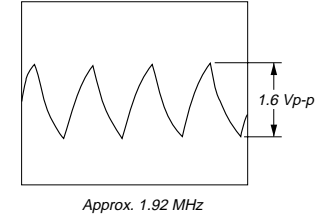

2 IC701 ⑫ (OSC1)

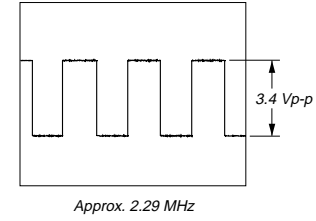

3 IC401 ⑰ (XOUT)

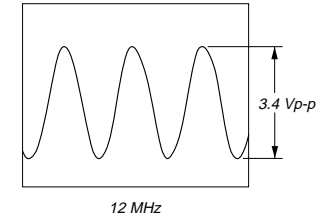

4 IC401 ⑲ (XOUT-T)

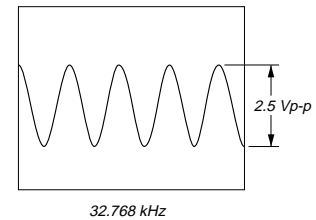

5 IC201 ⑩, ⑫ (LRCK1, LRCK2)

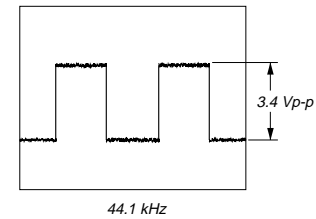

6 IC201 ⑪, ⑬ (BCK1, BCK2)

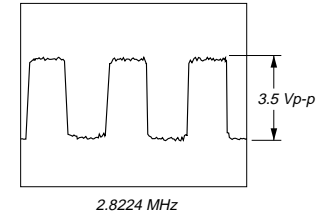

7 IC201 ⑭, ⑯ (MCK1, 256CK)

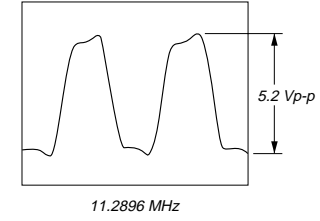

8 IC201 ⑰ (512FS)

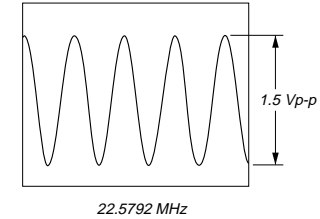

9 IC201 ⑱ (XOUT)

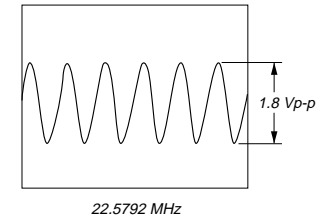

• IC Block Diagrams
 – MD MECHANISM DECK Section –

IC101 CXA2523R

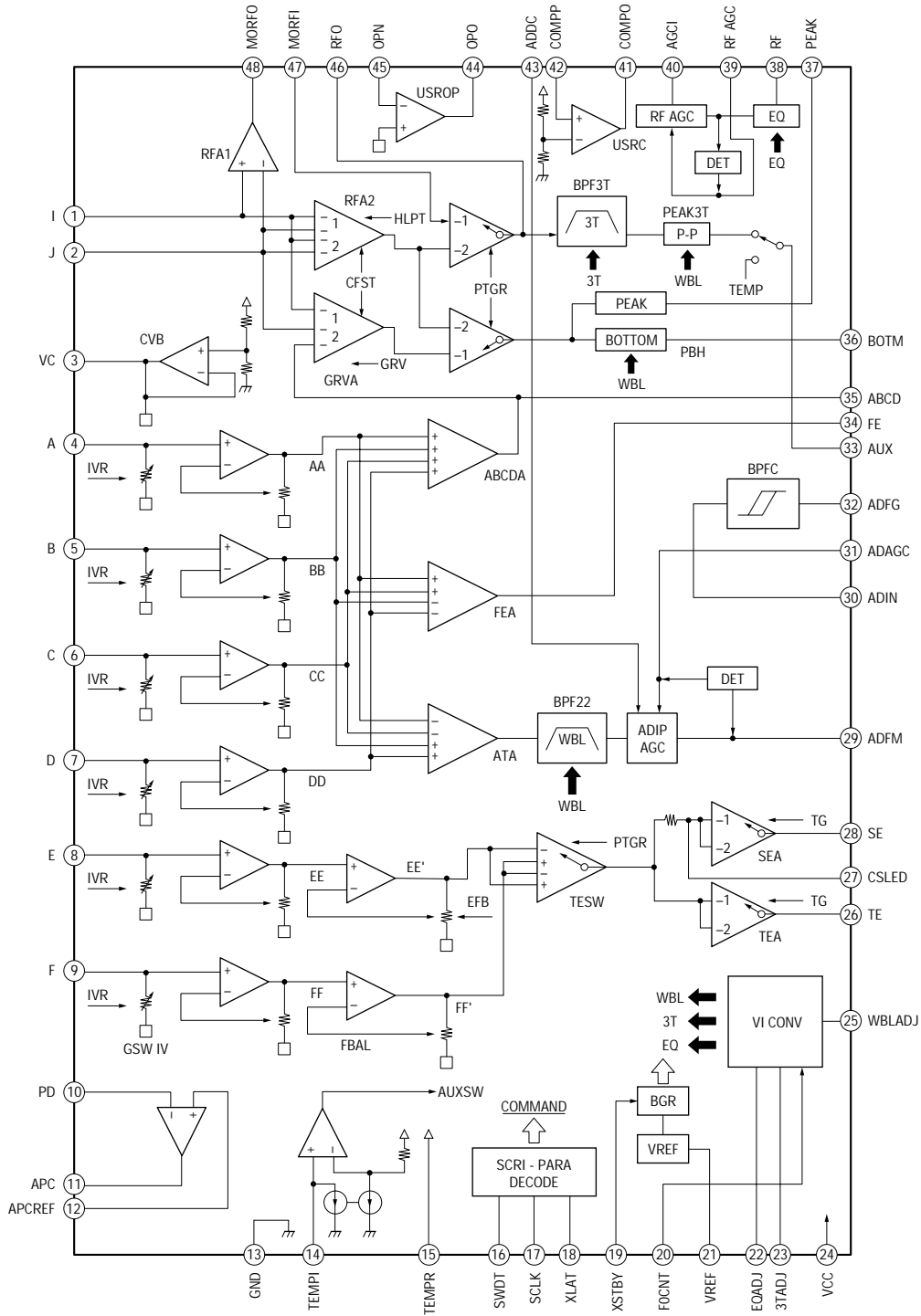

IC121 CXD2650R

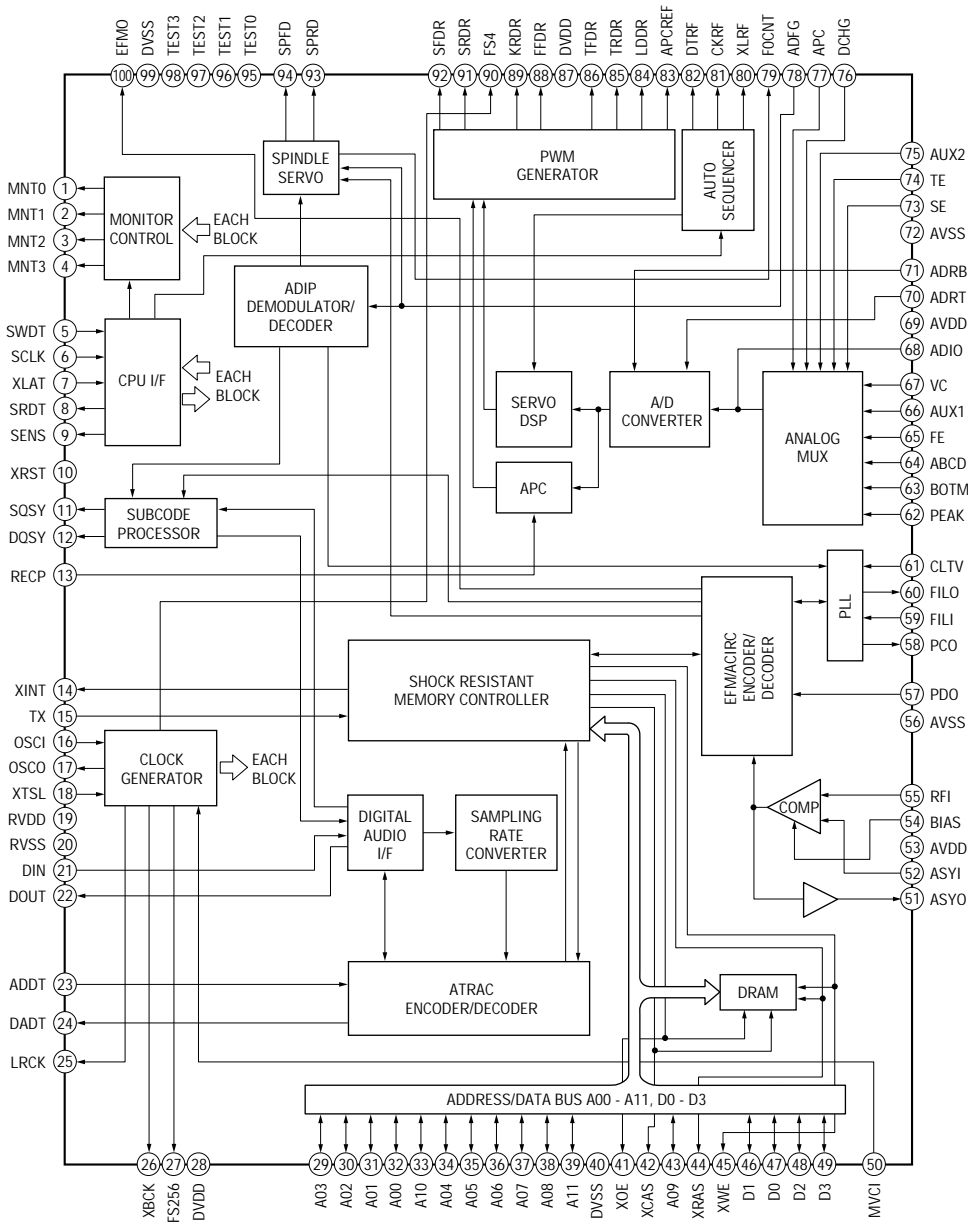

IC152 BH6511FS-E2

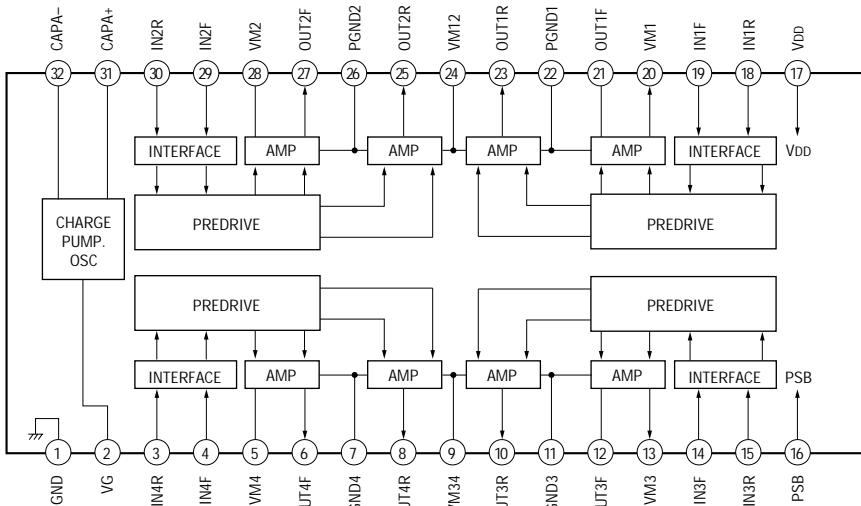

– MAIN/DISPLAY Section –

IC101 CXA8065S

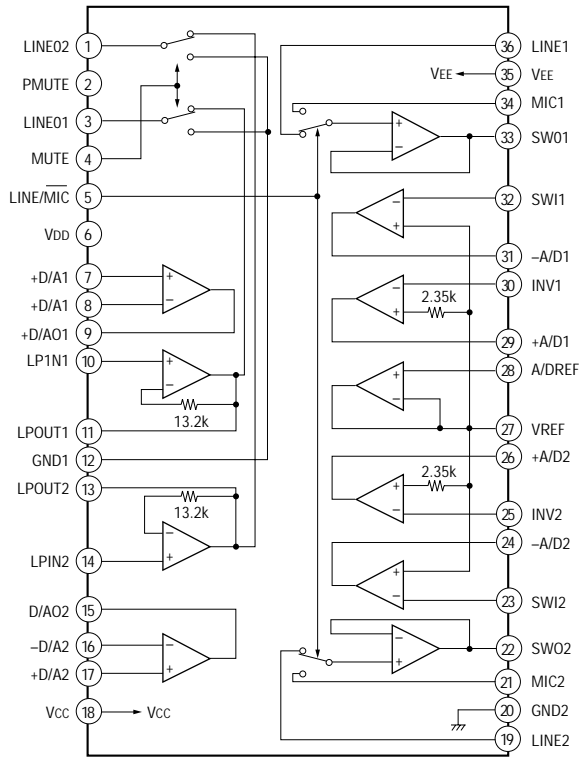

IC201 CXD8607N

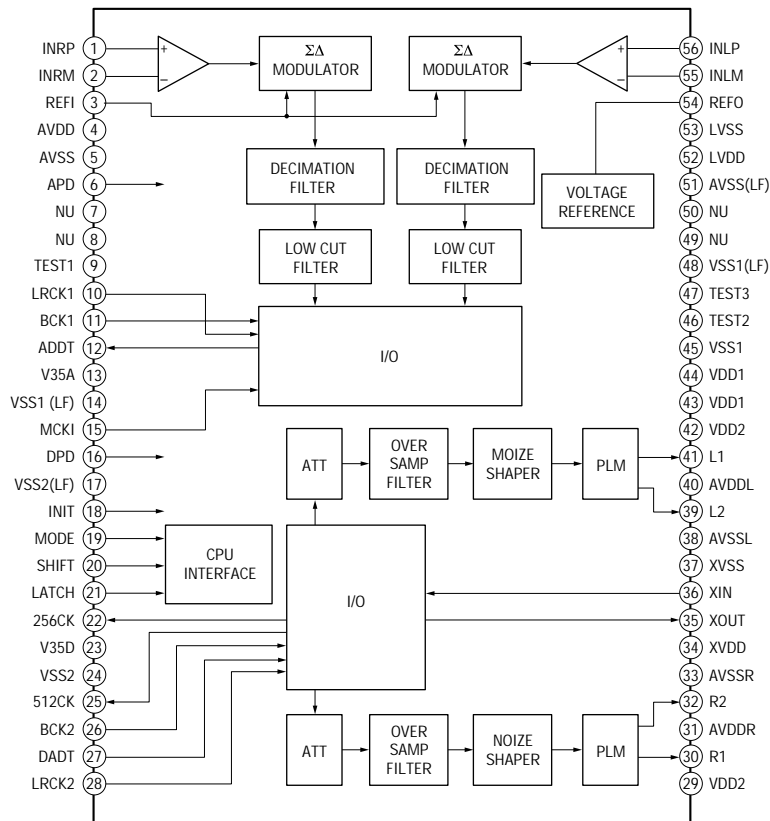

IC311 LB1641

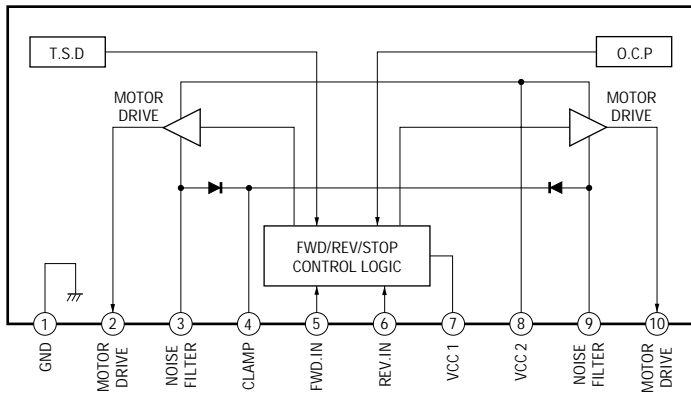

IC501 LA5620

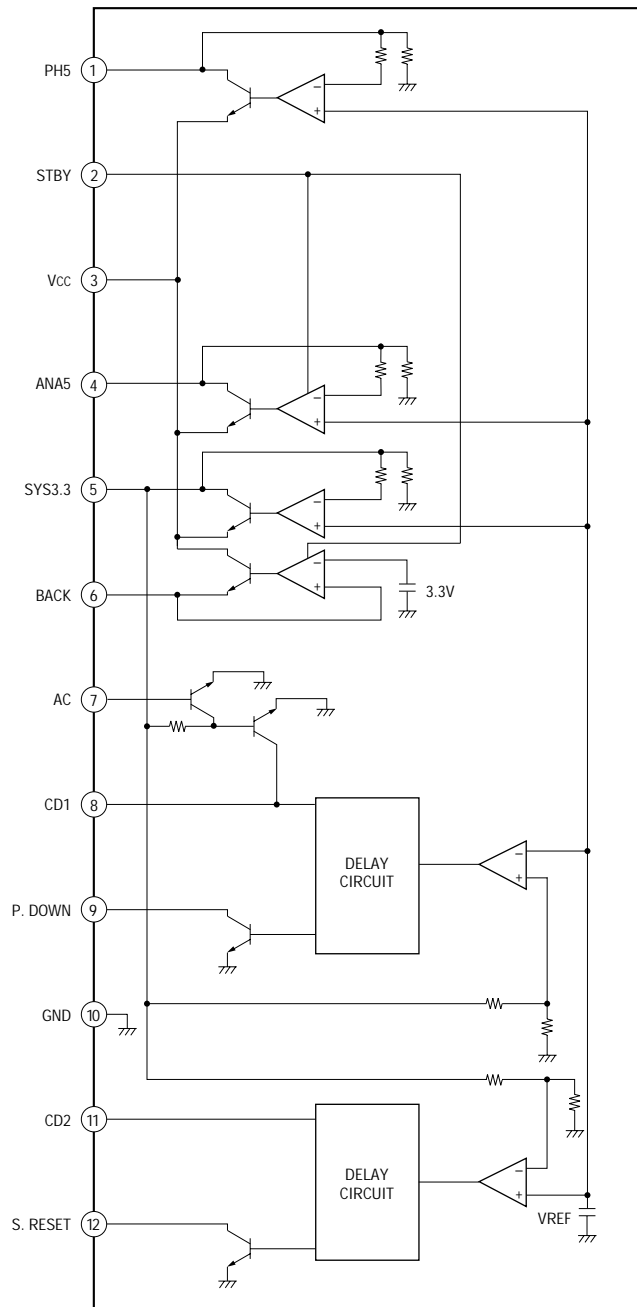

6-7. IC PIN FUNCTION DESCRIPTION

• BD BOARD IC101 CXA2523R (RF AMPLIFIER)

Pin No.	Pin Name	I/O	Function
1	I	I	I-V converted RF signal I input from the optical pick-up block detector
2	J	I	I-V converted RF signal J input from the optical pick-up block detector
3	VC	O	Middle point voltage (+1.65V) generation output terminal
4 to 9	A to F	I	Signal input from the optical pick-up detector
10	PD	I	Light amount monitor input terminal
11	APC	O	Laser amplifier output terminal to the automatic power control circuit
12	APCREF	I	Reference voltage input terminal for setting laser power
13	GND	—	Ground terminal
14	TEMPI	I	Connected to the temperature sensor
15	TEMPR	O	Output terminal for a temperature sensor reference voltage
16	SWDT	I	Writing serial data input from the CXD2650R (IC121)
17	SCLK	I	Serial clock signal input from the CXD2650R (IC121)
18	XLAT	I	Serial latch signal input from the CXD2650R (IC121)
19	XSTBY	I	Standby signal input terminal “L”: standby (fixed at “H” in this set)
20	FOCNT	I	Center frequency control voltage input terminal of internal circuit (BPF22, BPF3T, EQ) input from the CXD2650R (IC121)
21	VREF	O	Reference voltage output terminal Not used (open)
22	EQADJ	I	Center frequency setting terminal for the internal circuit (EQ)
23	3TADJ	I	Center frequency setting terminal for the internal circuit (BPF3T)
24	VCC	—	Power supply terminal (+3.3V)
25	WBLADJ	I	Center frequency setting terminal for the internal circuit (BPF22)
26	TE	O	Tracking error signal output to the CXD2650R (IC121)
27	CSLED	I	Connected to the external capacitor for low-pass filter of the sled error signal
28	SE	O	Sled error signal output to the CXD2650R (IC121)
29	ADFM	O	FM signal output of the ADIP
30	ADIN	I	Receives a ADIP FM signal in AC coupling
31	ADAGC	I	Connected to the external capacitor for ADIP AGC
32	ADFG	O	ADIP duplex signal (22.05 kHz \pm 1 kHz) output to the CXD2650R (IC121)
33	AUX	O	Auxiliary signal (I ₃ signal/temperature signal) output to the CXD2650R (IC121)
34	FE	O	Focus error signal output to the CXD2650R (IC121)
35	ABCD	O	Light amount signal (ABCD) output to the CXD2650R (IC121)
36	BOTM	O	Light amount signal (RF/ABCD) bottom hold output to the CXD2650R (IC121)
37	PEAK	O	Light amount signal (RF/ABCD) peak hold output to the CXD2650R (IC121)
38	RF	O	Playback EFM RF signal output to the CXD2650R (IC121)
39	RFAGC	I	Connected to the external capacitor for RF auto gain control circuit
40	AGCI	I	Receives a RF signal in AC coupling
41	COMPO	O	User comparator output terminal Not used (open)
42	COMPP	I	User comparator input terminal Not used (fixed at “L”)
43	ADDC	I	Connected to the external capacitor for cutting the low band of the ADIP amplifier
44	OPO	O	User operational amplifier output terminal Not used (open)
45	OPN	I	User operational amplifier inversion input terminal Not used (fixed at “L”)
46	RFO	O	RF signal output terminal
47	MORFI	I	Receives a MO RF signal in AC coupling
48	MORFO	O	MO RF signal output terminal

● BD BOARD IC121 CXD2650R

(DIGITAL SIGNAL PROCESSOR, DIGITAL SERVO PROCESSOR, EFM/ACIRC ENCODER/DECODER, SHOCK PROOF MEMORY CONTROLLER, ATRAC ENCODER/DECODER, 2M BIT D-RAM)

Pin No.	Pin Name	I/O	Function
1	FOK	O	Focus OK signal output to the system controller (IC401) "H" is output when focus is on
2	SHCK	O	Track jump detection signal output to the system controller (IC401)
3	XBUSY	O	Monitor 2 signal output to the system controller (IC401)
4	SLOC	O	Monitor 3 signal output to the system controller (IC401)
5	SWDT	I	Writing data signal input from the system controller (IC401)
6	SCLK	I	Serial clock signal input from the system controller (IC401)
7	XLAT	I	Serial latch signal input from the system controller (IC401)
8	SRDT	O (3)	Reading data signal output to the system controller (IC401)
9	SENS	O (3)	Internal status (SENSE) output to the system controller (IC401)
10	$\overline{\text{XRST}}$	I	Reset signal input from the system controller (IC401) "L": reset
11	SQSY	O	Subcode Q sync (SCOR) output to the system controller (IC401) "L" is output every 13.3 msec Almost all, "H" is output
12	DQSY	O	Digital In U-bit CD format subcode Q sync (SCOR) output to the system controller (IC401) "L" is output every 13.3 msec Almost all, "H" is output
13	RECP	I	Laser power selection signal input from the system controller (IC401) "H": recording mode, "L": playback mode
14	XINT	O	Interrupt status output to the system controller (IC401)
15	TX	I	Recording data output enable signal input from the system controller (IC401) Writing data transmission timing input (Also serves as the magnetic head on/off output)
16	OSCI	I	System clock signal (512Fs=22.5792 MHz) input from the A/D, D/A converter (IC201)
17	OSCO	O	System clock signal (512Fs=22.5792 MHz) output terminal Not used (open)
18	XTSL	I	Input terminal for the system clock frequency setting "L": 45.1584 MHz, "H": 22.5792 MHz (fixed at "H" in this set)
19	RVDD	—	Power supply terminal (+3.3V) (digital system)
20	RVSS	—	Ground terminal (digital system)
21	DIN	I	Digital audio signal input terminal when recording mode (for optical in)
22	DOUT	O	Digital audio signal output terminal when playback mode (for optical out) Not used
23	ADDT	I	Recording data input from the A/D, D/A converter (IC201)
24	DADT	O	Playback data output to the A/D, D/A converter (IC201)
25	LRCK	O	L/R sampling clock signal (44.1 kHz) output to the A/D, D/A converter (IC201)
26	XBCK	O	Bit clock signal (2.8224 MHz) output to the A/D, D/A converter (IC201)
27	FS256	O	Clock signal (11.2896 MHz) output terminal Not used (open)
28	DVDD	—	Power supply terminal (+3.3V) (digital system)
29	A03	O	Address signal output to the external D-RAM Not used (open)
30	A02	O	
31	A01	O	
32	A00	O	
33	A10	O	
34	A04	O	
35	A05	O	
36	A06	O	
37	A07	O	
38	A08	O	
39	A11	O	

Pin No.	Pin Name	I/O	Function
40	DVSS	—	Ground terminal (digital system)
41	$\overline{\text{XOE}}$	O	Output enable signal output to the external D-RAM Not used (open)
42	$\overline{\text{XCAS}}$	O	Column address strobe signal output to the external D-RAM Not used (open)
43	A09	O	Address signal output to the external D-RAM Not used (open)
44	$\overline{\text{XRAS}}$	O	Row address strobe signal output to the external D-RAM Not used (open)
45	$\overline{\text{XWE}}$	O	Write enable signal output to the external D-RAM Not used (open)
46	D1	I/O	Two-way data bus for the external D-RAM Not used (open)
47	D0	I/O	
48	D2	I/O	
49	D3	I/O	
50	MVCI	I	Digital in PLL oscillation input from the external VCO Not used (fixed at "L")
51	ASYO	O	Playback EFM full-swing output
52	ASYI	I (A)	Playback EFM asymmetry comparator voltage input
53	AVDD	—	Power supply terminal (+3.3V) (analog system)
54	BIAS	I (A)	Playback EFM asymmetry circuit constant current input
55	RFI	I (A)	Playback EFM RF signal input from the CXA2523R (IC101)
56	AVSS	—	Ground terminal (analog system)
57	PDO	O (3)	Phase comparison output for clock playback analog PLL of the playback EFM Not used (open)
58	PCO	O (3)	Phase comparison output for master clock of the recording/playback EFM master PLL
59	FILI	I (A)	Filter input for master clock of the recording/playback master PLL
60	FILO	O (A)	Filter output for master clock of the recording/playback master PLL
61	CLTV	I (A)	Internal VCO control voltage input of the recording/playback master PLL
62	PEAK	I (A)	Light amount signal (RF/ABCD) peak hold input from the CXA2523R (IC101)
63	BOTM	I (A)	Light amount signal (RF/ABCD) bottom hold input from the CXA2523R (IC101)
64	ABCD	I (A)	Light amount signal (ABCD) input from the CXA2523R (IC101)
65	FE	I (A)	Focus error signal input from the CXA2523R (IC101)
66	AUX1	I (A)	Auxiliary signal (I ₃ signal/temperature signal) input from the CXA2523R (IC101)
67	VC	I (A)	Middle point voltage (+1.65V) input from the CXA2523R (IC101)
68	ADIO	O (A)	Monitor output of the A/D converter input signal Not used (open)
69	AVDD	—	Power supply terminal (+3.3V) (analog system)
70	ADRT	I (A)	A/D converter operational range upper limit voltage input terminal (fixed at "H" in this set)
71	ADRB	I (A)	A/D converter operational range lower limit voltage input terminal (fixed at "L" in this set)
72	AVSS	—	Ground terminal (analog system)
73	SE	I (A)	Sled error signal input from the CXA2523R (IC101)
74	TE	I (A)	Tracking error signal input from the CXA2523R (IC101)
75	AUX2	I (A)	Auxiliary signal input terminal Not used (fixed at "L")
76	DCHG	I (A)	Connected to the +3.3V power supply
77	APC	I (A)	Error signal input for the laser automatic power control Not used (fixed at "L")
78	ADFG	I	ADIP duplex FM signal (22.05 kHz \pm 1 kHz) input from the CXA2523R (IC101)
79	F0CNT	O	Filter f0 control signal output to the CXA2523R (IC101)
80	XLRF	O	Serial latch signal output to the CXA2523R (IC101)
81	CKRF	O	Serial clock signal output to the CXA2523R (IC101)
82	DTRF	O	Writing data output to the CXA2523R (IC101)
83	APCREF	O	Control signal output to the reference voltage generator circuit for the laser automatic power control
84	LDDR	O	PWM signal output for the laser automatic power control Not used (open)

Pin No.	Pin Name	I/O	Function
85	TRDR	O	Tracking servo drive PWM signal (-) output to the BH6511FS (IC152)
86	TFDR	O	Tracking servo drive PWM signal (+) output to the BH6511FS (IC152)
87	DVDD	—	Power supply terminal (+3.3V) (digital system)
88	FFDR	O	Focus servo drive PWM signal (+) output to the BH6511FS (IC152)
89	FRDR	O	Focus servo drive PWM signal (-) output to the BH6511FS (IC152)
90	FS4	O	Clock signal (176.4 kHz) output terminal (X'tal system) Not used (open)
91	SRDR	O	Sled servo drive PWM signal (-) output to the BH6511FS (IC152)
92	SFDR	O	Sled servo drive PWM signal (+) output to the BH6511FS (IC152)
93	SPRD	O	Spindle servo drive PWM signal (-) output to the BH6511FS (IC152)
94	SPFD	O	Spindle servo drive PWM signal (+) output to the BH6511FS (IC152)
95	TEST0	I	Input terminal for the test (fixed at "L")
96	TEST1	I	
97	TEST2	I	
98	TEST3	I	
99	DVSS	—	Ground terminal (digital system)
100	EFMO	O	EFM signal output terminal when recording mode

* I (A) for analog input, O (3) for 3-state output, and O (A) for analog output in the column I/O.

● MAIN BOARD IC201 CXD8607N (A/D, D/A CONVERTER)

Pin No.	Pin Name	I/O	Function
1	INRP	I	R-ch analog signal (+) input terminal
2	INRM	I	R-ch analog signal (-) input terminal
3	REFI	I	Reference voltage (+3.3V) input terminal (for A/D converter section)
4	AVDD	—	Power supply terminal (+5V) (for A/D converter section, analog system)
5	AVSS	—	Ground terminal (for A/D converter section, analog system)
6	APD	I	Power down detection input of the A/D converter section (for analog section) “L”: power down
7	NU	—	Not used (open)
8	NU	—	Not used (open)
9	TEST1	I	Input terminal for the test (fixed at “L”)
10	LRCK1	I	L/R sampling clock signal (44.1 kHz) input from the CXD2650R (IC121) (for A/D converter section)
11	BCK1	I	Bit clock signal (2.8224 MHz) input from the CXD2650R (IC121) (for A/D converter section)
12	ADDT	O	Recording data output terminal
13	V35A	—	Power supply terminal (+3.3V) (for analog system)
14	VSS1	—	Ground terminal (for A/D converter section, digital system)
15	MCKI	I	Master clock (256Fs=11.2896 MHz) input of the A/D converter section
16	$\overline{\text{DPD}}$	I	Reset signal input from the system controller (IC401) Reset signal is used as a detection signal of power down to A/D converter section (digital section) “L”: reset (power down)
17	VSS2	—	Ground terminal (for D/A converter section, digital system)
18	$\overline{\text{RES}}$	I	Reset signal input from the system controller (IC401) Reset signal is used as a initialize signal to D/A converter section “L”: reset (initialize)
19	MODE	I	Writing data input from the system controller (IC401)
20	SHIFT	I	Serial clock signal input from the system controller (IC401)
21	XLATCH	I	Serial latch signal input from the system controller (IC401)
22	256CK	O	256Fs (11.2896 MHz) clock signal output terminal
23	V35D	—	Power supply terminal (+3.3V) (for digital system)
24	VSS2	—	Ground terminal (for D/A converter section, digital system)
25	512FS	O	512Fs (22.5792 MHz) clock signal output to the CXD2650R (IC121)
26	BCK2	I	Bit clock signal (2.8224 MHz) input from the CXD2650R (IC121) (for D/A converter section)
27	DADT	I	Playback data input terminal
28	LRCK2	I	L/R sampling clock signal (44.1 kHz) input from the CXD2650R (IC121) (for D/A converter section)
29	VDD2	—	Power supply terminal (+5V) (for D/A converter section, digital system)
30	R1	O	R-ch PLM signal 1 output terminal
31	AVDDR	—	Power supply terminal (+5V) (for R-ch side D/A converter section, analog system)
32	R2	O	R-ch PLM signal 2 output terminal
33	AVSSR	—	Ground terminal (for R-ch side D/A converter section, analog system)
34	XVDD	—	Power supply terminal (+5V) (for X'tal system)
35	XOUT	O	System clock output terminal (22 MHz)
36	XIN	I	System clock input terminal (22 MHz)
37	XVSS	—	Ground terminal (for X'tal system)
38	AVSSL	—	Ground terminal (for L-ch side D/A converter section, analog system)
39	L2	O	L-ch PLM signal 2 output terminal
40	AVDDL	—	Power supply terminal (+5V) (for L-ch side D/A converter section, analog system)
41	L1	O	L-ch PLM signal 1 output terminal
42	VDD2	—	Power supply terminal (+5V) (for L-ch side D/A converter section, digital system)

Pin No.	Pin Name	I/O	Function
42	VDD2	—	Power supply terminal (+5V) (for L-ch side D/A converter section, digital system)
43	VDD1	—	Power supply terminal (+5V) (for A/D converter section, digital system)
44	VDD1	—	Power supply terminal (+5V) (for A/D converter section, digital system)
45	VSS1	—	Ground terminal (for A/D converter section, digital system)
46	TEST2	I	Input terminal for the test (fixed at “L”)
47	TEST3	I	Input terminal for the test (fixed at “L”)
48	VSS1	—	Ground terminal (for A/D converter section, digital system)
49	NU	—	Not used (open)
50	NU	—	Not used (open)
51	AVSS	—	Ground terminal (for A/D converter section, analog system)
52	LVDD	—	Power supply terminal (+5V) (for A/D converter section, buffer system)
53	LVSS	—	Ground terminal (for A/D converter section, buffer system)
54	REFO	O	Reference voltage (+3.3V) output terminal (for A/D converter section)
55	INLM	I	L-ch analog signal (–) input terminal
56	INLP	I	L-ch analog signal (+) input terminal

● MAIN BOARD IC401 RU8X12MF-0010 (SYSTEM CONTROLLER)

Pin No.	Pin Name	I/O	Function
1	DAOUT0	O	Output terminal for the test C1 is output when test mode
2	DAOUT1	O	Output terminal for the test ADER is output when test mode
3	KEY0	I	Key input terminal (A/D input) ▷◀, ▶▶, ◀◀, ■, ENTER/YES, EDIT/NO keys input (S701 to S706)
4	KEY1	I	Key input terminal (A/D input) ≡ EJECT, PROGRAM, SHUFFLE, CONTINUE keys input (S711 to S714)
5	KEY2	I	Key input terminal (A/D input) SCROLL, DISPLAY/CHARACTER, REPEAT, CD SYNC, ● REC keys input (S722 to S726)
6	CHACK-IN	I	Detection input from the disc chucking-in detect switch (S685) "L": chucking
7	PACK-IN	I	Detection input from the disc detect switch Not used (fixed at "H")
8	PACK-OUT	I	Detection input from the loading-out detect switch (S686) "L" at a load-out position, others: "H"
9	TIMER	I	Power switch (S408) input (for service)
10	NC	I	Not used (fixed at "L")
11	AVSS	—	Ground terminal
12	XINT	I	Interrupt status input from the CXD2650R (IC121)
13	PDOWN	I	Power down detection signal input from the regulated power supply IC (IC501) "L": power down, normally: "H"
14	NC	—	Not used (connected to AUBK (pin ⑨) in this set)
15	SQSY	I	Subcode Q sync (SCOR) input from the CXD2650R (IC121) "L" is input every 13.3 msec Almost all, "H" is input
16	DQSY	I	Digital In U-bit CD format subcode Q sync (SCOR) input from the CXD2650R (IC121) "L" is input every 13.3 msec Almost all, "H" is input
17	NC	—	Not used (open)
18	NC	—	
19	NC	—	
20	<u>SYS-RST</u>	I	System reset signal input from the regulated power supply IC (IC501) "L": reset For several hundreds msec. after the power supply rises, "L" is input, then it changes to "H"
21	TEST	I	Input terminal for the test Fixed at "L" in this set
22	+3.3V	—	Power supply terminal (+3.3V)
23	BACK	I	Power supply terminal for the backup (for internal RAM)
24	XOUT-T	O	Sub system clock output terminal (32.768 kHz)
25	XIN-T	I	Sub system clock input terminal (32.768 kHz)
26	GND	—	Ground terminal
27	XOUT	O	Main system clock output terminal (12 MHz)
28	XIN	I	Main system clock input terminal (12 MHz)
29	GND	—	Ground terminal
30	S1	O	System clock output terminal Not used (open)
31	DOSEL	O	Not used (open)
32	SENS	I	Internal status (SENSE) input from the CXD2650R (IC121)
33	SHOCK	I	Track jump detection signal input from the CXD2650R (IC121)
34	NC	—	Not used (open)
35	CD/VIDEO	O	Selection signal output terminal for the optical-in signal (CD/VIDEO) "L": CD, "H": VIDEO
36	STB	O	Strobe signal output to the regulated power supply IC (IC501) "H": power on, "L": standby mode
37	REC-P	I	Detection input from the recording position detect switch (S688) "L" active
38	PB-P	I	Detection input from the playback position detect switch (S687) "L" active

Pin No.	Pin Name	I/O	Function
39	LD LOW	O	Loading motor voltage control signal output to the loading motor driver (IC311)
40	NC	—	Not used (open)
41	MNT2	I	Monitor 2 signal input from the CXD2650R (IC121)
42	MNT3	I	Monitor 3 signal input from the CXD2650R (IC121)
43	LED0	O	LED drive signal output terminal Not used (open)
44	NC	—	Not used (open)
45	NC	—	Not used (open)
46	BUS-OUT	O	Audio bus signal output terminal
47	GND	—	Ground terminal
48	+3.3V	—	Power supply terminal (+3.3V)
49	NC	—	Not used (open)
50	JOG1	I	JOG dial pulse input of the rotary encoder (S741)
51	JOG0	I	JOG dial pulse input of the rotary encoder (S741)
52	SDA	IO	Two-way data bus for the EEPROM (IC171)
53	SCL	O	Clock signal output to the EEPROM (IC171)
54	FS32	O	LED drive signal output terminal of the 32 kHz indication LED (D734) “L”: LED on
55	FS44	O	LED drive signal output terminal of the 44.1 kHz indication LED (D735) “L”: LED on
56	FS48	O	LED drive signal output terminal of the 48 kHz indication LED (D736) “L”: LED on
57	NC	—	Not used (open)
58	NC	—	Not used (open)
59	AUBK	I	Check signal input of the audio bus connection
60	SA/SW	O	Selection signal output terminal of the audio bus and remote controller Not used (open)
61	AIN	O	LED drive signal output terminal of the ANALOG IN indication LED (D733) “L”: LED on
62	NC	—	Not used (open)
63	CLKSET0	I	Clock destination selected terminal (fixed at “H” in this set)
64	CLKSET1	I	Clock destination selected terminal (fixed at “L” in this set)
65	GND	—	Ground terminal
66	+3.3V	—	Power supply terminal (+3.3V)
67	SCLK	O	Serial clock signal output to the CXD2650R (IC121) and A/D, D/A converter (IC201)
68	SWDT	O	Writing data output to the CXD2650R (IC121) and A/D, D/A converter (IC201)
69	SRDT	I	Reading data input from the CXD2650R (IC121)
70	NC	—	Not used (open)
71	FLCLK	O	Serial data transfer clock signal output to the fluorescent indicator tube driver (IC701)
72	FLDATA	O	Serial data output to the fluorescent indicator tube driver (IC701)
73	FLCS	O	Chip select signal output to the fluorescent indicator tube driver (IC701)
74	NC	—	Not used (open)
75	LDON	O	Laser diode on/off control signal output to the automatic power control circuit “H”: laser on
76	PIT/GRV	O	Pit/groove detection signal output terminal “H” is output for the playback only disc or TOC area Not used (open)
77	FOK	I	Focus OK signal input from the CXD2650R (IC121) “H” is input when focus is on
78	NC	—	Not used (open)
79	LOCK	O	Lock signal output terminal Not used (open)
80	WRPWR	O	Laser power select signal output to the CXD2650R (IC121) “H”: recording mode, “L”: playback mode
81	DIG-RST	O	Reset signal output to the CXD2650R (IC121) and BH6511FS (IC152) “L”: reset

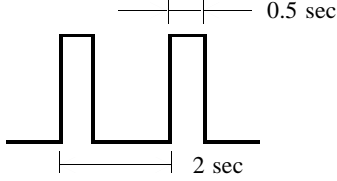
Pin No.	Pin Name	I/O	Function
82	BEEP	O	Beep sound drive signal output terminal Not used (open)
83	ADARES	O	Reset signal output to the A/D, D/A converter (IC201) "L": reset
84	SWL-A	O	Not used (open)
85	SEL-B	O	Not used (open)
86	MOD	O	Laser modulation select signal output Playback power: "L", Stop: "H", Recording power: 
87	REC/PB	O	Not used (open)
88	NC	—	Not used (open)
89	SCTX	O	Recording data output enable signal output to the CXD2650R (IC121) Writing data transmission timing output (Also serves as the magnetic head on/off output)
90	XLATCH	O	Serial latch signal output to the CXD2650R (IC121) and A/D, D/A converter (IC201)
91	NC	—	Not used (open)
92	NC	—	Not used (open)
93	MUTE	O	Line mute control signal output to the CXA8065S (IC101)
94	LDOUT	O	Motor control signal output to the loading motor driver (IC311) *1
95	LDIN	O	Motor control signal output to the loading motor driver (IC311) *1
96	LIMIT-IN	I	Detection input from the sled limit-in detect switch (S681) The optical pick-up is inner position when "L"
97	PROTECT	I	Rec-proof claw detect input from the protect detect switch (S683) "H": write protect
98	REFLECT	I	Detection input from the disc reflection rate detect switch (S682) "L": high reflection rate disc, "H": low reflection rate disc
99	GND	—	Ground terminal
100	+3.3V	—	Power supply terminal (+3.3V)

*1 Loading Motor Control

Operation Terminal	IN	OUT	BRAKE	RUN IDLE
LDIN (pin ⑨)	"H"	"L"	"H"	"L"
LDOUT (pin ⑩)	"L"	"H"	"H"	"L"

SECTION 7 EXPLODED VIEWS

NOTE:

- -XX and -X mean standardized parts, so they may have some difference from the original one.
- Color Indication of Appearance Parts Example:
 KNOB, BALANCE (WHITE) . . . (RED)
 ↑ ↑
 Parts Color Cabinet's Color
- Items marked "*" are not stocked since they are seldom required for routine service. Some delay should be anticipated when ordering these items.
- The mechanical parts with no reference number in the exploded views are not supplied.
- Hardware (# mark) list is given in the last of the electrical parts list.

The components identified by mark \triangle or dotted line with mark \triangle are critical for safety. Replace only with part number specified.

(1) CHASSIS SECTION

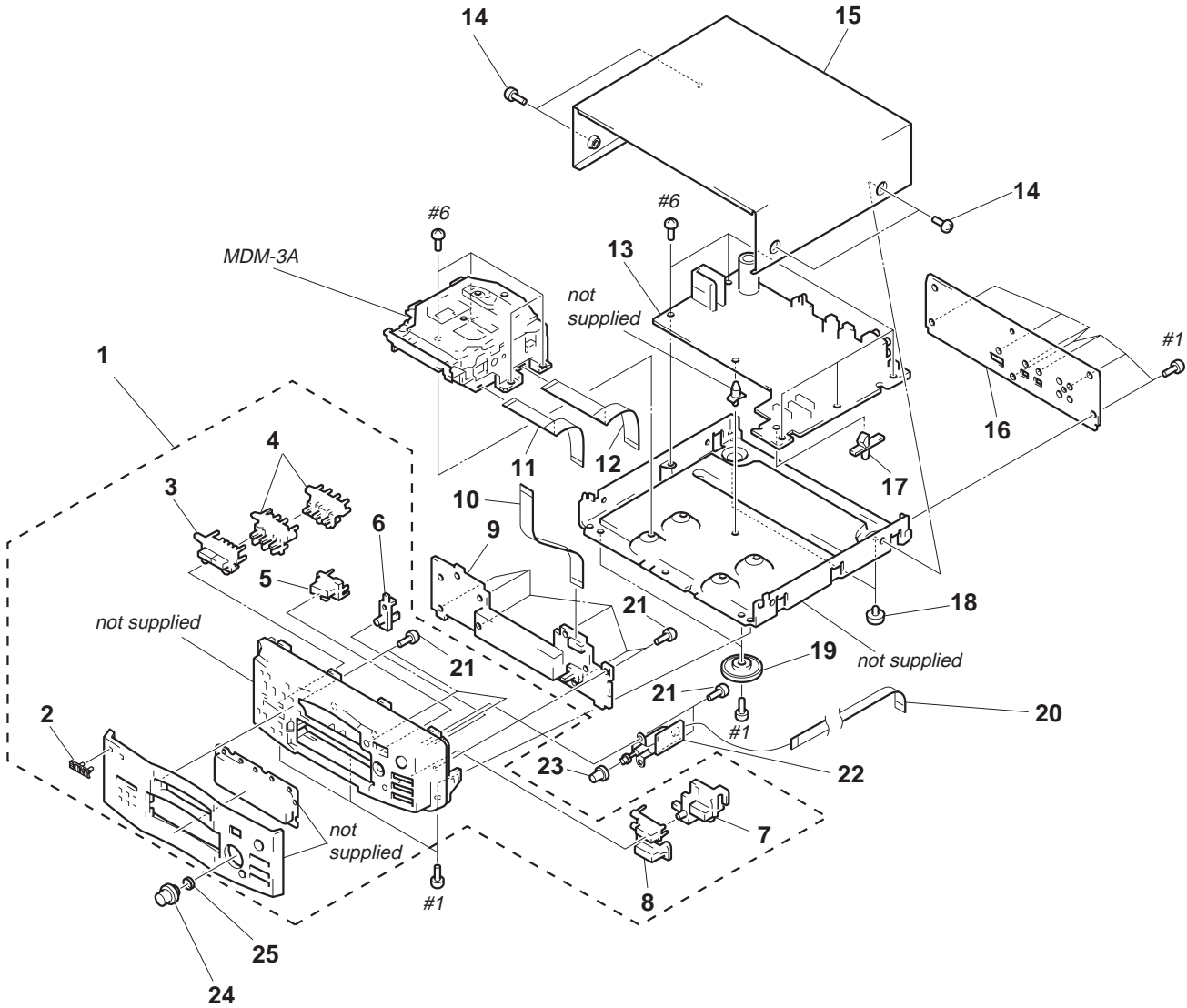

Ref. No.	Part No.	Description	Remark	Ref. No.	Part No.	Description	Remark
1	X-4947-652-1	PANEL ASSY, FRONT		14	3-363-099-01	SCREW (CASE 3 TP2)	
2	4-962-708-01	EMBLEM (4-A), SONY		* 15	4-985-899-11	CASE	
3	4-985-889-01	BUTTON (REC) (CD SYNC, ● REC)		* 16	4-985-898-12	PANEL (MDS), BACK	
4	4-985-890-01	BUTTON (MODE)		* 17	3-350-847-21	HOLDER, PCB	
5	4-985-891-01	BUTTON (EJECT) (≡ EJECT)		18	4-965-822-01	FOOT	
6	4-985-894-01	BUTTON (EDIT)		19	4-977-699-11	LEG (F)	
7	X-4947-763-1	BUTTON (F/R) ASSY (◀▶)		20	1-777-473-11	WIRE (FLAT TYPE) (5 CORE)	
8	4-985-892-01	BUTTON (PLAY) (▶⏪, ■)		21	4-951-620-01	SCREW (2.6X8), +BVTP	
* 9	A-4699-657-A	PANEL BOARD, COMPLETE		* 22	1-663-192-11	REC VOL BOARD	
10	1-777-654-11	WIRE (FLAT TYPE) (19 CORE)		23	4-985-896-01	KNOB (REC)	
11	1-777-558-11	WIRE (FLAT TYPE) (19 CORE)		24	4-985-925-01	KNOB (JOG)	
12	1-777-559-11	WIRE (FLAT TYPE) (29 CORE)		25	4-988-161-01	SPRING, RING	
* 13	A-4699-656-A	MAIN BOARD, COMPLETE					

**(2) MECHANISM DECK SECTION-1
(MDM-3A)**

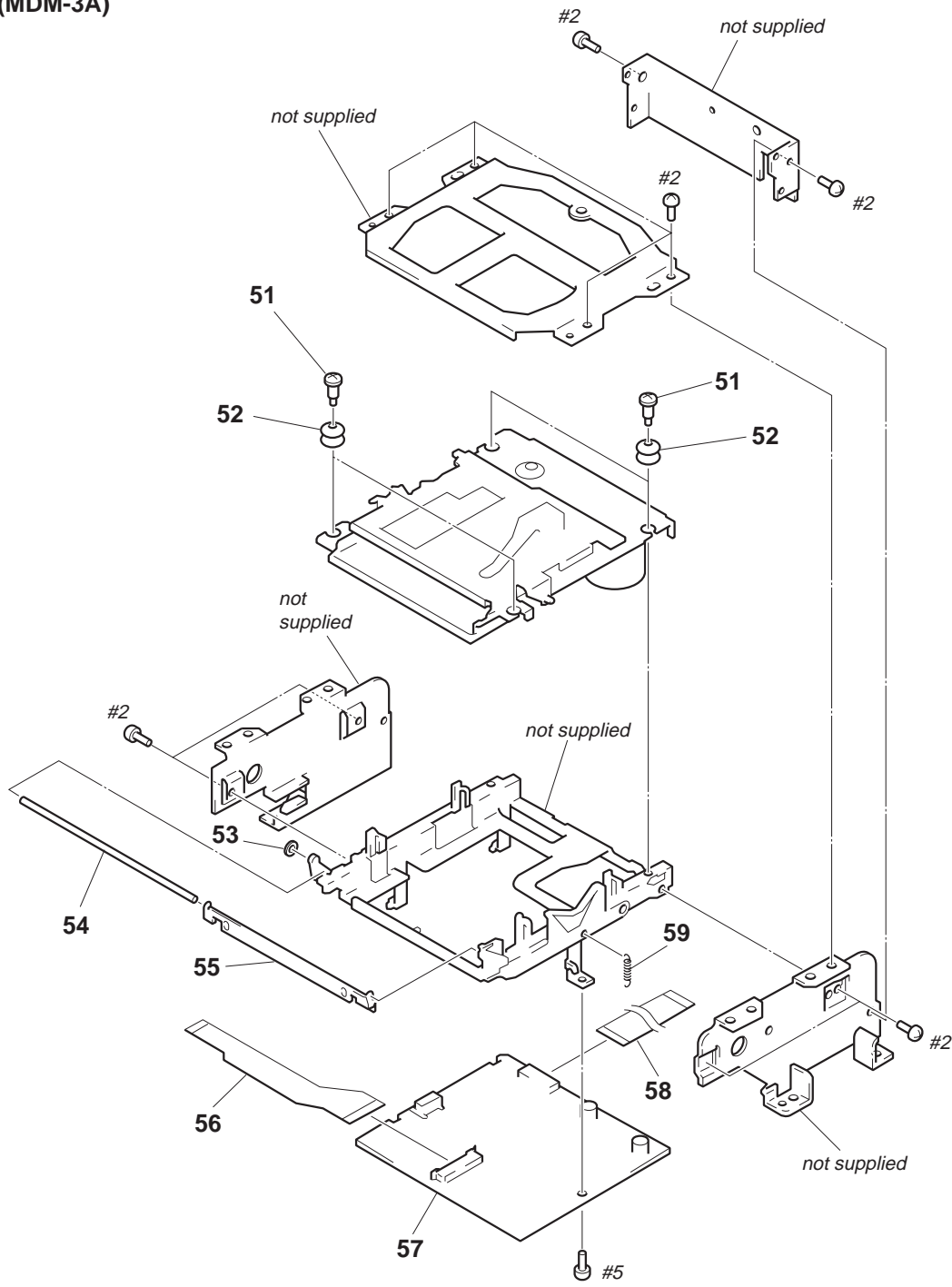

Ref. No.	Part No.	Description	Remark	Ref. No.	Part No.	Description	Remark
51	4-628-167-01	SCREW, STEP		56	1-660-966-11	OP RELAY FLEXIBLE BOARD	
52	4-987-327-01	INSULATOR		* 57	A-4699-092-A	BD BOARD, COMPLETE	
53	4-986-959-01	WASHER, STOPPER		58	1-777-517-11	WIRE (FLAT TYPE) (15 CORE)	
54	4-987-736-01	SHAFT (SHUTTER)		59	4-987-910-01	SPRING (O/C), TENSION	
55	X-4947-825-1	SHUTTER ASSY					

**(3) MECHANISM DECK SECTION-2
(MDM-3A)**

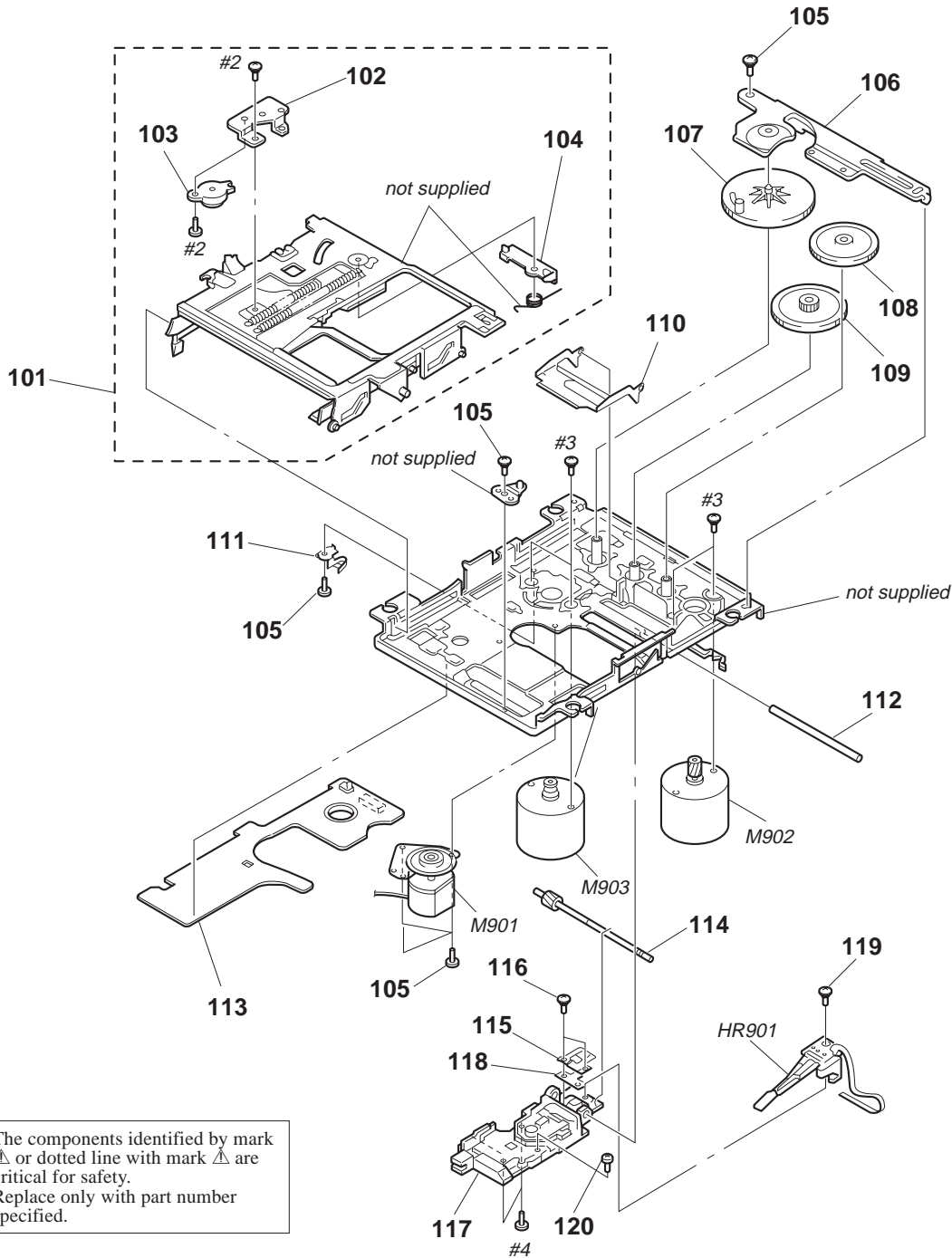

The components identified by mark \triangle or dotted line with mark \triangle are critical for safety. Replace only with part number specified.

Ref. No.	Part No.	Description	Remark	Ref. No.	Part No.	Description	Remark
101	A-4672-138-A	SLIDER COMPLETE ASSY		* 113	1-661-774-11	SW BOARD	
* 102	4-983-439-01	BRACKET (DAMPER)		114	A-3304-200-A	SCREW ASSY, LEAD	
103	3-953-235-01	DAMPER, OIL		115	4-963-914-02	RACK (INSERTER)	
* 104	4-983-437-01	SLIDER (CAM)		116	3-366-890-11	SCREW (M1.4)	
105	3-342-375-11	SCREW (M1.7X1.4), SPECIAL		i 117	8-583-028-02	OPTICAL PICK-UP KMS-260A/J1N	
106	4-979-890-11	RETAINER (GEAR)		118	4-987-061-01	SPACER (RACK)	
107	4-979-898-01	GEAR (LB)		119	4-988-560-01	SCREW (+P 1.7X6)	
108	4-979-899-01	GEAR (LC)		120	4-955-841-11	SCREW	
109	4-979-897-01	GEAR (LA)		HR901	1-500-396-11	HEAD, OVER WRITE	
110	4-979-885-01	LEVER (HEAD UP)		M901	A-4672-135-A	MOTOR ASSY, SPINDLE	
111	4-979-906-11	SPRING (LEAD SCREW)		M902	A-4672-133-A	MOTOR ASSY, SLED	
112	4-984-556-01	SHAFT (MAIN SHAFT)		M903	A-4672-134-A	MOTOR ASSY, LOADING	

SECTION 8 ELECTRICAL PARTS LIST

BD

NOTE:

- Due to standardization, replacements in the parts list may be different from the parts specified in the diagrams or the components used on the set.
- -XX and -X mean standardized parts, so they may have some difference from the original one.
- RESISTORS
All resistors are in ohms.
METAL: Metal-film resistor.
METAL OXIDE: Metal oxide-film resistor.
F: nonflammable

- Items marked “*” are not stocked since they are seldom required for routine service.
Some delay should be anticipated when ordering these items.
- SEMICONDUCTORS
In each case, u: μ , for example:
uA. . . : μ A. . . uPA. . . : μ PA. . .
uPB. . . : μ PB. . . uPC. . . : μ PC. . .
uPD. . . : μ PD. . .
- CAPACITORS
uF: μ F
- COILS
uH: μ H

The components identified by mark Δ or dotted line with mark Δ are critical for safety.
Replace only with part number specified.

When indicating parts by reference number, please include the board.

Ref. No.	Part No.	Description	Remark	Ref. No.	Part No.	Description	Remark
*	A-4699-092-A	BD BOARD, COMPLETE *****		C158	1-163-019-00	CERAMIC CHIP 0.0068uF 10%	50V
		< CAPACITOR >		C160	1-104-601-11	ELECT CHIP 10uF 20%	10V
C101	1-104-851-11	TANTAL. CHIP 10uF	20% 10V	C161	1-104-601-11	ELECT CHIP 10uF 20%	10V
C102	1-163-038-00	CERAMIC CHIP 0.1uF	25V	C163	1-164-232-11	CERAMIC CHIP 0.01uF	50V
C103	1-104-851-11	TANTAL. CHIP 10uF	20% 10V	C164	1-164-232-11	CERAMIC CHIP 0.01uF	50V
C104	1-104-851-11	TANTAL. CHIP 10uF	20% 10V	C167	1-163-038-00	CERAMIC CHIP 0.1uF	25V
C105	1-164-232-11	CERAMIC CHIP 0.01uF	50V	C168	1-163-038-00	CERAMIC CHIP 0.1uF	25V
C106	1-163-275-11	CERAMIC CHIP 0.001uF	5% 50V	C169	1-104-851-11	TANTAL. CHIP 10uF	20% 10V
C107	1-163-038-00	CERAMIC CHIP 0.1uF	25V	C171	1-163-038-00	CERAMIC CHIP 0.1uF	25V
C108	1-163-038-00	CERAMIC CHIP 0.1uF	25V	C181	1-126-206-11	ELECT CHIP 100uF	20% 6.3V
C109	1-163-037-11	CERAMIC CHIP 0.022uF	10% 25V	C182	1-163-038-00	CERAMIC CHIP 0.1uF	25V
C110	1-163-038-00	CERAMIC CHIP 0.1uF	25V	C183	1-163-038-00	CERAMIC CHIP 0.1uF	25V
C111	1-164-344-11	CERAMIC CHIP 0.068uF	10% 25V	C184	1-107-836-11	ELECT CHIP 22uF	20% 8V
C112	1-163-017-00	CERAMIC CHIP 0.0047uF	5% 50V	C185	1-164-611-11	CERAMIC CHIP 0.001uF	10% 500V
C113	1-107-682-11	CERAMIC CHIP 1uF	10% 16V	C187	1-126-206-11	ELECT CHIP 100uF	20% 6.3V
C115	1-164-489-11	CERAMIC CHIP 0.22uF	10% 16V	C188	1-164-232-11	CERAMIC CHIP 0.01uF	50V
C116	1-163-037-11	CERAMIC CHIP 0.022uF	10% 25V	C189	1-163-989-11	CERAMIC CHIP 0.033uF	10% 25V
C117	1-164-004-11	CERAMIC CHIP 0.1uF	10% 25V	C190	1-126-206-11	ELECT CHIP 100uF	20% 6.3V
C119	1-104-851-11	TANTAL. CHIP 10uF	20% 10V	C191	1-163-038-00	CERAMIC CHIP 0.1uF	25V
C121	1-126-206-11	ELECT CHIP 100uF	20% 6.3V	C195	1-164-346-11	CERAMIC CHIP 1uF	16V
C122	1-164-232-11	CERAMIC CHIP 0.01uF	50V	C196	1-163-038-00	CERAMIC CHIP 0.1uF	25V
C123	1-163-038-00	CERAMIC CHIP 0.1uF	25V	C197	1-163-038-00	CERAMIC CHIP 0.1uF	25V
C124	1-163-038-00	CERAMIC CHIP 0.1uF	25V			< CONNECTOR >	
C127	1-163-038-00	CERAMIC CHIP 0.1uF	25V	CN101	1-766-508-11	CONNECTOR, FFC/FPC (ZIF) 22P	
C128	1-164-232-11	CERAMIC CHIP 0.01uF	50V	CN102	1-778-461-11	CONNECTOR, FFC/FPC 29P	
C129	1-107-823-11	CERAMIC CHIP 0.47uF	10% 16V	CN103	1-778-460-11	CONNECTOR, FFC/FPC 19P	
C130	1-163-251-11	CERAMIC CHIP 100PF	5% 50V	CN104	1-766-898-21	HOUSING, CONNECTOR (PC BOARD) 4P	
C131	1-163-023-00	CERAMIC CHIP 0.015uF	5% 50V	CN106	1-770-698-11	CONNECTOR, FFC/FPC 15P	
C132	1-107-823-11	CERAMIC CHIP 0.47uF	10% 16V	CN110	1-774-731-21	PIN, CONNECTOR (PC BOARD) 5P	
C133	1-163-017-00	CERAMIC CHIP 0.0047uF	5% 50V			< DIODE >	
C134	1-163-038-00	CERAMIC CHIP 0.1uF	25V	D101	8-719-988-62	DIODE 1SS355	
C135	1-163-038-00	CERAMIC CHIP 0.1uF	25V	D181	8-719-046-86	DIODE F1J6TP	
C136	1-126-206-11	ELECT CHIP 100uF	20% 6.3V	D183	8-719-046-86	DIODE F1J6TP	
C141	1-163-038-00	CERAMIC CHIP 0.1uF	25V			< IC/TRANSISTOR >	
C142	1-163-251-11	CERAMIC CHIP 100PF	5% 50V	IC101	8-752-074-77	IC CXA2523R	
C143	1-163-251-11	CERAMIC CHIP 100PF	5% 50V	IC103	8-729-903-10	TRANSISTOR FMW1	
C144	1-163-251-11	CERAMIC CHIP 100PF	5% 50V	IC121	8-752-378-54	IC CXD2650R	
C146	1-163-038-00	CERAMIC CHIP 0.1uF	25V	IC122	8-759-234-20	IC TC7S08F	
C151	1-126-206-11	ELECT CHIP 100uF	20% 6.3V	IC123	8-759-242-70	IC TC7WU04F	
C152	1-163-038-00	CERAMIC CHIP 0.1uF	25V	IC152	8-759-430-25	IC BH6511FS-E2	
C153	1-164-232-11	CERAMIC CHIP 0.01uF	50V				
C156	1-163-038-00	CERAMIC CHIP 0.1uF	25V				

Ref. No.	Part No.	Description	Remark
IC171	8-759-428-58	IC XL24C01AF-E2	
IC181	8-759-095-65	IC TC74ACT540FS	
IC192	8-759-426-95	IC L88MS33T-TL	
< COIL/FERRITE BEAD >			
L101	1-414-235-11	INDUCTOR, FERRITE BEAD	
L102	1-414-235-11	INDUCTOR, FERRITE BEAD	
L103	1-414-235-11	INDUCTOR, FERRITE BEAD	
L105	1-414-235-11	INDUCTOR, FERRITE BEAD	
L106	1-414-235-11	INDUCTOR, FERRITE BEAD	
L121	1-414-235-11	INDUCTOR, FERRITE BEAD	
L122	1-414-235-11	INDUCTOR, FERRITE BEAD	
L151	1-412-622-51	INDUCTOR CHIP 10uH	
L152	1-412-622-51	INDUCTOR CHIP 10uH	
L153	1-412-039-51	INDUCTOR CHIP 100uH	
L154	1-412-039-51	INDUCTOR CHIP 100uH	
L161	1-414-235-11	INDUCTOR, FERRITE BEAD	
L162	1-414-235-11	INDUCTOR, FERRITE BEAD	
< TRANSISTOR >			
Q101	8-729-403-35	TRANSISTOR UN5113	
Q102	8-729-026-53	TRANSISTOR 2SA1576A-T106-QR	
Q103	8-729-014-04	TRANSISTOR RN1307-TE85L	
Q104	8-729-014-04	TRANSISTOR RN1307-TE85L	
Q162	8-729-101-07	TRANSISTOR 2SB798-DL	
Q163	8-729-403-35	TRANSISTOR UN5113	
Q180	8-729-907-00	TRANSISTOR DTC114EU	
Q181	8-729-018-75	FET 2SJ278MY	
Q182	8-729-017-65	FET 2SK1764KY	
< RESISTOR/CHIP CONDUCTOR >			
R101	1-216-295-00	CONDUCTOR, CHIP (2012)	
R103	1-216-049-00	METAL CHIP 1K 5% 1/10W	
R104	1-216-073-00	METAL CHIP 10K 5% 1/10W	
R105	1-216-065-00	METAL CHIP 4.7K 5% 1/10W	
R106	1-216-133-00	METAL CHIP 3.3M 5% 1/10W	
R107	1-216-113-00	METAL CHIP 470K 5% 1/10W	
R109	1-216-295-00	CONDUCTOR, CHIP (2012)	
R110	1-216-073-00	METAL CHIP 10K 5% 1/10W	
R111	1-216-295-00	CONDUCTOR, CHIP (2012)	
R112	1-216-089-00	METAL CHIP 47K 5% 1/10W	
R113	1-216-049-00	METAL CHIP 1K 5% 1/10W	
R115	1-216-049-00	METAL CHIP 1K 5% 1/10W	
R117	1-216-113-00	METAL CHIP 470K 5% 1/10W	
R120	1-216-025-00	METAL CHIP 100 5% 1/10W	
R121	1-216-097-00	METAL CHIP 100K 5% 1/10W	
R123	1-216-033-00	METAL CHIP 220 5% 1/10W	
R124	1-216-025-00	METAL CHIP 100 5% 1/10W	
R125	1-216-025-00	METAL CHIP 100 5% 1/10W	
R127	1-216-025-00	METAL CHIP 100 5% 1/10W	
R131	1-216-073-00	METAL CHIP 10K 5% 1/10W	
R132	1-216-097-00	METAL CHIP 100K 5% 1/10W	
R133	1-216-117-00	METAL CHIP 680K 5% 1/10W	
R134	1-216-049-00	METAL CHIP 1K 5% 1/10W	
R135	1-216-061-00	METAL CHIP 3.3K 5% 1/10W	
R136	1-216-049-00	METAL CHIP 1K 5% 1/10W	
R137	1-216-025-00	METAL CHIP 100 5% 1/10W	
R140	1-216-029-00	METAL CHIP 150 5% 1/10W	
R141	1-216-295-00	CONDUCTOR, CHIP (2012)	

Ref. No.	Part No.	Description	Remark
R142	1-216-073-00	METAL CHIP 10K 5% 1/10W	
R143	1-216-073-00	METAL CHIP 10K 5% 1/10W	
R144	1-216-025-00	METAL CHIP 100 5% 1/10W	
R146	1-216-037-00	METAL CHIP 330 5% 1/10W	
R147	1-216-025-00	METAL CHIP 100 5% 1/10W	
R148	1-216-045-00	METAL CHIP 680 5% 1/10W	
R150	1-216-295-00	CONDUCTOR, CHIP (2012)	
R158	1-216-097-00	METAL CHIP 100K 5% 1/10W	
R159	1-216-097-00	METAL CHIP 100K 5% 1/10W	
R161	1-216-057-00	METAL CHIP 2.2K 5% 1/10W	
R162	1-216-057-00	METAL CHIP 2.2K 5% 1/10W	
R163	1-216-057-00	METAL CHIP 2.2K 5% 1/10W	
R164	1-216-045-00	METAL CHIP 680 5% 1/10W	
R165	1-216-097-00	METAL CHIP 100K 5% 1/10W	
R166	1-220-149-11	METAL CHIP 2.2 10% 1/2W	
R167	1-216-065-00	METAL CHIP 4.7K 5% 1/10W	
R169	1-219-724-11	METAL CHIP 1 1% 1/4W	
R170	1-216-073-00	METAL CHIP 10K 5% 1/10W	
R171	1-216-073-00	METAL CHIP 10K 5% 1/10W	
R172	1-216-295-00	CONDUCTOR, CHIP (2012)	
R173	1-216-121-00	METAL CHIP 1M 5% 1/10W	
R175	1-216-061-00	METAL CHIP 3.3K 5% 1/10W	
R176	1-216-295-00	CONDUCTOR, CHIP (2012)	
R177	1-216-061-00	METAL CHIP 3.3K 5% 1/10W	
R178	1-216-295-00	CONDUCTOR, CHIP (2012)	
R179	1-216-089-00	METAL CHIP 47K 5% 1/10W	
R180	1-216-073-00	METAL CHIP 10K 5% 1/10W	
R181	1-216-073-00	METAL CHIP 10K 5% 1/10W	
R182	1-216-089-00	METAL CHIP 47K 5% 1/10W	
R183	1-216-089-00	METAL CHIP 47K 5% 1/10W	
R183	1-216-089-00	METAL CHIP 47K 5% 1/10W	
R184	1-216-073-00	METAL CHIP 10K 5% 1/10W	
R185	1-216-073-00	METAL CHIP 10K 5% 1/10W	
R186	1-216-296-00	CONDUCTOR, CHIP (3216)	
R187	1-216-296-00	CONDUCTOR, CHIP (3216)	
R188	1-216-073-00	METAL CHIP 10K 5% 1/10W	
R189	1-216-073-00	METAL CHIP 10K 5% 1/10W	
R190	1-216-073-00	METAL CHIP 10K 5% 1/10W	
R195	1-216-295-00	CONDUCTOR, CHIP (2012)	
R196	1-216-295-00	CONDUCTOR, CHIP (2012)	
R198	1-216-295-00	CONDUCTOR, CHIP (2012)	
R199	1-216-295-00	CONDUCTOR, CHIP (2012)	
R200	1-216-295-00	CONDUCTOR, CHIP (2012)	
R201	1-216-295-00	CONDUCTOR, CHIP (2012)	
R202	1-216-295-00	CONDUCTOR, CHIP (2012)	
R502	1-216-295-00	CONDUCTOR, CHIP (2012)	
R504	1-216-295-00	CONDUCTOR, CHIP (2012)	

*	A-4699-656-A	MAIN BOARD, COMPLETE	*****
< LITHIUM BATTERY >			
BA501	1-528-739-11	BATTERY, LITHIUM (VL2020 3V)	
< CAPACITOR >			
C001	1-115-364-11	ELECT 22000uF 20% 16V	
C002	1-126-941-11	ELECT 470uF 20% 25V	
C003	1-126-968-11	ELECT 100uF 20% 50V	

Ref. No.	Part No.	Description	Remark			Ref. No.	Part No.	Description	Remark		
C004	1-126-968-11	ELECT	100uF	20%	50V	C372	1-164-159-11	CERAMIC	0.1uF		50V
C005	1-126-968-11	ELECT	100uF	20%	50V	C391	1-164-159-11	CERAMIC	0.1uF		50V
C006	1-126-941-11	ELECT	470uF	20%	25V	C392	1-164-159-11	CERAMIC	0.1uF		50V
C007	1-128-576-11	ELECT	100uF	20%	63V	C393	1-164-159-11	CERAMIC	0.1uF		50V
C009	1-128-576-11	ELECT	100uF	20%	63V	C396	1-126-916-11	ELECT	1000uF	20%	6.3V
C012	1-164-159-11	CERAMIC	0.1uF		50V	C397	1-126-935-11	ELECT	470uF	20%	6.3V
C019	1-164-159-11	CERAMIC	0.1uF		50V	C400	1-126-935-11	ELECT	470uF	20%	6.3V
C98	1-162-306-11	CERAMIC	0.01uF	20%	16V	C413	1-162-306-11	CERAMIC	0.01uF	20%	16V
C99	1-162-195-31	CERAMIC	4.7PF	10%	50V	C420	1-162-294-31	CERAMIC	0.001uF	10%	50V
C101	1-126-059-11	ELECT	10uF	20%	50V	C422	1-164-159-11	CERAMIC	0.1uF		50V
C103	1-126-059-11	ELECT	10uF	20%	50V	C424	1-162-203-31	CERAMIC	15PF	5%	50V
C106	1-164-159-11	CERAMIC	0.1uF		50V	C425	1-162-203-31	CERAMIC	15PF	5%	50V
C107	1-162-211-31	CERAMIC	33PF	5%	50V	C432	1-162-282-31	CERAMIC	100PF	10%	50V
C108	1-162-211-31	CERAMIC	33PF	5%	50V	C433	1-162-282-31	CERAMIC	100PF	10%	50V
C109	1-126-933-11	ELECT	100uF	20%	10V	C448	1-164-159-11	CERAMIC	0.1uF		50V
C110	1-162-294-31	CERAMIC	0.001uF	10%	50V	C459	1-162-290-31	CERAMIC	470PF	10%	50V
C111	1-162-600-11	CERAMIC	0.0047uF	30%	16V	C467	1-162-282-31	CERAMIC	100PF	10%	50V
C113	1-162-600-11	CERAMIC	0.0047uF	30%	16V	C468	1-162-282-31	CERAMIC	100PF	10%	50V
C114	1-162-294-31	CERAMIC	0.001uF	10%	50V	C490	1-162-282-31	CERAMIC	100PF	10%	50V
C115	1-126-933-11	ELECT	100uF	20%	10V	C500	1-164-159-11	CERAMIC	0.1uF		50V
C116	1-162-211-31	CERAMIC	33PF	5%	50V	C501	1-126-935-11	ELECT	470uF	20%	6.3V
C117	1-162-211-31	CERAMIC	33PF	5%	50V	C503	1-126-964-11	ELECT	10uF	20%	50V
C118	1-162-306-11	CERAMIC	0.01uF	20%	16V	C504	1-126-923-11	ELECT	220uF	20%	10V
C121	1-126-964-11	ELECT	10uF	20%	50V	C505	1-126-935-11	ELECT	470uF	20%	6.3V
C125	1-126-964-11	ELECT	10uF	20%	50V	C506	1-164-159-11	CERAMIC	0.1uF		50V
C128	1-126-933-11	ELECT	100uF	20%	10V	C508	1-126-963-11	ELECT	4.7uF	20%	50V
C130	1-126-964-11	ELECT	10uF	20%	50V	C510	1-126-959-11	ELECT	0.47uF	20%	50V
C134	1-126-964-11	ELECT	10uF	20%	50V	C511	1-131-349-00	TANTALUM	2.2uF	10%	35V
C141	1-162-219-31	CERAMIC	68PF	5%	50V	C513	1-126-964-11	ELECT	10uF	20%	50V
C142	1-162-219-31	CERAMIC	68PF	5%	50V	C514	1-164-159-11	CERAMIC	0.1uF		50V
C200	1-126-012-11	ELECT	470uF	20%	16V	C521	1-126-948-11	ELECT	100uF	20%	35V
C201	1-162-600-11	CERAMIC	0.0047uF	30%	16V	C522	1-126-947-11	ELECT	47uF	20%	35V
C202	1-162-600-11	CERAMIC	0.0047uF	30%	16V	C541	1-126-923-11	ELECT	220uF	20%	10V
C203	1-162-306-11	CERAMIC	0.01uF	20%	16V	C542	1-164-159-11	CERAMIC	0.1uF		50V
C205	1-162-306-11	CERAMIC	0.01uF	20%	16V	C551	1-126-923-11	ELECT	220uF	20%	10V
C223	1-162-306-11	CERAMIC	0.01uF	20%	16V	C552	1-164-159-11	CERAMIC	0.1uF		50V
C231	1-162-306-11	CERAMIC	0.01uF	20%	16V	C5011	1-164-159-11	CERAMIC	0.1uF		50V
C234	1-126-933-11	ELECT	100uF	20%	10V	C5012	1-164-159-11	CERAMIC	0.1uF		50V
C235	1-162-207-31	CERAMIC	22PF	5%	50V	C5014	1-164-159-11	CERAMIC	0.1uF		50V
C236	1-162-203-31	CERAMIC	15PF	5%	50V	C5017	1-164-159-11	CERAMIC	0.1uF		50V
C243	1-164-159-11	CERAMIC	0.1uF		50V	C5037	1-164-159-11	CERAMIC	0.1uF		50V
C254	1-126-923-11	ELECT	220uF	20%	10V	C5103	1-164-159-11	CERAMIC	0.1uF		50V
C255	1-162-600-11	CERAMIC	0.0047uF	30%	16V	C5107	1-164-159-11	CERAMIC	0.1uF		50V
C256	1-162-600-11	CERAMIC	0.0047uF	30%	16V			< CONNECTOR >			
C300	1-126-933-11	ELECT	100uF	20%	10V	CN401	1-770-167-11	CONNECTOR, FFC/FPC 19P			
C301	1-162-306-11	CERAMIC	0.01uF	20%	16V	CN402	1-770-657-11	CONNECTOR, FFC/FPC 29P			
C302	1-162-306-11	CERAMIC	0.01uF	20%	16V	CN501	1-770-158-21	HOUSING, CONNECTOR 7P			
C303	1-162-306-11	CERAMIC	0.01uF	20%	16V			(SYSTEM CONTROL)			
C304	1-162-306-11	CERAMIC	0.01uF	20%	16V	CN700	1-770-167-11	CONNECTOR, FFC/FPC 19P			
C305	1-162-306-11	CERAMIC	0.01uF	20%	16V	* CN800	1-568-824-11	SOCKET, CONNECTOR 5P			
C306	1-162-306-11	CERAMIC	0.01uF	20%	16V			< DIODE >			
C307	1-162-282-31	CERAMIC	100PF	10%	50V	D001	8-719-200-82	DIODE 11ES2			
C308	1-162-282-31	CERAMIC	100PF	10%	50V	D002	8-719-200-82	DIODE 11ES2			
C309	1-164-159-11	CERAMIC	0.1uF		50V	D003	8-719-200-82	DIODE 11ES2			
C310	1-164-159-11	CERAMIC	0.1uF		50V	D004	8-719-200-82	DIODE 11ES2			
C311	1-162-306-11	CERAMIC	0.01uF	20%	16V	D005	8-719-200-82	DIODE 11ES2			
C312	1-162-306-11	CERAMIC	0.01uF	20%	16V	D006	8-719-200-82	DIODE 11ES2			
C314	1-164-159-11	CERAMIC	0.1uF		50V						
C315	1-164-159-11	CERAMIC	0.1uF		50V						

MAIN

Ref. No.	Part No.	Description	Remark	Ref. No.	Part No.	Description	Remark
D008	8-719-200-82	DIODE 11ES2		Q456	8-729-422-57	TRANSISTOR UN4111	
D009	8-719-200-82	DIODE 11ES2		Q461	8-729-422-57	TRANSISTOR UN4111	
D011	8-719-200-82	DIODE 11ES2		Q501	8-729-900-80	TRANSISTOR DTC114ES	
D012	8-719-200-82	DIODE 11ES2		Q502	8-729-422-57	TRANSISTOR UN4111	
D013	8-719-200-82	DIODE 11ES2		Q521	8-729-119-76	TRANSISTOR 2SA1175-HFE	
D014	8-719-200-82	DIODE 11ES2		Q522	8-729-118-01	TRANSISTOR 2SB1116	
D017	8-719-200-82	DIODE 11ES2		< RESISTOR >			
D018	8-719-200-82	DIODE 11ES2		R107	1-249-439-11	CARBON 68K	5% 1/4W
D024	8-719-200-82	DIODE 11ES2		R108	1-249-439-11	CARBON 68K	5% 1/4W
D311	8-719-987-63	DIODE 1N4148M		R109	1-249-429-11	CARBON 10K	5% 1/4W
D351	8-719-987-63	DIODE 1N4148M		R110	1-249-421-11	CARBON 2.2K	5% 1/4W
D521	8-719-002-60	DIODE UZL-33L		R111	1-249-417-11	CARBON 1K	5% 1/4W
D531	8-719-014-66	DIODE UZP-5.6B		R113	1-249-417-11	CARBON 1K	5% 1/4W
< GROUND TERMINAL >				R114	1-249-421-11	CARBON 2.2K	5% 1/4W
EP301	1-537-771-21	TERMINAL BOARD, GROUND		R115	1-249-429-11	CARBON 10K	5% 1/4W
EP302	1-537-771-21	TERMINAL BOARD, GROUND		R116	1-249-439-11	CARBON 68K	5% 1/4W
< FERRITE BEAD >				R117	1-249-439-11	CARBON 68K	5% 1/4W
FB4	1-410-396-41	INDUCTOR, FERRITE BEAD		R121	1-249-441-11	CARBON 100K	5% 1/4W
FB501	1-410-396-41	INDUCTOR, FERRITE BEAD		R123	1-249-429-11	CARBON 10K	5% 1/4W
FB502	1-410-396-41	INDUCTOR, FERRITE BEAD		R124	1-249-429-11	CARBON 10K	5% 1/4W
FB503	1-410-396-41	INDUCTOR, FERRITE BEAD		R125	1-249-433-11	CARBON 22K	5% 1/4W
FB504	1-410-396-41	INDUCTOR, FERRITE BEAD		R126	1-249-438-11	CARBON 56K	5% 1/4W
FB507	1-410-396-41	INDUCTOR, FERRITE BEAD		R127	1-249-429-11	CARBON 10K	5% 1/4W
< IC >				R128	1-249-429-11	CARBON 10K	5% 1/4W
IC101	8-759-434-43	IC CXA8065S		R129	1-249-438-11	CARBON 56K	5% 1/4W
IC201	8-759-426-99	IC CXD8607N		R130	1-249-433-11	CARBON 22K	5% 1/4W
IC301	8-749-012-70	IC GP1F38R (MD DIGITAL OPTICAL DIGITAL IN CD PLAYER)		R131	1-249-429-11	CARBON 10K	5% 1/4W
IC302	8-749-012-70	IC GP1F38R (MD DIGITAL OPTICAL DIGITAL IN VIDEO 2)		R132	1-249-429-11	CARBON 10K	5% 1/4W
IC303	8-759-917-18	IC SN74HCU04AN		R134	1-249-441-11	CARBON 100K	5% 1/4W
IC304	8-759-916-12	IC SN74HC00AN		R141	1-249-433-11	CARBON 22K	5% 1/4W
IC311	8-759-822-09	IC LB1641		R142	1-249-433-11	CARBON 22K	5% 1/4W
IC401	8-759-456-21	IC RU8X12MF-0010		R143	1-249-435-11	CARBON 33K	5% 1/4W
IC501	8-759-426-96	IC LA5620		R144	1-249-435-11	CARBON 33K	5% 1/4W
IC541	8-759-708-06	IC NJM78L06A		R145	1-249-433-11	CARBON 22K	5% 1/4W
IC551	8-759-700-69	IC NJM79L12A		R146	1-249-433-11	CARBON 22K	5% 1/4W
< PIN JACK >				R147	1-249-435-11	CARBON 33K	5% 1/4W
J101	1-770-720-11	JACK, PIN 4P (MD ANALOG IN/OUT)		R148	1-249-435-11	CARBON 33K	5% 1/4W
< COIL >				R150	1-249-429-11	CARBON 10K	5% 1/4W
L1	1-414-142-11	INDUCTOR 1uH		R151	1-249-437-11	CARBON 47K	5% 1/4W
L2	1-414-142-11	INDUCTOR 1uH		R152	1-249-413-11	CARBON 470	5% 1/4W
L3	1-410-509-11	INDUCTOR 10uH		R153	1-249-441-11	CARBON 100K	5% 1/4W
L5	1-410-324-11	INDUCTOR 4.7uH		R160	1-249-429-11	CARBON 10K	5% 1/4W
L391	1-408-117-00	INDUCTOR 10uH		R161	1-249-437-11	CARBON 47K	5% 1/4W
L392	1-408-117-00	INDUCTOR 10uH		R162	1-249-413-11	CARBON 470	5% 1/4W
< TRANSISTOR >				R163	1-249-441-11	CARBON 100K	5% 1/4W
Q311	8-729-119-76	TRANSISTOR 2SA1175-HFE		R201	1-249-401-11	CARBON 47	5% 1/4W
Q312	8-729-900-80	TRANSISTOR DTC114ES		R202	1-249-401-11	CARBON 47	5% 1/4W
Q351	8-729-620-05	TRANSISTOR 2SC2603-EF		R206	1-249-401-11	CARBON 47	5% 1/4W
Q454	8-729-422-57	TRANSISTOR UN4111		R215	1-249-401-11	CARBON 47	5% 1/4W
Q455	8-729-422-57	TRANSISTOR UN4111		R225	1-249-413-11	CARBON 470	5% 1/4W
				R235	1-249-411-11	CARBON 330	5% 1/4W
				R236	1-247-903-00	CARBON 1M	5% 1/4W
				R252	1-249-401-11	CARBON 47	5% 1/4W
				R253	1-249-401-11	CARBON 47	5% 1/4W
				R255	1-249-401-11	CARBON 47	5% 1/4W
				R256	1-249-401-11	CARBON 47	5% 1/4W
				R301	1-247-895-00	CARBON 470K	5% 1/4W

Ref. No.	Part No.	Description	Remark	Ref. No.	Part No.	Description	Remark	
R302	1-247-895-00	CARBON	470K 5% 1/4W	i R541	1-247-702-11	CARBON 150 5% 1/4W	F	
R303	1-249-437-11	CARBON	47K 5% 1/4W	i R542	1-247-702-11	CARBON 150 5% 1/4W	F	
R304	1-249-437-11	CARBON	47K 5% 1/4W	i R543	1-247-702-11	CARBON 150 5% 1/4W	F	
R311	1-249-429-11	CARBON	10K 5% 1/4W	i R544	1-247-702-11	CARBON 150 5% 1/4W	F	
R312	1-249-429-11	CARBON	10K 5% 1/4W	i R545	1-247-702-11	CARBON 150 5% 1/4W	F	
R313	1-249-429-11	CARBON	10K 5% 1/4W	i R546	1-247-702-11	CARBON 150 5% 1/4W	F	
R316	1-249-403-11	CARBON	68 5% 1/4W	i R547	1-247-702-11	CARBON 150 5% 1/4W	F	
R318	1-249-429-11	CARBON	10K 5% 1/4W	i R548	1-247-702-11	CARBON 150 5% 1/4W	F	
R347	1-249-441-11	CARBON	100K 5% 1/4W	i R549	1-247-702-11	CARBON 150 5% 1/4W	F	
R351	1-249-429-11	CARBON	10K 5% 1/4W					
R352	1-249-425-11	CARBON	4.7K 5% 1/4W			< SWITCH >		
R353	1-249-429-11	CARBON	10K 5% 1/4W	S408	1-554-303-21	SWITCH, TACTILE (POWER)		
R354	1-249-393-11	CARBON	10 5% 1/4W			< VIBRATOR >		
R355	1-247-807-31	CARBON	100 5% 1/4W	X201	1-579-314-11	VIBRATOR, CRYSTAL (22MHz)		
R403	1-249-429-11	CARBON	10K 5% 1/4W	X401	1-567-098-61	VIBRATOR, CRYSTAL (32.768kHz)		
R404	1-249-429-11	CARBON	10K 5% 1/4W	X402	1-767-157-21	VIBRATOR, CERAMIC (12MHz)		
R405	1-249-429-11	CARBON	10K 5% 1/4W			*****		
R406	1-249-429-11	CARBON	10K 5% 1/4W	*	A-4699-657-A	PANEL BOARD, COMPLETE		
R407	1-249-429-11	CARBON	10K 5% 1/4W			*****		
R408	1-249-429-11	CARBON	10K 5% 1/4W					
R409	1-249-429-11	CARBON	10K 5% 1/4W					
R427	1-247-903-00	CARBON	1M 5% 1/4W		1-690-880-51	LEAD (WITH CONNECTOR)		
R435	1-249-441-11	CARBON	100K 5% 1/4W		2-389-320-01	CUSHION		
R436	1-249-429-11	CARBON	10K 5% 1/4W	*	4-956-134-01	HOLDER (FL TUBE)		
R437	1-249-441-11	CARBON	100K 5% 1/4W		7-685-872-09	SCREW +BVTT 3X8 (S)		
R438	1-249-441-11	CARBON	100K 5% 1/4W			< CAPACITOR >		
R441	1-249-441-11	CARBON	100K 5% 1/4W	C97	1-164-159-11	CERAMIC 0.1uF 50V		
R442	1-249-441-11	CARBON	100K 5% 1/4W	C701	1-164-159-11	CERAMIC 0.1uF 50V		
R450	1-249-429-11	CARBON	10K 5% 1/4W	C702	1-164-159-11	CERAMIC 0.1uF 50V		
R451	1-249-429-11	CARBON	10K 5% 1/4W	C703	1-126-791-11	ELECT 10uF 20% 35V		
R459	1-249-417-11	CARBON	1K 5% 1/4W	C705	1-162-282-31	CERAMIC 100PF 10% 50V		
R462	1-249-441-11	CARBON	100K 5% 1/4W	C706	1-162-282-31	CERAMIC 100PF 10% 50V		
R463	1-249-441-11	CARBON	100K 5% 1/4W					
R467	1-249-429-11	CARBON	10K 5% 1/4W	C707	1-162-282-31	CERAMIC 100PF 10% 50V		
R468	1-249-429-11	CARBON	10K 5% 1/4W	C708	1-162-282-31	CERAMIC 100PF 10% 50V		
R469	1-249-429-11	CARBON	10K 5% 1/4W	C709	1-162-282-31	CERAMIC 100PF 10% 50V		
R481	1-249-437-11	CARBON	47K 5% 1/4W	C710	1-162-282-31	CERAMIC 100PF 10% 50V		
R483	1-249-437-11	CARBON	47K 5% 1/4W	C711	1-162-282-31	CERAMIC 100PF 10% 50V		
R490	1-249-429-11	CARBON	10K 5% 1/4W					
R494	1-249-441-11	CARBON	100K 5% 1/4W	C712	1-162-282-31	CERAMIC 100PF 10% 50V		
R496	1-249-429-11	CARBON	10K 5% 1/4W	C713	1-162-282-31	CERAMIC 100PF 10% 50V		
R497	1-249-429-11	CARBON	10K 5% 1/4W	C714	1-162-282-31	CERAMIC 100PF 10% 50V		
R498	1-249-429-11	CARBON	10K 5% 1/4W	C715	1-162-282-31	CERAMIC 100PF 10% 50V		
R509	1-249-429-11	CARBON	10K 5% 1/4W	C716	1-162-282-31	CERAMIC 100PF 10% 50V		
R513	1-249-429-11	CARBON	10K 5% 1/4W					
R514	1-249-429-11	CARBON	10K 5% 1/4W	C717	1-162-282-31	CERAMIC 100PF 10% 50V		
R515	1-249-417-11	CARBON	1K 5% 1/4W	C718	1-162-282-31	CERAMIC 100PF 10% 50V		
R516	1-247-807-31	CARBON	100 5% 1/4W	C719	1-162-282-31	CERAMIC 100PF 10% 50V		
R521	1-249-393-11	CARBON	10 5% 1/4W	C720	1-162-282-31	CERAMIC 100PF 10% 50V		
R522	1-249-425-11	CARBON	4.7K 5% 1/4W	C721	1-162-282-31	CERAMIC 100PF 10% 50V		
R523	1-249-429-11	CARBON	10K 5% 1/4W					
R531	1-249-413-11	CARBON	470 5% 1/4W	C722	1-162-282-31	CERAMIC 100PF 10% 50V		
R532	1-249-413-11	CARBON	470 5% 1/4W	C723	1-162-282-31	CERAMIC 100PF 10% 50V		
R533	1-249-441-11	CARBON	100K 5% 1/4W	C724	1-162-282-31	CERAMIC 100PF 10% 50V		
i R540	1-247-702-11	CARBON	150 5% 1/4W	F	C725	1-162-282-31	CERAMIC 100PF 10% 50V	
					C726	1-162-282-31	CERAMIC 100PF 10% 50V	
					C741	1-162-282-31	CERAMIC 100PF 10% 50V	
					C742	1-162-282-31	CERAMIC 100PF 10% 50V	

The components identified by mark Δ or dotted line with mark Δ are critical for safety. Replace only with part number specified.

PANEL

REC VOL

SW

Ref. No.	Part No.	Description	Remark		
C756	1-164-159-11	CERAMIC	0.1uF		50V
C758	1-162-215-31	CERAMIC	47PF	5%	50V
C760	1-162-294-31	CERAMIC	0.001uF	10%	50V
C761	1-162-294-31	CERAMIC	0.001uF	10%	50V
C762	1-162-294-31	CERAMIC	0.001uF	10%	50V
< CONNECTOR >					
CN701	1-778-449-11	CONNECTOR, FFC/FPC 19P			
< LED >					
D731	8-719-057-09	LED LNJ801LPDJA (I◀◀ SELECTOR ▶▶I)			
D732	8-719-057-09	LED LNJ801LPDJA (ENTER/YES)			
D733	8-719-058-17	LED LNG401NPYJA (ANALOG IN)			
D734	8-719-058-17	LED LNG401NPYJA (32kHz)			
D735	8-719-058-17	LED LNG401NPYJA (44.1kHz)			
D736	8-719-058-17	LED LNG401NPYJA (48kHz)			
< FERRITE BEAD >					
FB1	1-410-396-41	INDUCTOR, FERRITE BEAD			
< FLUORESCENT INDICATOR TUBE >					
FL701	1-517-575-11	INDICATOR TUBE, FLUORESCENT			
< IC >					
IC701	8-759-426-98	IC MSM9202-02GS-K			
< TRANSISTOR >					
Q701	8-729-422-57	TRANSISTOR UN4111			
Q702	8-729-422-57	TRANSISTOR UN4111			
Q703	8-729-620-05	TRANSISTOR 2SC2603-EF			
< RESISTOR >					
R702	1-249-421-11	CARBON	2.2K	5%	1/4W
R703	1-247-843-11	CARBON	3.3K	5%	1/4W
R704	1-249-425-11	CARBON	4.7K	5%	1/4W
R705	1-249-429-11	CARBON	10K	5%	1/4W
R706	1-249-435-11	CARBON	33K	5%	1/4W
R712	1-249-421-11	CARBON	2.2K	5%	1/4W
R713	1-247-843-11	CARBON	3.3K	5%	1/4W
R714	1-249-431-11	CARBON	15K	5%	1/4W
R722	1-249-421-11	CARBON	2.2K	5%	1/4W
R723	1-247-843-11	CARBON	3.3K	5%	1/4W
R724	1-249-425-11	CARBON	4.7K	5%	1/4W
R725	1-249-429-11	CARBON	10K	5%	1/4W
R726	1-249-435-11	CARBON	33K	5%	1/4W
R731	1-249-397-11	CARBON	22	5%	1/4W
R732	1-249-397-11	CARBON	22	5%	1/4W
R733	1-249-401-11	CARBON	47	5%	1/4W
R735	1-249-401-11	CARBON	47	5%	1/4W
R758	1-247-842-11	CARBON	3K	5%	1/4W
R760	1-247-807-31	CARBON	100	5%	1/4W

Ref. No.	Part No.	Description	Remark		
R761	1-247-807-31	CARBON	100	5%	1/4W
R762	1-247-807-31	CARBON	100	5%	1/4W
R763	1-247-807-31	CARBON	100	5%	1/4W
< SWITCH >					
S701	1-554-303-21	SWITCH, TACTILE (▷◻◻)			
S702	1-554-303-21	SWITCH, TACTILE (▶▶)			
S703	1-554-303-21	SWITCH, TACTILE (◀◀)			
S704	1-554-303-21	SWITCH, TACTILE (■)			
S705	1-554-303-21	SWITCH, TACTILE (ENTER/YES)			
S706	1-554-303-21	SWITCH, TACTILE (EDIT/NO)			
S711	1-554-303-21	SWITCH, TACTILE (≡ EJECT)			
S712	1-554-303-21	SWITCH, TACTILE (PROGRAM)			
S713	1-554-303-21	SWITCH, TACTILE (SHUFFLE)			
S714	1-554-303-21	SWITCH, TACTILE (CONTINUE)			
S722	1-554-303-21	SWITCH, TACTILE (SCROLL)			
S723	1-554-303-21	SWITCH, TACTILE (DISPLAY/CHARACTER)			
S724	1-554-303-21	SWITCH, TACTILE (REPEAT)			
S725	1-554-303-21	SWITCH, TACTILE (CD SYNC)			
S726	1-554-303-21	SWITCH, TACTILE (● REC)			
S741	1-467-938-11	ENCODER, ROTARY (I◀◀ SELECTOR ▶▶I)			

*	1-663-192-11	REC VOL BOARD			

< CONNECTOR >					
* CN801	1-568-848-11	SOCKET, CONNECTOR 5P			
< VARIABLE RESISTOR >					
RV801	1-225-417-11	RES, VAR, CARBON 20k×2 (REC LEVEL)			

*	1-661-774-11	SW BOARD			

< CONNECTOR >					
CN601	1-770-698-11	CONNECTOR, FFC/FPC 15P			
CN602	1-778-638-21	PIN, CONNECTOR (PC BOARD) 2P			
CN603	1-778-638-21	PIN, CONNECTOR (PC BOARD) 2P			
< SWITCH >					
S681	1-572-467-61	SWITCH, PUSH (1 KEY) (LIMIT IN)			
S682	1-692-377-31	SWITCH, PUSH (1 KEY) (REFLECT)			
S683	1-692-847-21	SWITCH, PUSH (1 KEY) (PROTECT)			
S685	1-572-467-61	SWITCH, PUSH (1 KEY) (CHUCKING IN)			
S686	1-762-621-21	SWITCH, PUSH (1 KEY) (PACK OUT)			
S687	1-572-688-11	SWITCH, PUSH (1 KEY) (PB POSITION)			
S688	1-762-621-21	SWITCH, PUSH (1 KEY) (REC POSITION)			

MISCELLANEOUS					

10	1-777-654-11	WIRE (FLAT TYPE) (19 CORE)			

Ref. No.	Part No.	Description	Remark
11	1-777-558-11	WIRE (FLAT TYPE) (19 CORE)	
12	1-777-559-11	WIRE (FLAT TYPE) (29 CORE)	
20	1-777-473-11	WIRE (FLAT TYPE) (5 CORE)	
56	1-660-966-11	OP RELAY FLEXIBLE BOARD	
58	1-777-517-11	WIRE (FLAT TYPE) (15 CORE)	
i 117	8-583-028-02	OPTICAL PICK-UP KMS-260A/J1N	
HR901	1-500-396-11	HEAD, OVER WRITE	
M901	A-4672-135-A	MOTOR ASSY, SPINDLE	
M902	A-4672-133-A	MOTOR ASSY, SLED	
M903	A-4672-134-A	MOTOR ASSY, LOADING	

HARDWARE LIST

#1	7-685-647-79	SCREW +BVTP 3X10 TYPE2 N-S
#2	7-685-850-04	SCREW +BVTT 2X3 (S)
#3	7-627-553-17	PRECISION SCREW +P 2X2 TYPE 3
#4	7-627-552-27	SCREW, PRECISION +P 1.7X2
#5	7-685-851-04	SCREW +BVTT 2X4 (S)
#6	7-685-871-01	SCREW +BVTT 3X6 (S)
#7	7-627-852-28	+P 1.7X3

The components identified by mark Δ or dotted line with mark Δ are critical for safety. Replace only with part number specified.

