

DAEWOO

Service Manual

Microwave Oven

Model: KOC-972T0S
KOC-972T2S
KOC-982T1S
KOC-982T2S
KOC-983T1S
KOC-983T2S
KOC-984T1S
KOC-984T2S
KOC-985T1S
KOC-985T2S

✓ Caution

: In this Manual, some parts can be changed for improving, their performance without notice in the parts list. So, if you need the latest parts information, please refer to PPL(Parts Price List) in Service Information Center (<http://svc.dwe.co.kr>).



PRECAUTIONS TO BE OBSERVED BEFORE AND DURING SERVICING TO AVOID POSSIBLE EXPOSURE TO EXCESSIVE MICROWAVE ENERGY

- (a) Do not operate or allow the oven to be operated with the door open.
- (b) Make the following safety checks on all ovens to be serviced before activating the magnetron or other microwave source, and make repairs as necessary: (1) Interlock operation, (2) Proper door closing, (3) Seal and sealing surfaces (arcing, wear, and other damage), (4) Damage to or loosening of hinges and latches, (5) Evidence of dropping or abuse.
- (c) Before turning on power to the microwave oven for any service test or inspection within the microwave generating compartments, check the magnetron, wave guide or transmission line, and cavity for proper alignment, integrity, and connections.
- (d) Any defective or misadjusted components in the interlock, monitor, door seal, and microwave generation and transmission systems shall be repaired, replaced, or adjusted by procedures described in this manual before the oven is released to the owner.
- (e) A microwave leakage check to verify compliance with the Federal performance standard should be performed on each oven prior to release to the owner.

TABLE OF CONTENTS

SAFETY AND PRECAUTIONS	2
SPECIFICATIONS	3
EXTERNAL VIEW	4
1. OUTER DIMENSION.....	4
2. FEATURE DIAGRAM	5
INSTALLATION	7
EARTHING INSTRUCTIONS.....	7
CONTROL PANEL	8
DISASSEMBLY AND ASSEMBLY.....	9
INTERLOCK MECHANISM AND ADJUSTMENT	23
TROUBLE SHOOTING GUIDE	24
MEASUREMENT AND TEST	30
1. MEASUREMENT OF THE MICROWAVE POWER OUTPUT	30
2. ELECTRICAL CONTINUITY CHECK OF INTERLOCK SWITCH.....	31
3. MICROWAVE RADIATION TEST	32
4. COMPONENT TEST PROCEDURE	33
WIRING DIAGRAM.....	34
SCHEMATIC DIAGRAM.....	35
EXPLODED VIEWS AND PARTS LIST	38
PRINTED WIRING BOARD	44
P.C.B. CIRCUIT DIAGRAM.....	49

SAFETY AND PRECAUTIONS

1. FOR SAFE OPERATION

Damage that allows the microwave energy (that cooks or heats the food) to escape will result in poor cooking and may cause serious bodily injury to the operator.

IF ANY OF THE FOLLOWING CONDITIONS EXIST, OPERATOR MUST NOT USE THE APPLIANCE.

(Only a trained service personnel should make repairs.)

- (1) A broken door hinge.
- (2) A broken door viewing screen.
- (3) A broken front panel, oven cavity.
- (4) A loosened door lock.
- (5) A broken door lock.

The door gasket plate and oven cavity surface should be kept clean.

No grease, soil or spatter should be allowed to build up on these surfaces or inside the oven.

DO NOT ATTEMPT TO OPERATE THIS APPLIANCE WITH THE DOOR OPEN.

The microwave oven has concealed switches to make sure the power is turned off when the door is opened.

Do not attempt to defeat them.

DO NOT ATTEMPT TO SERVICE THIS APPLIANCE UNTIL YOU HAVE READ THIS SERVICE MANUAL.

2. FOR SAFE SERVICE PROCEDURES

1. If the oven is operative prior to servicing, a microwave emission check should be performed prior to servicing the oven.
2. If any certified oven unit is found to servicing, a microwave emission check should be performed prior to servicing the oven.
 - (1) inform the manufacturer, importer or assembler,
 - (2) repair the unit at no cost to the owner,
 - (3) attempt to ascertain the cause of the excessive leakage,
 - (4) tell the owner of the unit not to use the unit until the oven has been brought into compliance.
3. If the oven operates with the door open, the service person should tell the user not to operate the oven and contact the manufacturer immediately.

IMPORTANT

The wire in this mains lead coloured in accordance with the following code.

Green-and-yellow	: Earth
Blue	: Neutral
Brown	: Live

As the colours of the wires in the mains lead of this appliance may not correspond with the coloured markings identifying the terminals in your plug, proceed as follows.

The wire which is coloured green-and-yellow must be connected to the terminal in the plug which is marked with the letter 'E', earth symbol or coloured green-and-yellow.

The wire which is coloured blue must be connected to the terminal which is marked with the letter 'N' or coloured black.

The wire which is coloured brown must be connected to the terminal which is marked with the letter 'L' or coloured red.

NOTE

This oven is designed for counter-top use only.

SPECIFICATIONS

MODEL	KOC-972T0S	KOC-972T2S	
POWER SUPPLY	230V~50Hz	230V~50Hz	
POWER CONSUMPTION	MICROWAVE	1450W	1450W
	GRILL	1200W	1200W
	CONVECTION	1550W	1550W
	PROGRAM COOK	1850W	1850W
	COMBINATION	2600W (Simultaneous)	1550W (Sequential)
MICROWAVE ENERGY OUTPUT	950W(IEC705)	950W(IEC705)	
MICROWAVE FREQUENCY	2450MHz	2450MHz	
OUTSIDE DIMENSIONS (W X H X D)	526 x 345 x 413 mm (20.7 x 13.6 x 16.1 in.)		
CAVITY DIMENSIONS (W X H X D)	335 x 255 x 339 mm (13.2 x 10.0 x 13.3 in.)		
NET WEIGHT	APPROX. 20 Kg (44.2 lbs.)		
TIMER	60 minutes		
FUNCTION SELECTIONS	MICROWAVE/GRILL/CONVECTION/COMBI		
POWER SELECTIONS	10 LEVELS		
CAVITY VOLUME	1.0 Cu.Ft.		

MODEL	KOC-982T/983T/984T/985T1S	KOC-982T/983T/984T/985T2S	
POWER SUPPLY	230V~50Hz	230V~50Hz	
POWER CONSUMPTION	MICROWAVE	1450W	1450W
	GRILL	1200W	1200W
	CONVECTION	1550W	1550W
	PROGRAM COOK	1850W	1850W
	COMBINATION	2600W (Simultaneous)	1550W (Sequential)
MICROWAVE ENERGY OUTPUT	1000W(IEC705)	1000W(IEC705)	
MICROWAVE FREQUENCY	2450MHz	2450MHz	
OUTSIDE DIMENSIONS (W X H X D)	526 x 345 x 496 mm (20.7 x 13.6 x 19.5 in.)		
CAVITY DIMENSIONS (W X H X D)	335 x 250 x 339 mm (13.2 x 9.8 x 13.3 in.)		
NET WEIGHT	APPROX. 21 Kg (46.3 lbs.)		
TIMER	60 minutes		
FUNCTION SELECTIONS	MICROWAVE/GRILL/CONVECTION/COMBI		
POWER SELECTIONS	10 LEVELS		
CAVITY VOLUME	1.0 Cu.Ft.		

SPECIFICATIONS ARE SUBJECT TO CHANGE WITHOUT NOTICE.

EXTERNAL VIEW

1. OUTER DIMENSION

KOC-972T

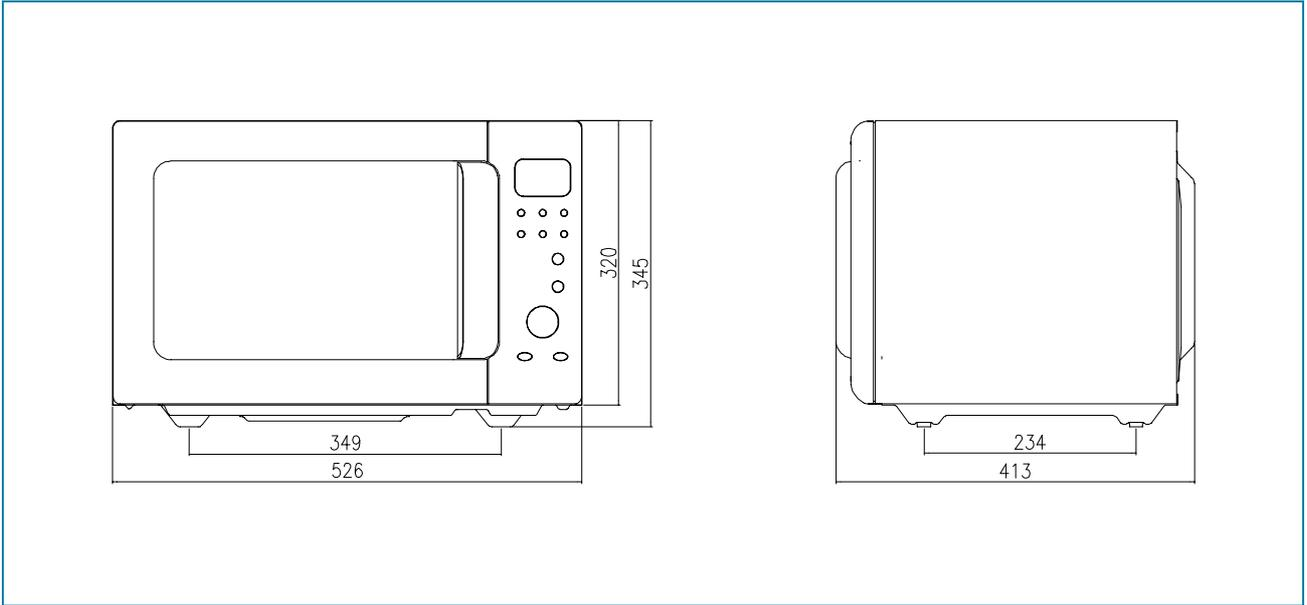

KOC-982T/983T/984T/985T

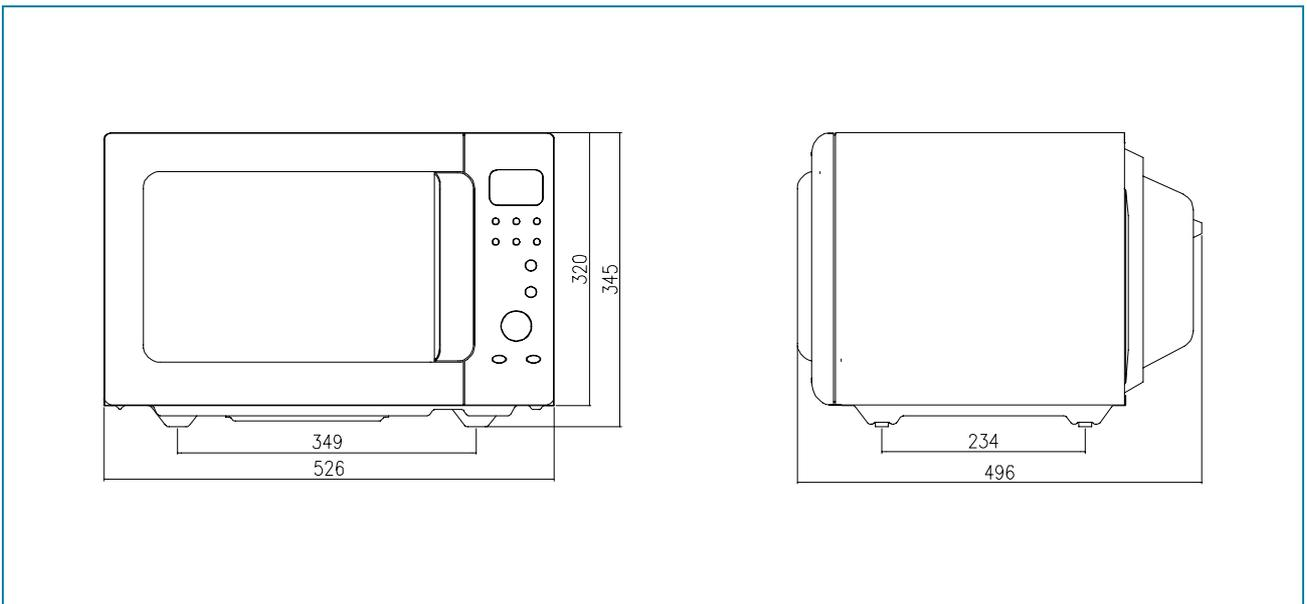

2. FEATURE DIAGRAM

KOC-972T

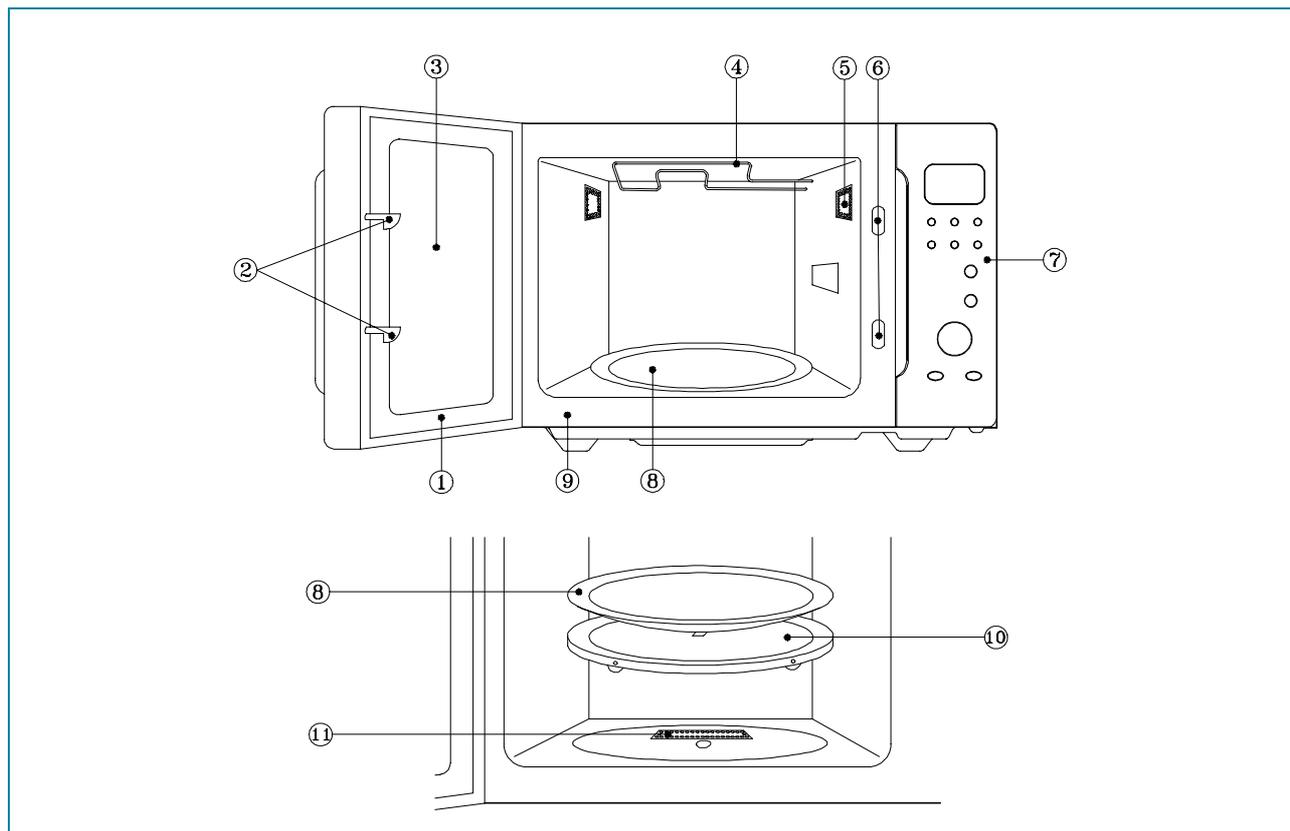

1. **Door seal** - Door seal maintains the microwave energy within the oven cavity and prevents microwave leakage.
2. **Door hook** - When the door is closed, it will automatically shut. If the door is opened while the oven is operating, the magnetron will immediately stop operating.
3. **Door viewing screen** - Allows viewing of food. The screen is designed so that light can pass through, but not the microwave.
4. **Top heater** - Turns on when convection, grill and combi cooking is selected.
5. **Oven lamp** - Automatically turns on during oven operating.
6. **Safety interlock system**
7. **Control panel**
8. **Turntable tray** - Rotates during cooking and ensure even distribution of Microwaves.
It can also be used as a cooking utensil.
9. **Oven front plate**
10. **Rotating base** - This fits over the shaft in the center of the ovens cavity floor.
This is to remain in the oven for all cooking. It should only be removed for cleaning.
11. **Under heater**

KOC-982T/983T/984T/985T

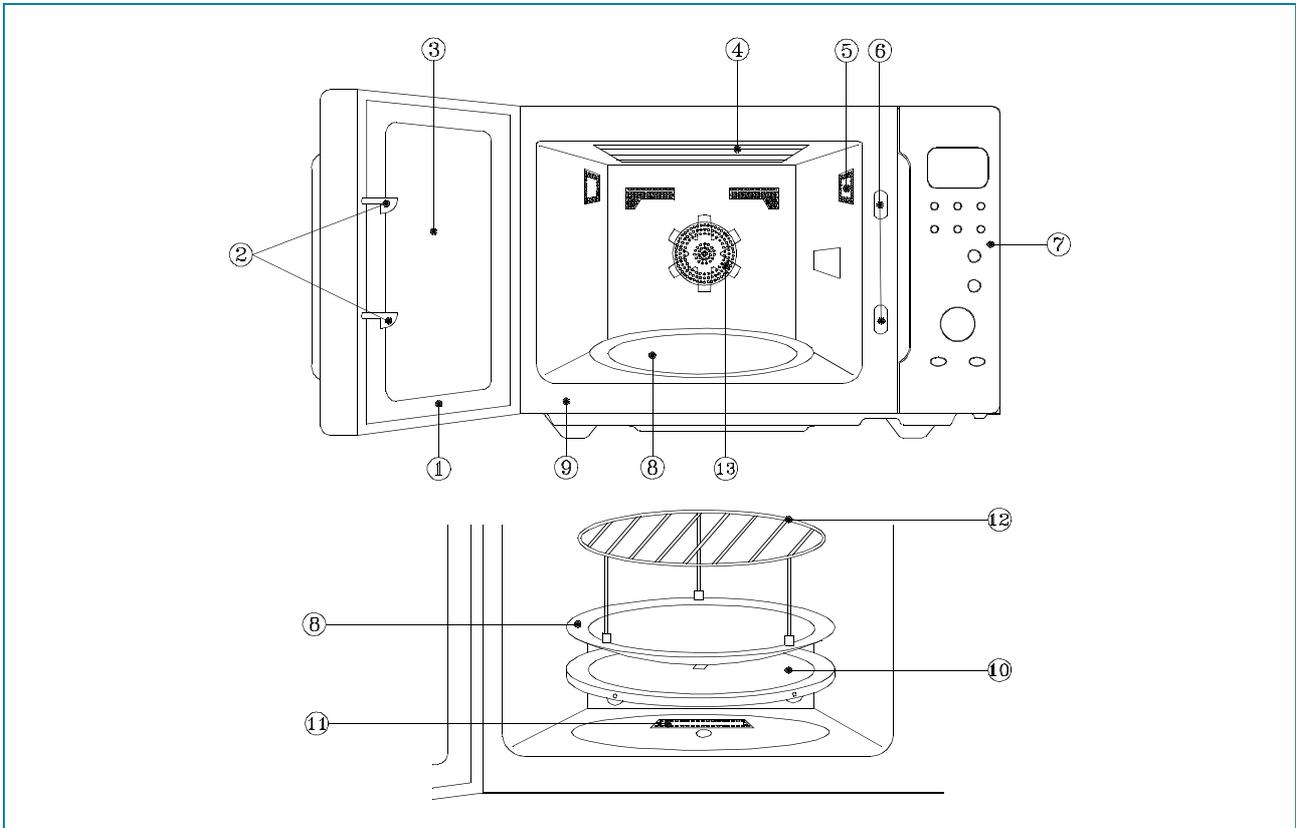

1. **Door seal** - Door seal maintains the microwave energy within the oven cavity and prevents microwave leakage.
2. **Door hook** - When the door is closed, it will automatically shut. If the door is opened while the oven is operating, the magnetron will immediately stop operating.
3. **Door viewing screen** - Allows viewing of food. The screen is designed so that light can pass through, but not the microwave.
4. **Top heater** - Turns on when convection, grill and combi cooking is selected.
5. **Oven lamp** - Automatically turns on during oven operating.
6. **Safety interlock system**
7. **Control panel**
8. **Turntable tray** - Rotates during cooking and ensure even distribution of Microwaves.
It can also be used as a cooking utensil.
9. **Oven front plate**
10. **Rotating base** - This fits over the shaft in the center of the ovens cavity floor.
This is to remain in the oven for all cooking. It should only be removed for cleaning.
11. **Under heater**
12. **Metal rack**
13. **Convection outlet & Fan**

INSTALLATION

1. Steady, flat location

This microwave oven should be set on a steady, flat surface.

This microwave oven is designed for counter top use only.

2. Leave space behind and side

All air vents should be kept a clearance. If all vents are covered during operation, the oven may overheat and, eventually, cause failure.

3. Away from radio and TV sets

Poor television reception and radio interference may result if the oven is located close to a TV, radio, antenna or feeder and so on. Position the oven as far from them as possible.

4. Away from heating appliances and water taps

Keep the oven away from hot air, steam or splash when choosing a place to position it, or the insulation might be adversely affected and breakdowns occur.

5. Power supply

Check your local power source. This microwave oven requires a current of approximately 13amperes, 230 Volts, 50 Hz. Power supply cord is about 1.2 meters long.

The voltage used must be the same as specified on this oven. Using a higher voltage may result in a fire or other accident causing oven damage. Using low voltage will cause slow cooking. We are not responsible for damage resulting from use of this oven with a voltage of ampere fuse other than those specified.

This appliance is supplied with cable of special type, which, if damaged, must be repaired with cable of same type.

Such a cable can be purchased from DAEWOO and must be installed by a Qualified Person.

6. Examine the oven after unpacking for any damage such as:

A misaligned door, broken door or a dent in cavity.

If any of the above are visible, DO NOT INSTALL, and notify dealer immediately.

7. Do not operate the oven if it is colder than room temperature.

(This may occur during delivery in cold weather.) Allow the oven to become room temperature before operating.

EARTHING INSTRUCTIONS

This appliance must be earthed. In the event of an electrical short circuit, earthing reduces the risk of the electric shock by providing an escape wire for the electric current. This appliance is equipped with a cord having a earthing wire with a earthing plug. The plug must be plugged into an outlet that is properly installed and earthed.

WARNING

Improper use of the earthing plug can result in a risk of electric shock.

Consult a qualified electrician or serviceman if the earthing instructions are not completely understood, or if doubt exists as to whether the appliance is properly earthed, and either:

If it is necessary to use an extension cord, use only a 3-wire extension cord that has a 3-blade earthing plug, and a 3-slot receptacle that will accept the plug on the appliance.

The marked rating of the extension cord should be equal to or greater than the electrical rating of the appliance, or Do not use an extension cord.

CONTROL PANEL

When blinking, the oven is operating in "COMBI" cooking mode.

When blinking, the oven is operating in "GRILL" cooking mode.

When blinking, the oven is operating in "MICROWAVE" cooking mode.

When blinking, the oven is operating in "PROGRAM COOK" cooking mode.

When blinking, the oven is operating in "PIE" cooking mode.

When blinking, the oven is operating in "CONVECTION" cooking mode.

Microwave Power Level-
Used to select the variable microwave power level. If this button(pad) is pressed for more than 1.3 sec, number is scrolled up automatically.

Dial Knob-
Used to input the cooking time and weight.

Stop/Clear Button-
Used to pause and clear all information manually put into the oven.

When blinking, the oven is operating in "WEIGHT DEFROST" cooking mode.

When blinking, the oven is operating in "TIME DEFROST" cooking mode.

When blinking, the oven is operating in weight input mode.

Temperature Button(pad)-
Used to set desired temperature. If this button is pressed for more than 1.3 sec, number is scrolled up automatically.

Function Buttons(pads)-
Used to select desired cooking function.
 • MW : MICROWAVE
 • GRILL
 • DEFROST : TIME or WEIGHT DEFROST
 • TEMP : CONVECTION
 • COMBI : COMBINATION
 • PIE
 • PROGRAM COOK

Speedy Cook Button(pad)-
Used to program quickly cooking time in 30 sec increments.

Start Button-
Used to start the selected cooking cycle.
(KOC-972T)

Start/Clock Button-
Used to start the selected cooking cycle and to set time.

(KOC-982T/983T/984T/985T)

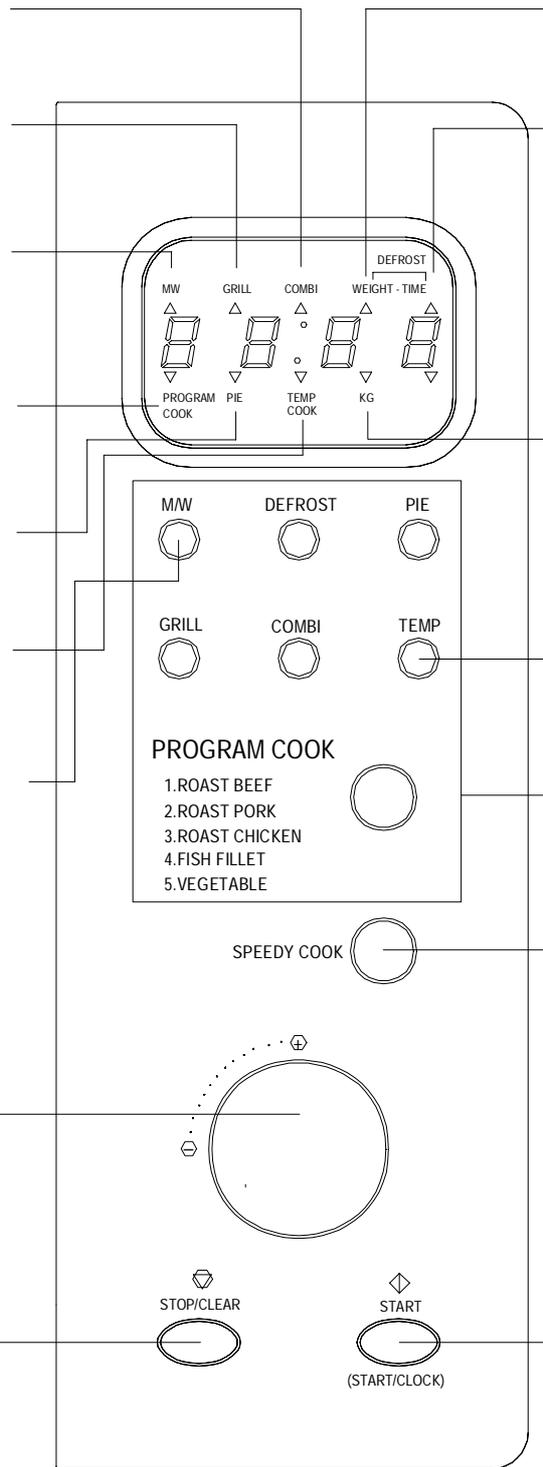

DISASSEMBLY AND ASSEMBLY

Cautions to be observed when trouble shooting.

Unlike many other appliances, the microwave oven is high-voltage, high-current equipment.

It is completely safety during normal operation.

However, carelessness in servicing the oven can result in an electric shock or possible danger from a short circuit.

You are asked to observe the following precautions carefully.

1. Always remove the power plug from the outlet before servicing.
2. Use an insulated screwdriver and wear rubber gloves when servicing the high voltage side.
3. Discharge the high voltage capacitor before touching any oven components or wiring.

(1) Check the earthed.

Do not operate on a two-wire extension cord.

The microwave oven is designed to be used with earthed.

It is imperative, therefore, to make sure it is earthed properly before beginning repair work.

(2) Warning about the electric charge in the high voltage capacitor.

For about 30 seconds after the operation stopped and electric charge remains in the high voltage capacitor.

When replacing or checking parts, short between oven chassis and the negative high terminal of the high voltage capacitor, by using a properly insulated screwdriver to discharge.

4. When the 15A fuse is blown out due to the operation of the monitor switch; replace primary interlock switch, secondary interlock switch and interlock monitor switch.
5. After repair or replacement of parts, make sure that the screws are properly tightened, and all electrical connections are tightened.
6. Do not operate without cabinet.

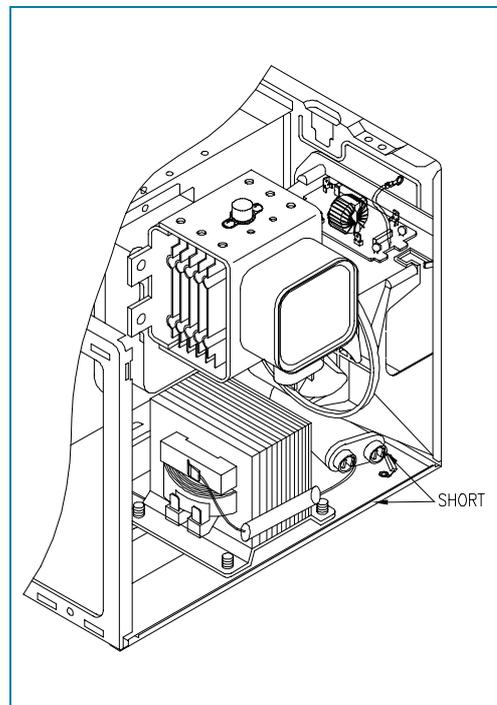

CAUTION

Service personnel should remove their watches whenever working close to or replacing the magnetron.

WARNING

When servicing the appliance, need a care of touching or replacing high potential parts because of electrical shock or exposing microwave. These parts are as follows - HV Transformer, Magnetron, HV Capacitor, HV Diode.

1. To remove cabinet

- (1) Remove four screws on cabinet back.
- (2) Push the cabinet backward.

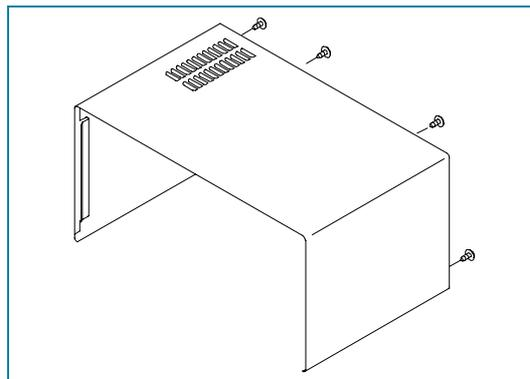

2. To remove guide wind assembly

- (1) Remove two screws for earthing and for fixing to rear-plate.
- (2) Remove the noise filter from the guide wind.
- (3) Pull the fan from the motor shaft.
- (4) Remove two screws which secure the motor shaded pole.
- (5) Remove the motor shaded pole.
- (6) Reverse the above steps for reassembly.

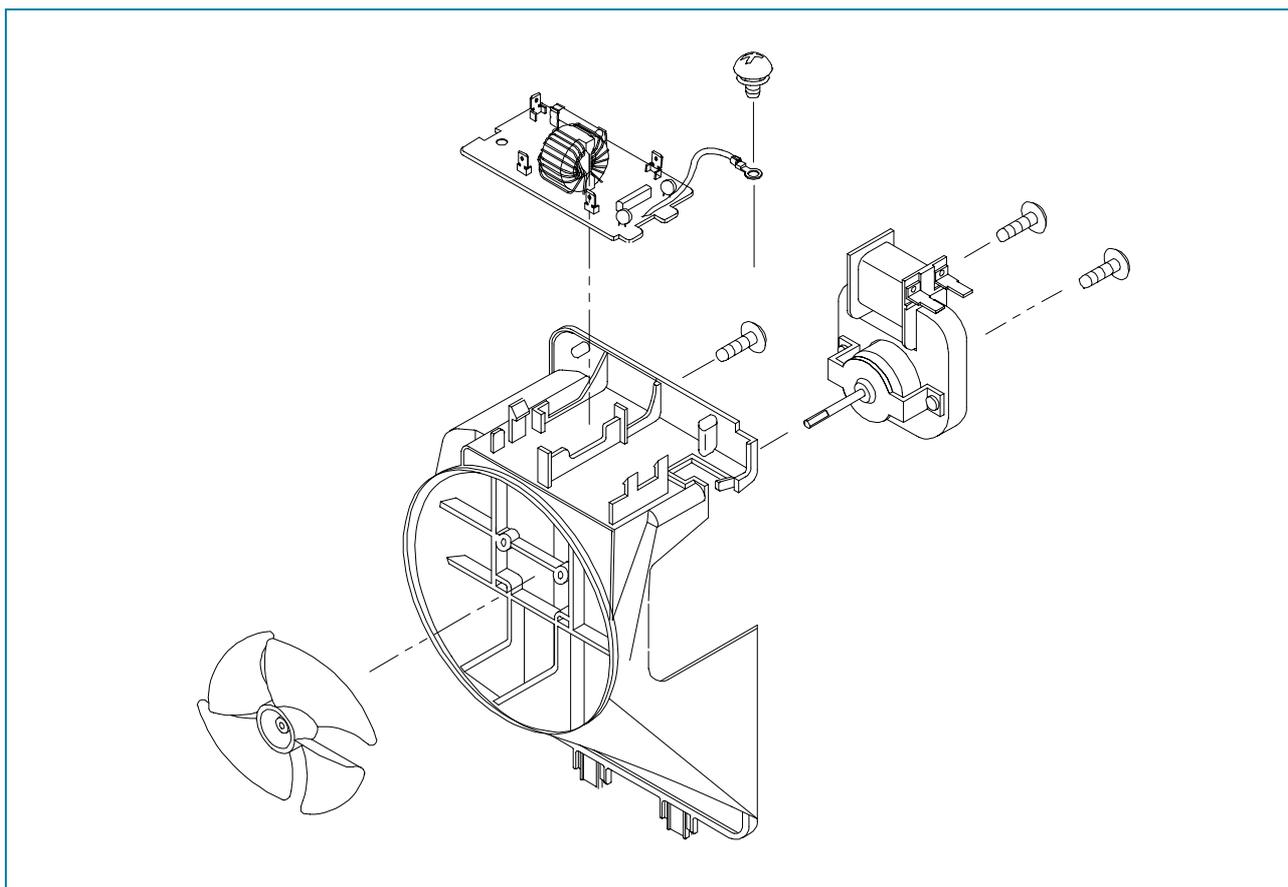

3. To remove H.V.transformer

- (1) Remove four screws which secure the H.V.transformer to the base plate.
- (2) Remove the H.V.transformer.
- (3) Reverse the above steps for reassembly.

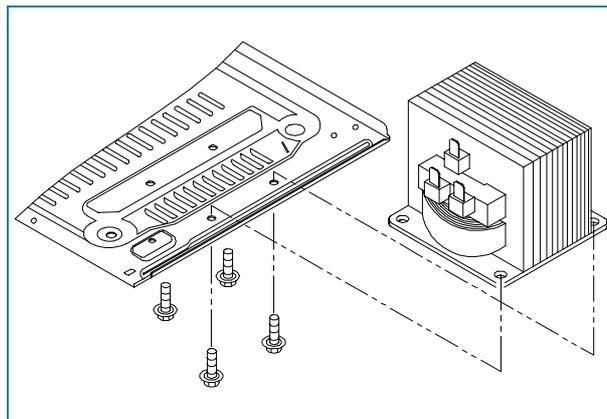

4. To remove high voltage capacitor

- (1) Remove a screw which secures the grounding ring terminal of the H.V. diode and the capacitor holder.
- (2) Remove the H.V. diode from the capacitor holder.
- (3) Reverse the above steps for reassembly.

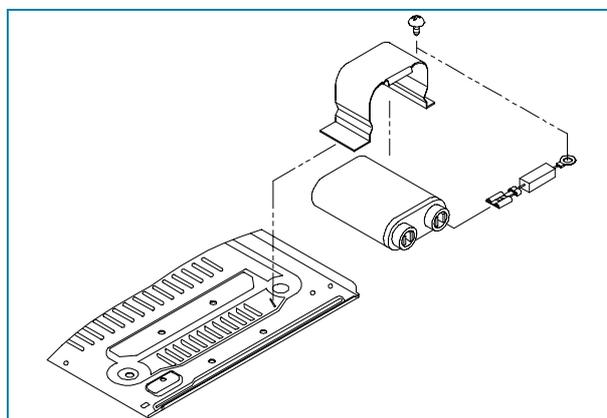

High voltage circuit wiring

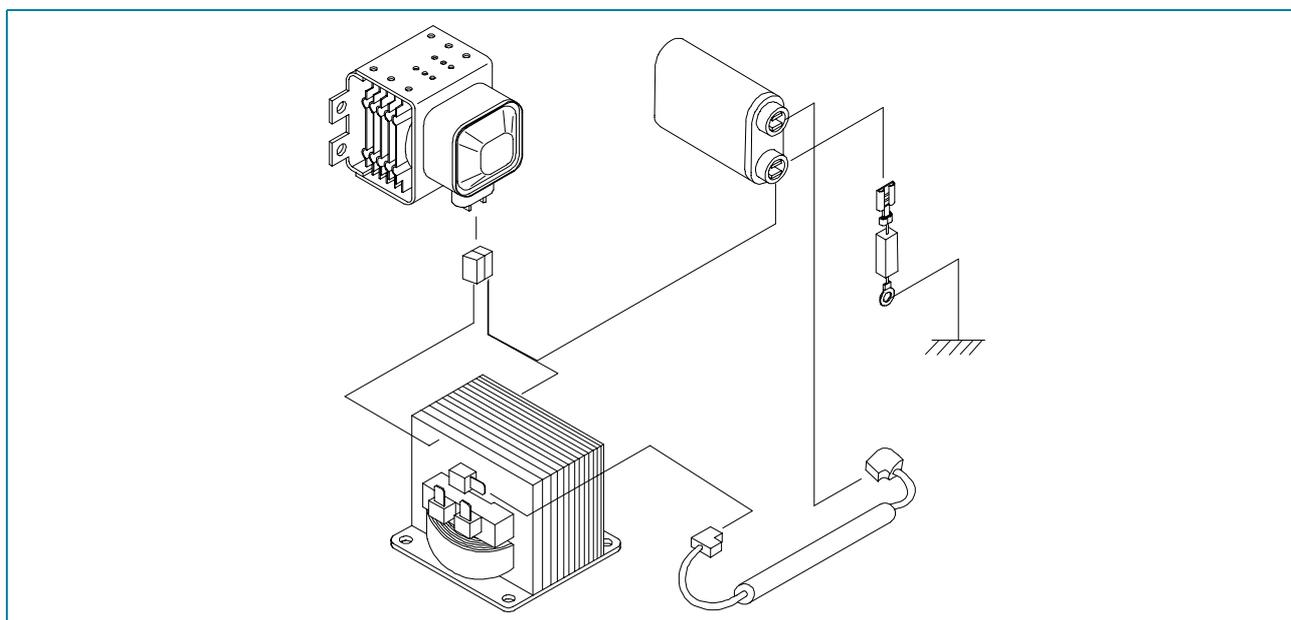

5. To remove magnetron

- (1) Remove three screws which secure the magnetron.
- (2) Remove the magnetron.
- (3) Reverse the above steps for reassembly.

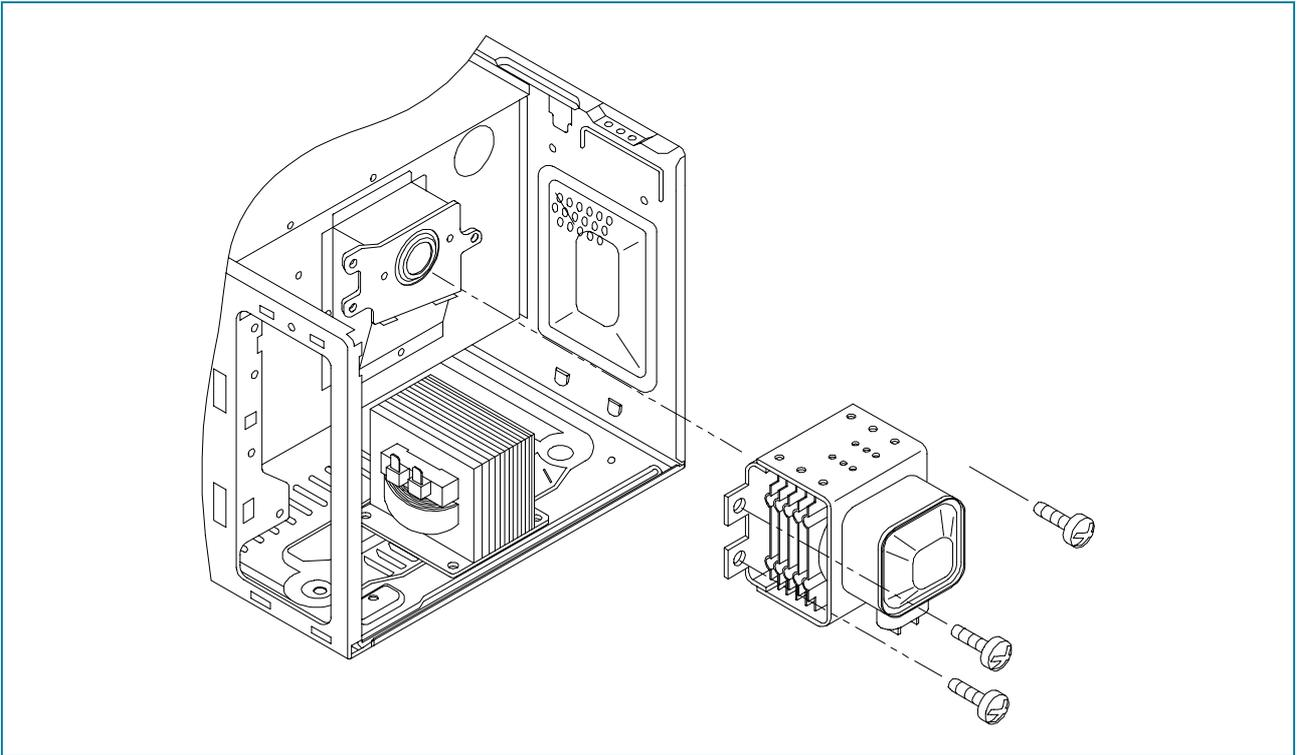

CAUTION

Never install the magnetron without the metallic gasket plate which is packed with each magnetron to prevent microwave leakage. Whenever repair work is carried out on magnetron, check the microwave leakage. It shall not exceed $4\text{mW}/\text{cm}^2$ for a fully assembled oven with door normally closed.

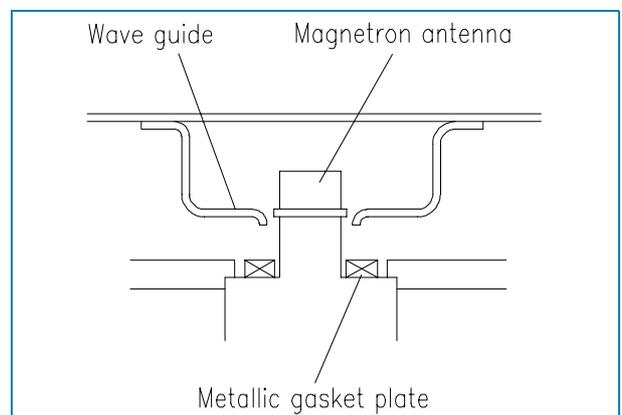
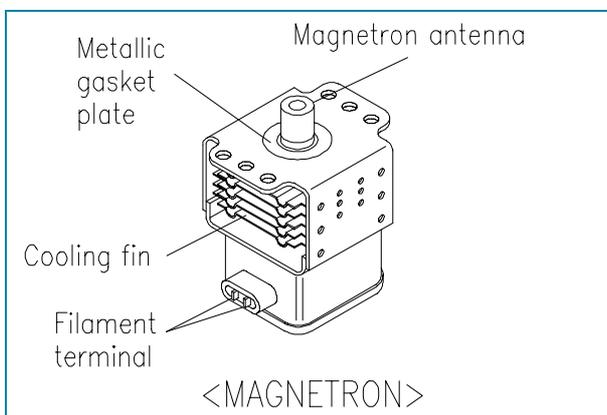

✓ **Caution:** In this Service Manual, some parts can be changed for improving, their performance without notice in the parts list. So, if you need the latest parts information, please refer to PPL(Parts Price List) in Service information Center(<http://svc.dwe.co.kr>)

6. To remove control panel assembly

KOC-972T, KOC-982T

- (1) Remove a screw which secure the control panel assembly to the oven front plate.
At the same time, draw forward the control panel assembly from the oven front plate.
- (2) Remove nine screws which secure the main and sub PCB assembly to control panel.
- (3) Remove buttons and dial knob.

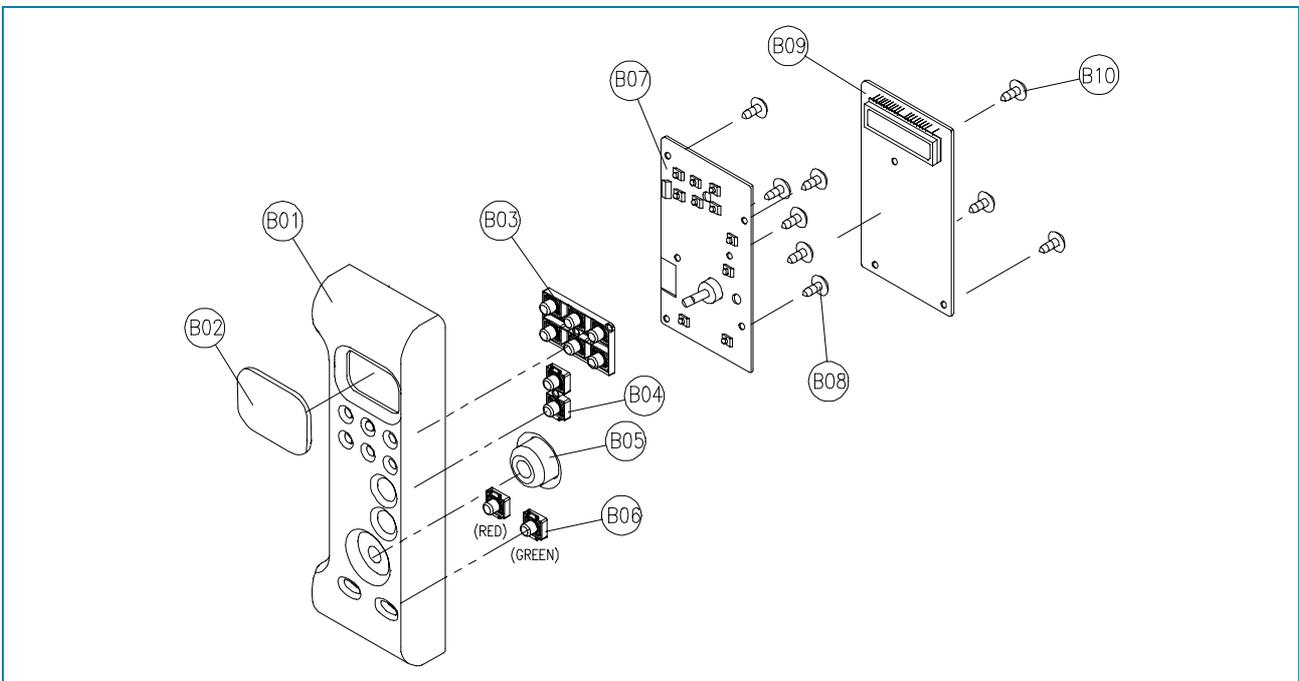
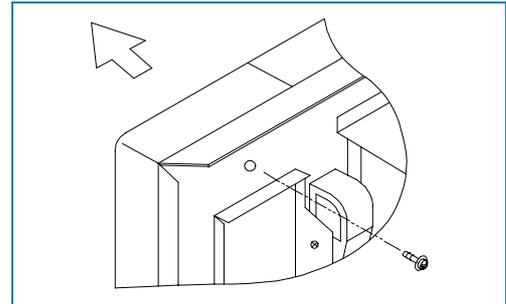

REF NO.	PART CODE	PART NAME	DESCRIPTION	QTY	REMARK
B01	3516715120	CONTROL-PANEL	ABS XR-401	1	
B02	3515501210	WINDOW DISPLAY	PMMA IF-850	1	
B03	3516905100	BUTTON FUNCTION-A	ABS XR-401	1	
B04	3516906200	BUTTON FUNCTION-B	ABS XR-401	1	
B05	3513404600	KNOB VOLUME	ABS XR-401	1	
B06	3516906300	BUTTON FUNCTION-C	ABS XR-401	2	
B07	PKBPMSQ500	PCB SUB AS	KOC-972T, KOC-982T	1	
B09	PKMPMSQ300	PCB MAIN AS	KOC-972T0S	1	
	PKMPMSQ300	PCB MAIN AS	KOC-972T2S	1	
	PKMPMSQ350	PCB MAIN AS	KOC-982T1S	1	
	PKMPMSQ350	PCB MAIN AS	KOC-982T2S	1	
B10	7621301011	SCREW TAPPING	T2S PAN 3x10 PW MFZN	3	

✓ **Caution:** In this Service Manual, some parts can be changed for improving, their performance without notice in the parts list. So, if you need the latest parts information, please refer to PPL(Parts Price List) in Service information Center(<http://svc.dwe.co.kr>)

DISASSEMBLY AND ASSEMBLY

KOC-983T

- (1) Remove a screw which secure the control panel assembly to the oven front plate.
At the same time, draw forward the control panel assembly from the oven front plate.
- (2) Remove ten screws which secure the main and sub PCB assembly to control panel.
- (3) Remove buttons.
- (4) Remove the knob volume.

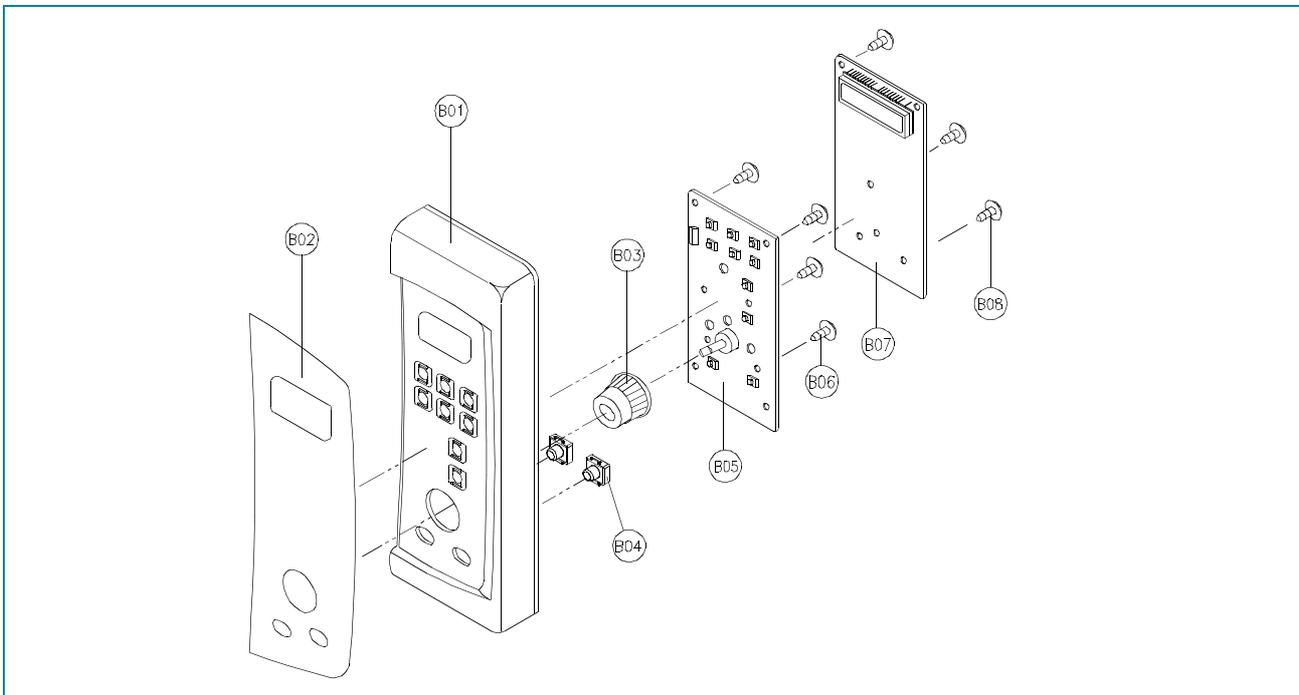
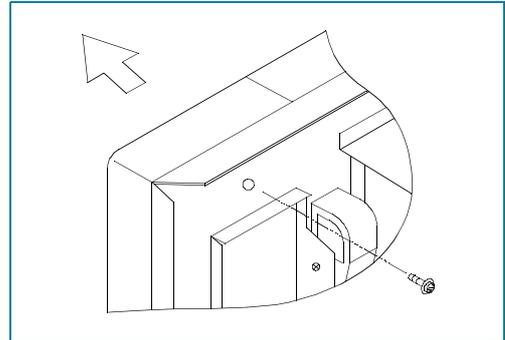

REF NO.	PART CODE	PART NAME	DESCRIPTION	QTY	REMARK
B01	3516719220	CONTROL-PANEL	ABS XR-401	1	
B02	3511603120	DECORATOR C-PANEL	PET T0.2	1	
B03	3513405200	KNOB VOLUME	ABS XR-401	1	
B04	3516906300	BUTTON FUNCTION	ABS XR-401	1	
B05	PKBPMSYB00	PCB SUB AS	KOC-984T	1	
B06	7621301011	SCREW TAPPING	T2S PAN 3X10 PW MFZN	6	
B07	PKMPMSYB00	PCB MAIN AS	KOC-983T1S KOC-983T2S	1	
B08	7122401211	SCREW TAPPING	T2S TRS 4X12 MFZN	4	

✓ **Caution:** In this Service Manual, some parts can be changed for improving, their performance without notice in the parts list. So, if you need the latest parts information, please refer to PPL(Parts Price List) in Service information Center(<http://svc.dwe.co.kr>)

DISASSEMBLY AND ASSEMBLY

KOC-984T

- (1) Remove a screw which secure the control panel assembly to the oven front plate.
At the same time, draw forward the control panel assembly from the oven front plate.
- (2) Remove the dial knob.
- (3) Remove ten screws which secure the main and sub PCB assembly to control panel.
- (4) Remove buttons.
- (5) Remove the decorator panel.

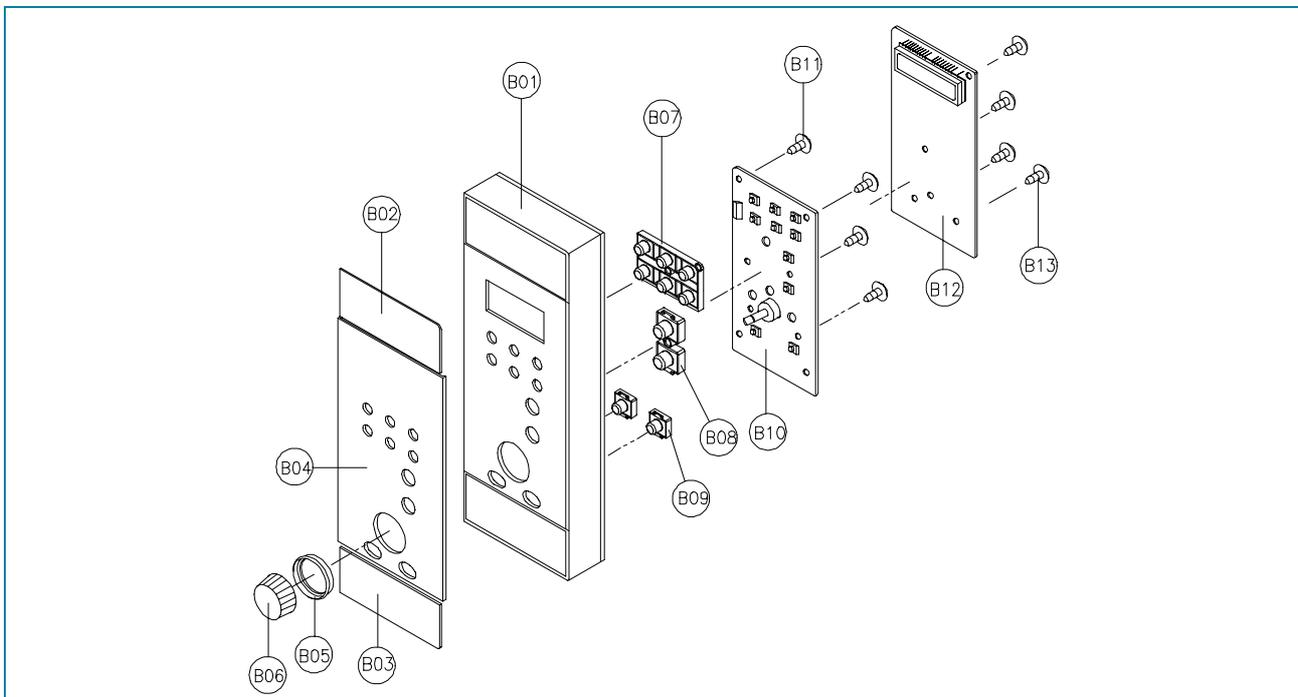
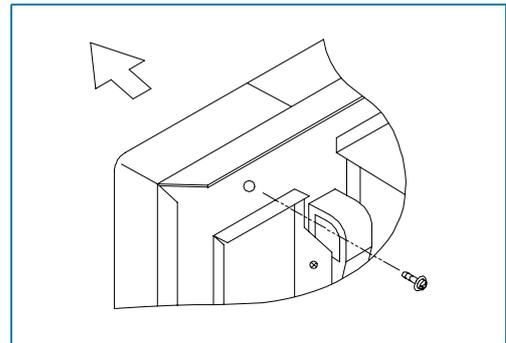

REF NO.	PART CODE	PART NAME	DESCRIPTION	QTY	REMARK
B01	3516719200	CONTROL-PANEL	ABS XR-401	1	
B02	3511602900	DECORATOR C/P *T	STS304 T0.6 H/L	1	
B03	3511603000	DECORATOR C/P *U	STS304 T0.6 H/L	1	
B04	3511603110	DECORATOR C-PANEL	PMMA IF-850	1	SMOG
B05	3511602800	DECORATOR RING	ABS XR-401	1	COATING
B06	3513404620	KNOB VOLUME	ABS XR-401	1	COATING
B07	3516905120	BUTTON FUNCTION	ABS XR-401	1	COATING
B08	3516907200	BUTTON FUNCTION	ABS XR-401	1	COATING
B09	3516906320	BUTTON FUNCTION	ABS XR-401	2	COATING
B10	PKBPM5YB00	PCB SUB AS	KOC-984T	1	
B12	PKMP5YB00	PCB MAIN AS	KOC-984T1S	1	
			KOC-984T2S		
B13	7122401211	SCREW TAPPING	T2S TRS 4x12 MFZN	4	

✓ **Caution:** In this Service Manual, some parts can be changed for improving, their performance without notice in the parts list. So, if you need the latest parts information, please refer to PPL(Parts Price List) in Service information Center(<http://svc.dwe.co.kr>)

DISASSEMBLY AND ASSEMBLY

KOC-985T

- (1) Remove a screw which secure the control panel assembly to the oven front plate.
At the same time, draw forward the control panel assembly from the oven front plate.
- (2) Remove the dial knob.
- (3) Remove ten screws which secure the main and sub PCB assembly to control panel.
- (4) Remove buttons.
- (5) Remove the window display.

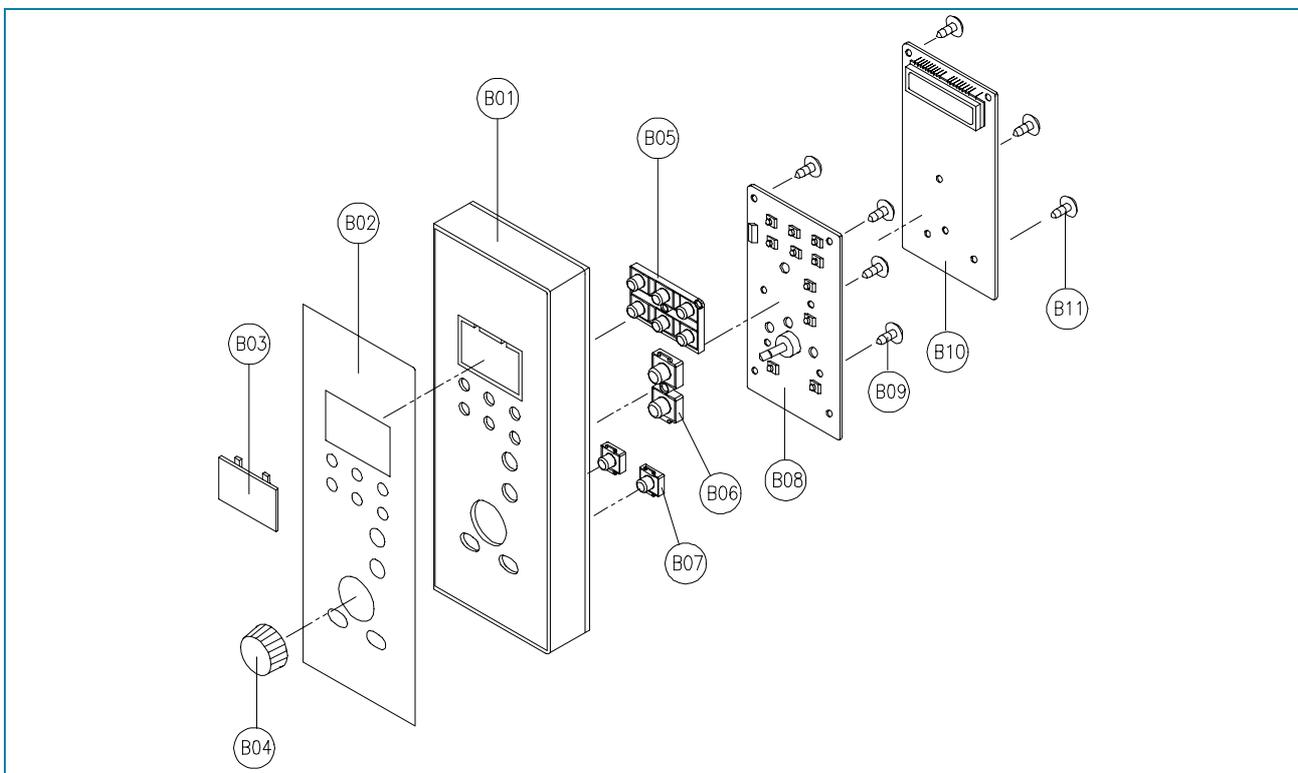
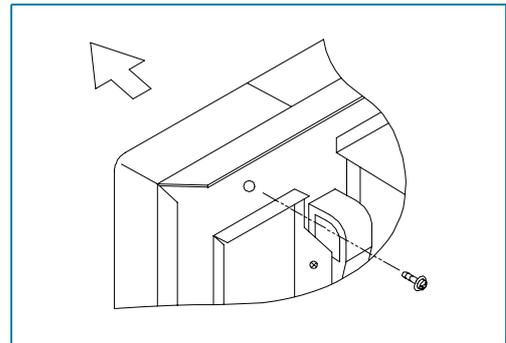

REF NO.	PART CODE	PART NAME	DESCRIPTION	QTY	REMARK
B01	3516719210	CONTROL-PANEL	ABS XR-401	1	
B02	3511603100	DECORATOR C-PANEL	STS304 T0.6 H/L	1	
B03	3515501400	WINDOW DISPLAY	PMMA IF-850	1	SMOG
B04	3513404620	KNOB VOLUME	ABS XR-401	1	COATING
B05	3516905120	BUTTON FUNCTION	ABS XR-401	1	COATING
B06	3516907200	BUTTON FUNCTION	ABS XR-401	1	COATING
B07	3516906320	BUTTON FUNCTION	ABS XR-401	2	COATING
B08	PKBPM5YB00	PCB SUB AS	KOC-984T	1	
B10	PKMP5YB00	PCB MAIN AS	KOC-984T10S	1	
			KOC-984T20S		
B11	7122401211	SCREW TAPPING	T2S TRS 4x12 MFZN	4	

✓ **Caution:** In this Service Manual, some parts can be changed for improving, their performance without notice in the parts list. So, if you need the latest parts information, please refer to PPL(Parts Price List) in Service information Center(<http://svc.dwe.co.kr>)

DISASSEMBLY AND ASSEMBLY

7. To remove door assembly

- (1) Remove two screws which secure the stopper hinge top.
- (2) Remove the door assembly from top plate of cavity.
- (3) Reverse the above steps for reassembly.

NOTE

After replacing the door assembly, perform a check of correct alignment with the hinge and cavity front plate.

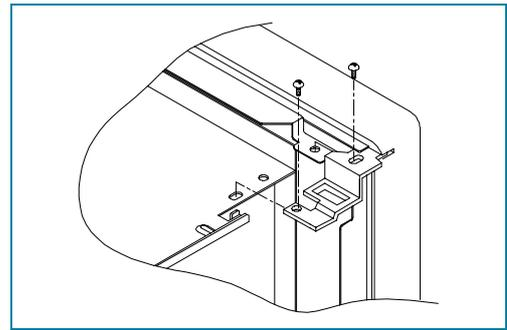

8. To remove door parts

KOC-972T, KOC-982T

- (1) Remove the gasket door.
- (2) Remove the door seal assy.
- (3) Remove the hook and spring.
- (4) Remove the barrier-screen *o.
- (5) Remove two screws.
- (6) Remove the handle from the frame door.

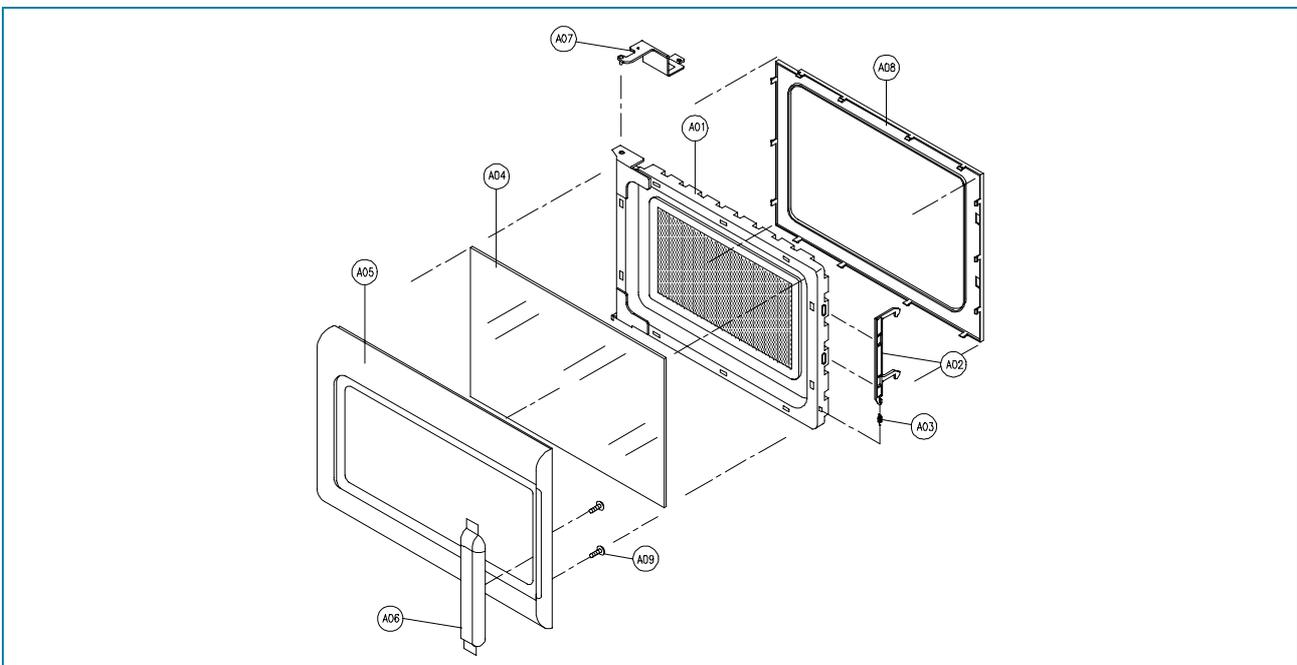

REF. NO.	PART CODE	PART NAME	DESCRIPTION	QTY	REMARK
A01	3511708400	DOOR SEAL AS	KOC-971C0S	1	
A02	3513101100	HOOK	POM	1	
A03	3515101300	SPRING HOOK	PW1	1	
A04	3517004030	BARRIER-SCREEN *O	TEMPERED GLASS T3.2	1	
A05	3512203360	FRAME DOOR	ABS XR-401	1	
A06	3512601430	HANDLE DOOR	ABS XR-401	1	
A07	3515203600	STOPPER HINGE *T AS	KOC-970T1S	1	
A08	3512300800	GASKET DOOR	PBT	1	
A09	7621301011	SCREW TAPPING	T2S PAN 3x10 MFZN	2	

✓ **Caution:** In this Service Manual, some parts can be changed for improving, their performance without notice in the parts list. So, if you need the latest parts information, please refer to PPL(Parts Price List) in Service information Center(<http://svc.dwe.co.kr>)

DISASSEMBLY AND ASSEMBLY

KOC-983T

- (1) Remove the gasket door.
- (2) Remove the door seal ass'y.
- (3) Remove the hook and spring.
- (4) Remove the barrier-screen *o.

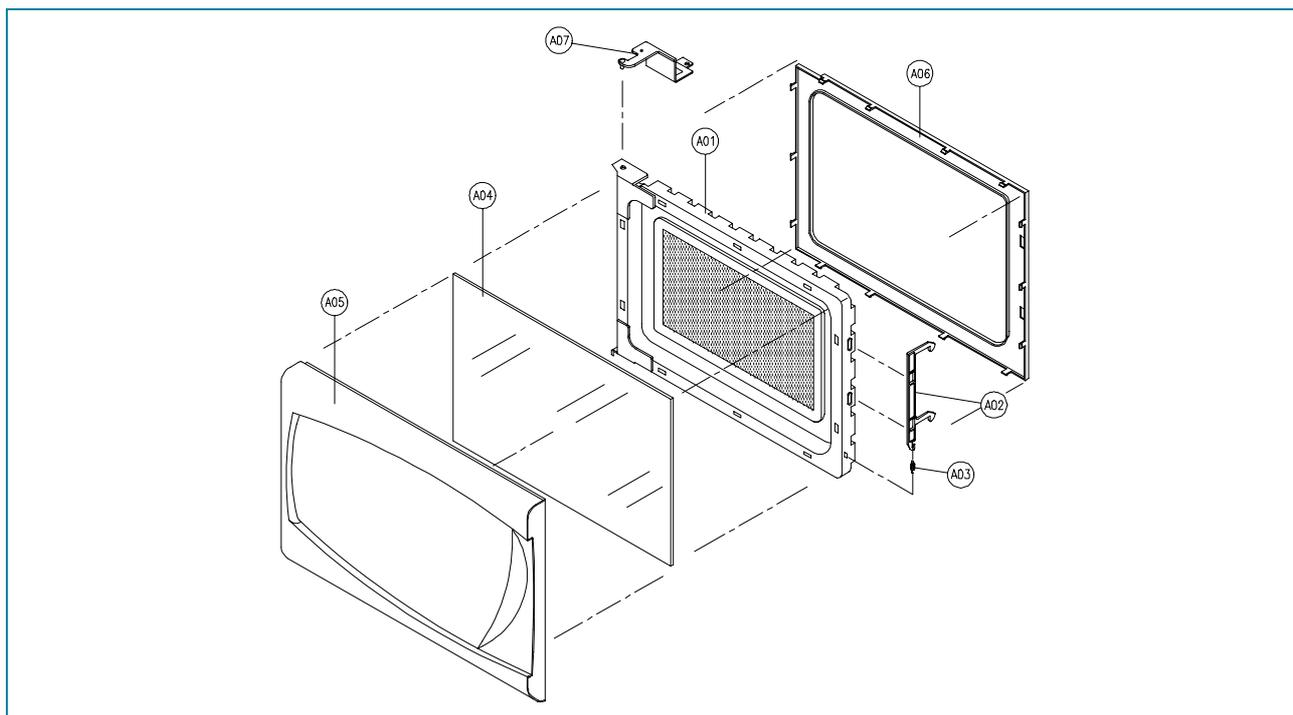

REF. NO.	PART CODE	PART NAME	DESCRIPTION	QTY	REMARK
A01	3511708400	DOOR SEAL AS	KOC-971C0S	1	
A02	3513101100	HOOK	POM	1	
A03	3515101300	SPRING HOOK	PW1	1	
A04	3517004030	BARRIER-SCREEN *O	TEMPERED GLASS T3.2	1	
A05	3512204010	FRAME DOOR	ABS XR-401	1	
A06	3512300800	GASKET DOOR	PBT	1	
A07	3515203600	STOPPER HINGE *T AS	KOC-970T1S	1	

✓ **Caution:** In this Service Manual, some parts can be changed for improving, their performance without notice in the parts list. So, if you need the latest parts information, please refer to PPL(Parts Price List) in Service information Center(<http://svc.dwe.co.kr>)

DISASSEMBLY AND ASSEMBLY

KOC-984T, KOC-985T

- (1) Remove the gasket door.
- (2) Remove a screw holding the handle.
- (3) Remove the handle from the frame door.
- (4) Remove the door seal ass'y.
- (5) Remove the hook and spring.
- (6) Remove the barrier-screen *o.

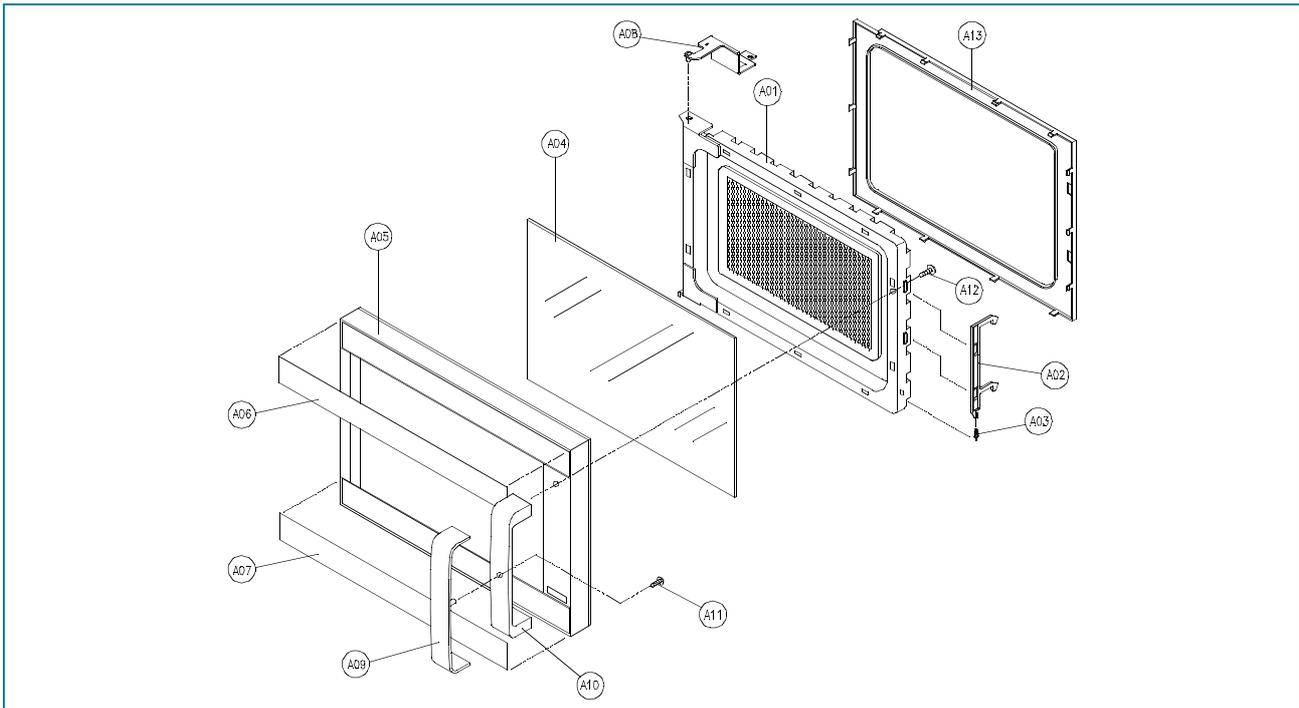

REF. NO.	PART CODE	PART NAME	DESCRIPTION	QTY	REMARK
A01	3511708400	DOOR SEAL AS	KOC-971C0S	1	
A02	3513101100	HOOK	POM	1	
A03	3515101300	SPRING HOOK	PW1	1	
A04	3517004080	BARRIER-SCREEN *O	TEMPERED GLASS T3.2	1	MIRROR
A05	3512204000	FRAME DOOR	ABS XR-401	1	
A06	3511603200	DECORATOR DOOR *T	STS304 T0.6 H/L	1	
A07	3511603300	DECORATOR DOOR *U	STS304 T0.6 H/L	1	
A08	3515203600	STOPPER HINGE *T AS	KOC-970T	1	
A09	3512602400	HANDLE DOOR *T AS	ABS XR-401 WOOD GRAIN	1	KOC-984T
	3512602410	HANDLE DOOR *T AS	ABS XR-401 SILVER COAT	1	KOC-985T
A10	3512602300	HANDLE DOOR *U	ABS XR-401	1	
A11	7621300811	SCREW TAPPING	T2S PAN 3x8 MFZN	1	
A12	7122401211	SCREW TAPPING	T2S TRS 4x12 MFZN	1	
A13	3512300800	GASKET DOOR	PBT	1	

9. Method to reduce the gap between the door seal and the oven front surface.

(1) To reduce gap located on part 'A'

- Loosen two screws on stopper hinge top, and then push the door to contact the door seal to oven front surface.
- Tighten two screws.

(2) To reduce gap located on part 'B'

- Loosen two screws on stopper hinge under, and then push the door to contact the door seal to oven front surface.
- Tighten two screws.

(3) To reduce gap located on part 'C'

- Loosen a screw on interlock switch assembly located bottom of oven body.
- Draw the interlock switch assembly inward as possible to engage with hook on the door bottom.
- Tighten a screw.

(4) To reduce gap located on part 'D'

- Loosen a screw on interlock switch assembly located top of oven body.
- Following steps are same as step (3).

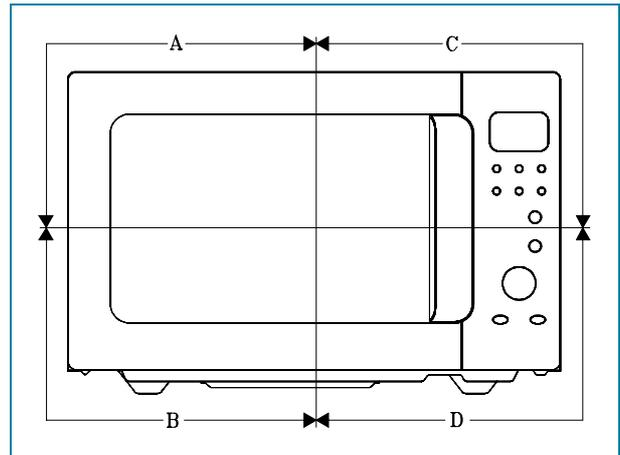

NOTE

Small gap may be acceptable if the microwave leakage does not exceed $1\text{mW}/\text{cm}^2$.

NOTE

The door on a microwave oven is designed to act as an electronic seal preventing the leakage of microwave energy from the oven cavity during the cook cycle. This function does not require that the door be air-tight, moisture (condensation) tight or light-tight. Therefore, the occasional appearance of moisture, light or the sensing of gentle warm air movement around the oven door is not abnormal and do not of themselves, indicate a leakage of microwave energy from the oven cavity. If such were the case, your oven could not be equipped with a vent, the very purpose of which is to exhaust the vapor-laden air from the oven cavity.

10. To remove motor syncro and under heater

- (1) Cut the syncro motor cover parts from the base plate.
- (2) Remove two screws which secure the motor syncro and supporter to bracket syncro motor.
- (3) Remove two screws and under heater assembly in cavity

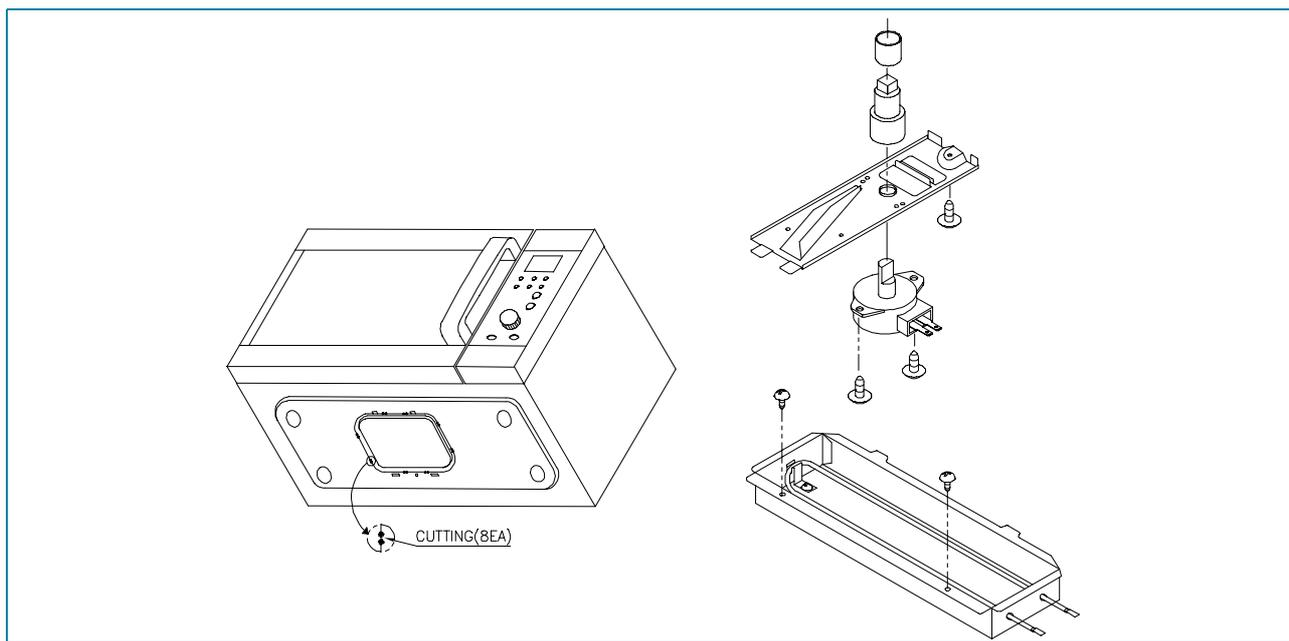

11. To remove grill heater assembly

KOC-972T

- (1) Remove a nut which secure the heater holder inserting the wire of grill heater to side plate.
- (2) Remove two nuts and a screw which secure the heater bracket to grill heater.
- (3) Remove two heater brackets.
- (4) Pull the heater holder inward and then remove the grill heater.
- (5) Reverse the above steps for reassembly.

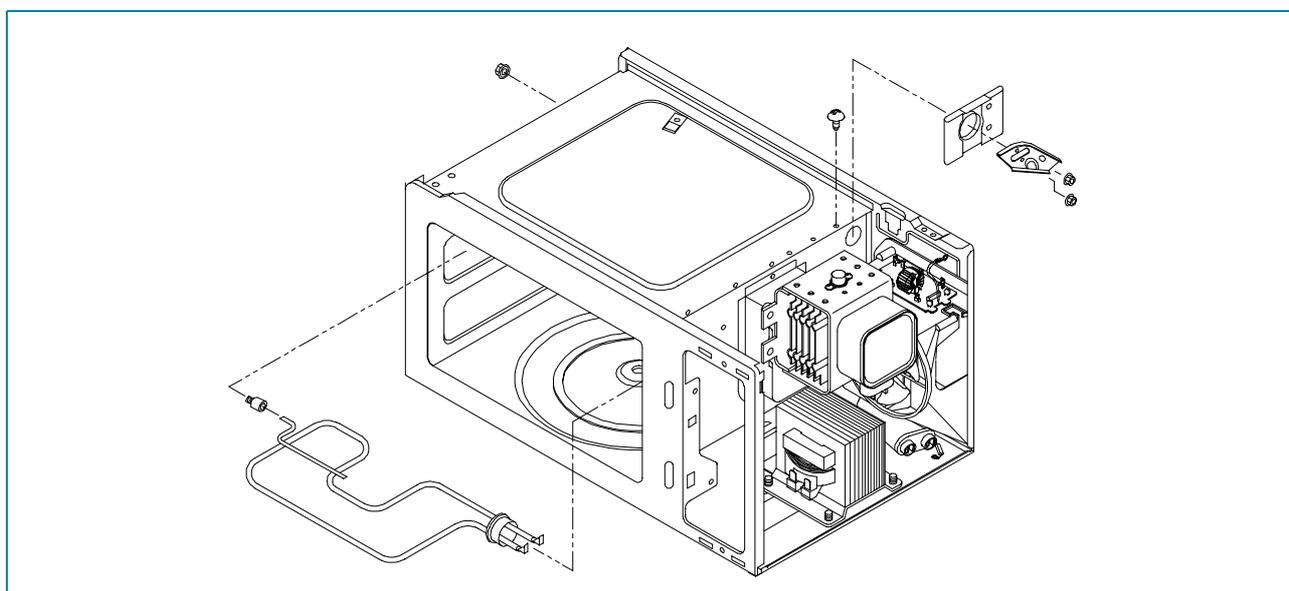

KOC-982T,KOC-983T,KOC-984T,KOC-985T

- (1) Remove two screws which secure the cover insulator *t to top plate.
- (2) Remove the harness between heaters.
- (3) Remove two screws for removing heater brackets.
- (4) Remove heaters.
- (5) Reverse the above steps for reassembly.

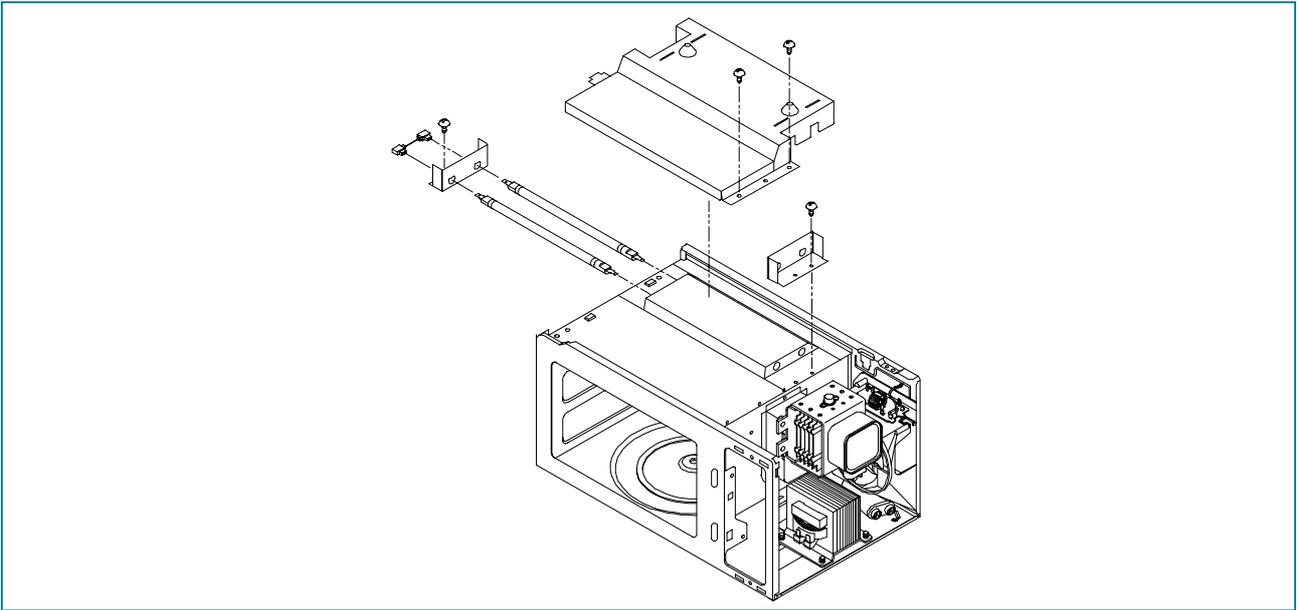
**12. To remove convection part assembly (KOC-982T,KOC-983T,KOC-984T,KOC-985T only)**

- (1) Remove cover *b and cover insulator *b protecting convection part assembly. - release two lances of cover insulator *b.
- (2) Remove four screws which secure the convection part assembly to the cavity rear plate.
- (3) Remove a nut holding the convection fan and the pipe.
- (4) Remove two screws which secure the bracket motor to cover insulator.
- (5) Remove the cooling fan.
- (6) Remove two screws which secure the motor shaded pole to the bracket motor.
- (7) Reverse the above steps for reassembly.

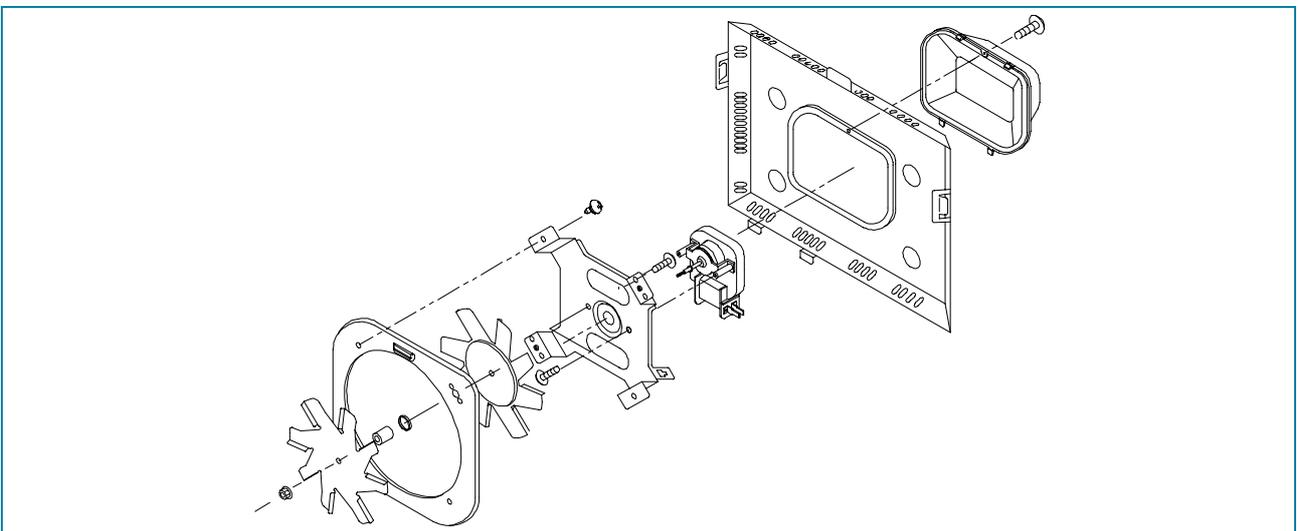

INTERLOCK MECHANISM AND ADJUSTMENT

The door lock mechanism is a device which has been specially designed to completely eliminate microwave radiation when the door is opened during operation, and thus to perfectly prevent the danger resulting from the leakage of microwave.

1. Primary interlock switch

When the door is closed, the hook locks the oven door. If the door is not closed properly, the oven will not operate.

When the door is closed, the hook pushes the button of the microswitch.

Then the button of the primary interlock switch bring it under "ON" condition.

2. Secondary interlock switch, door open monitor switch and interlock monitor switch

When the door is closed, the hook pushes the latch lever downward.

The latch lever presses the button of the interlock monitor switch to bring it under "OFF" condition and

presses the button of the secondary interlock switch and door open monitor switch to bring it under "ON" condition.

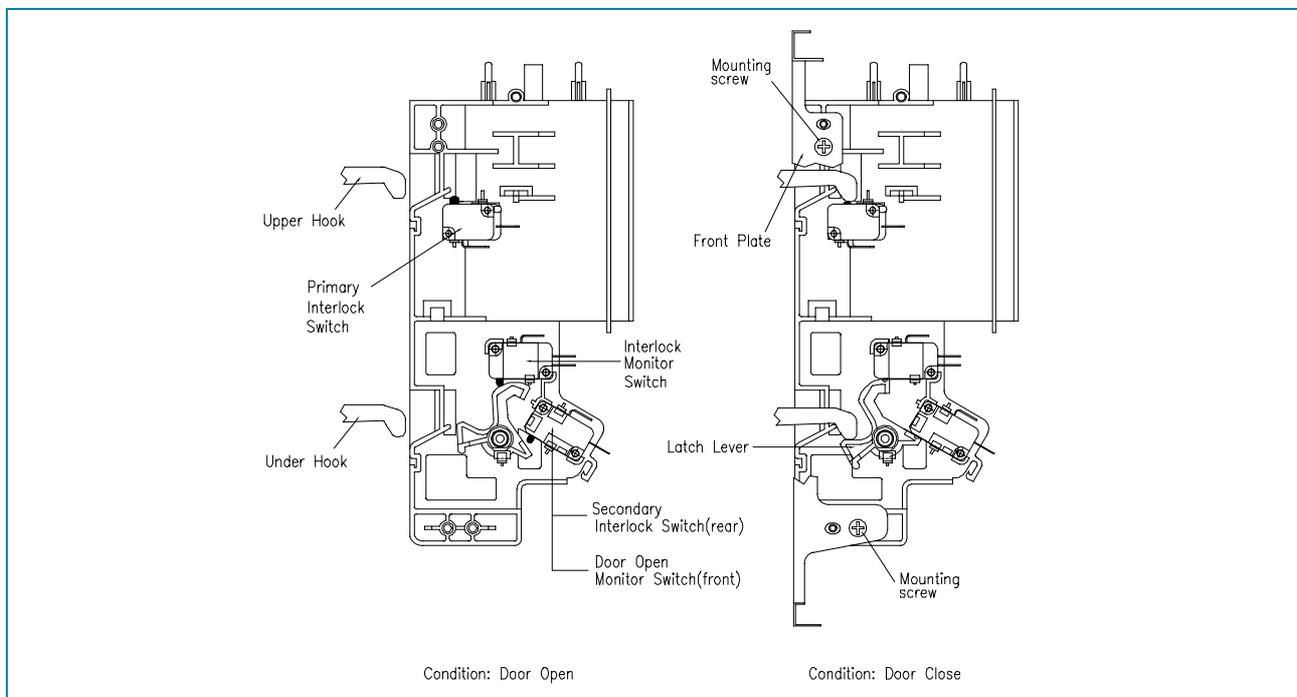

ADJUSTMENT

Interlock monitor switch

When the door is closed, the interlock monitor switch should be opened before other switches are closed.

When the door is opened, the interlock monitor switch should be closed after other switches are opened.

3. Adjustment steps

- (1) Loosen two mounting screws.
- (2) Adjust interlock switch assembly position.
- (3) Make sure that latch lever moves smoothly after adjustment is completed.
- (4) Tighten completely two mounting screws.

NOTE

Microwave emission test should be performed after adjusting interlock mechanism.

If the microwave emission exceed $4\text{mW}/\text{cm}^2$, readjust interlock mechanism.

TROUBLE SHOOTING GUIDE

Following the procedures below to check if the oven is defective or not.

1. Check grounding before checking trouble.
2. Be careful of the high voltage circuit.
3. Discharge the high voltage capacitor.
4. When checking the continuity of the switches, fuse or high voltage transformer, disconnect one lead wire from these parts and then check continuity with the AC plug removed. To do otherwise may result in a false reading or damage to your meter.

NOTE

When electric parts are checked, be sure the power cord is not inserted into the wall outlet.
Check wire harness, wiring, and connected of the terminals and power cord before check parts listed below.

(TROUBLE 1) Oven does not operate at all; any inputs can not be accepted.

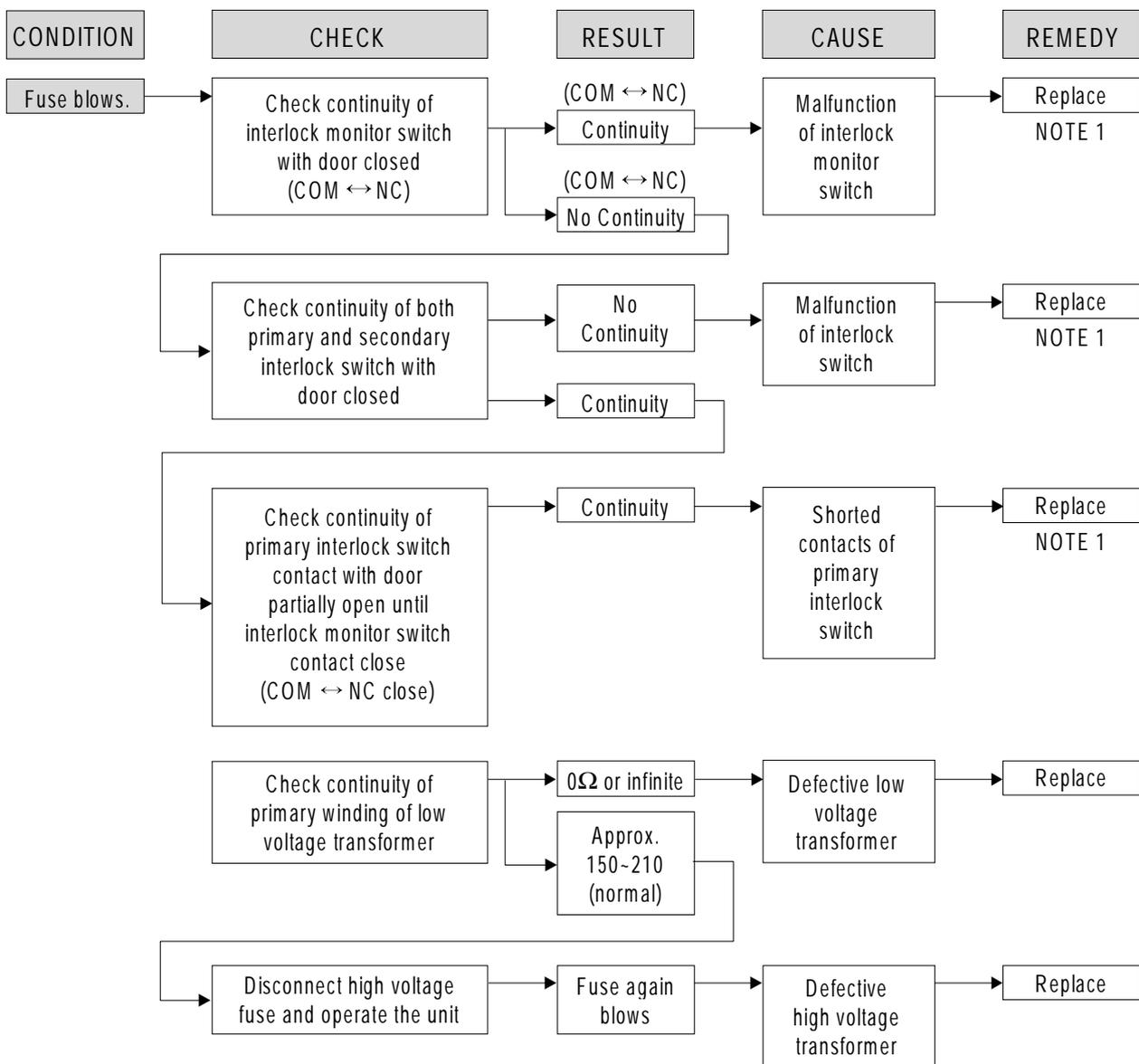

CONDITION	CHECK	RESULT	CAUSE	REMEDY
Outlet has proper voltage Fuse does not blow.	Check continuity of magnetron	No Continuity	Defective magnetron	Replace
	Check continuity of noise filter board	No Continuity	Defective noise filter board	Replace
	Check continuity of power supply cord	No Continuity	Open power supply cord	Adjust
		Normal	Defective touch control circuit	Adjust

NOTE

All these switches must be replaced at the same time, please refer to (7. Interlock Mechanism and Adjust) for adjustment instructions.

(TROUBLE 2) Grill heater (top heater) is not heated; Food will not become hot.

CONDITION	CHECK	RESULT	CAUSE	REMEDY
Grill heater is not heated.	Check continuity of primary interlock switch	No Continuity	Malfunction of primary interlock switch	Adjust or Replace
	Check continuity of secondary interlock switch	No Continuity	Malfunction of secondary interlock switch	Adjust or Replace
	Check continuity of heater	No Continuity	Defective heater	Replace
	Check D.C. voltage being supplied to RELAY (RY2) coil	0 V	Defective touch control circuit	Replace
		Approx 12 VDC	Faulty contacts of RELAY (RY2) or open relay coil	Replace

(TROUBLE 3) No microwave oscillation even though fan motor rotates.

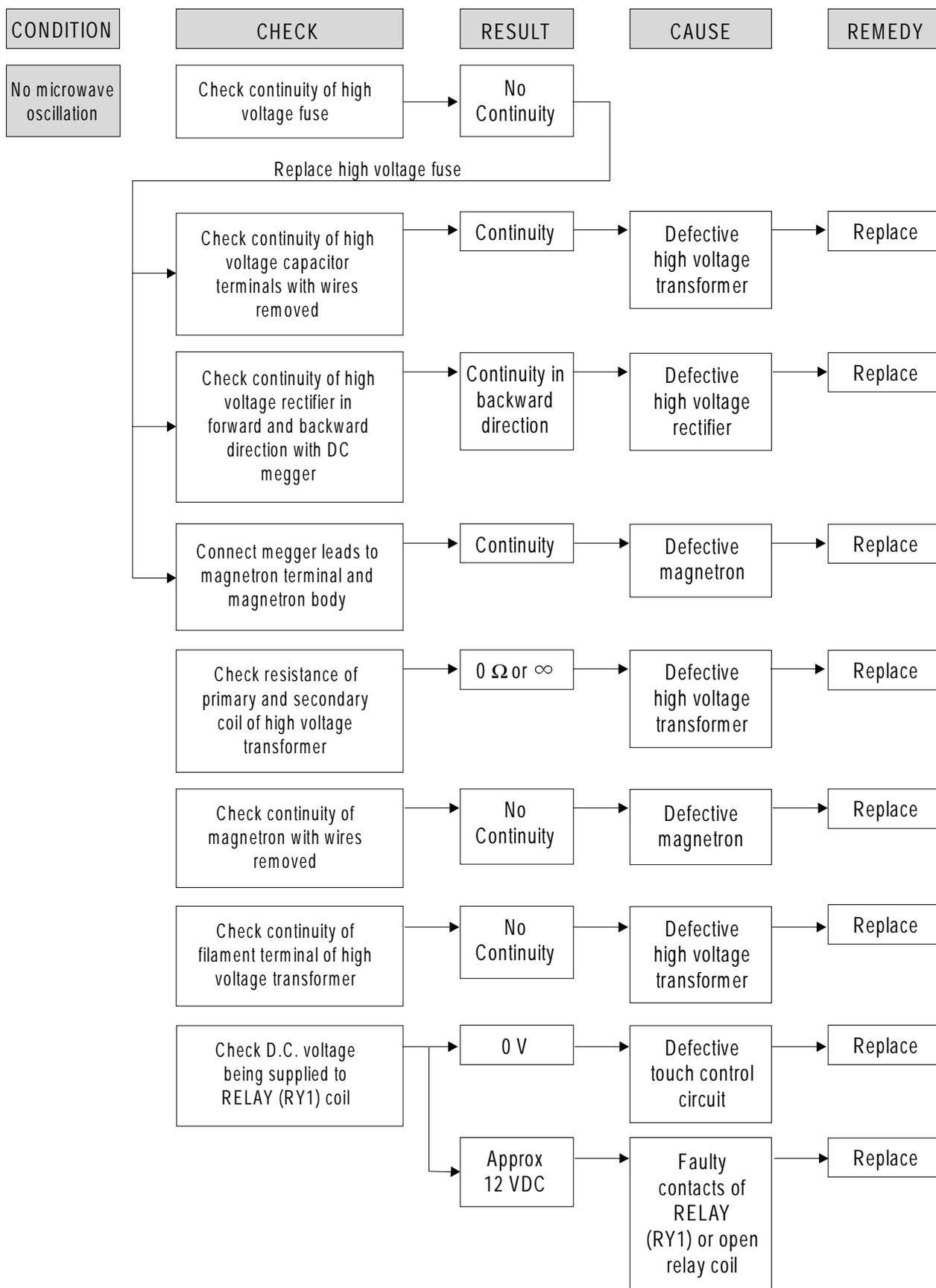

(TROUBLE 4) Display shows all figures selected, but oven does not start cooking, even though desired program and time are set and start pad is tapped.

CONDITION	CHECK	RESULT	CAUSE	REMEDY
Turn table motor and oven lamp do not turn on	Check continuity of primary interlock switch	No Continuity	Malfunction of primary interlock switch	Adjust or replace
	Check continuity of secondary interlock and D.O.M. switch	No Continuity	Malfunction of secondary interlock and D.O.M. switch	Adjust or replace
	Check D.C. voltage being supplied to RELAY (RY3) coil	0 V	Defective touch control circuit	Replace
		Approx. 12 VDC	Faulty contacts of RELAY (RY3) or open relay coil	Replace

(TROUBLE 5) 1) Under heater is not heated; Food will not become hot.
2) Convection motor does not rotate.

CONDITION	CHECK	RESULT	CAUSE	REMEDY
1) Under heater is not heated. 2) Convection fan and motor does not rotate.	Check continuity of primary interlock switch	No Continuity	Malfunction of primary interlock switch	Adjust or replace
	Check continuity of secondary interlock switch	No Continuity	Malfunction of secondary interlock switch	Adjust or replace
	Check continuity of heater (motor)	No Continuity	Defective heater(motor)	Replace
	Check D.C. voltage being supplied to RELAY (RY5) coil	0 V	Defective touch control circuit	Replace
		Approx. 12 VDC	Faulty contacts of RELAY (RY5) or open relay coil	Replace

(TROUBLE 6) The following visual conditions indicate a probable defective touch control circuit or button P.C.B. assembly.

1. Incomplete segments
 - (1) Segments missing
 - (2) Partial segments missing
 - (3) Digit flickering other than normal fluorescent slight flickering
 - (4) 0 does not display when power is on.
2. A distinct change in the brightness of one or more numbers exists in the display.
3. One or more digits in the display are not on when they should be.
4. Display indicates a number different from one touched. (for example, even if one touched 5, 3 appears in the display.)
5. Specific numbers (for example, 2 or 3) do not display when the button is touched.
6. Display does not count down or up with time cooking or clock operation.
7. Oven is programmable and cooks normally but no display shows.
8. Display obviously jumps in time while counting down.
9. Display counts down noticeably too fast while cooking.
10. Display does not show the time of day when clear button is touched.
11. Oven lamp and turntable motor do not stop although cooking is finished.

Check if the RELAY (RY3) contacts close and if they are close, replace touch control circuit.

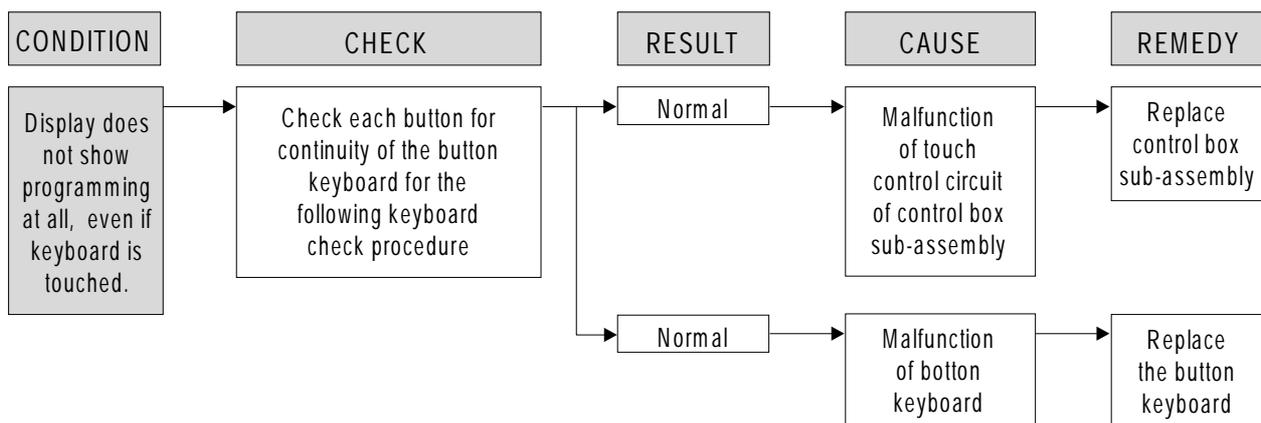
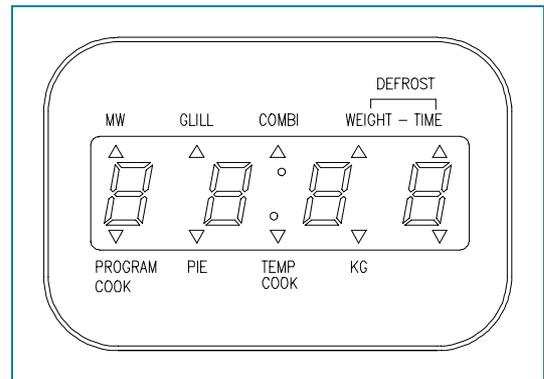

NOTE

Before following the particular steps listed above in the trouble shooting guide for the button keyboard's failure, please check for the continuity of each wire-harness between the button keyboard and P.C.B. assembly.

BUTTON KEYBOARD CHECK PROCEDURE

1. Type of button names

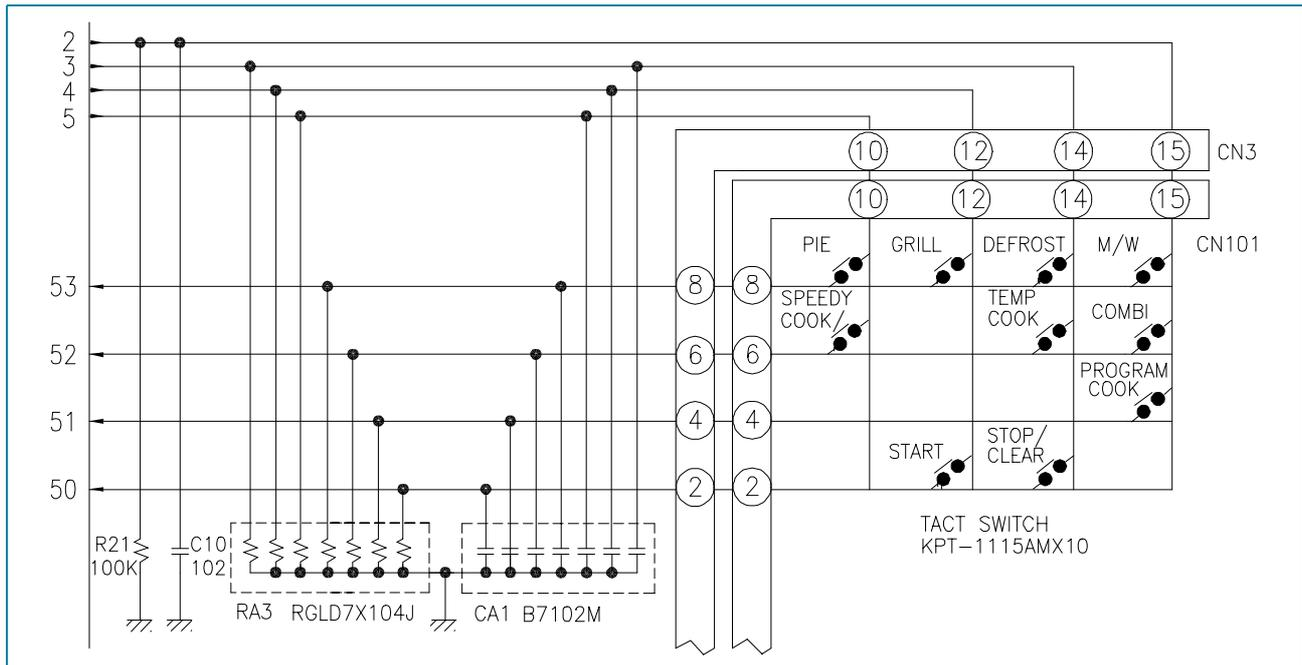

(key matrix and circuit diagram)

The tact switch keyboard consists of 10 keys which configurations are described above.

2. Key check procedure

To determine if the tact switch keyboard is defective or not, check the continuity of each button(key) contacts with a multimeter.

(1) PROGRAM COOK	button : between 4 and 15
(2) TIME DEFROST	button : between 8 and 14
(3) WEIGHT DEFROST	button : between 8 and 14
(4) COMBI	button : between 6 and 15
(5) GRILL	button : between 8 and 12
(6) M/W	button : between 8 and 15
(7) PIE	button : between 8 and 10
(8) SPEEDY COOK	button : between 6 and 10
(9) TEMP	button : between 6 and 14
(10) START/CLOCK	button : between 2 and 12
(11) STOP/CLEAR	button : between 2 and 14

MEASUREMENT AND TEST

1. MEASUREMENT OF THE MICROWAVE POWER OUTPUT

Microwave output power can be checked by indirectly measuring the temperature rise of a certain amount of water exposed to the microwave as directed below.

PROCEDURE

- Microwave power output measurement is made with the microwave oven supplied at rated voltage and operated at its maximum microwave power setting with a load of 1000 ± 5 cc of potable water.
- The water is contained in a cylindrical borosilicate glass vessel having a maximum material thickness of 3 mm and an outside diameter of approximately 190 mm.
- The oven and the empty vessel are at ambient temperature prior to the start of the test.
The initial temperature of the water is 10 ± 2 °C (50 ± 3.6 °F).
It is measured immediately before the water is added to the vessel.
After addition of the water to the vessel, the load is immediately placed on the center of the shelf, which is in the lowest normal position.

- Microwave power is switched on.

- Heating time should be exactly **A** seconds.

Heating time is measured while the microwave generator is operating at full power.

The filament heat-up time for magnetron is not included.

- The initial and final temperature of water is selected so that the maximum difference between the ambient and final water temperature is 5K.

- The microwave power output P in watts is calculated from the following formula:

$$P = 4187 \times \Delta T/t$$

- ΔT is difference between initial and ending temperature.
- t is the heating time.

The power measured should be **B** (refer to Specifications) $W \pm 10.0$ %.

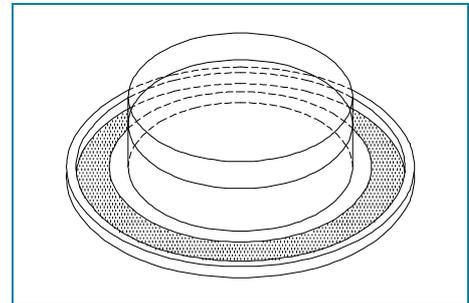

CAUTION

- Water load should be measured exactly to 1 liters.
- Input power voltage should be exactly specified voltage (Refer to SPECIFICATIONS).
- Ambient temperature should be 20 ± 2 °C (68 ± 3.6 °F)

Heating time for power output:

A(second)	70	64	60	56	52	49	47	44	42	40	38
B(W)	600	650	700	750	800	850	900	950	1000	1050	1100

2. ELECTRICAL CONTINUITY CHECK OF INTERLOCK SWITCH

NOTE

Remove the power plug from the wall receptacle before testing.

PROCEDURE

1. Primary interlock switch
 - (1) Disconnect two connectors from primary interlock switch.
 - (2) Connect the ohm-meter leads between the terminals of the primary interlock switch.
2. Read the value of resistance between the terminals of the switch, when the door is opened, and when the door is closed.
3. Secondary interlock switch
 - (1) Disconnect two connectors from secondary interlock switch.
 - (2) Connect the ohm-meter leads between the terminals of the secondary interlock switch.
 - (3) Read the value of resistance between the terminals of the switch, when the door is opened, and when the door is closed.
3. Monitor interlock switch
 - (1) Disconnect the lead wire connecting the primary interlock switch and interlock monitor switch from primary interlock switch terminal.
 - (2) Connect the ohm-meter leads between the lead wire connector disconnected as item1 and the power supply neutral plug pin.
 - (3) Read the value of resistance between the lead wire connector and the power supply neutral plug pin, when the oven door is opened, and when the oven door is closed.

JUDGEMENT

- The value of resistance should be applied to the value specified below.

Switch	Door Open	Door Close
Primary interlock switch	∞	0
Secondary interlock switch	∞	0
Interlock monitor circuit	0	∞

- When value obtained is not acceptable, the switch should be replaced or adjusted again.

3. MICROWAVE RADIATION TEST

WARNING

Make sure to check the microwave leakage before and after repair or adjustment.
 Always start measuring of an unknown field to assure safety for operating personnel from microwave energy.
 Do not place your hands into any suspected microwave radiation field unless the safe density level is known.
 Care should be taken not to place the eyes in direct line with the source of microwave energy.
 Slowly approach the unit under test until the radiometer reads an appreciable microwave leakage from the unit under the test.

PROCEDURE

1. Prepare Microwave Energy Survey Meter, 600cc glass beaker, and glass thermometer 100°C (212°F).
2. Pour 275cc ± 15cc of tap water initially at 20 ± 5 °C (68 ± 9°F) in the 600 cc glass beaker with an inside diameter of approx. 95 mm(3.5 in.).
3. Place it at the center of the tray and set it in a cavity.
4. Close the door and operate the oven.
5. Measure the leakage by using Microwave Energy Survey Meter with dual ranges, set to 2450MHz.
 - Measured radiation leakage must not exceed the value prescribed below.
 Leakage for a fully assembled oven with door normally closed must be less than 4mW/cm².
 - When measuring the leakage, always use the 5 cm (2 in.) space cone with probe.
 Hold the probe perpendicular to the cabinet and door.
 Place the space cone of the probe on the door, cabinet, door seem, door viewing screen, the exhaust air vents and the suction air vents.
 - Measuring should be in a counter-clockwise direction at a rate of 1 in./sec.
 If the leakage of the cabinet door seem is unknown, move the probe more slowly.
 - When measuring near a corner of the door, keep the probe perpendicular to the areas making sure the probe end at the base of the cone does not get closer than 2 in. from any metal.
 If it does not, erroneous reading may result.

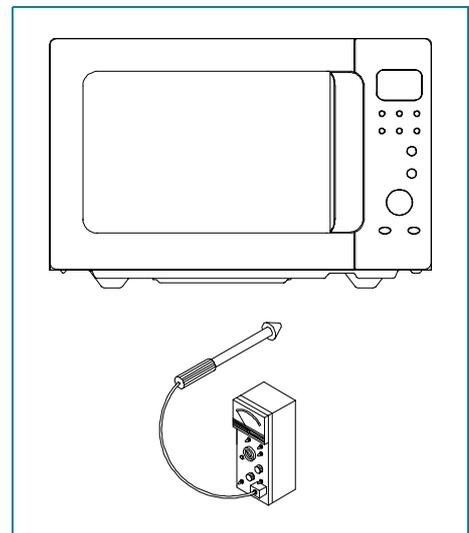

4. COMPONENT TEST PROCEDURE

- High voltage is present at the high voltage terminal of the high voltage transformer during any cooking cycle.
- It is neither necessary nor advisable to attempt measurement of the high voltage.
- Before touching any oven components or wiring, always unplug the oven from its power source and discharge the capacitor.

1. High voltage transformer

- (1) Remove connections from the transformer terminals and check continuity.
- (2) Normal readings should be as follows :
 - Secondary winding ... Approx. $100\ \Omega \pm 10\%$
 - Filament winding ... Approx. $0.1\ \Omega$
 - Primary winding ... Approx. $1.5\ \Omega$

2. High voltage capacitor

- (1) Check continuity of capacitor with meter on the highest OHM scale.
- (2) A normal capacitor will show continuity for a short time, and then indicate $9M\ \Omega$ once the capacitor is charged.
- (3) A shorted capacitor will show continuous continuity.
- (4) An open capacitor will show constant $9M\ \Omega$
- (5) Resistance between each terminal and chassis should be infinite.

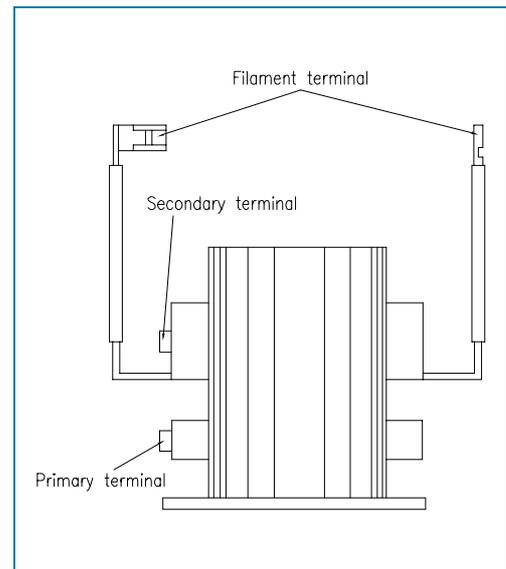

3. High voltage diode

- (1) Isolate the diode from the circuit by disconnecting the leads.
- (2) With the ohmmeter set on the highest resistance scale measure the resistance across the diode terminals. Reverse the meter leads and again observe the resistance reading. Meter with 6V, 9V or higher voltage batteries should be used to check the front-back resistance of the diode, otherwise an infinite resistance may be read in both directions. A normal diode's resistance will be infinite in one direction and several hundred $k\ \Omega$ in the other direction.

4. Magnetron

For complete magnetron diagnosis, refer to "Measurement of the Microwave Output Power." Continuity checks can only indicate an open filament or a shorted magnetron.

To diagnose for an open filament or a shorted magnetron,

- (1) Isolate magnetron from the circuit by disconnecting the leads.
- (2) A continuity check across magnetron filament terminals should indicate $0.1\ \Omega$ or less.
- (3) A continuity check between each filament terminal and magnetron case should read open.

5. Fuse

If the fuse in the primary and monitor switch circuit is blown when the door is opened, check the primary and monitor switch before replacing the blown fuse.

In case the fuse is blown by an improper switch operation, replace the defective switch and fuse at the same time.

Replace just the fuse if the switches operate normally.

WIRING DIAGRAM

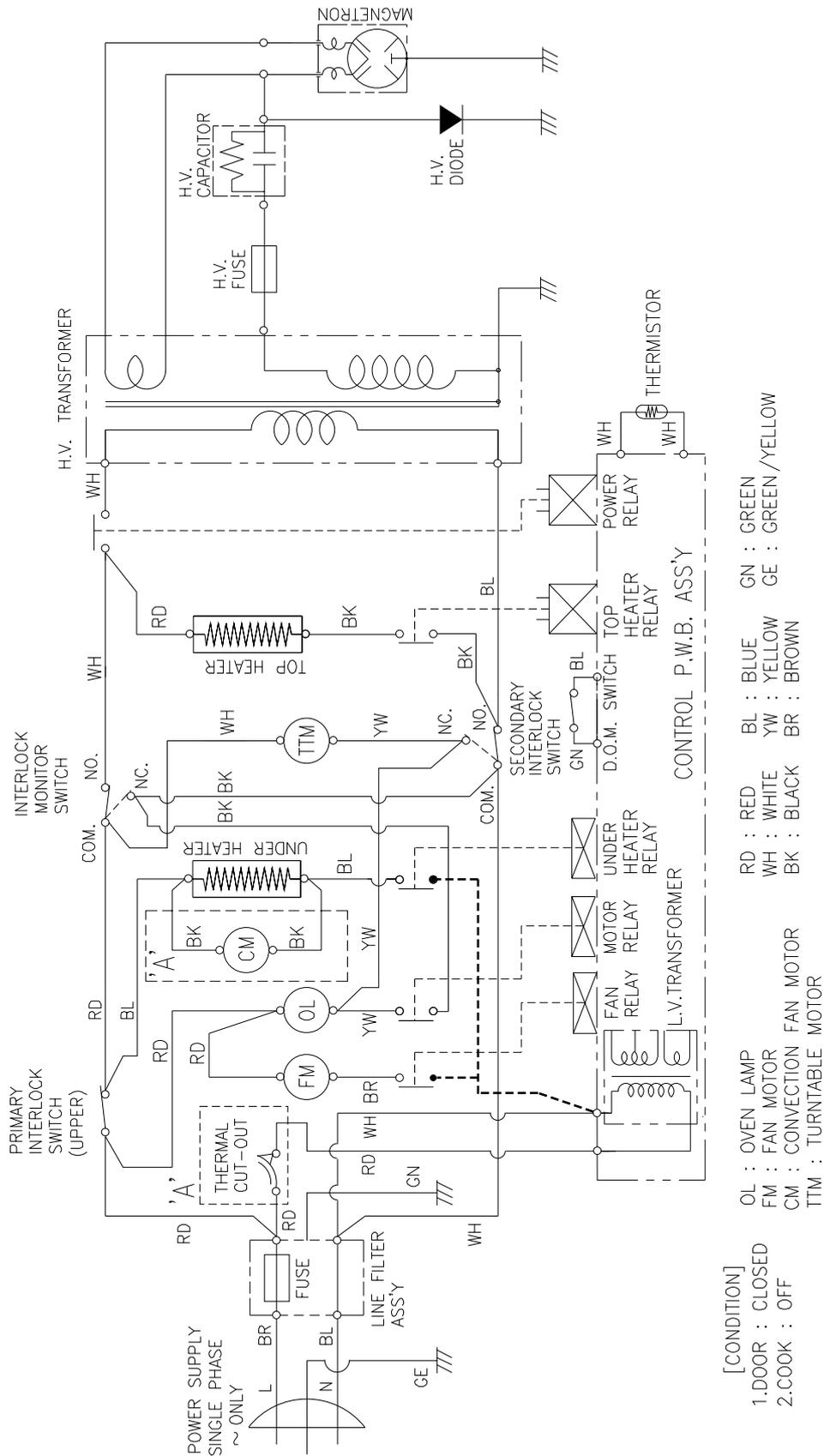

SCHEMATIC DIAGRAM

IDLE CONDITION

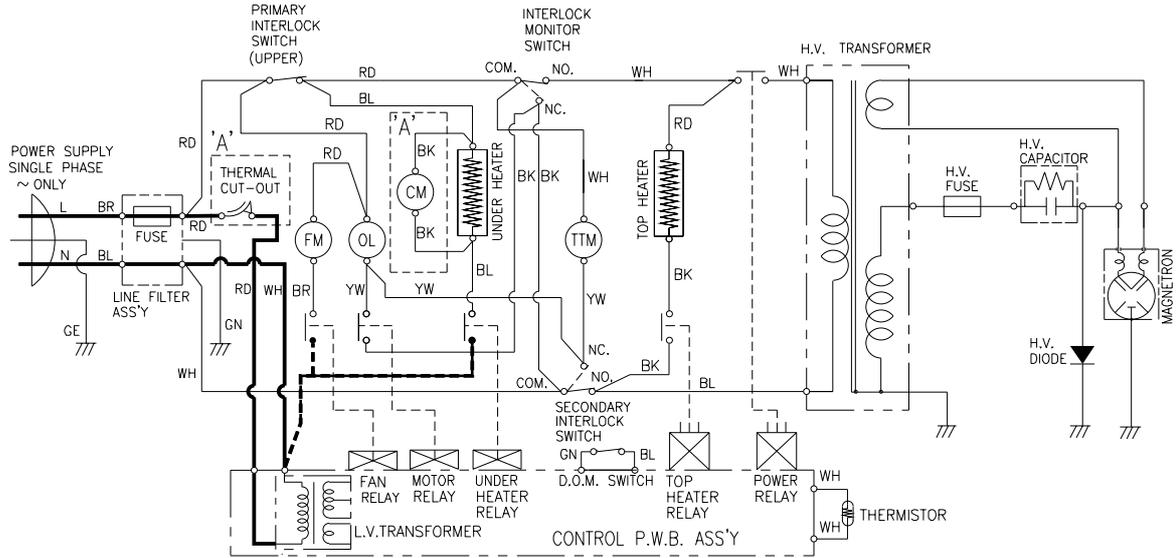

[CONDITION]
 1.DOOR : CLOSED
 2.COOK : OFF

OL : OVEN LAMP	RD : RED	BL : BLUE	GN : GREEN
FM : FAN MOTOR	WH : WHITE	YW : YELLOW	GE : GREEN/YELLOW
CM : CONVECTION FAN MOTOR	BK : BLACK	BR : BROWN	
TTM : TURNTABLE MOTOR			

*EXCEPT [A'] :KOC-972T

*INCLUDING [A'] :KOC-982T/983T/984T/985T

MICROWAVE COOKING CONDITION

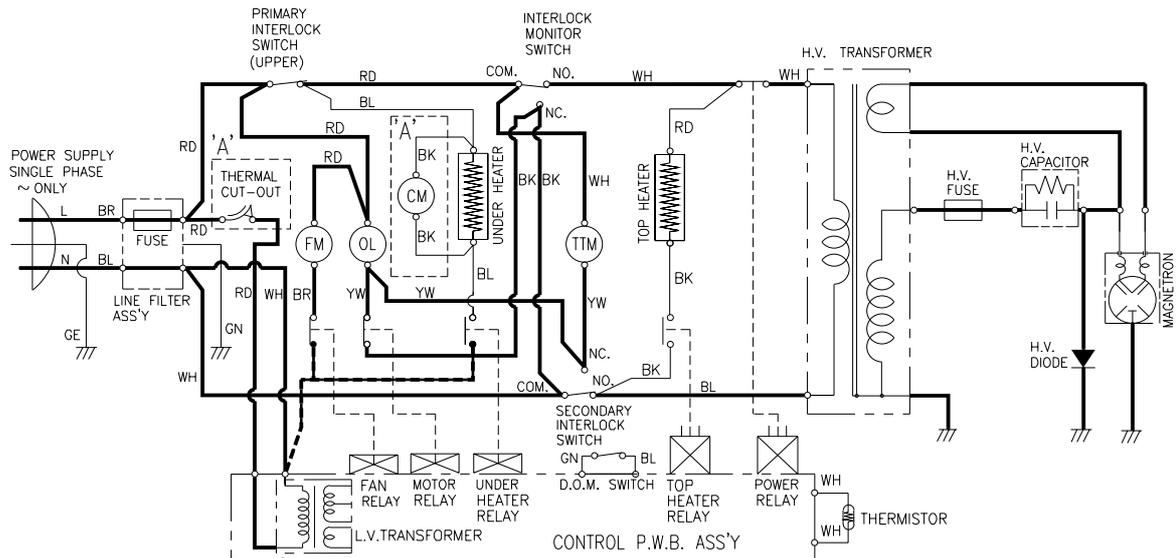

[CONDITION]
 1.DOOR : CLOSED
 2.COOK : OFF

OL : OVEN LAMP	RD : RED	BL : BLUE	GN : GREEN
FM : FAN MOTOR	WH : WHITE	YW : YELLOW	GE : GREEN/YELLOW
CM : CONVECTION FAN MOTOR	BK : BLACK	BR : BROWN	
TTM : TURNTABLE MOTOR			

*EXCEPT [A'] :KOC-972T

*INCLUDING [A'] :KOC-982T/983T/984T/985T

SCHEMATIC DIAGRAM

GRILL COOKING CONDITION

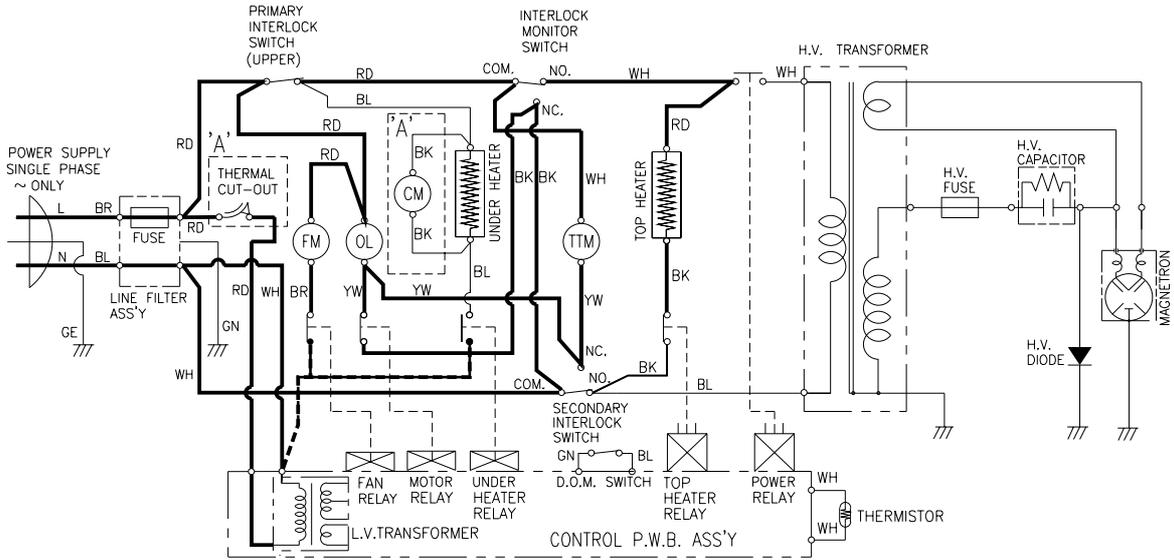

- [CONDITION]
 1.DOOR : CLOSED
 2.COOK : OFF
- OL : OVEN LAMP
 FM : FAN MOTOR
 CM : CONVECTION FAN MOTOR
 TTM : TURNTABLE MOTOR
- RD : RED
 WH : WHITE
 BK : BLACK
 BL : BLUE
 YW : YELLOW
 BR : BROWN
 GN : GREEN
 GE : GREEN/YELLOW

*EXCEPT [A] :KOC-972T
 *INCLUDING [A] :KOC-982T/983T/984T/985T

COMBI COOKING CONDITION

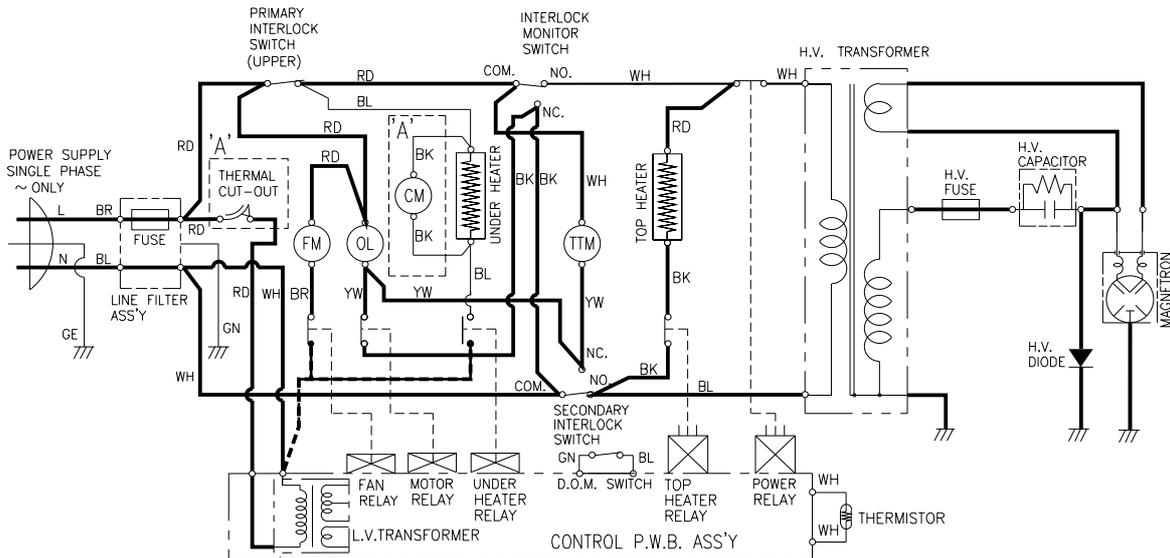

- [CONDITION]
 1.DOOR : CLOSED
 2.COOK : OFF
- OL : OVEN LAMP
 FM : FAN MOTOR
 CM : CONVECTION FAN MOTOR
 TTM : TURNTABLE MOTOR
- RD : RED
 WH : WHITE
 BK : BLACK
 BL : BLUE
 YW : YELLOW
 BR : BROWN
 GN : GREEN
 GE : GREEN/YELLOW

*EXCEPT [A] :KOC-972T
 *INCLUDING [A] :KOC-982T/983T/984T/985T

CONVECTION COOKING CONDITION

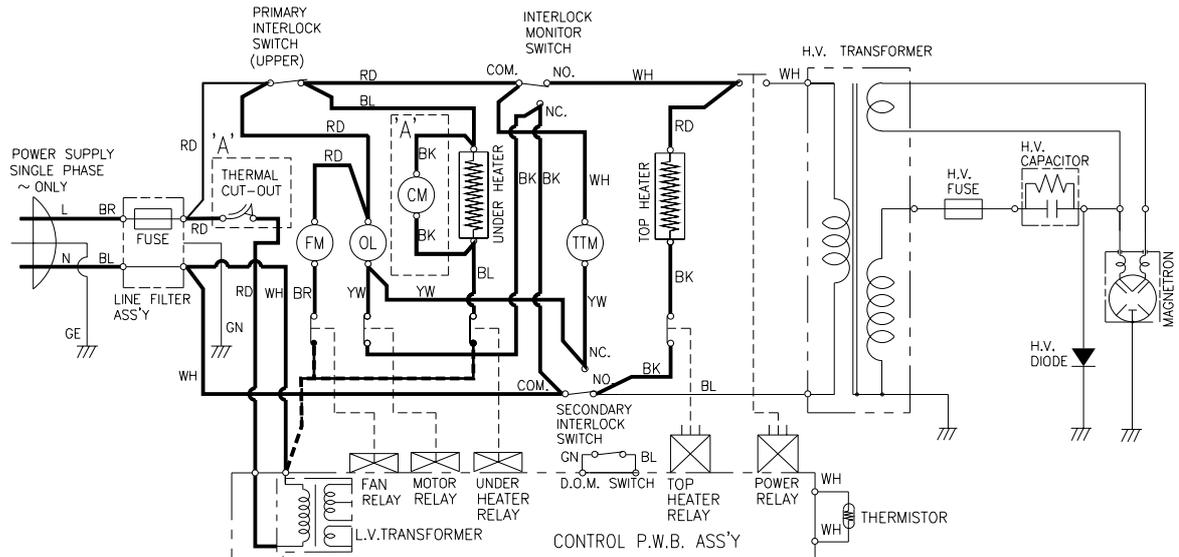

[CONDITION]

1. DOOR : CLOSED
2. COOK : OFF

OL : OVEN LAMP
 FM : FAN MOTOR
 CM : CONVECTION FAN MOTOR
 TTM : TURNTABLE MOTOR

RD : RED BL : BLUE GN : GREEN
 WH : WHITE YW : YELLOW GE : GREEN/YELLOW
 BK : BLACK BR : BROWN

*EXCEPT [A] :KOC-972T

*INCLUDING [A] :KOC-982T/983T/984T/985T

EXPLODED VIEWS AND PARTS LIST

1. KOC-972T

EXPLODED VIEW

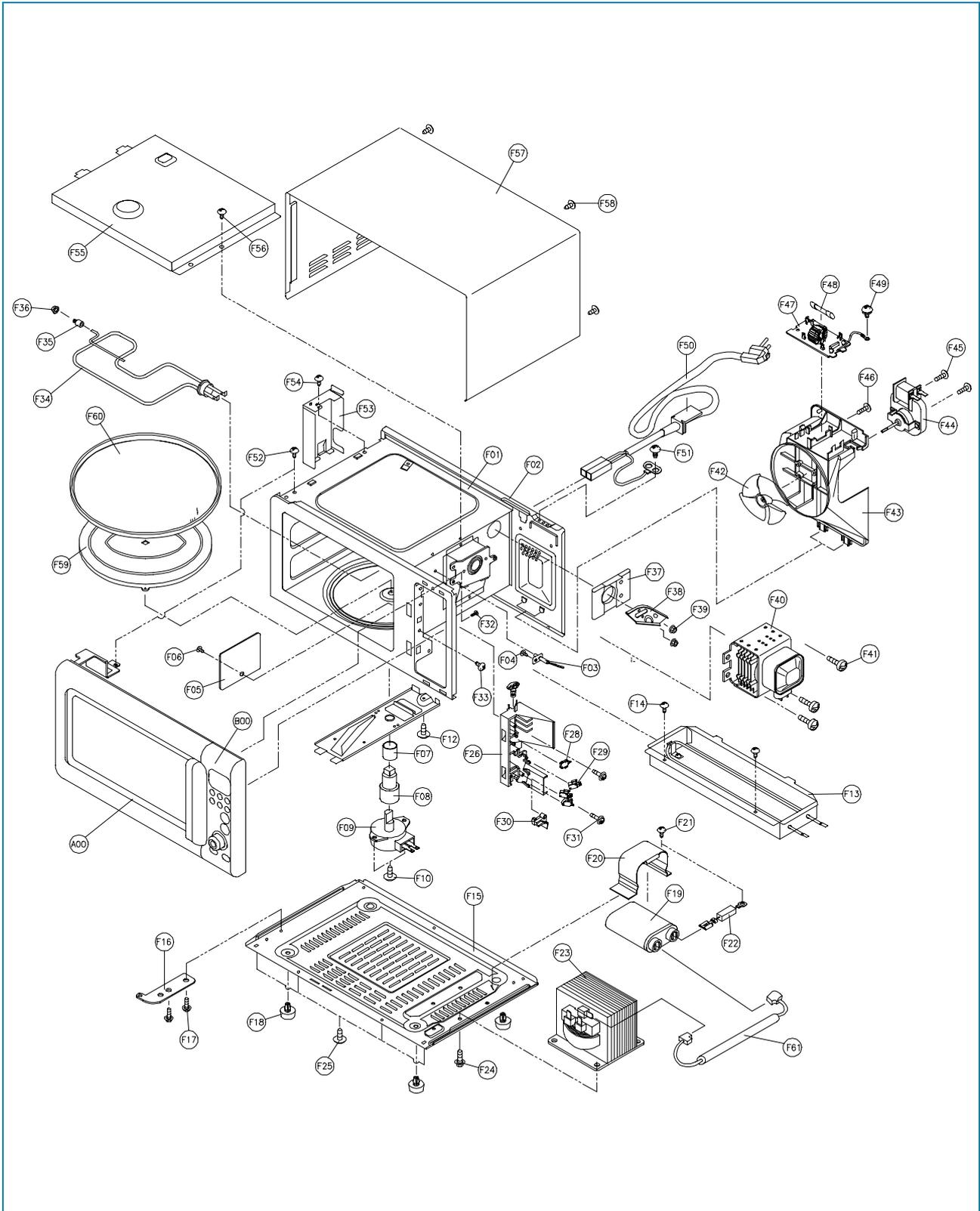

✓ **Caution:** In this Service Manual, some parts can be changed for improving, their performance without notice in the parts list. So, if you need the latest parts information, please refer to PPL(Parts Price List) in Service information Center(<http://svc.dwe.co.kr>)

EXPLODED VIEWS AND PARTS LIST

PARTS LIST

REF NO.	PART CODE	PART NAME	DESCRIPTION	QTY	REMARK
A00	3511708320	DOOR AS	KOC-972T	1	
B00	PKCPSWQ300	CONTROL-PANEL AS	KOC-972T0S	1	
	PKCPSWQ300	CONTROL-PANEL AS	KOC-972T2S	1	
F1	3516107900	CAVITY WELD AS	KOC-971C	1	
F2	3516503300	REAR-PLATE *O	SBHG-1 T0.6	1	
F3	3514800800	SENSOR TEMPERATURE	PTM-K312-D4	1	
F4	7113400814	SCREW TAPPING	T1 BIN 4*8 MFNI	1	
F5	3511403800	COVER WAVE GUIDE	MICA T0.5	1	
F6	7113400814	SCREW TAPPING	T1 BIN 4*8 MFNI	1	
F7	3514400600	PIPE	BRASS C3604BD	1	
F8	3517401300	COUPLER	CERAMIC	1	
F9	3966510200	MOTOR SYNCRO	230V 25W GM-16-24FD24	1	
F10	7121400811	SCREW TAPPING	T2S PAN 4*8 MFZN	2	
F11	3510604000	BRACKET MOTOR SYNCRO	SECC T0.8	1	
F12	7113400814	SCREW TAPPING	T1 BIN 4*8 MFNI	1	
F13	3512802100	HEATER *U AS	KOC-971COS	1	
F14	7113400814	SCREW TAPPING	T1 BIN 4*8 MFNI	2	
F15	3510310400	BASE	SBHG-1 T0.8	1	
F16	3515202810	STOPPER HINGE *U AS	KOC-970T	1	
F17	7S422X4081	SCREW SPECIAL	TT2 TRS 4*8 SE MFZN	2	
F18	3512100900	FOOT	PP, DASF-130	4	
F19	4416W67820	CAPACITOR HV	2100VAC, 1.1uF	1	
F20	441X304112	HOLDER HV CAPACITOR	SECC T0.8	1	
F21	7S422X4081	SCREW SPECIAL	TT2 TRS 4*8 SE MFZN	1	
F22	4416V24000	DIODE HV	SANKEN HVR-1X-32B(D5.3)	1	
F23	3518112100	TRANS HV	DY-90S0-97T1	1	
F24	7S427W40A1	SCREW SPECIAL	TT2 HEX FG 4*10 SE MFZN	4	
F25	7S312X40A1	SCREW SPECIAL	T1 TRS 4*10 SE MFZN	6	
F26	3513809100	LOCK	POM	1	
F27	3513601600	LAMP	BL 240V25W T25 C7A H187	1	
F28	5S762S10G0	SW MICRO	SZM-V16-FA-63	2	
F29	5S762310G0	SW MICRO	SZM-V16-FA-61	2	
F30	3513701300	LEVER LOCK	POM	1	
F31	7S341W40B1	SCREW SPECIAL	T2S PAN 4*12 PW SE MFZN	2	
F32	7S341W40B1	SCREW SPECIAL	T2S PAN 4*12 PW SE MFZN	1	
F33	7S422X4081	SCREW SPECIAL	TT2 TRS 4*8 SE MFZN	1	
F34	3512801900	HEATER *T	230V 1100W R28370001	1	

✓ **Caution:** In this Service Manual, some parts can be changed for improving, their performance without notice in the parts list. So, if you need the latest parts information, please refer to PPL(Parts Price List) in Service information Center(<http://svc.dwe.co.kr>)

EXPLODED VIEWS AND PARTS LIST

REF NO.	PART CODE	PART NAME	DESCRIPTION	QTY	REMARK
F35	3513002900	HOLDER HEATEER	BRASS C3604BD	1	
F36	7391800011	NUT HEX	6N-1-8 MFZN	1	
F37	3510603700	BRACKET HEATER *U	STS301 TO.6	1	
F38	3510603600	BRACKET HEATER *T	STS430 T1.0	1	
F39	7391400008	NUT	6N-1-4 SUS	2	
F40	3518002400	MAGNETRON	2M218J(MF)I	1	
F41	7S427W40A1	SCREW SPECIAL	TT2 HEX FG 4*10 SE MFZN	3	
F42	3511800100	FAN	PP GF20	1	
F43	3512505200	GUIDE WIND	PP	1	
F44	3963513000	MOTOR SHADED POLE	230V25W OEM-15DWC2-A03	1	
F45	7121403011	SCREW TAPPING	T2S PAN 4*30 MFZN	2	
F46	7S341W40B1	SCREW SPECIAL	T2S PAN 4*12 PW SE MFZN	1	
F47	3518604600	NOISE-FILTER	DWLF-P(KOC-972TOS)	1	
	3518605500	NOISE-FILTER	DWLF-MO7(KOC-972T2S)	1	
F48	4417B67600	FUSE	15A 250V	1	
	5F1CD1232M	FUSE	12A 250V	1	
F49	7S312X40A1	SCREW SPECIAL	T1 TRS 4*10 SE MFZN	1	
F50	35113A5Q5J	CORD POWER AS	3*1.5(KOC-972TOS)	1	
	35113A5QM5	CORD POWER AS	3*1.0(KOC-972T2S)	1	
F51	7S312X40A1	SCREW SPECIAL	T1 TRS 4*10 SE MFZN	2	
F52	7S427W40A1	SCREW SPECIAL	TT2 HEX FG 4*10 SE MFZN	2	
F53	3512505500	GUIDE AIR OUTLET	SA1D-80 TO.5	1	
F54	7S312X40A1	SCREW SPECIAL	T1 TRS 4*10 SE MFZN	1	
F55	3511401200	COVER INSULATOR *T	SECC TO.5	1	
F56	7S312X40A1	SCREW SPECIAL	T1 TRS 4*10 SE MFZN	1	
F57	3510801900	CABINET	PCM TO.5	1	
F58	7S312X40A1	SCREW SPECIAL	T1 TRS 4*10 SE MFZN	4	
F59	3512513000	GUIDE TRAY AS	KOC-971COS	1	
F60	3517205200	TRAY METAL	SPP TO.6	1	
F61	3518700220	FUSE HV	5KV 0.7A THVO60T	1	

2. KOC-982T/983T/984T/985T

EXPLODED VIEW

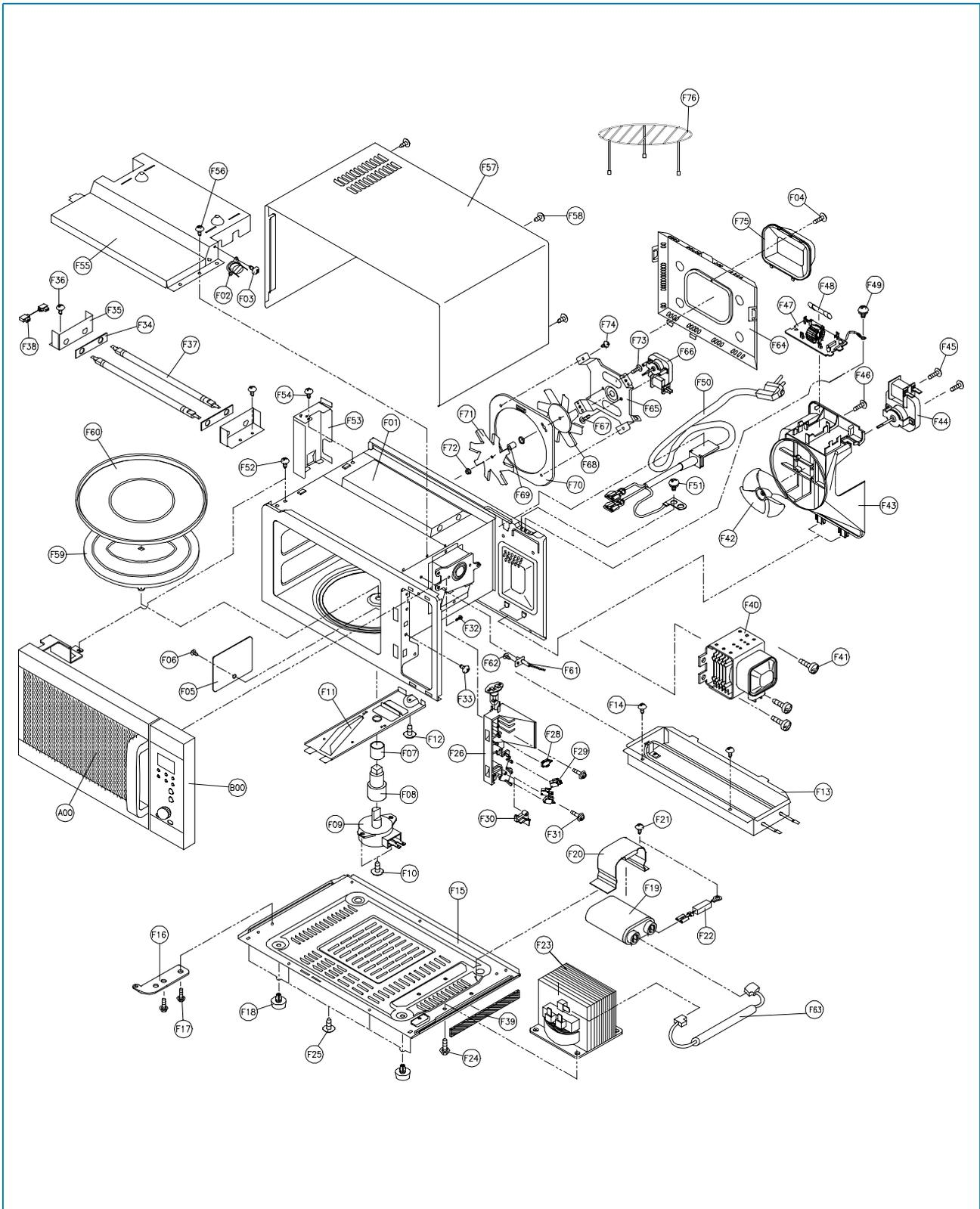

✓ **Caution:** In this Service Manual, some parts can be changed for improving, their performance without notice in the parts list. So, if you need the latest parts information, please refer to PPL(Parts Price List) in Service information Center(<http://svc.dwe.co.kr>)

EXPLODED VIEWS AND PARTS LIST

PARTS LIST

REF NO.	PART CODE	PART NAME	DESCRIPTION	QTY	REMARK
A00	3511708380	DOOR AS	KOC-984T	1	
	3511708390	DOOR AS	KOC-985T	1	
	3511710830	DOOR AS	KOC-983T	1	
	3511708320	DOOR AS	KOC-982T	1	
B00	PKCPSWYB00	CONTROL-PANEL AS	KOC-984T(SIMULTANEOUS)	1	
	PKCPSWYC00	CONTROL-PANEL AS	KOC-985T(SIMULTANEOUS)	1	
	PKCPSWYE00	CONTROL-PANEL AS	KOC-983T(SIMULTANEOUS)	1	
	PKCPSWQ350	CONTROL-PANEL AS	KOC-982T(SIMULTANEOUS)	1	
	PKCPSWYB00	CONTROL-PANEL AS	KOC-984T(SEQUENTIAL)	1	
	PKCPSWYC00	CONTROL-PANEL AS	KOC-985T(SEQUENTIAL)	1	
	PKCPSWYE00	CONTROL-PANEL AS	KOC-983T(SEQUENTIAL)	1	
	PKCPSWQ350	CONTROL-PANEL AS	KOC-982T(SEQUENTIAL)	1	
F01	3516107950	CAVITY WELD AS	KOC-980T1S	1	
F02	3518904400	THERMOSTAT	120/60, #187	1	
F03	7121400611	SCREW TAPPING	T2S PAN 4*6 MFZN	1	
F04	7112400811	SCREW TAPPING	T1 TRS 4X8 MFZN	1	
F05	3511403800	COVER WAVE GUIDE	MICA TO.5	1	
F06	7113400814	SCREW TAPPING	T1 BIN 4*8 MFNI	1	
F07	3514400600	PIPE	BRASS C3604BD	1	
F08	3517401300	COUPLER	CERAMIC	1	
F09	3966510200	MOTOR SYNCRO	230V 25W GM-16-24FD24)	1	
F10	7121400811	SCREW TAPPING	T2S PAN 4*8 MFZN	2	
F11	3510604000	BRACKET MOTOR SYNCRO	SECC TO.8	1	
F12	7113400814	SCREW TAPPING	T1 BIN 4*8 MFNI	1	
F13	3512802100	HEATER *U AS	KOC-971COS	1	
F14	7113400814	SCREW TAPPING	T1 BIN 4*8 MFNI	2	
F15	3510310400	BASE	SBHG TO.8	1	
F16	3515202800	STOPPER HINGE *U AS	KOR-121MOA	1	
F17	7S422X4081	SCREW SPECIAL	TT2 TRS 4*8 SE MFZN	2	
F18	3512101400	FOOT	PP, DASF-130	4	
F19	4416W67820	CAPACITOR HV	2100VAC, 1.1uF	1	
F20	441X304112	HOLDER HV CAPACITOR	SECC TO.8	1	
F21	7S422X4081	SCREW SPECIAL	TT2 TRS 4*8 SE MFZN	1	
F22	4416V24000	DIODE HV	SANKEN HVR-1X-32B(D5.3)	1	
F23	3518112100	TRANS HV	DY-N90S0-97T1	1	
F24	7S427W40A1	SCREW SPECIAL	TT2 HEX FG 4*10 SE MFZN	4	
F25	7S312X40A1	SCREW SPECIAL	T1 TRS 4*10 SE MFZN	5	
F26	3513809100	LOCK	POM	1	
F27	3513601600	LAMP	BL 240V 25W T25 C7A H187	1	
F28	5S762S10G0	SW MICRO	SZM-V16-FA-63	2	
F29	5S762310G0	SW MICRO	SZM-V16-FA-61	2	
F30	3513701300	LEVER LOCK	POM	1	
F31	7122401211	SCREW TAPPING	T2S TRS 4*12 MFZN	2	
F32	7122401211	SCREW TAPPING	T2S TRS 4*12 MFZN	1	

EXPLODED VIEWS AND PARTS LIST

Caution : In this Service Manual, some parts can be changed for improving, their performance without notice in the parts list. So, if you need the latest parts information, please refer to PPL(Parts Price List) in Service information Center(<http://svc.dwe.co.kr>)

REF NO.	PART CODE	PART NAME	DESCRIPTION	QTY	REMARK
F33	7S422X4081	SCREW SPECIAL	TT2 TRS 4*8 SE MFZN	1	
F34	3517502700	PROTECTOR HEATER	MICA MT56 T1.0	2	
F35	3510603610	BRACKET HEATER *T	SECC TO.6	2	
F36	7S312X40A1	SCREW SPECIAL	T1 TRS 4*10 SE MFZN	2	
F37	3512803000	HEATER MIRACLON	115V 550W	2	
F38	3512765100	HARNESS HEATER	#187 FLAG 65MM	1	
F39	3517302500	FOAM	CR 10T*180*30	1	
F40	3518002400	MAGNETRON	2M218J(MF)I	1	
F41	7S427W40A1	SCREW SPECIAL	TT2 HEX FG 4*10 SE MFZN	3	
F42	3511800100	FAN	PP GF20	1	
F43	3512505200	GUIDE WIND	PP	1	
F44	3963513000	MOTOR SHADED POLE	230V 25W OEM-15DWC2-AO3	1	
F45	7112403011	SCREW TAPPING	T2S PAN 4*30 MFZN	2	
F46	7122401211	SCREW TAPPING	T2S TRS 4*12 MFZN	1	
F47	3518604600	NOISE-FILTER	DWLF-P(SIMULTANEOUS)	1	
	3518605500	NOISE-FILTER	DWLF-MO7(SEQUENTIAL)	1	
F48	4417B67600	FUSE	15A 250V(SIMULTANEOUS)	1	
	5F1CD1232M	FUSE	12A 250V(SEQUENTIAL)	1	
F49	7112401011	SCREW TAPPING	T1 TRS 4*10 MFZN	1	
F50	35113A5Q5J	CORD POWER AS	3*1.5(SIMULTANEOUS)	1	
	35113A5QM5	CORD POWER AS	3*1.0(SIMULTANEOUS)	1	
F51	7112401011	SCREW TAPPING	T1 TRS 4*10 MFZN	2	
F52	7S427W40A1	SCREW SPECIAL	TT2 HEX FG 4*10 SE MFZN	2	
F53	3512505500	GUIDE AIR OUTLET	SA1D-80 TO.5	1	
F54	7112401011	SCREW TAPPING	T1 TRS 4*10 MFZN	1	
F55	3511404800	COVER INSULATOR *T	SECC TO.5	1	
F56	7112401011	SCREW TAPPING	T1 TRS 4*10 MFZN	1	
F57	3510801000	CABINET	PCM TO.5	1	
F58	7112401011	SCREW TAPPING	T1 TRS 4*10 MFZN	4	
F59	3512513000	GUIDE TRAY AS	KOC-971COS	1	
F60	3517205200	TRAY METAL	SPP TO.6	1	
F61	3514800800	SENSOR TEMPERATURE	PTM-K312-D4	1	
F62	7113400814	SCREW TAPPING	T1 BIN 4*8 MFNI	1	
F63	3518700220	FUSE HV	5KV 0.7A	1	
F64	3511401300	COVER INSULATOR *B	SBHG-1 0.6T	1	
F65	3510601500	BRACKET MOTOR	SBHG-1 0.8T	1	
F66	3963513200	MOTOR SHADED POLE	OEM-10DWC2-A09	1	
F67	7051400811	SCREW MACHINE	PAN 4*8 SW MFZN	2	
F68	441B629071	FAN	SBHG-1 0.6T	1	
F69	3514400400	PIPE	AL1100	1	
F70	3511401800	COVER INSULATOR	SA1D-80 0.7T	1	
F71	3511800400	FAN CONVECTION	SA1D-80 0.5T	1	
F72	7121400811	SCREW SPECIAL	NUT FLANGE M4 MFZN	1	
F73	7S627W50X1	SCREW TAPPING	T1 TRS 4*8 TB-W MFZN	1	
F74	7S627W50X1	SCREW TAPPING	T1 TRS 4*8 TB-W MFZN	4	
F75	3511402100	COVER *B	P.P	1	
F76	3517202611	TRAY RACK AS	KOC-961C0S 117MM	1	Metal Rack

PRINTED WIRING BOARD

1. CIRCUIT CHECK PROCEDURE

1. Low Voltage Transformer check

- The low voltage transformer is located on the P.C.B.
- Measuring condition (input voltage) : 230 VAC / 50 Hz

KOC-972T/982T			KOC-983T/984T/985T		
L.V.T. : DMR-101FS			L.V.T. : DMR-984FS		
	Terminal	Voltage		Terminal	Voltage
	1 - 2	230VAC/50Hz		1 - 3	230VAC/50Hz
	4 - 5	13.0 VAC		6 - 7	10.5 VAC
	6 - 7	35.0 VAC		7 - 8	10.5 VAC
	8 - 10	3.0 VAC	9 - 10	2.6 VAC	

Secondary side voltage of the low voltage transformer changes in proportion to fluctuation of power source voltage.
The allowable tolerance of the secondary voltage is within $\pm 5\%$ of normal voltage.

2. Voltage check

- Key check point (1-5: Micom Pin, 6: Display Pin)

NO	CHECK POINT	REMARK
1	PIN 63, 64	+5 VDC $\pm 5\%$
2	PIN 29, 32, 62	0 V
3	PIN 28	+5 VDC
4	PIN 45	
5	PIN 30, 31	
6	PIN 1, 25	2.6 VAC (Display filament voltage)

- Check method

NO	VOLTAGE	REMARK	
		KOC-982T	KOC-983T/984T/985T
1	+5 VDC	Replace Q3,ZD2,R25,C12	Replace Q3,ZD3,R26,C10
2	+12 VDC	Replace D2-D5,EC3,C11	Replace D7,D8,EC2,EC3,C14,C11
3	-24 VDC	Replace D6,EC4,R28,R29,ZD4	Replace D9,D10,EC4,EC5,C15

NOTE

The marks of the above corresponding voltages (+5, +12, -24VDC) are written on the PCB .
Each measuring points must be measured with GND points.

3. Display Problems

NO	CAUSE	MEASUREMENT	RESULT	REMEDY
1	Poor contact between P.C.B. and display filament	Check the voltage of display pin 1 & 25	2.6 VAC	Fix the pin 1 & 25 on the P.C.B.
2	The display has some trouble in its segment or grid	Refer to The display trouble shooting data below		Replace P.C.B. assembly
3	Loss vacuum in the display	Find white spot		Replace P.C.B. assembly

- The display trouble shooting data

TROUBLE	DISPLAY NAME & PIN NO.	MICOM OUTPUT IN PIN NO.
Grid 1 doesn't come on.	Grid 1 (G1), 4, 7	13
Grid 2 doesn't come on.	Grid 2 (G2), 10	16
Grid 3 doesn't come on.	Grid 3 (G3), 14	18
Grid 4 doesn't come on.	Grid 4 (G4), 17	17
Grid 5 doesn't come on.	Grid 5 (G5), 21	24
Segment a doesn't come on from G1 to G5	Segment a, 23	26
Segment b doesn't come on from G1 to G5	Segment b, 22	25
Segment c doesn't come on from G1 to G5	Segment c, 20	23
Segment d doesn't come on from G1 to G5	Segment d, 19	22
Segment e doesn't come on from G1 to G5	Segment e, 18	21
Segment f doesn't come on from G1 to G5	Segment f, 16	20
Segment g doesn't come on from G1 to G5	Segment g, 15	19
Segment h doesn't come on from G1 to G5	Lower bar h, 5	14
Segment i doesn't come on from G1 to G5	Upper bar i, 6,8,9,11	15

4. Case of no microwave oscillation

(1) Situation : When touching M/W button, oven lamp turns on, fan motor and turntable motor rotate and cook indicator in the display comes on.

- CAUSE : Relay 1 (RY1) does not operate.

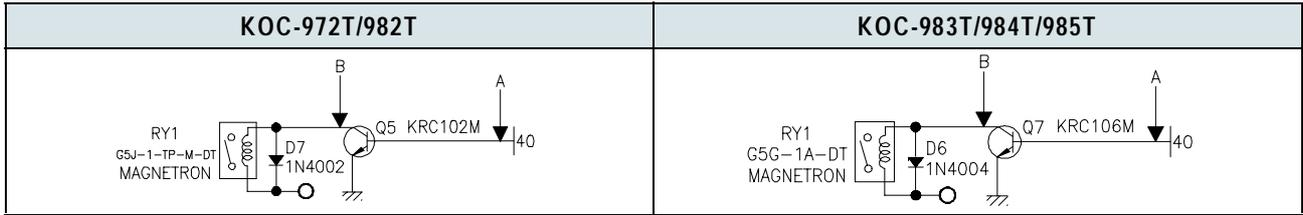

- Check method

STAGE	POINT A	POINT B
RELAY ON	+5 VDC	GND
RELAY OFF	GND	+12 VDC

(2) Situation : When touching M/W button, oven lamp does not turn on and turntable motor does not rotate but cook indicator in the display comes on.

- CAUSE : Relay 4 (RY4) does not operate.(KOC-972T/982T)
Relay 3 (RY3) does not operate.(KOC-983T/984T/985T)

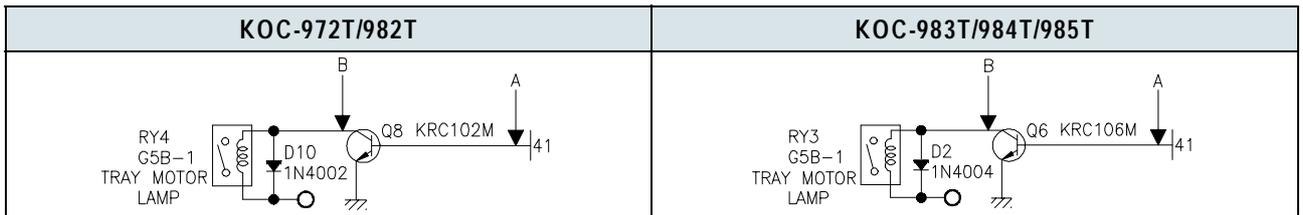

- Check method

STAGE	POINT A	POINT B
RELAY ON	+5 VDC	GND
RELAY OFF	GND	+12 VDC

(3) Situation : When touching M/W button, oven lamp turns on and fan motor does not rotate but cook indicator in the display comes on.

- CAUSE : Relay 5 (RY5) does not operate.(KOC-972T/982T)
Relay 4 (RY4) does not operate.(KOC-983T/984T/985T)

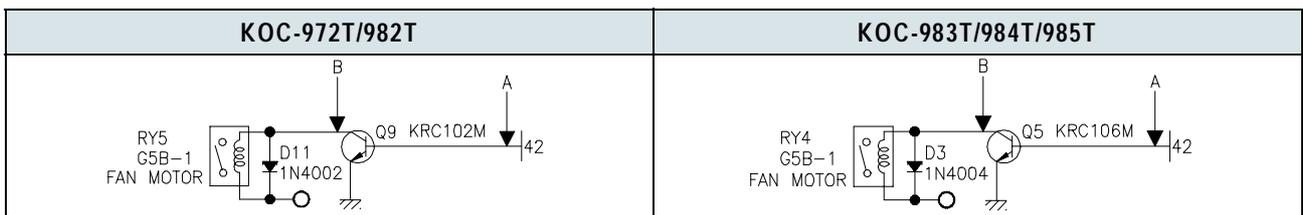

- Check method

STAGE	POINT A	POINT B
RELAY ON	+5 VDC	GND
RELAY OFF	GND	+12 VDC

5. Case of no heating of upper heater

When touching TEMP COOK & COMBI button, oven lamp turns on, fan motor and turntable motor rotate and cook indicator in the display comes on.

- CAUSE : Relay 2 (RY2) does not operate.

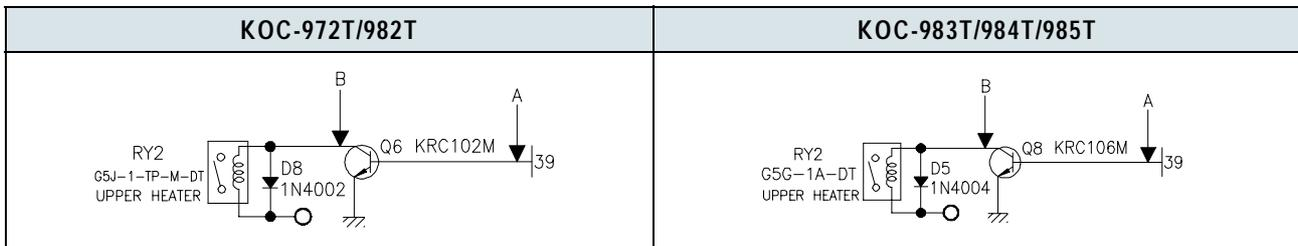

- Check method

STAGE	POINT A	POINT B
RELAY ON	+5 VDC	GND
RELAY OFF	GND	+12 VDC

6. Case of no heating of lower heater

When touching TEMP COOK & PIE button, oven lamp turns on, fan motor and turntable motor rotate and cook indicator in the display comes on.

- CAUSE : Relay 6 (RY6) does not operate.(KOC-972T/982T)
 Relay 5 (RY5) does not operate.(KOC-983T/984T/985T)

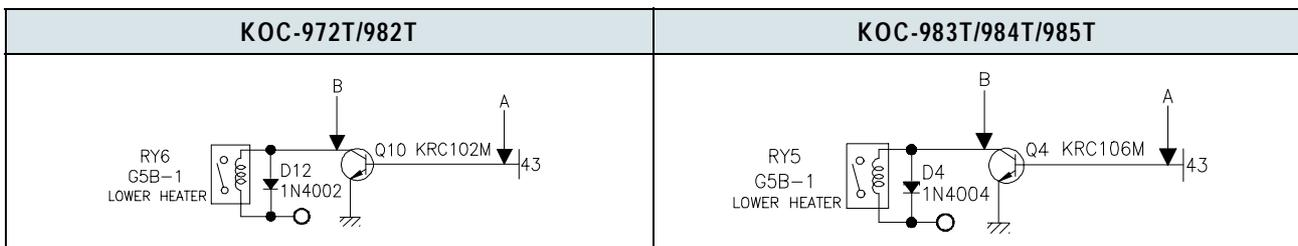

- Check method

STAGE	POINT A	POINT B
RELAY ON	+5 VDC	GND
RELAY OFF	GND	+12 VDC

7. Case of no stopping of the count down timer

When the door is opened during operation, the count down timer does not stop.

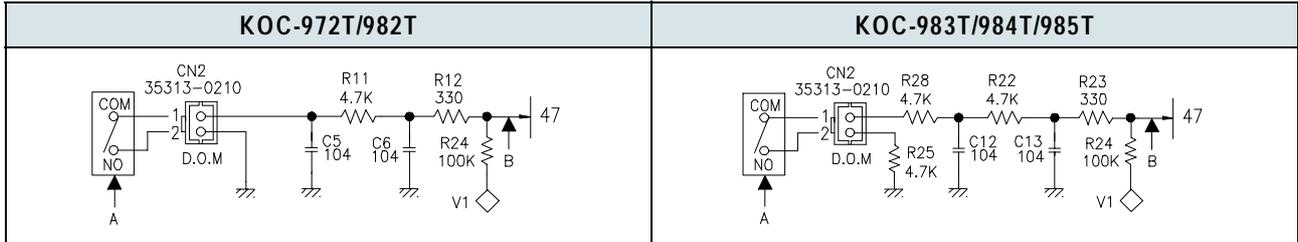

- Check method

STAGE	POINT A	POINT B
Door opened	Open	+5 VDC
Door closed	Closed	GND

NOTE

Check the state (ON, OFF) of the secondary interlock switch by resistance measurement.

8. Case of appearing Err6 on the display

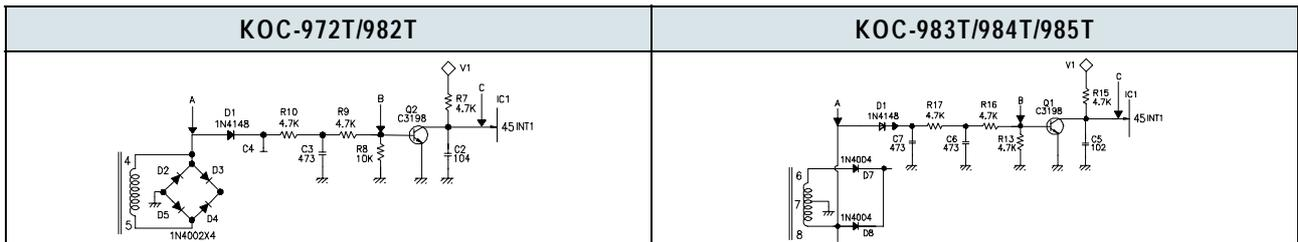

- Check method

POINT	WAVEFORM
A	
B	
C	<p style="text-align: right;">T: 20 ms (50Hz)</p>

NOTE

If clock does not keep exact time, you must check Diode D1 & Transistor Q2 (KOC-972T/982T), Diode D1 & Transistor Q1(KOC-984T/985T).

P.C.B. CIRCUIT DIAGRAM

1. KOC-972T/982T

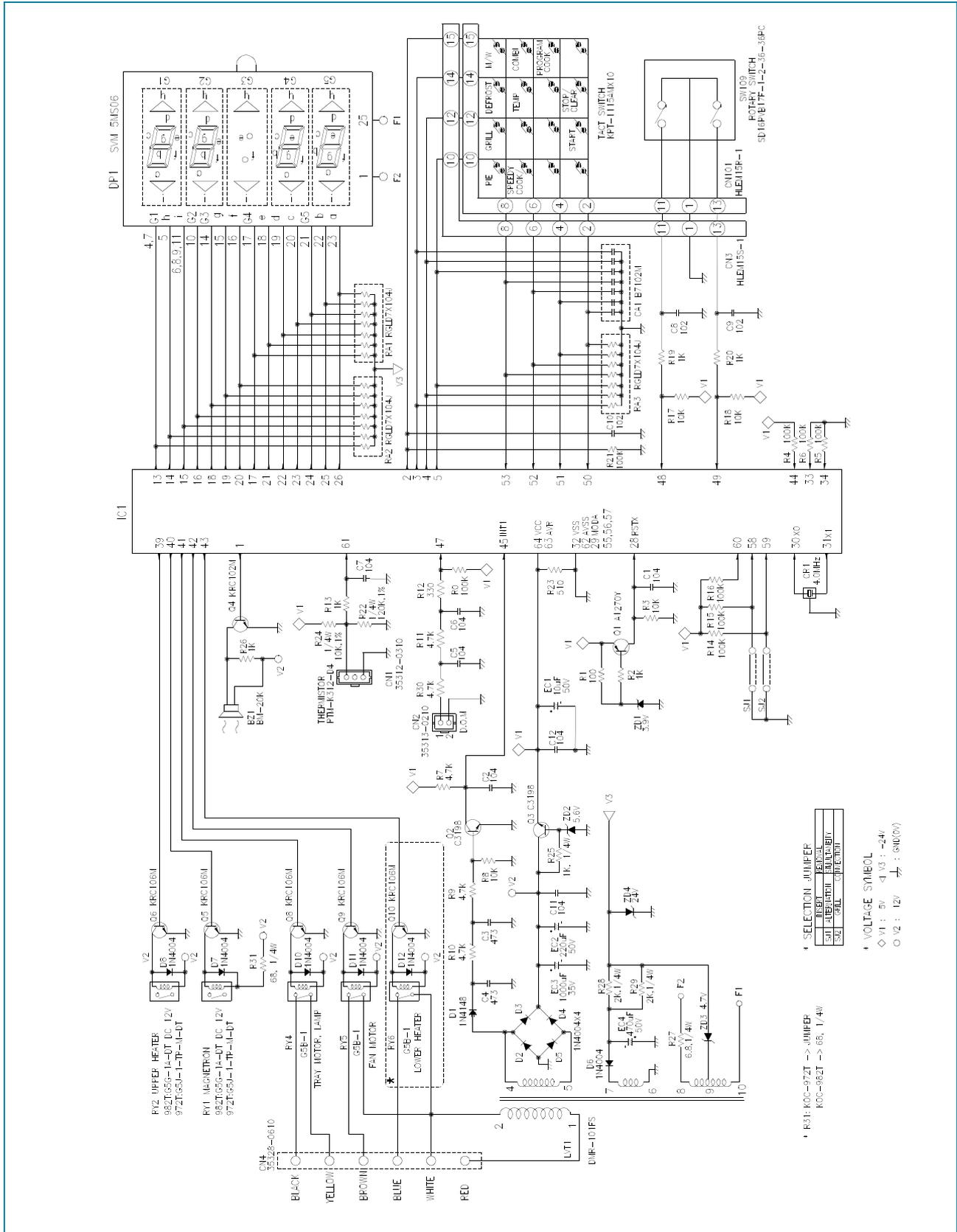

✓ **Caution:** In this Service Manual, some parts can be changed for improving, their performance without notice in the parts list. So, if you need the latest parts information, please refer to PPL(Parts Price List) in Service information Center(<http://svc.dwe.co.kr>)

P.C.B. CIRCUIT DIAGRAM

KOC-972T/982T PCB ASS'Y PART LIST

NAME	SYMBOL	SPECIFICATION	PART CODE	QTY
PCB	M212	93X197	3514314940	1
	M213	84X192	3514314950	1
TRANS POWER	LVT1	DMR-101FS	5EPV041351	1
HOLDER VFD	HD1	PP KOR-9930	3513002000	1
BUZZER	BZ1	BM-20K	3515600100	1
DIGITRON	DP1	SVM-5SS13	DSVM5SS13-	1
RESONATOR CERA	CR1	CST4.00MGW	5PCST400MG	1
IC MICOM	IC1	MB89143AP-171,972T	141SC871C0	1
		MB89144AP-249,982T	141SC981C0	1
R CARBON FILM	R25	1/4W, 1K OHM J	RD-4Z102J-	1
R CARBON FILM	R28,29	1/4W, 2K OHM J	RD-4Z202J-	2
R CARBON FILM	R27	1/4W, 6.8 OHM J	RD-4Z689J-	1
R CARBON FILM	RO,4-6,14~16,21	1/6W, 100K OHM J	RD-AZ104J-	8
R CARBON FILM	R7,9~11	1/6W, 4.7K OHM J	RD-AZ472J-	4
R CARBON FILM	R3,8,17,18	1/6W, 10K OHM J	RD-AJ103J-	4
R CARBON FILM	R2,13,19,20,26	1/6W, 1K OHM J	RD-AZ102J-	5
R CARBON FILM	R23	1/6W, 510 OHM J	RN-AZ510J-	1
R CARBON FILM	R12	1/6W, 330 OHM J	RD-AZ331J-	1
R CARBON FILM	R1	1/6W, 100 OHM J	RD-AZ101J-	1
R CARBON FILM	R22	1/4W, 120K OHM F	RN-4Z1203F	1
R CARBON FILM	R24	1/4W, 10K OHM F	RN-4Z1002F	1
R CARBON FILM	R31	1/4W, 68 OHM J 982T	RD-4Z680J-	1
DIODE SWITCHING	D1	1N4148M	DZN4148M-	1
DIODE ZENER	D2~8,10,11	1N4002A	DZN4002A--	9
DIODE ZENER	ZD1	MTZ 3.9B	DZUZ3R9BSB	1
DIODE ZENER	ZD2	UZ 5.6B	DZUZ5R6BSB	1
DIODE ZENER	ZD3	MTZ 4.7B	DZUZ4R7BSB	1
DIODE ZENER	ZD4	MTZ 24B	DZUZ24BSB-	1
C ELECTRO	EC1	RS 50V 10 μ F	CEXE1H100A	1
C ELECTRO	EC3	RSS 25V 2200 μ F	CEXF1V102V	1
C ELECTRO	EC4	RSS 50V 470 μ F	CEXF1H471V	1
C ARRAY	CA1	8P(7)50V 1000pF	CN7XB-102M	1
C CERA AXIAL	C1,2,5~7,11,12	H1KF 50V 0.1 μ FZ	CCKF1H104Z	7
C CERA AXIAL	C8~10	H1KF 50V 1000pF	CCZB1H102K	3
C CERA AXIAL	C3,4	H1KF 50V 0.47 μ F	CCKF1H473Z	2
CONNECTOR WAFER	CN1	35312-0310	30166M5030	1
CONNECTOR WAFER	CN2	35313-0210	30166M7020	1
CONNECTOR WAFER	CN4	35328-0610	4CW3061MX0	1
CONNECTOR FILM	CN3	HLEM15S-1	4CW215SBD0	1
TRANSISTOR	Q1	KTA1270Y	TZTA1270Y-	1
TRANSISTOR	Q2,3	KTC3198GR	TZTC3198GR	2
TRANSISTOR	Q4~6,8,9	KRC102M	TZRC102M-	5
RELAY	RY1,RY2	G5J-1-TP-M-DT-12 972T	5SC0101112	2
		G5G-1A-DT DC12V 982T	5SC0101123	2
RELAY	RY4,RY5,RY6	G5B-1-12V	5SC0101110	2
R ARRAY	RA1~RA3	8P (7) 1/8 100KJ	RA-88X104J	3
CONNECTOR FILM	CN101	HLEM15R-1	4CW21RBD0	1
SW TACT	SW101~108,110,111	KPT-1115AM	5S50101Z93	10
SW ROTARY	SW109	SDB161VB17F-1-2-36-36PC(PITCH5)	5S10109002	1

KOC-983T/984T/985T

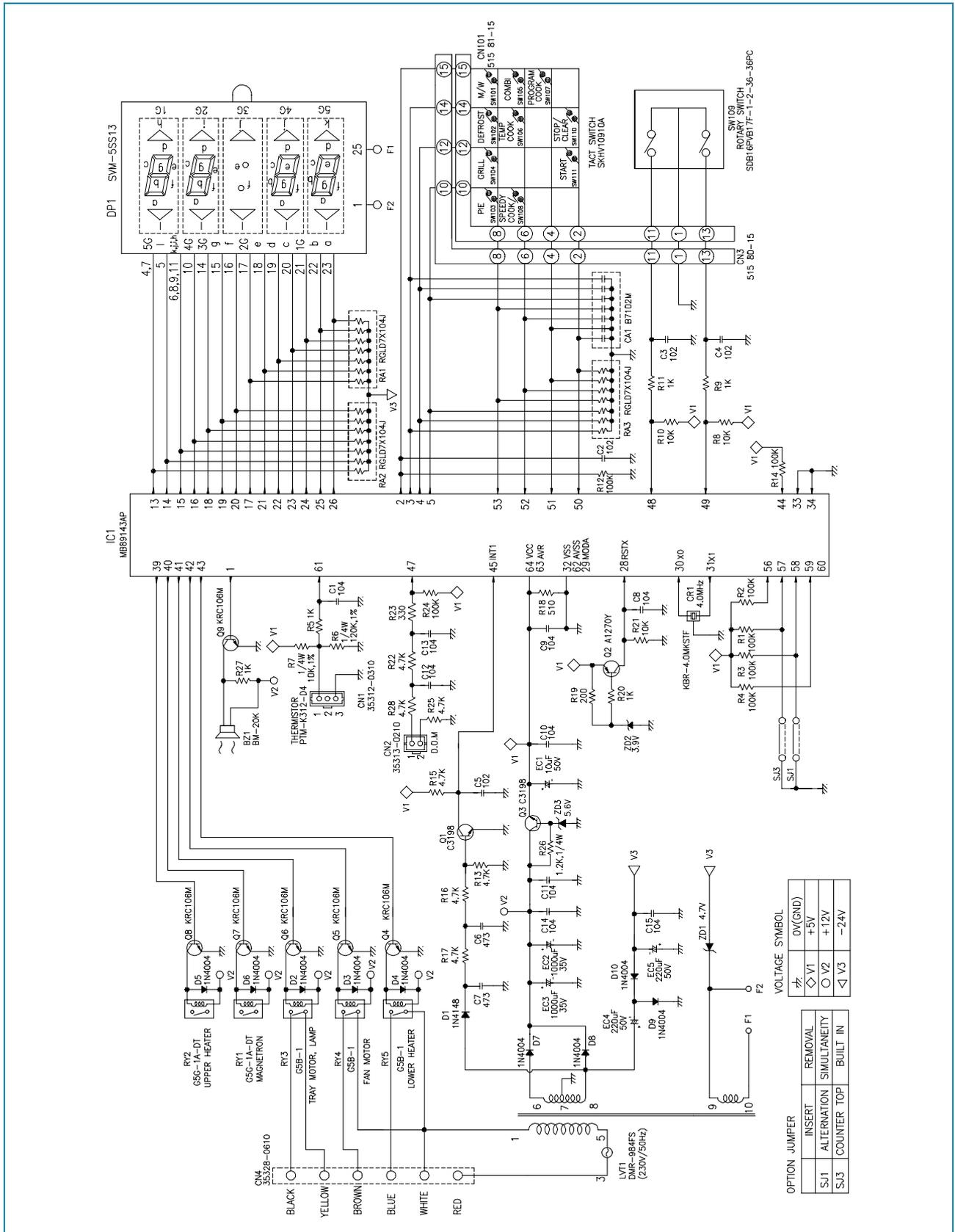

✓ **Caution:** In this Service Manual, some parts can be changed for improving, their performance without notice in the parts list. So, if you need the latest parts information, please refer to PPL(Parts Price List) in Service information Center(<http://svc.dwe.co.kr>)

P.C.B. CIRCUIT DIAGRAM

KOC-983T/984T/985T PCB ASS'Y PART LIST

NAME	SYMBOL	SPECIFICATION	PART CODE	Q'TY
PCB	M218	93X213	3514314980	1
	M219	91.5X163	3514314990	1
BUZZER	BZ1	BM-20K	3515600100	1
CONNECTOR WAFER	CN1	35312-0310	30166M5030	1
CONNECTOR WAFER	CN2	35313-0210	30166M7020	1
CONNECTOR WAFER	CN3	515 80-15	4CW215SBD0	1
CONNECTOR WAFER	CN4	35328-0610	4CW3061MX0	1
CONNECTOR WAFER	CN101	515 81-15	4CW215RBD0	1
DIGITRON	DP1	SVM-5SS13	DSVM5SS13-	1
HOLDER VFD	DPH	PP KOR-9930	3513002000	1
IC MICOM	IC1	MB89143AP-241	141SC984T0	1
TRANS POWER	LVT1	DMR-984FS	5EPV041305	1
SW RELAY	RY1,RY2	G5G-1A-DT DC 12V	5SC0101123	2
SW RELAY	RY3.RY4,RY5	G5B-1 DC 12V	5SC0101110	3
RESONATOR CERA	CR1	KBR-4.0MKSTF	5PKBR40MKS	1
C ELECTRO	EC1	RS 50V 10uF	CEXE1H100A	1
C ELECTRO	EC2,EC3	RSS 35V 1000 uF	CEXF1V102V	2
C ELECTRO	EC4,EC5	RSS 50V 220 uF	CEXF1H221V	2
TRANSISTOR	Q1,Q3	KTC3198GR	TZTC3198GR-	2
TRANSISTOR	Q2	KTA1270Y	TZTA1270Y-	1
TRANSISTOR	Q4---Q9	KRC106M	TZRC106M--	6
C CERA AXIAL	C1,C8-C15	H1KF 50V 0.1uF Z	CCZF1H104Z	9
C CERA AXIAL	C6,C7	H1KF 50V 0.047uF Z	CCZF1H473Z	2
C CERA AXIAL	C2-C5	H1KF 50V 1000pF K	CCZF1H102Z	4
C ARRAY	CA1	8P(7) 50V 1000 pF	CN7XB-102M	1
DIODE SWITCHING	D1	1N4148M	DZN4148M--	1
DIODE SWITCHING	D2-D10	1N4004A	DZN4004A--	9
R CARBON FILM	R1-R4,R12,R14,R24	1/6W, 100K OHM J	RD-AZ104J-	7
R CARBON FILM	R5,R9,R11,R20,R27	1/6W, 1K OHM J	RD-AZ102J-	5
R CARBON FILM	R6	1/4W, 120K OHM F	RN-4Z1203F	1
R CARBON FILM	R7	1/4W, 10K OHM F	RN-4Z1002F	1
R CARBON FILM	R8,R10,R21	1/6W, 10K OHM J	RD-AZ103J-	3
R CARBON FILM	R13,R15-R17,R22,R28	1/6W, 4.7K OHM J	RD-AZ472J-	6
R CARBON FILM	R18	1/6W, 510 OHM J	RD-AZ511J-	1
R CARBON FILM	R19	1/6W, 200 OHM J	RD-AZ201J-	1
R CARBON FILM	R23	1/6W, 330 OHM J	RD-AZ331J-	1
R CARBON FILM	R26	1/4W, 1,2K OHM J	RD-4Z122J-	1
R ARRAY	RA1,RA2,RA3	8P(7) 1/8 100K J	RA-88X104J	3
DIODE ZENER	ZD1	MTZ J 4.7B	DZUZ4R7BSB	1
DIODE ZENER	ZD2	MTZ J 3.9B	DZUZ3R9BSB	1
DIODE ZENER	ZD3	MTZ J 5.6B	DZUZ5R6BSB	1
SW ROTARY	SW109	SDB161PVB17F-1-2 -36-36PC(PITCH 5)	5S10109002	1
WIRE FLAT	WF1	1.25X15X90XC	WSJ-159007	1
SW TACT	SW101-SW108 SW110,SW111	SKHV10910A	5S50101Z90	10