SERVICE MANUAL

RGE24...



PRECAUTIONS TO BE OBSERVED BEFORE AND DURING SERVICING TO AVOID POSSIBLE EXPOSURE TO EXCESSIVE MICROWAVE ENERGY

SAFETY AND PRECAUTIONS

- 1) For starters, be sure to check any chances of the leakage of electricity."
- 2) You could handle a part in the vicinity of electricity after unplugging.
- 3) You should put on rubber gloves to prevent an electric shock on operation test.
- 4) Make sure the rated current,voltage,capacity before using an instrument."
- 5) Keep your wet hands away from the metal goods in the freezer compartment not to be frostbitten.
- 6) Be careful not to let water permeate the electric part in the machine room.
- 7) With door open during your working,you might be damaged by door."
- 8) You should give a title to the refrigerator for your safe after removing the breakable goods inside the refrigerator.
- 9) You'd better use cotton gloves if you fix it up around the evaporator

TABLE OF CONTENTS

1. SPECIFICATION	2
2. EXTERNAL VIEW-----	3
3. NAME OF EACH PART	4
4. COLD AIR CIRCULATION	5
5. REFRIGERANT CYCLE DIAGRAM	6
6. MACHINE ROOM VIEW AND PART LIST	7
7. PCB CIRCUIT DIAGRAM	8
8. SPECIFICATION OF ELECTIRC PARTS	11
9. HOW TO REPLACE THE PARTS	12
10. PCB CONTROL FUNCTION	17
11. EXPLODE VIEW AND PARTS LIST	38

1. SPECIFICATION

MODEL NAME		RGE24...	
		ISO	KS
STORAGE VOLUME	Total	240	243
	Freezer	64	67
	Refrigerator	176	176
EXTERNAL DIMENSION	WIDTH(mm)	553	
	DEPTH(mm)	629	
	HEIGHT(mm)	1605	
REFRIGERANT	R-600a	36g	
COOLING & CONTROL SYSTEM	COOLING SYSTEM	FAN COOLING SYSTEM	
	DEFROST SYSTEM	FIN EVAPORATOR FORCED	
	DEFROST CONTROL	AUTOMATIC START & STOP	
NET WEIGHT(KG)		50	

2. EXTENAL VIEW

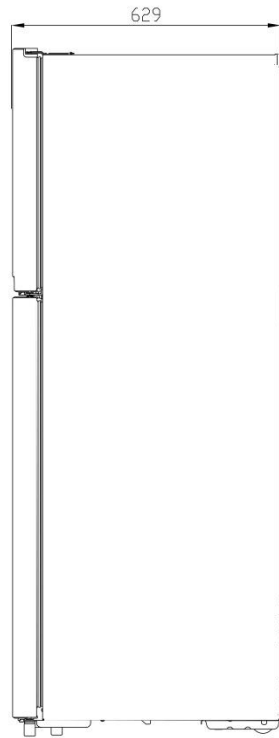
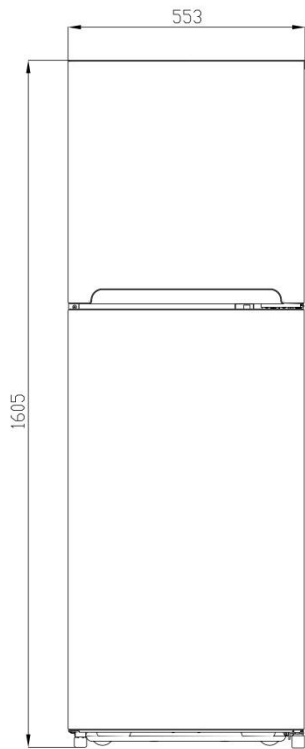
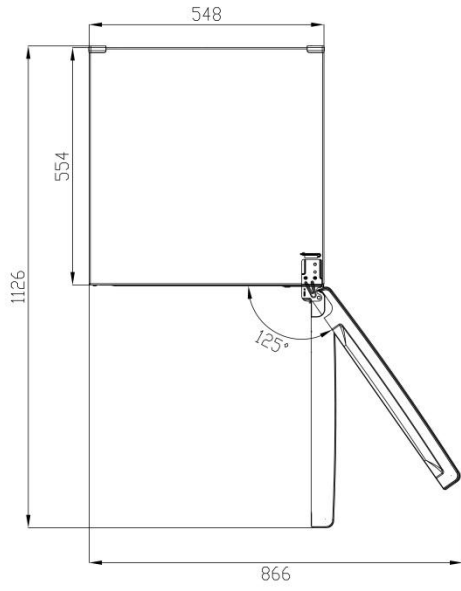

3. Name Of Each Part

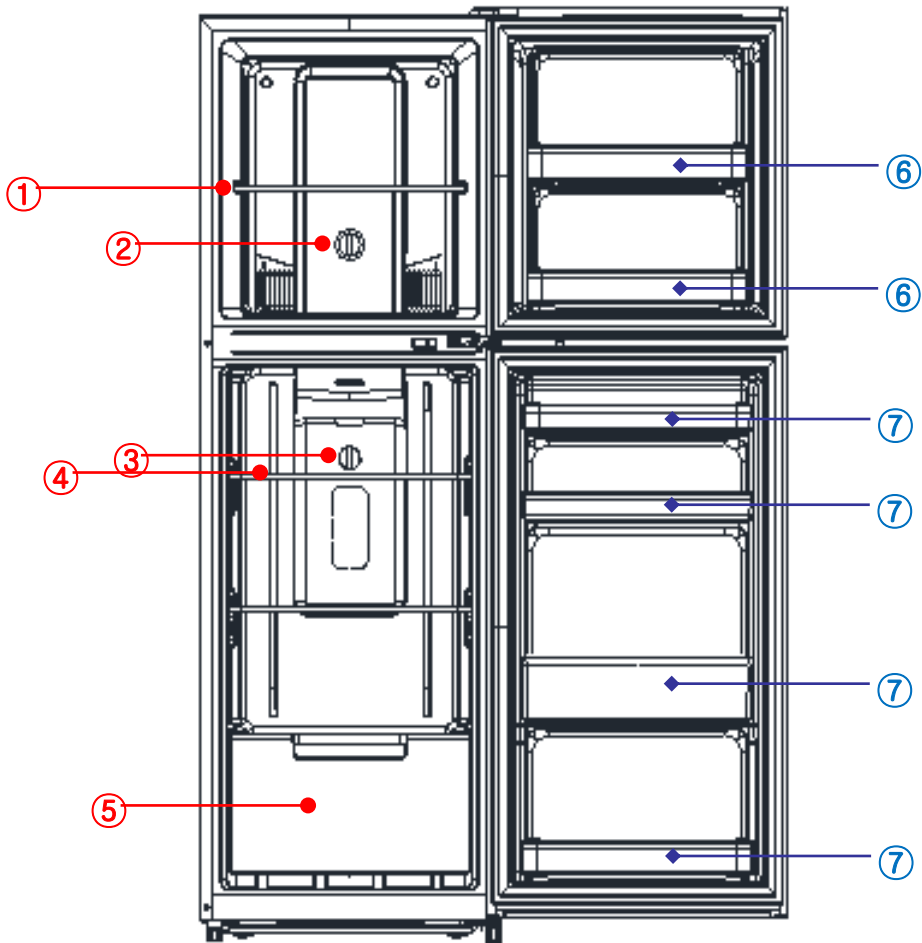

1. Freezer Compartment Shelf	7. Fresh Food Compartment Shelves
2. Freezer Compartment Temperature Controller	
3. Fresh Food Compartment Temperature Controller	
4. Fresh Food Compartment Shelves	
5. Vegetable Case	
6. Freezer Compartment Pockets	

4. Cold Air Circulation

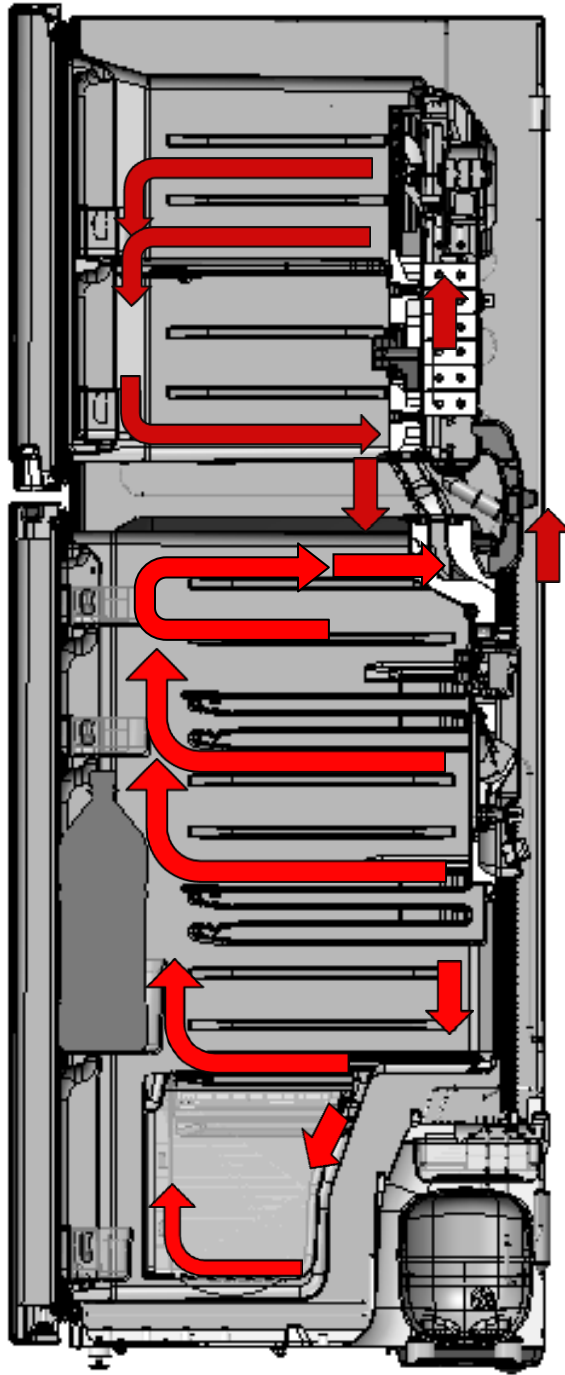

5. REFRIGERANT CYCLE DAIGRAM

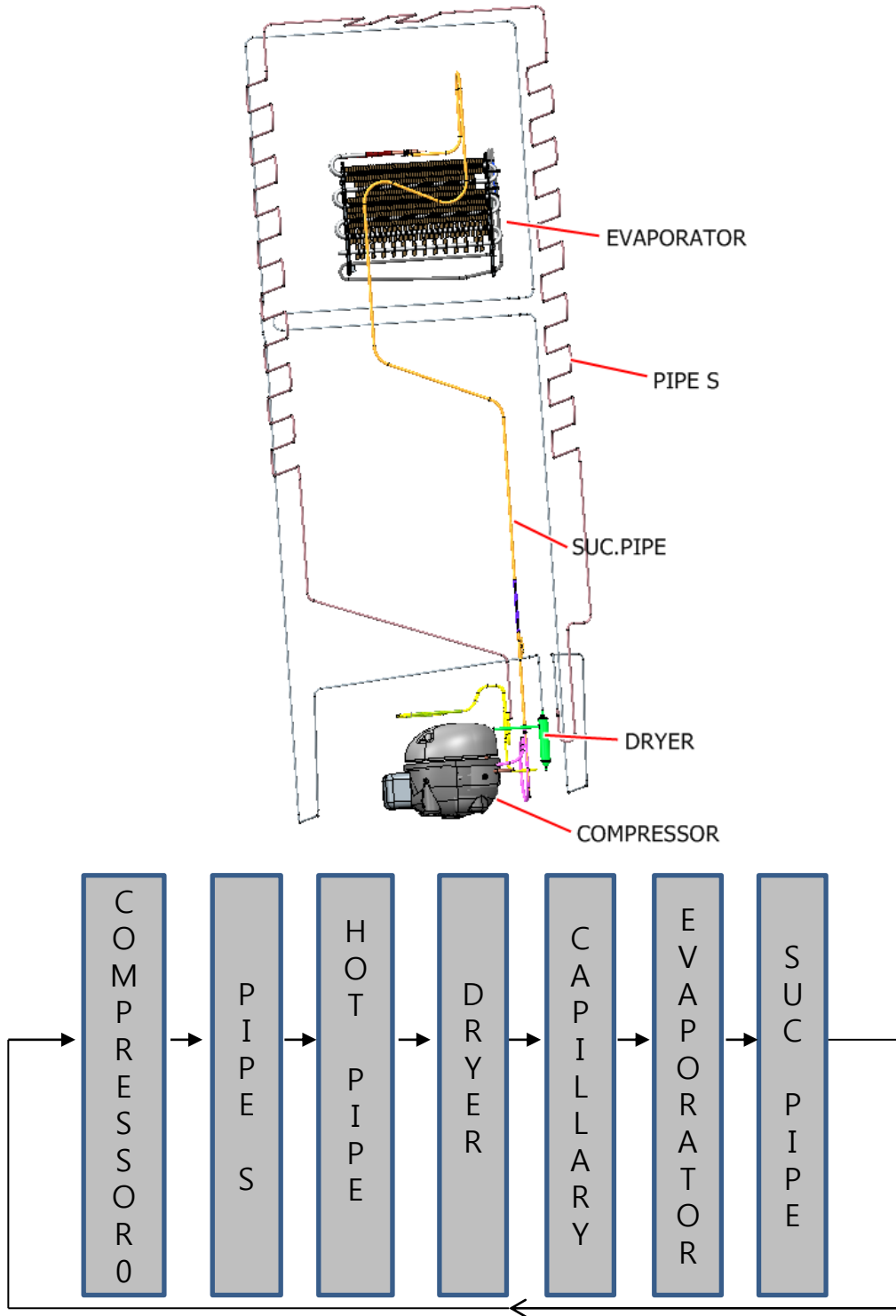

6. MACHINE ROOM VIEW AND PART LIST

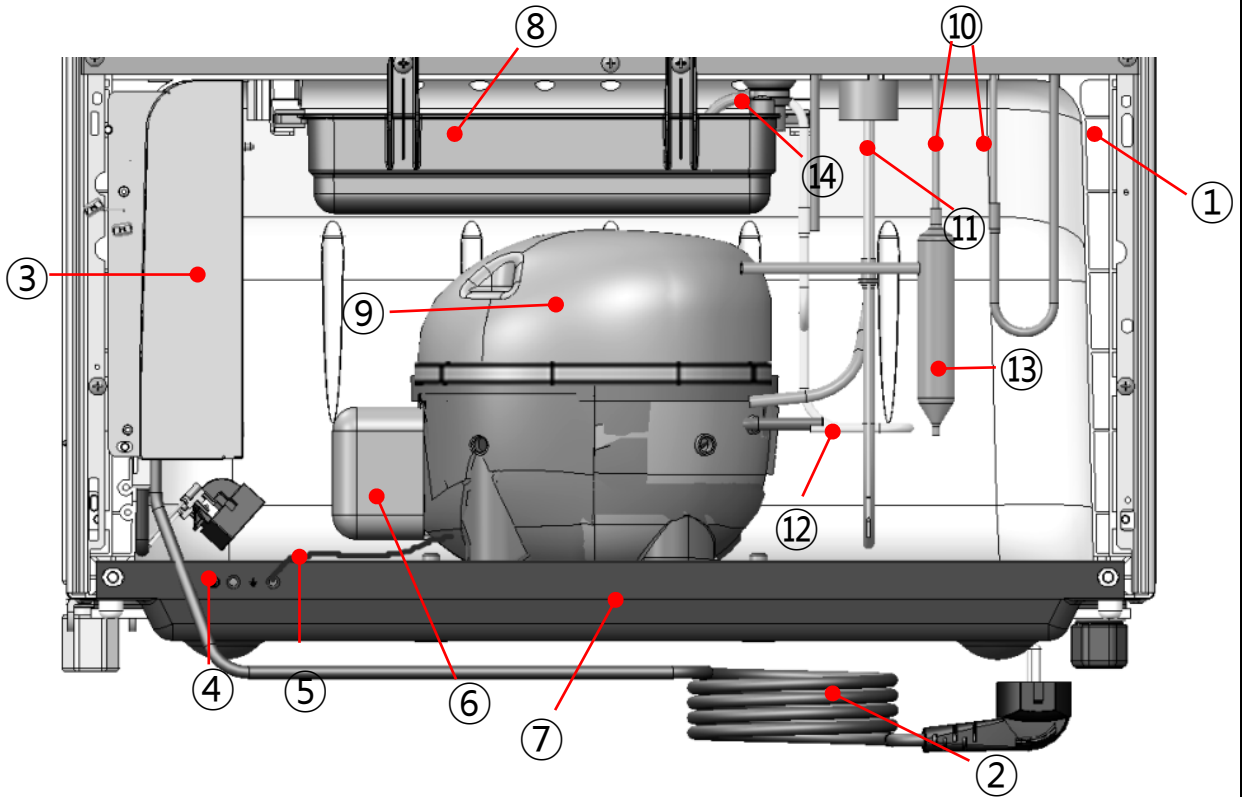

NO	PART NAME	NO	PART NAME
1	CABINET	9	COMPRESSOR
2	CORD POWER AS	10	PIPE HOT
3	BOX M/PCB AS	11	PIPE SUC AS
4	SCREW EARTH	12	PIPE SUC CONN AS
5	HARNESS EARTH	13	DRYER AS
6	COVER RELAY	14	PIPE DELI CONN AS
7	BASE COMP AS		
8	CASE VAPORI		

7. PCB CIRCUIT DIAGRAMS

7-1. Dial Type

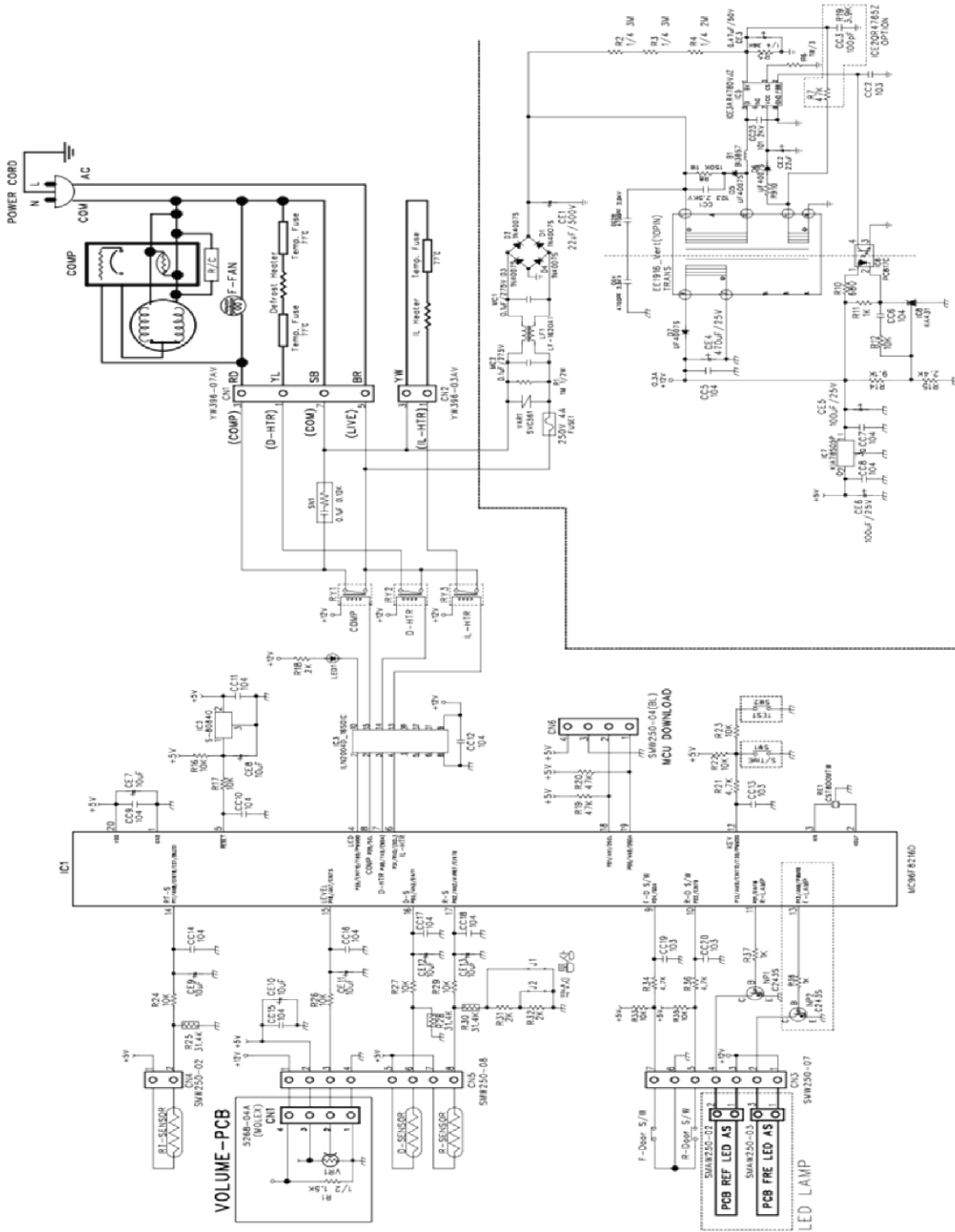

7-2. FCP Type

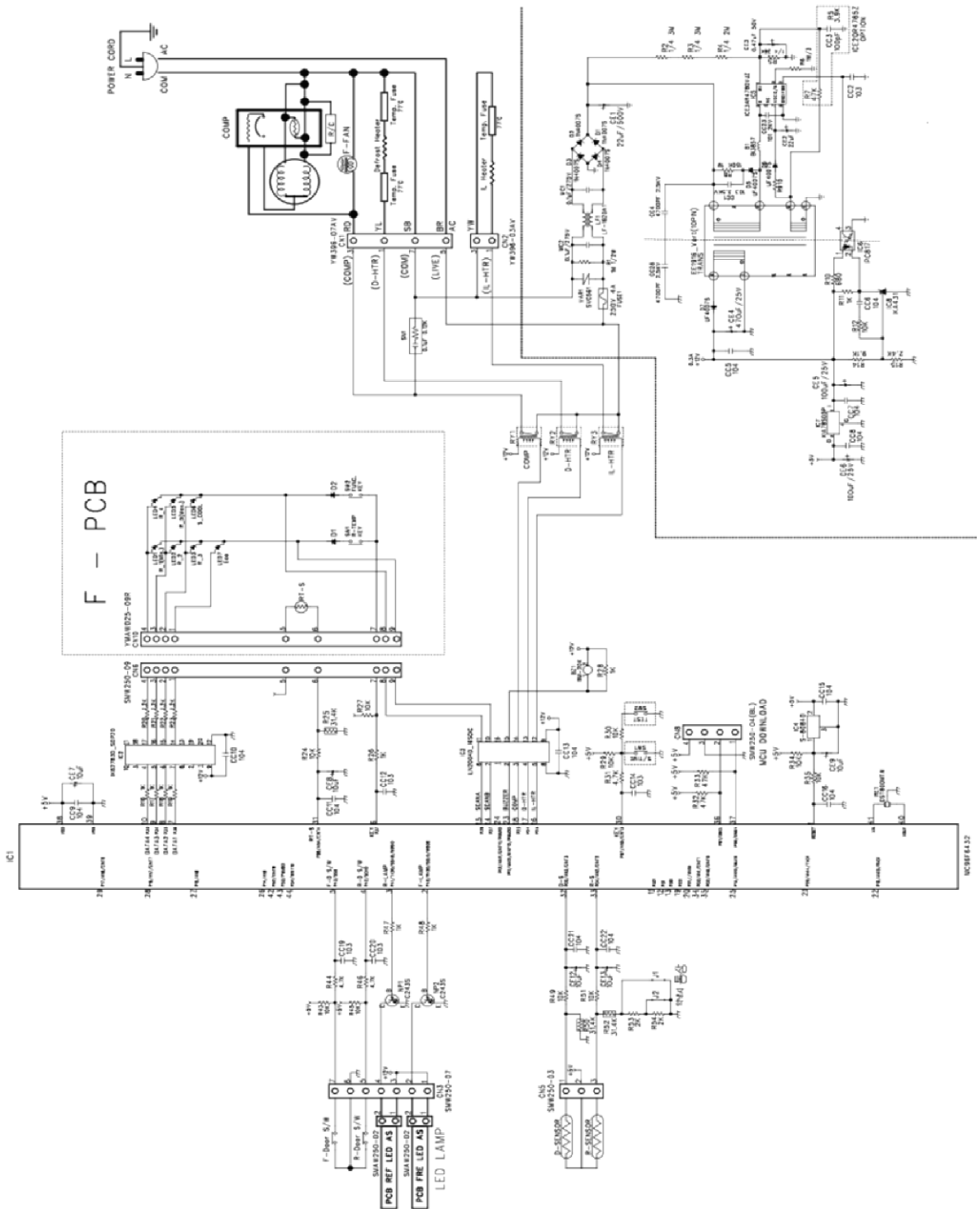

7-3. Dial Inverter Type

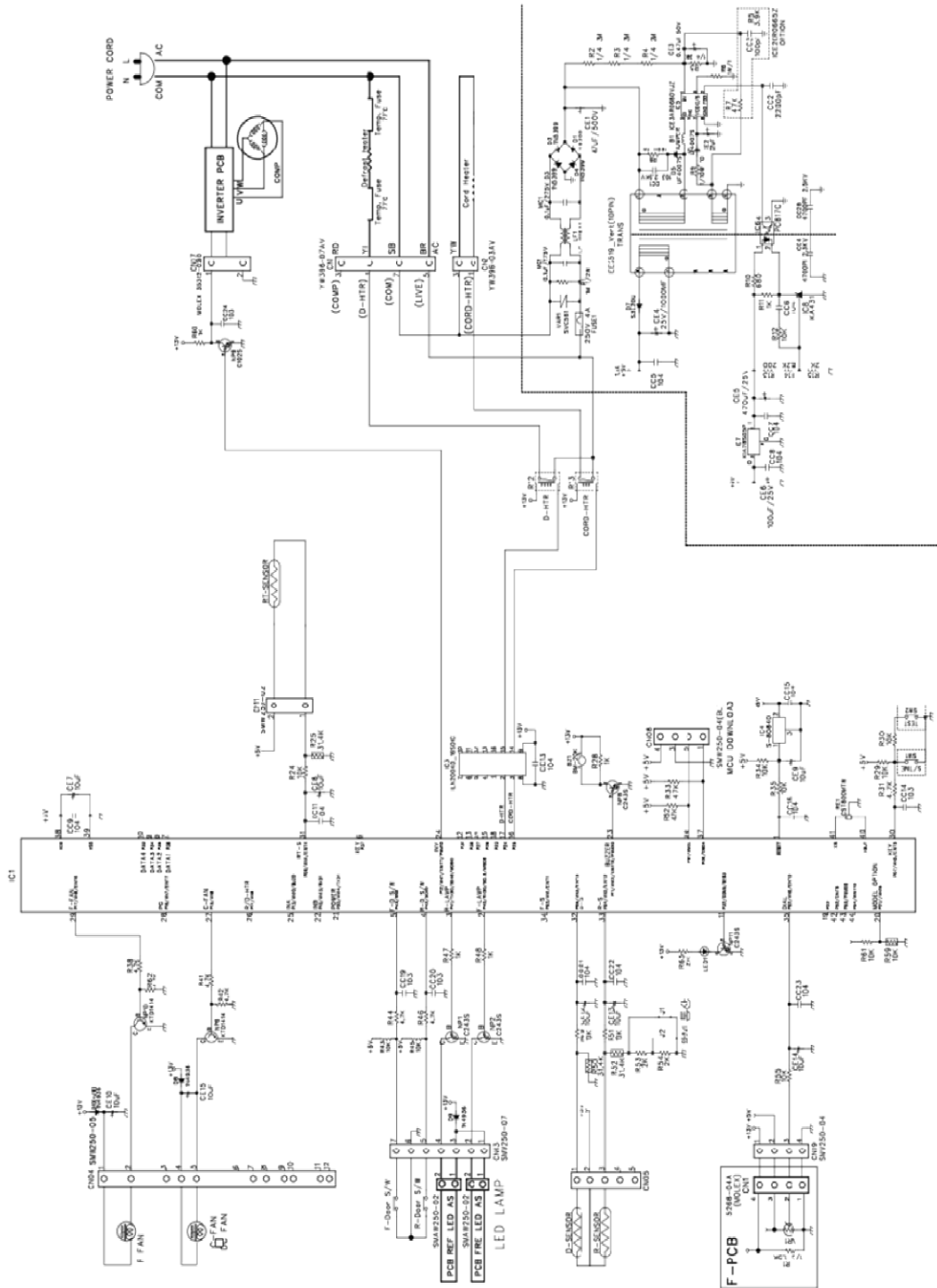

8. SPECIFICATION OF ELECTRIC PARTS

1. COMPRESSOR

	KOREA	UAE
		220V/60Hz
MODEL	LJ88DY	LJ118DY
STARTING TYPE	RSCR	
VOLTAGE	220-240V~50/60Hz	
REFRIGERANT	R-600a(36g)	

2. RELAY

	KOREA	UAE
		230V/50~60Hz
PTC	QPE2-A15MD	QPE2-A15MD
STARTING TYPE	BT60-120	BT69-120

3. RUNNING CAPACITORRELAY

	KOREA	UAE
		230V/50Hz
RATED VOLTAGE	450V	
RATED CAPACITANCE	4 μ F	

4. F-FAN MOTOR





	KOREA	UAE
		220V/60Hz
TYPE NAME	S6112GDF12	S6112CDF09
VOLTAGE	220V/60Hz	230V/50Hz
REVOLUTION	Φ 110 _ 2000 RPM	Φ 110 _ 2000 RPM

5. DEFROST HEATER



	KOREA	UAE
		230V/60Hz
TYPE	SHEATH HEATER	
SPEC.	230V/150W	



9. How To Replace The Parts

9-1. Freezer Louver Part

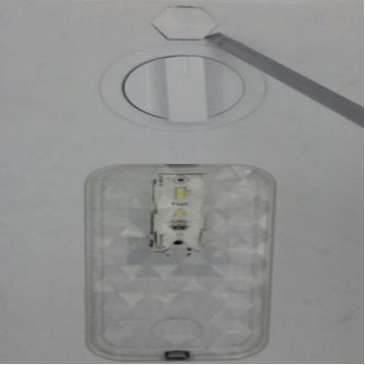
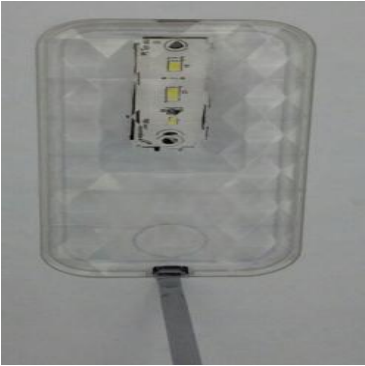
No	Photos	Description
1		<ul style="list-style-type: none">- Remove 'Freezer Shelf' at first.- Remove 2 hole caps with (-) driver.
2		<ul style="list-style-type: none">- Remove 2 screws on 'Freezer Louver'.
3		<ul style="list-style-type: none">- Pull forward the 'Freezer Louver'.
4		<ul style="list-style-type: none">- Disconnect fan motor lead wire.

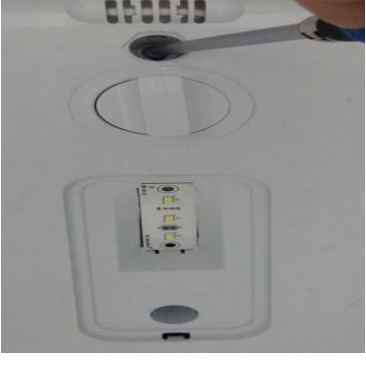
9-2. M/Flow-Duct & lamp

No	Photos	Description
1		- Remove 'hexagonal shaped cap' with (-) driver.
2		- Remove window with(-) driver.
3		- Remove circular shaped cap with (+) driver.
4		- Remove two screws with (+) driver.

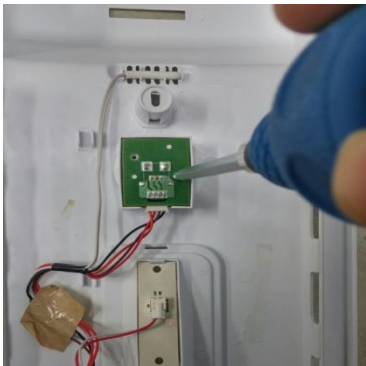
No	Photos	Description
5		<p>-Pull toward the 'M/flow duct'</p>
6		<p>-Pull out the lead wires of 'Lamp' and 'Sensor'</p>
7		<p>-Remove 'INSU M/F DUCT A' and 'INSU M/F DUCT B'</p>
8		<p>--Remove screw with (-) driver</p>

No	Photos	Description
9	 A hand is shown holding two electronic components. On the left is a white PCB dial with a circular hole and several small components. On the right is a green PCB with a lamp LED attached to it. The background shows a white plastic container.	--Detach LAMP LED and PCB DIAL

9-3. MAIN PCB

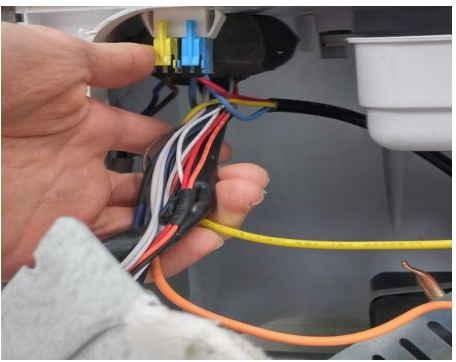
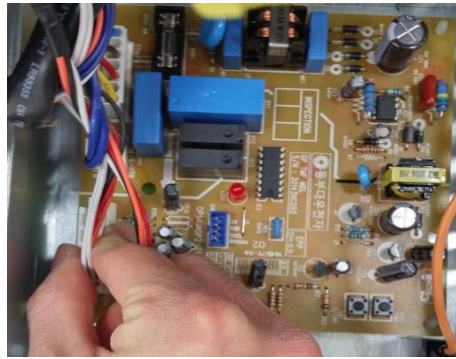
No	Photos	Description
1		- Remove the 2 screws.
2		- Disconnect the lead wires of 'Power cord' and 'compressor relay'.
3		-Remove 'Power Cord' and ' Relay harness'. - Disconnect the housing on the Main PCB'.

10. PCB CONTROL FUNCTION

10-1. SPECIFICATIONS

구분		R-Control							
		240L		13cuft		34~400L		48~510L	
Type		Dial	Dial	Fcp	Dial	Fcp	Dial	Fcp	Dial Inverter
F U N C T I O N S	Super Cooling	-	-	O	-	O	-	O	-
	Eco Mode	-	-	O	-	O	-	O	-
	FCP Lock	-	-	-	-	-	-	-	-
	Buzzer	-	-	O	-	O	-	O	O
E L E C T R O N I C A L P A R T S	Comp	Normal							Inverter
	Heater	Defrost	O	O	O	O	O	O	O
		IL	O	O	O	O	O	O	O
	Motor (DC)	F	(AC)	(AC)	(AC)	(AC)	(AC)	(AC)	O
		C	(AC)	(AC)	(AC)	(AC)	(AC)	(AC)	O
	Sensor	R	O	O	O	O	O	O	O
		D	O	O	O	O	O	O	O
		RT	O	O	O	O	O	O	O
	Door S/W	F	-	-	O	O	O	O	O
		R	O	O	O	O	O	O	O
Lamp	F	-	-	O	O	O	O	O	
	R	O	O	O	O	O	O	O	
Etc.	PCB Location	Machine Room	Back	Machine Room	Machine Room	Machine Room	Machine Room	Machine Room	
	RT-S Location	Dial Type - Hinge, FCP Type – Front PCB Board							

* AC fan motor is interlocked with comp, No PCB controls it.

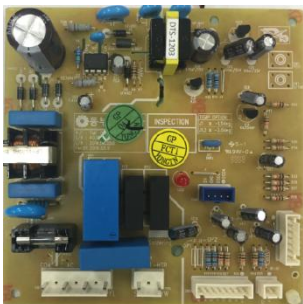

<Dial Type PCB>

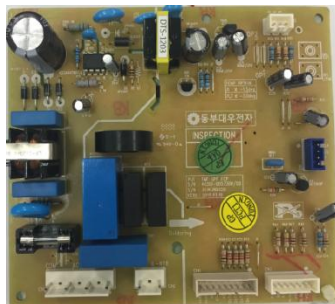

<Fcp Type PCB>

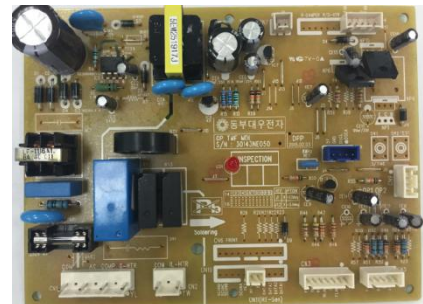

<Dial Inverter Type PCB>

10-2. Control Panel

A. Panel graphic

Dial Type & Dial Inverter Type

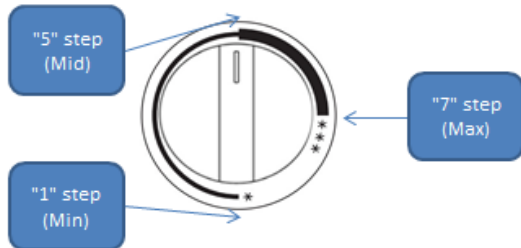

Fcp Type

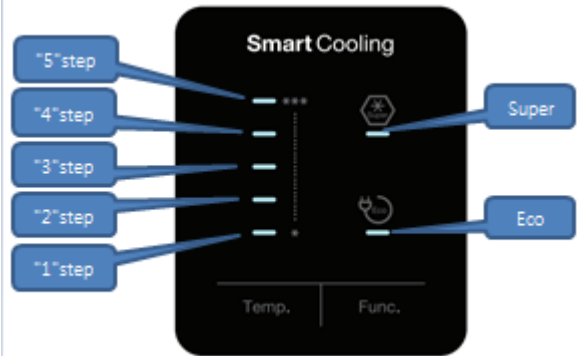

B. How to use Panel

Dial Type & Dial Inverter Type

1. Volume Dial : it controls temperature of refrigerator by step.

- ① How to set temperature : Turn round "Volume Dial Knob".
- ② Temperature setting sequence : 1step → 2step → 3step → 4step → 5step → 6step → 7step
(Min) (Mid) (Max)

Fcp Type

1. Temp Key : it controls temperature of refrigerator by step.

- ① Default : "3step"
- ② How to set temperature : Push "Temp." key
- ③ Temperature setting sequence : 1step → 2step → 3step → 4step → 5step
(Min) (Mid) (Max)

2. Func Key : It controls special Mode of refrigerator.

- ① Default : Mode Off
- ② How to change Mode : Push "Func. " key
- ③ Mode change sequence : Mode Off -> Super Mode -> Eco Mode (repeat)

10-2. Control Pannel

C. Display

Fcp Type

1. Operation

- ① At normal state, display led is on by 100% brightness.
- ② When it passes 1minutes without key operation or door operation, all led is off.
- ③ When there is operation for key or door at LED off condition, led display is back to the normal state.

2. Each MODE Display

1) Normal Mode Display

① Dial Display

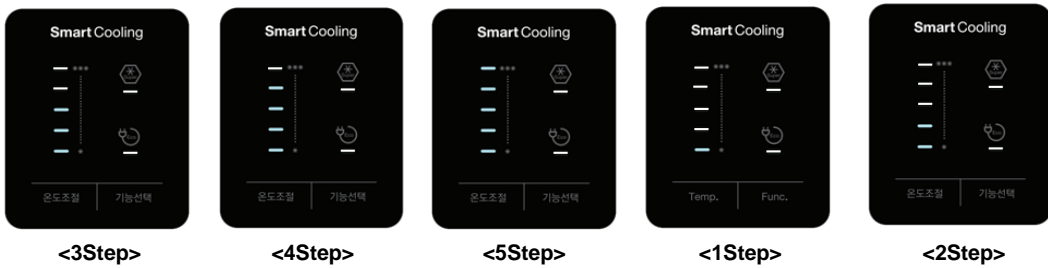

② Special Mode Display



10-3. Freezer Control

* The refrigerator is R-Control system. Freezer temperature is controlled by mechanical.

7-4. Refrigerator Control

Input	Output
<p>* Dial Type & Dial Inverter Type</p> <ul style="list-style-type: none"> - volume dial knob <p>* Fcp Type</p> <ul style="list-style-type: none"> - Front PCB "Temp" Key 	<ul style="list-style-type: none"> - Refrigerator temperature

Dial Type & Dial Inverter Type

A. Refrigerator temperature setting (at 25°C)

Model	Temperature Adjust	1stpe	2stpe	3stpe	4stpe	5stpe	6stpe	7stpe
		Min				Mid		Max
240L	On Point (°C)	7.5	5.2	4.5	3.4	2.7	1.6	0.5
	Off Point (°C)	4.1	1.9	1.2	0.2	-0.6	-1.6	-2.7
34/36/400L	On Point (°C)	5.6	4.1	3.3	2.2	1.5	0.5	-0.2
	Off Point (°C)	2.3	0.8	0.1	-1.0	-1.7	-2.7	-3.4
48/510L	On Point (°C)	6.5	4.4	2.5	1.4	0.7	-0.4	-1.5
	Off Point (°C)	3.1	1.1	-0.8	-1.8	-2.6	-3.6	-4.7
13cu-ft	On Point (°C)	7.9	5.2	4.5	3.4	2.7	1.6	0.1
	Off Point (°C)	4.5	1.9	1.2	0.2	-0.6	-1.6	-3.1

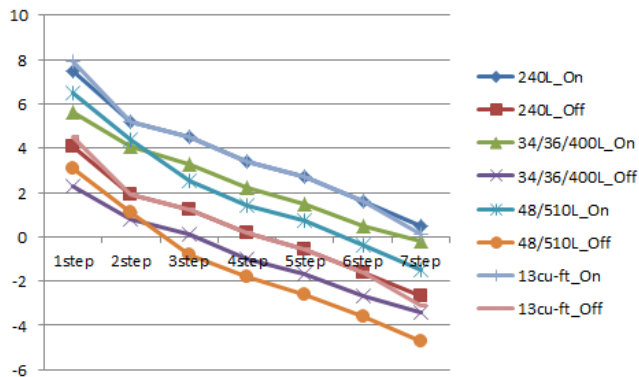

10-4. Refrigerator Control

Fcp Type

A. Dial Default Setting

- "3step"

B. Refrigerator temperature setting (at 25°C)

Model	Temperature Adjust	1step	2step	3step	4step	5step	Super
		Min		Mid		Max	Max
34/36/400L	On Point (°C)	5.6	3.3	1.5	0.5	-0.2	-0.2
	Off Point (°C)	2.3	0.1	-1.7	-2.7	-3.4	-3.4
48/510L	On Point (°C)	6.5	4.4	0.7	-0.4	-1.5	-1.5
	Off Point (°C)	3.1	1.1	-2.6	-3.6	-4.7	-4.7
13cu-ft	On Point (°C)	7.9	4.5	2.7	1.6	0.1	0.1
	Off Point (°C)	4.5	1.2	-0.6	-1.6	-3.1	-3.1

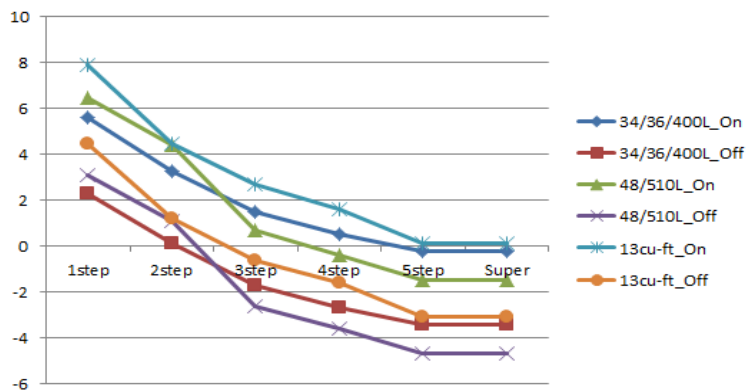

10-5. Special Mode Control

Input	Output
- "Func." Key	- Super Mode - Eco Mode

Fcp Type

A. Special Mode

- 1) Super Mode : For quickly cooling the fridge
- 2) Eco Mode : For saving the power

B. Special Mode Operation

- 1) Super Mode

Operation time	40 minutes
COMP	Continuously On / On, Off control

- 2) Eco Mode

Operation time	Unlimited
COMP	On, Off control

C. Special Mode Release

- 1) Super Mode

- after 40 minutes .

- 2) Eco Mode

- Unlimited

- If open the door within 30 minutes, the Eco Mode is released

10-6. Comp Control

Input	Output
<ul style="list-style-type: none"> - R-Sensor - Short Circuit / Defrost Mode - Elapsed time after comp off 	<ul style="list-style-type: none"> - Comp On/Off Operation

A. General Control

1) if Defrost Mode

Precool	Comp On
Heater On	Comp Off
Pause	Comp Off
Fan_Delay	Comp On

* compressor details operation sees chapter "Defrost Control".

2) if Normal Mode

① R-Sensor Error

- Compressor is controlled of the time by RT-Sensor's range.

② No R-Sensor Error

- Compressor is controlled of the setting On/Off point (reference 7-4)

- R-Sensor \leq Comp Off point -> Comp Off

- R-Sensor $>$ Comp On point -> Comp On

B. Prevention of Compressor Restart

- Compressor doesn't work within 6minutes after Compressor turns off. (This is to protect comp)

ex) Compressor doesn't work after COMP turns off even though R-sensor is on condition

10-7. Defrost Control

Input	Output
- RT / D-Sensor - Comp operation time / Real Time - Comp operation rate / Door Open Time	- Defrost Heater On/Off Operation

A. Initial Defrost

CONTENTS	EXPLANATION								
Inrush conditions	If the temperature at the D-sensor is under 3.5°C, Defrost Mode starts. When D-Sensor Error is happened, the initial defrost function isn't performed .								
Each stage Release conditions	<table border="1"> <tr> <td>PreCool</td> <td>- Exception</td> </tr> <tr> <td>Heater On</td> <td> ① D-Sensor > 13°C ② after 60 minutes </td> </tr> <tr> <td>Pause</td> <td>- after 10 minutes</td> </tr> <tr> <td>Fan_Delay</td> <td> * Dial & Fcp Type – Exception * Dial Inverter Type - after 1 minute </td> </tr> </table>	PreCool	- Exception	Heater On	① D-Sensor > 13°C ② after 60 minutes	Pause	- after 10 minutes	Fan_Delay	* Dial & Fcp Type – Exception * Dial Inverter Type - after 1 minute
	PreCool	- Exception							
	Heater On	① D-Sensor > 13°C ② after 60 minutes							
	Pause	- after 10 minutes							
Fan_Delay	* Dial & Fcp Type – Exception * Dial Inverter Type - after 1 minute								
Mode release	Auto closed after performing functions								

10-7. Defrost Control

B. Normal Defrost Mode

CONTENTS	EXPLANATION	
Inrush conditions	<p>① When total operation time of compressor becomes: 6, 8, 10, 12 hours.</p> <p>◆ Defrost conditions</p> <ul style="list-style-type: none"> i . Any Error happens - R1, D1, RT, dF, dr, F3, C1 Error ii . running rate of COMP (per 2hrs of total operation time) is more than 90%. iii. total door open time is over 2 minutes. <p>② Even if the above condition “Defrost conditions” is not satisfied,</p> <ul style="list-style-type: none"> i . Defrost mode starts immediately when total operation time of COMP is 14hrs. ii . defrost mode starts immediately as long as total time (COMP on time + COMP off time) is 72 hrs. 	
Each stage Release conditions	PreCool	<p>① R-Sensor > Comp Off Point - 3.0℃</p> <p>② after 25 minutes</p>
	Heater On	<p>case 1) D-Sensor Error - after 30 minutes</p> <p>case 2) RT-Mode is “Normal-B” & No open the door & running rate of comp is less than 80% - D-Sensor > 7℃</p> <p>case 3) if Comp Operating time is 6hours and the next Defrost</p> <ul style="list-style-type: none"> ① D-Sensor > 15℃ ② after 70 minutes <p>case 4) Else</p> <ul style="list-style-type: none"> ① D-Sensor > 13℃ ② after 60 minutes
	Pause	<p>case 1) if Comp Operating time is 6hours and the next Defrost - after 20 minutes</p> <p>case 2) Else - after 10 minutes</p>
	Fan_Delay	<p>* Dial & Fcp Type – Exception</p> <p>* Dial Inverter Type - after 1 minute</p>
Mode release	Auto closed after performing functions	

10-7. Defrost Control

C. Low Temp. Defrost Mode

CONTENTS	EXPLANATION	
Inrush conditions	When RT Mode is Low-A,B, “Low Temp. defrost mode” starts immediately as long as total time (COMP on + off time) is 24 hrs. ◆ Mode Maintain conditions i . RT Mode must maintain Low-A,B	
Each stage Release conditions	PreCool	① R-Sensor > Comp Off Point - 3.0℃ ② after 25 minutes
	Heater On	case 1) D-Sensor Error - after 30 minutes case 2) RT-Mode is “Normal-A” & No open the door - D-Sensor > 7℃ case 3) Else ① D-Sensor > 13℃ ② after 60 minutes
	Pause	- after 10 minutes
	Fan_Delay	* Dial & Fcp Type – Exception * Dial Inverter Type - after 1 minute
Mode release	When RT Mode isn;t low A, B, “Low Temp. defrost mode” is turned off immediately. At Low Temp. Defrost Mode, normal defrost mode is performed by satisfying the normal conditions.	

D. High Temp. Defrost Mode

CONTENTS	EXPLANATION	
Inrush conditions	When RT Mode is High-A,B, Defrost mode starts immediately when total operation time of COMP is 24hrs. ◆ Mode Maintain conditions i . RT Mode must maintain High-A,B ii . The door maintains closing. iii . No happened the Error	
Each stage Release conditions	PreCool	① R-Sensor > Comp Off Point - 3.0℃ ② after 25 minutes
	Heater On	① D-Sensor > 13℃ ② after 60 minutes
	Pause	- after 10 minutes
	Fan_Delay	* Dial & Fcp Type – Exception * Dial Inverter Type - after 1 minute
Mode release	When the condition doesn't maintain, “High Temp. defrost mode” is turned off immediately. If “High Temp. defrost mode” is released, normal defrost mode is performed.	

10-7. Defrost Control

* Defrost Flow

* General Defrost Flow

Defrost initial setting -> Precool -> Heater On -> Pause -> Fan_Delay -> Defrost end setting

I. Defrost initial setting

- Each check conditions are initialization.

II. Precool

- 1) Inrush conditions : after 'Defrost initial setting' completion.
- 2) Operation: Comp is On.

III. Heater On

- 1) Inrush conditions : aftr 'Precool' completion.
- 2) Operation : Defrost Heater On.

IV. Pause

- 1) Inrush conditions : after 'Heater On' completion
- 2) Operation : Comp, Defrost Heater Off

V. Fan_Delay

- 1) Inrush conditions : after 'Pause' completion.
- 2) Operation : Comp, C-Fan On

VI. Defrost end setting

- Each check conditions are initialization.

CONTENTS		Precool	HTR On	Pause	FAN Delay
Each stage Release conditions		Refer "Defrost Flow"			
Parts.	Comp, C Fan	On	off	Off	On
	F-Fan	On	off	Off	Off
	Defrost-HTR	Off	On	Off	Off

10-8. Buzzer Control

Input	Output
<ul style="list-style-type: none"> - Front key - Open the door more than 3 minute 	<ul style="list-style-type: none"> - Operate buzzer sound.

Fcp Type & Dial Inverter Type

A. At power on

- After 2 seconds power's on, the buzzer rings 3 times.(sound : bbi~ bbi~ bbi~)

B. Front Key

- Whenever "PCB Control Panel" button's pushed, the buzzer rings.(sound : bbi~ bi~)

C. Test mode entry

- Operate mode changing sound

Mode	Buzzer sound	
As Forced Defrost Mode	Entry	3 short beeps (sound : bbi bbi bbi)
	Release	No sound
Demo Mode	Entry	3 long beeps (sound : bbi~ bbi~ bbi~)
	Release	1 long beep (sound : bbi~)
Jig Mode	Entry	1 short beep (sound : bbi)
	Release	3 long beeps (sound : bbi~ bbi~ bbi~)
Fine Adjustment Mode	Entry	3 long beeps (sound : bbi~ bbi~ bbi~)
	Release	1 long beep (sound : bbi~)

D. Door Open Alarm

- When door opens for 3 minutes, the buzzer rings every 1 minute for 5 minutes. (sound : bbi bbi bbi)

10-9. Door Switch Control

Input	Output
- High / Low Signal	- Door Open / Closes State

A. F/R Door Switch

1) Door Open

- Door Open -> Door Switch On -> Micom Low (0V) signal Input.

2) Door Close

- Door Close -> Door Switch Off -> Micom High (5V) signal Input.

7-10. Lamp Control

Input	Output
- Door Open / Closes State - Lamp On Elapsed time	- Lamp On / Off Operation

A. F/R Lamp

1) Door Switch Error

- F/R Lamp is always off.

2) No Door Switch Error

① Door Open -> Lamp On, After 10 minutes, Lamp is forcibly off.

② Door Close -> Lamp Off.

Dial Type & Dial Inverter Type

*Exception) Line Defrost test Display

- This feature operates only within 120 minutes after the power is turned on.

- When A/S Forced Defrost Mode is entered, R-Lamp operates as follows

① Sensor Error -> R-Lamp is blinks for 30 seconds.

② No Sensor Error -> R-Lamp is forcibly on.

10-11. Cord Heater Control

Input	Output
- RT-Mode	- IL-Heater On / Off Operation

A. Cord-Heater Operation

1) Defrost Mode

- Always maintain the Off state.

2) Else

① RT-Mode is Low-A

- It is controlled by setting time.

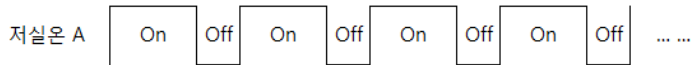

Model	On time	Off time
48/510L	25 minutes	5 minutes
else	20 minutes	10 minutes

② RT-Mode is Low-B

- It is controlled by setting time.

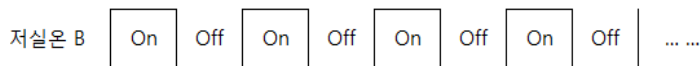

Model	On time	Off time
48/510L	15 minutes	15 minutes
else	15 minutes	15 minutes

③ The other RT-Mode and RT-Sensor Error

- Always maintain the Off state.

10-12. Function Switch Control (Main PCB Location)

Input	Output
- Test Switch - Time Switch	- Short Circuit / Power Saving / As Froced Defrost Mode selection. - Time Pass control

A. Test Switch

- Using Test Switch (Part No. SW2) in the Main PCB, short-circuit mode, the Power Saving mode, As forced defrost mode can be entered.

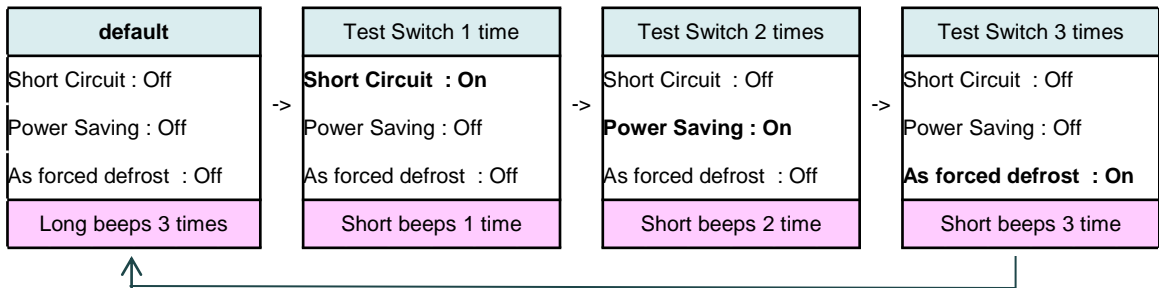

* Pushing the Test Switch for 4 times, Test Mode is become default state.

B. Time Switch

- Using Test Switch (Part No. SW2) in the Main PCB, it can send forcedly the time.

① Short Click the Time Switch (within 1 second)

- 1 min : Click Time Switch one time on MAIN PCB.

② Push the Time Switch (more than 1 second)

- 30 min : If you press FAST KEY continuously, you can reduce 30 minutes on each 2.5 seconds with buzzer.

10-13. Mode Control

**Fcp Type can be entered the mode within 2 hours.
After 2 hours, The mode enterable environment is activated by pushing "TEMP + "FUNC" Key for 10 seconds.**

A. As Forced Defrost Mode

1) How to enter

① How to enter through Key Operation

* Dial Type & Dial Inverter Type

- by pressing "R-Door" switch for continuously and "Volume Dial" is rotated from 1 step to 7 step.

* Fcp Type

- by press "TEMP" button for continuously and "FUNC" button 5 times.

② How to enter through Main PCB Test Switch

- See part of the "Test Switch" in "Function Switch Control" Chapter.

2) Operation

- Process: same as General Defrost Mode except "PRE-COOL"

- Heater is on Initial 60 seconds even though the temp.

(for TEST)

CONTENTS		HTR On	Pause	Fan_Delay
Limited Time		60 minutes	10 minutes	1 minutes
Each stage Release conditions		1. Limited Time 2. D-S > 13°C	Limited Time	Limited Time
Parts.	Comp	Off	Off	On
	Defrost-HTR	On	Off	Off

3) Mode release : Auto closed after performing functions.

B. Short Circuit Test Mode

1) How to enter : See part of the "Test Switch" in "Function Switch Control" Chapter.

(It is available to restart the test and it'll be take 30 hours.)

2) Operation

- COMP & FAN will be on independent of the operating condition.

- There is no defrost mode on this test.

3) Mode release : after the limit test time 30 hours passes.

10-13. Mode Control

C. Error Display Mode

Dial Type & Dial Inverter Type

- 1) To confirm error happens or not, check LED on MAIN PCB
- 2) Operation

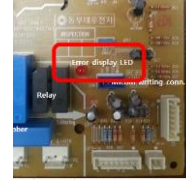

Priority	Error Code	Method to control
1	R1	Main PCB LED 1 time blink
2	RT	Main PCB LED 2 times blink
3	D1	Main PCB LED 3 times blink
4	dr	Main PCB LED 4 times blink
5	dF	Main PCB LED 5 times blink
6	F3	Main PCB LED 6 times blink

- 3) Mode release : Automatic reset become when all error codes return to normal condition.

Fcp Type

- 1) How to enter : by pressing "FUNC" button for continuously and "TEMP" button 5 times.

2) Operation

- To confirm error happens or not, check Display LED
- When No Error, Only Eco LED blink.

- ① R Sensor Open : Fridge Temperature Bar "1"step LED On
R Sensor Short : Fridge Temperature Bar "1"step LED Twinkle

- ② RT Sensor Open : Fridge Temperature Bar "2"step LED On
RT Sensor Short : Fridge Temperature Bar "2"step Twinkle

- ③ D Sensor Open : Fridge Temperature Bar "3"step On
D Sensor Short : Fridge Temperature Bar "3"step Led Twinkle

- ④ F Door Error : Fridge Temperature Bar "4"step Led On

- ⑤ R Door Error : Fridge Temperature Bar "5"step Led On

- ⑥ Cycle Error : Super Led On

- ⑦ Return Defrost Error : Super Led Twinkle

- 3) Mode release : Push "FUNC" 1 time.

Display	고장 증상
Fridge Temperature Bar "1"step LED On	R Sensor Open
Fridge Temperature Bar "1"step LED Twinkle	R Sensor Short
Fridge Temperature Bar "2"step LED On	RT Sensor Open
Fridge Temperature Bar "2"step LED Twinkle	RT Sensor Short
Fridge Temperature Bar "3"step LED On	D Sensor Open
Fridge Temperature Bar "3"step LED Twinkle	D Sensor Short
Fridge Temperature Bar "4"step LED On	F Door Error
Fridge Temperature Bar "5"step LED On	R Door Error
Super LED On	Cycle Error
Super LED Twinkle	Return Defrost Error

10-13. Mode Control

Fcp Type

D. Fine Adjustment Mode

1) How to enter : by pressing "TEMP" buttons for 10 seconds.

2) Operation

- When enter the mode, Only Super LED blink

- On / Off point is varied by fine adjustment value.

DISPLAY	Eco	Fridge Temperature Bar					fine adjustment value
		"1"step	"2"step	"3"step	"4"step	"5"step	
LED ON/OFF		■	■	■	■	■	-5
		■	■	■	■	□	-4
		■	■	■	□	□	-3
		■	■	□	□	□	-2
		■	□	□	□	□	-1
		□	□	□	□	□	0
		■	□	□	□	□	1
		■	■	□	□	□	2
		■	■	■	□	□	3
		■	■	■	■	□	4
		■	■	■	■	■	5

■ : LED On
□ : LED OFF

3) Mode release : When it passes 5seconds without key operation, auto closed the mode.

E. Demo Mode

1) How to enter : by pressing "FUNC" buttons for 10 seconds.

2) Operation

- All electronic compartments are off except "Display Panel".

- "1"step -> "2"step -> "3"step -> "4"step -> "5"step -> Super -> Eco -> All Led Off

- When "DEMO" mode works, led lamps will be on as next steps.

3) Mode release : by pressing "FUNC" buttons for 10 seconds

10-14. Control of R-sensor OFF Point

Input	Output
- J1, J2 On Main PCB	- Control Resistance of R sensor OFF Point

A. LOW COOLING OPTION

(1) Adjust R-Sensor off point (Max 3.0deg down)

(2) the following actions are recommended for service.

- ① Resistance (R52) : Default resistance (31.4Kohms)
- ② Resistance (R53) : Cut the "J1" off to reduce basic resistance by 1.5°C. (2KΩ up)
- ③ Resistance (R54) : Cut the "J2" off additionally to reduce basic resistance by 1.5°C. (total 4KΩ up)

ex) $R52 = \text{R-SENSOR OFF point}$

$R52 + R53 = \text{R-SENSOR OFF point} - 1.5^{\circ}\text{C}$

$R52 + R53 + R54 = \text{R-SENSOR OFF point} - 3^{\circ}\text{C}$

Dial Type

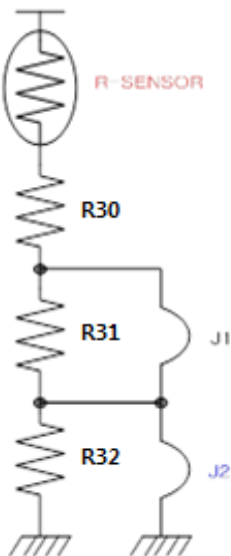

Fcp Type & Dial Inverter Type

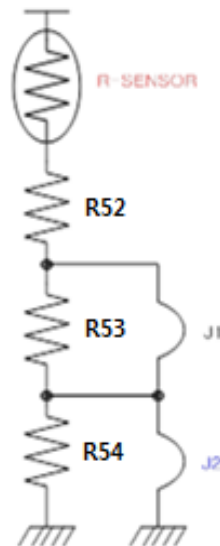

10-15. Error Code

A. R-Sensor Error

- 1) Error Code : R1
- 2) Condition :
 - ① R-Sensor Open : It happens when R-Sensor is sensing less than -45°C
 - ② R-Sensor Short : It happens when R-Sensor is sensing more than 50°C
- 3) release : When R-Sensor is sensing from -45 to 50°C .

B. RT-Sensor Error

- 1) Error Code : Rt
- 2) Condition :
 - ① RT-Sensor Open : It happens when RT-Sensor is sensing less than -45°C
 - ② RT-Sensor Short : It happens when RT-Sensor is sensing more than 50°C
- 3) release : When RT-Sensor is sensing from -45 to 50°C .

C. D-Sensor Error

- 1) Error Code : D1
- 2) Condition :
 - ① D-Sensor Open : It happens when D-Sensor is sensing less than -45°C
 - ② D-Sensor Short : It happens when D-Sensor is sensing more than 50°C
- 3) release : When D-Sensor is sensing from -45 to 50°C

D. R-Door Error

- 1) Error Code : dr
- 2) Condition : It happens when the system senses R-Door opens more than 1 hour
- 3) release : If R-Door switch (close) is sensed, the error is terminated automatically

E. F-Door Error

- 1) Error Code : dF
- 2) Condition : It happens when the system senses F-Door opens more than 1 hour
- 3) release : If F-Door switch (close) is sensed, the error is terminated automatically

F. Cycle Error

- 1) Error Code : C1
- 2) Condition : When D-Sensor is more than -5°C , Comp operates over 3 hours
- 3) release : When Comp is off, D-Sensor is less than -5°C .

* When D-Sensor is normal operation, "C1" Error can be checked.

G. Return Defrost Error

- 1) Error Code : F3
- 2) Condition : Return to next limit defrost time.
- 3) release : Completion of defrost returned by D-Sensor.

* When D-Sensor is normal operation, "F3" Error can be checked.

10-16. Constraint

A. H/W Constraint

- According to the local environment and Micom Spec, hardware function can be constrained.

B. S/W Constraint

- Depending on the amount of memory and CPU performance may be different from the S / W performance results
- When operating with other and different applications, it may be deteriorated.

11. EXPLODED VIEW AND PART LIST

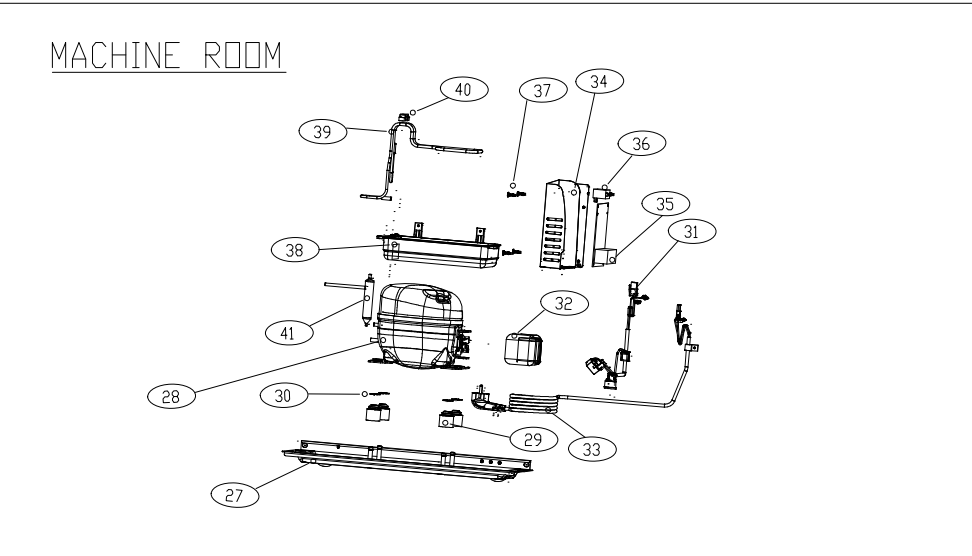
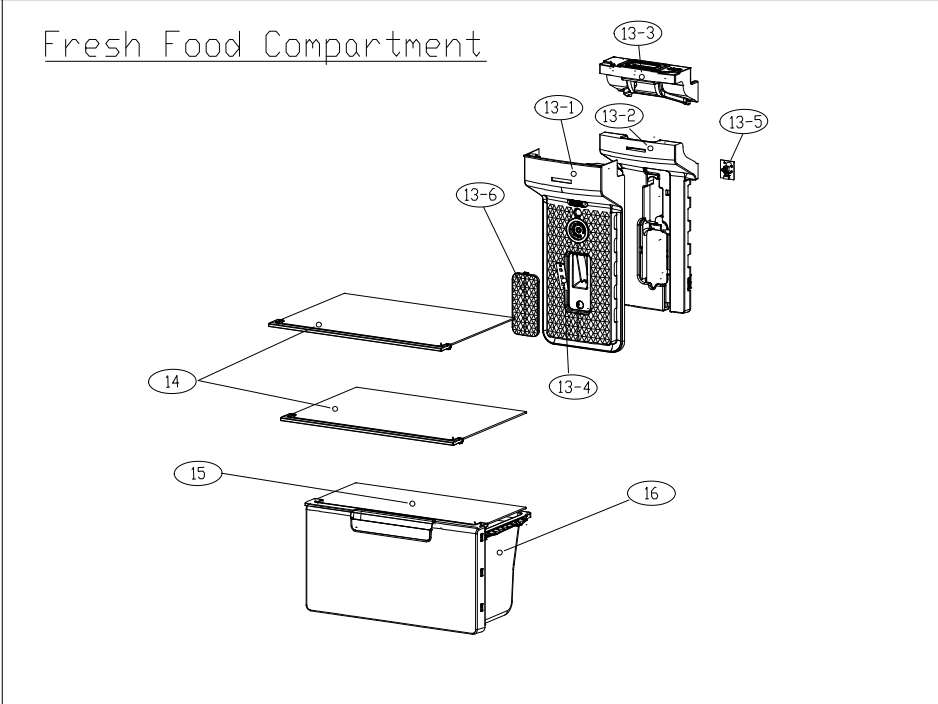
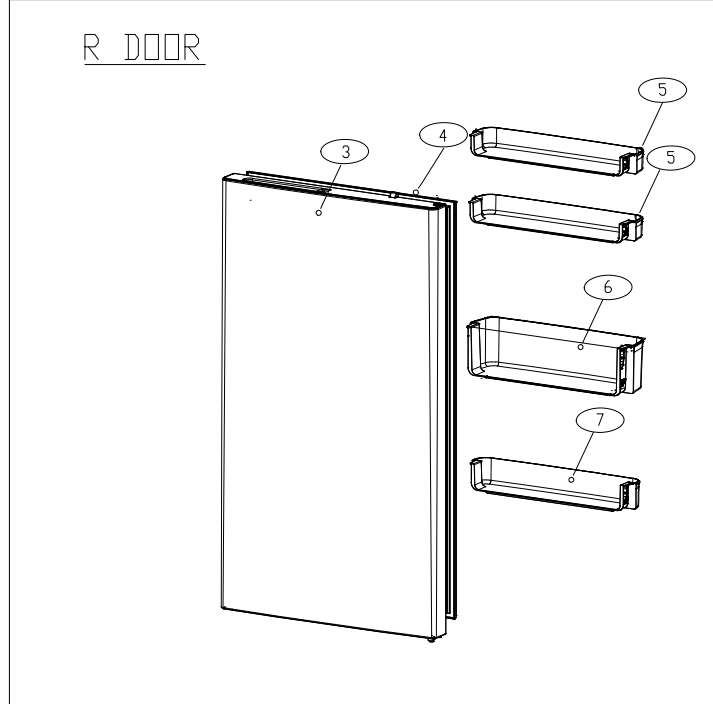
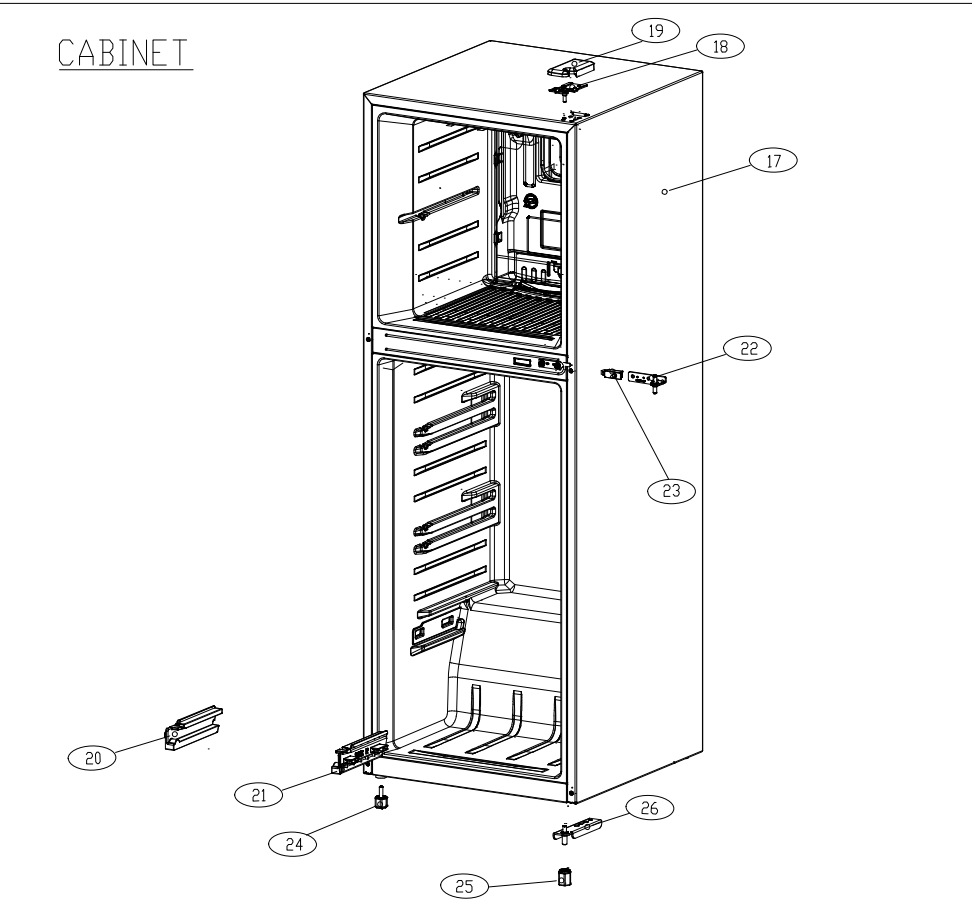
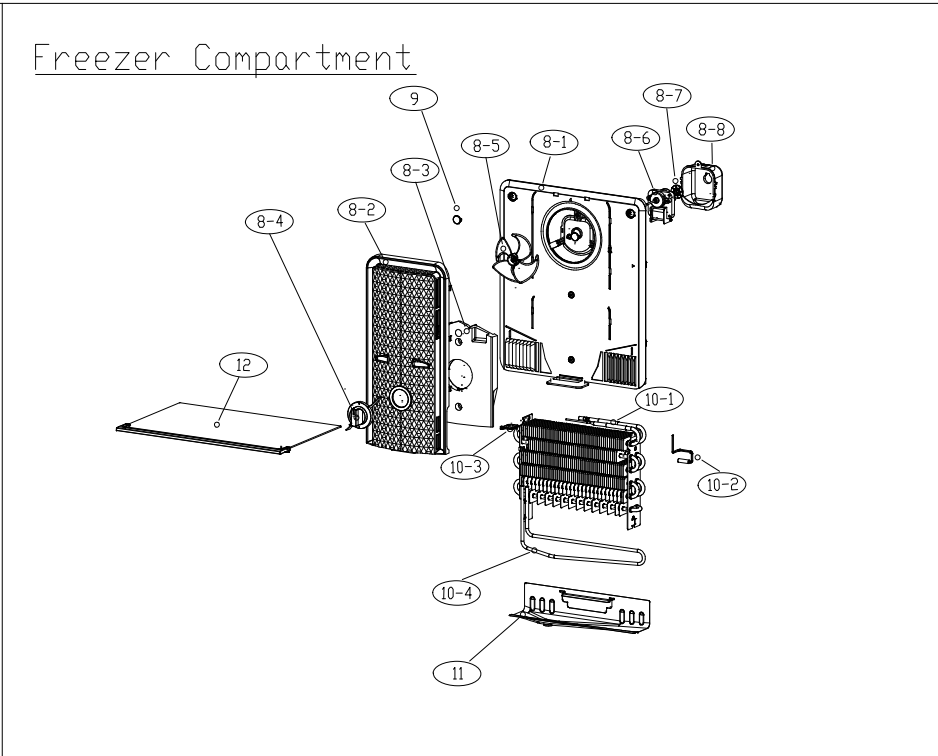
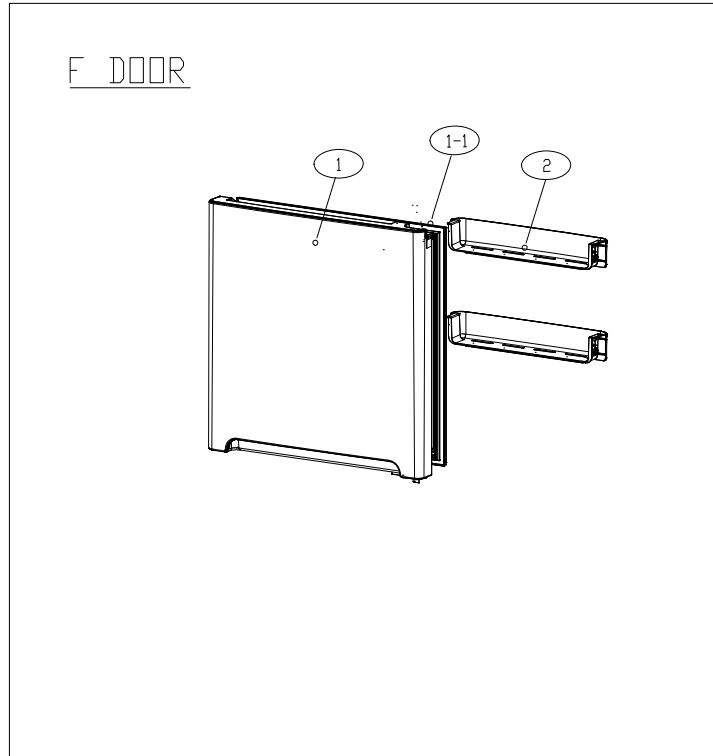

NO	PART NUMBER	PART NAME	PART DESCRIPTION	Q'ty	Remark
1	30100-0094800	ASSY F DR	FR-G242PW	1	
1-1	30123-0009600	GASKET F DR AS	PVC-S RGE24	1	
2	30190-0019700	POCKET F	GPPS MF21-301 RGE24	2	
3	30100-0094900	ASSY R DR	FR-G242PW	1	
4	30123-0009700	GASKET R DR AS	PVC-S RGE24	1	
5	30190-0019800	POCKET R *T	GPPS MF21-301 RGE24	2	
6	30190-0020000	POCKET R JUMBO	GPPS MF21-301 RGE24	1	
7	30190-0019900	POCKET R *U	GPPS MF21-301 RGE24	1	
8	30189-0011400	LOUVER F AS	220V/60HZ RGE24	1	
8-1	3018934700	LOUVER F	PP J370A WH1802A RGE24	1	
8-2	301149FH00	COVER F FAN	PP J370A WH1802A RGE24	1	
8-3	30133-0018400	INSU F FAN COVR	EPS ZKF-401 RGE24	1	
8-4	3013417100	KNOB F CONTL	HIPS 1X4 RGE48	1	
8-5	3011802700	FAN AS	FAN(OD110)+CLAMP	1	
8-6	3015925500	MOTOR F FAN	220V 60Hz 2000RPM	1	
8-7	3010107100	ABSORBER F MOTR	ABSORBER F MOTR NBR	2	
8-8	3012045400	FIXTURE MOTR *B	PP J370A, FRE-361	1	
9	3010924600	CAP F LUVR	CAP F LOUVER HIPS T2.3	2	
10	60170-0008000	EVA AS	RGE24	1	
10-1	60170-0008100	EVA SAS	PIPE+FIN AS RGE24	1	

10-2	60148-0007600	SENSOR RT AS	PVC None, L2060 RGE36	1	
10-3	4016N03280	CABLE TIE	DA-140	2	
10-4	60128-0010700	HEATER SHEATH AS	150W/AC230V RGE24	1	
11	30125-0029600	GUIDE DRN	SAZCC(GL) T0.35 RGE24	1	
12	30178-0022300	SHELF F AS	GLASS+DECO RGE24	1	
13	30114-0069000	COVER M/FLOW DUCT AS	RGE24	1	
13-1	30114-0069200	COVER M/FLOW DUCT	PP J370A WH1802A RGE24	1	
13-2	30133-0018500	INSU M/FLOW DUCT A1	EPS ZKF-401 RGE24	1	
13-3	30133-0018700	INSU M/FLOW DUCT A2	EPS ZKF-401 RGE24	1	
13-4	30136A1600	LAMP LED AS	3LED,66*20*1.6T,DC12V	1	
13-5	30143KW260	REF PCB SUB ASSY	BALLISTA VOLUME	1	
13-6	30155-0016200	WINDOW R LAMP	GPPS MF21-301 RGE24	1	
14	30178-0022400	SHELF R AS	RGE24 GLASS+DECO	2	
15	30178-0023600	SHELF V/CASE AS	GLASS+DECO RGE24	1	
16	30111-0037500	CASE VEGETB AS	CASE+WINDOW RGE24	1	
17	30100-0094601	ASSY CAB URT	RGE24	1	
18	30129-0017600	HINGE *T AS	HI+SHAFT MFZN RGE24	1	
19	30114-0068500	COVER HI *T	PP J370A WH1802A RGE24	1	
20	30125-0029800	GUIDE V/CASE *L	PP J370A WH1802A RGE24	1	
21	30125-0029900	GUIDE V/CASE *R	PP J370A WH1802A RGE24	1	
22	30129-0017500	HINGE *M AS	HI+SHAFT MFZN RGE24	1	
23	3011777100	DOO SW AS	WDS001C-01+COVER	1	

24	3012106500	FOOT ADJ *L AS	PP+INSERT	1	
25	3012106600	FOOT ADJ AS	PP J370A + M10 NUT	1	
26	3012939300	HINGE *U AS	HINGE *U AS FRE-361	1	
27	30103-0025700	BASE COMP AS	BASE+BOLT REG24	1	
28	39561LJ96A	COMP	COMPRESSOR LJ88DY	1	
	39561LJC6A	COMP	COMPRESSOR LJ118DY	1	
29	3010101600	ABSORBER COMP	ABSORBER COMP NBR	4	
30	3016007000	SPECIAL WASHER	SBHG T0.6	4	
31	60181-0011101	SWITCH P RELAY AS	REG24 LOCK TYPE	1	
32	3811402600	COVER RELAY	FRE-343	1	
33	60113-0006604	CORD POWER AS	내수향 LP-33 ,250V 16A (Fuse 250V 9A) 호루라기 RGE48,51	1	
	60113-0006603	CORD POWER AS	UK LP-61L/BS-1363 ,250V 13A 호루라기 RGE48,51	1	
	60113-0006600	CORD POWER AS	EU향 LP-33 , 호루라기 RGE48,51	1	
	60113-0006601	CORD POWER AS	MEXICO향 127V , 호루라기	1	
	60113-0006605	CORD POWER AS	Australia ,LP-23A ,250V 10A 호루라기	1	
34	30105-0028100	BOX M/PCB	SGCC T0.4*270*250 RGE24	1	
35	30143NC050	REF PCB BOARD	FR-1 122X122-1.6T	1	
36	3016407040	CAPACITOR RUN	450V,4UF(WIRE HOUSING,CQC)	1	

37	3012047600	FIXTURE M/PCB	NYLON,10R	4	
38	30111-0037400	CASE VAPORI	DUCT1 C1220-0 L1105, FOR LJ88DY COMP RGE24	1	
39	60144-0021800	PIPE DELI CONN AS	DUCT1 C1220-0 L1105	1	
40	3010101330	ABSORBER PIPE A2	NBR 15G	3	
41	3016808231	DRYER AS	10G, SINGLE TUBE	1	