

S/M No : AKL0108EF0

Service Manual

Car Audio

MODEL : AKL-0108 Series

■ 0106 Series

- AKL-0106A

■ 3010 Seires

- AKL-3010RC
- ACL-3010RC
- AKL-3010RDS
- AKL-3010C
- AKL-3010

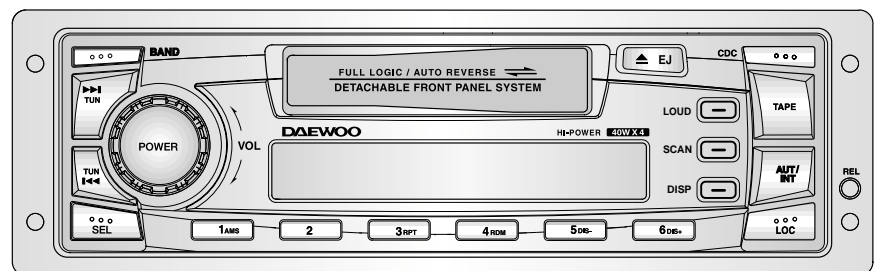
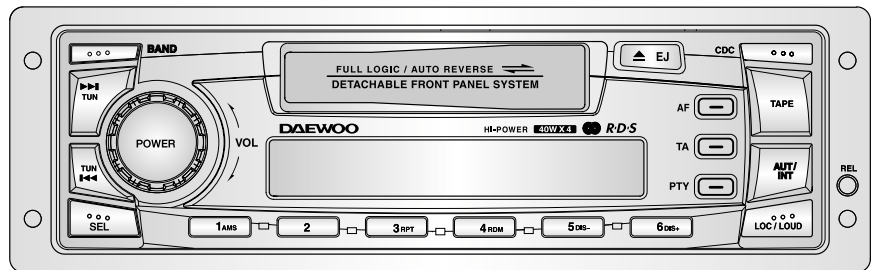

- 4-Channel high Power (40W x 4Ch)
- Electronic Tuning
- Electronic Volume/Bass/Treble/Balance/Fader Control
- Local/DX Switch
- Loudness Control
- Logic cassette Player
- Detachable Face for Anti-Theft
- 10 CD-changer control(option)

DAEWOO ELECTRONICS CO., LTD

<http://svc.dwe.co.kr>

Mar. 2001

TABLE OF CONTENTS

1. PRODUCT SPECIFICATIONS	1
2. LINE DRAWING	2
3. ADJUSTMENTS	3
4. SCHEMATIC DIAGRAM	7
5. PARTS LOCATION ON P.C.BOARD	8
6. OVERALL EXPLODED VIEW & PARTS LIST	11
7. DECK MECHANISM EXPLODED VIEW & PARTS LIST	12
8. PARTS LIST	15
9. FUNCTION OF MICOM IC	18
10. IC BLOCK DIAGRAM	24
11. LIQUID CRYSTAL DISPLAY	28
12. OUTPUT CONNECTION DESCRIPTIONS	29

1. PRODUCT SPECIFICATIONS

AUDIO SECTION

Maximum output power	: 40watts per channel into 4 ohms.
Load impedance	: 4 ohms or 8 ohms
Total harmonic distortion	: Less than 10% at 12 watts
Frequency response	: 100Hz(± 3 dB), 10kHz(-5 ± 3 dB)
Control Bass/Treble	: 10 ± 3 dB at 100Hz/10kHz

TAPE SECTION

Track format	: 2-track / 2-channel system
Tape speed	: 4.75cm/sec
Wow / Flutter	: 0.35%max. (WRMS)
Frequency response	: 63Hz ~ 10kHz (± 3 dB) normal (LH)tape
Signal to noise ratio	: 50dB
Channel separation	: 35dB

TUNER SECTION

(FM) Tuning range	: 87.5 to 108MHz
Sensitivity	: 10dBuV
Stereo separation	: 30dB
Signal to noise ratio	: 55dB
Frequency range	: 87.5 ~ 108MH
	: 522 to 1620KHz at Europe
(MW) Tuning range	: 530 to 1710kHz at U.S.A
Sensitivity	: 28dBuV
Signal to noise ratio	: 50dB
Frequency range	: 522 ~ 1620KHz
Channel space	: 9KHz (or 10KHz at U.S.A)
(LW) Tuning range	: 144 to 288KHz
Usable Sensitivity	: 40dBuV

GENERAL

Power requirements	: DC 13.8V (10.8 ~15.6V allowable) Negative ground
Spdaker impedance	: 4 or 8 ohm
Output power	: Maximum 40Wx4Ch.
Current consumption	: 10A
Dimension (W x H x D)	: 178 x 50 x 156 mm
Chassis size	: 195 x 64 x 14.6 mm
Weight(Net)	: 1.75Kg

Design and specifications are subject to changes for improvements without notice.

2. LINE DRAWING

2-1. FRONT SIDE

■ AKL-3010RC

- RDS Function
- 4-Channel high Power (40W x 4Ch)
- Electronic Tuning
- Electronic Volume /Bass /Treble /Balance /Fader Control
- Local/DX Switch
- Loudness Control
- Logic cassette Player
- Detachable Face for Anti-Theft
- 10 CD-changer control

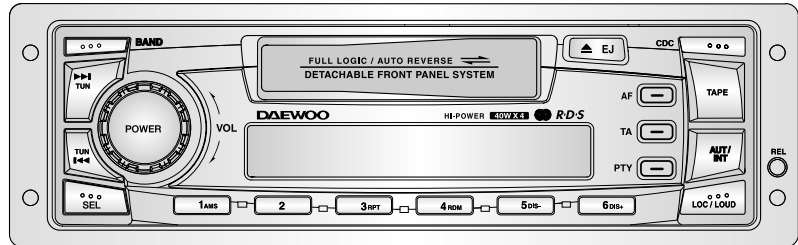

■ AKL-3010C

- Basic Function
- 4-Channel high Power (40W x 4Ch)
- Electronic Tuning
- Electronic Volume /Bass /Treble /Balance /Fader Control
- Local/DX Switch
- Loudness Control
- Logic cassette Player
- Detachable Face for Anti-Theft
- 10 CD-changer control

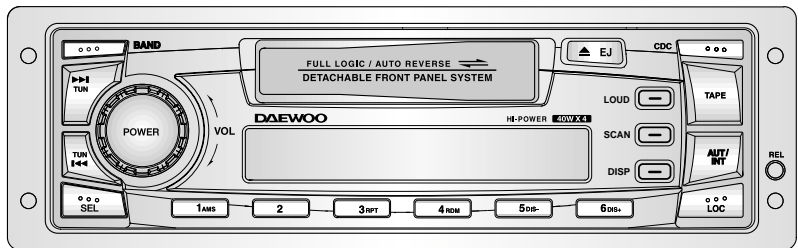

2-2. REAR SIDE

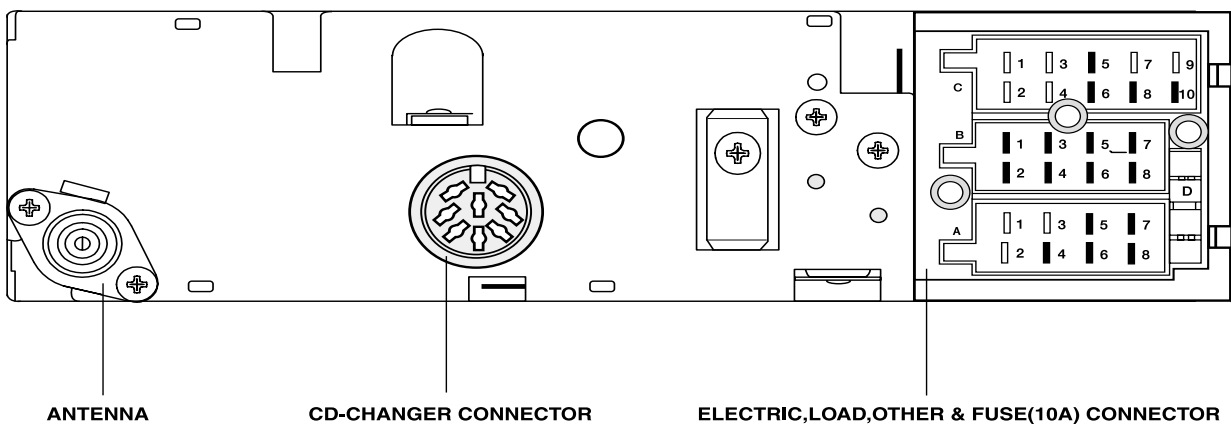

3. ADJUSTMENTS

3-1. TUNER MODULE ADJUSTMENT LOCATIONS

- CAT-7 (3 Band)

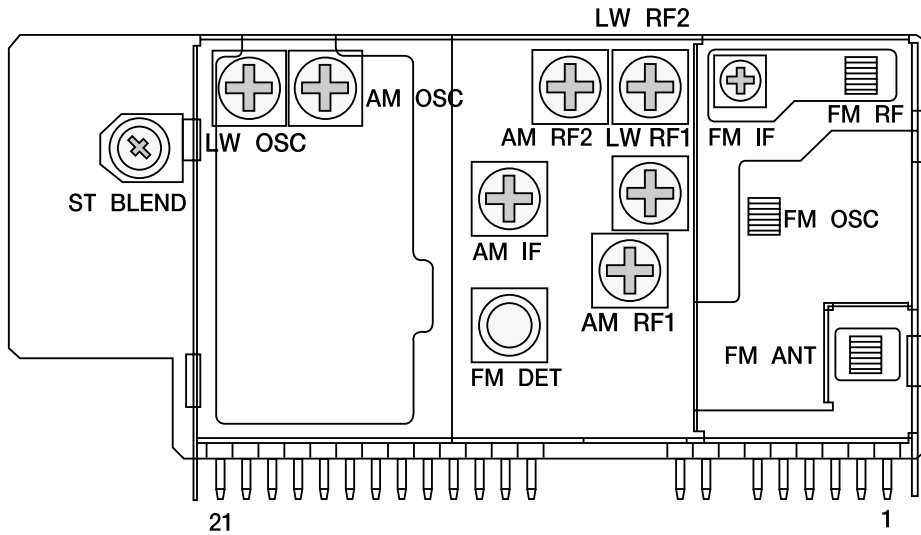

- CAT-6 (2 Band)

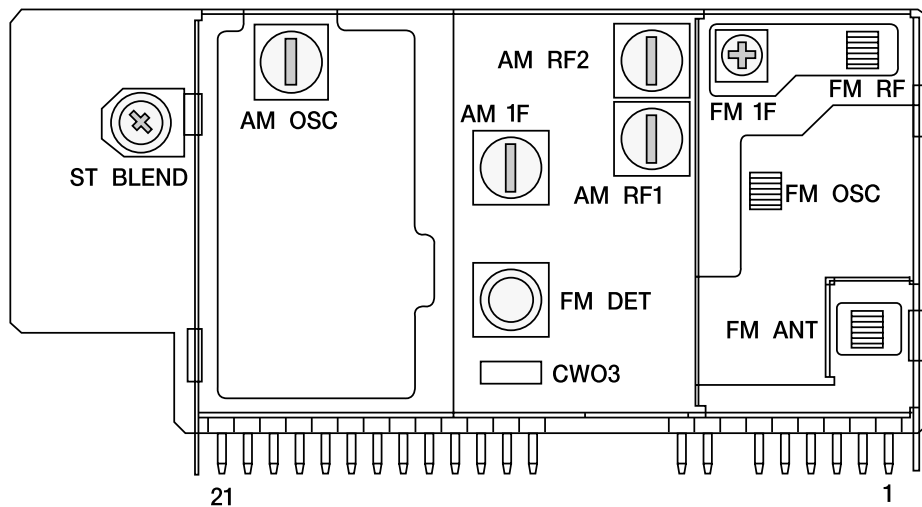

3-2. MW / LW ADJUSTMENT METHOD

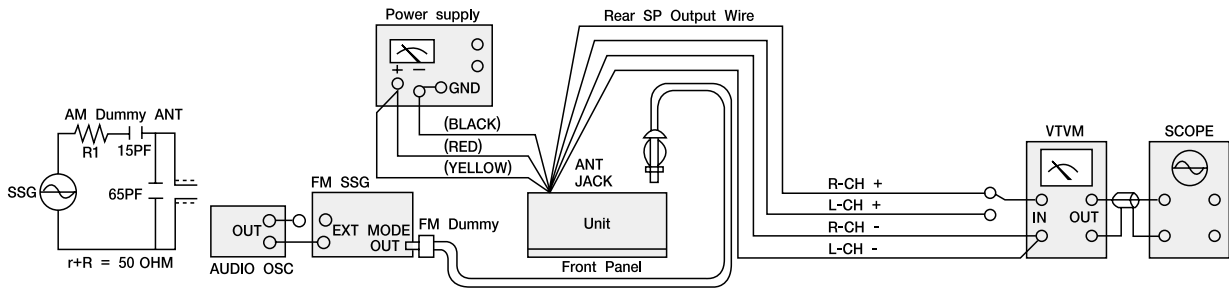

STEP	ALIGNMENT	TUNING	TEST POSITION	SSG FREQUENCY	ALIGNMENT	INDICATOR
MW	Band Covering Range	522 KHz	V.T point of AM Board	522 KHz	AMOSC	MAXIMUM
		1620 KHz		1620 KHz	-	7.6V
	IF	522 KHz	Output	450 KHz	AMIF	MAXIMUM
	TRACKING	603 KHz	Output	603 KHz	AMRF1 AMRF2	MAXIMUM
1404 KHz		Output	1404 KHz	AMRF1 AMRF2	MAXIMUM	
LW	Band Covering Range	144 KHz	-	144 KHz	LWOSC	MAXIMUM
	TRACKING	220 KHz	Output	220 KHz	LMRF1 LMRF2	MAXIMUM

3-3. FM ADJUSTMENT METHOD

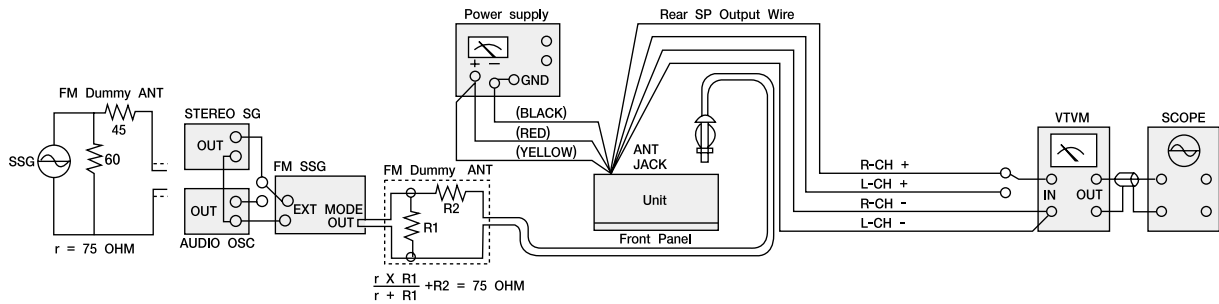

STEP	SUBJECT	FEED SIGNAL		MEASURE OUTPUT	ADJUST POINT	ADJUSTMENT
		FROM	TO			
1	IF adjust	98.1 MHz, ANT input 60dBu, 1kHz (30% MOD) FM SSG	ANT jack and GND	The voltage between CW03	FM DET	Adjust for 0V 0.05V
2	MPX IC Separation Control	98.1 MHz, ANT input 40dBu, 1kHz (L+R=45% L-R=45% PILOT=10% MOD)	ANT jack and GND	L or R CH SP. output wire VTVM and Scope	ST BLEND	L, R separation 8dB

3-4. TAPE ADJUSTMENT METHOD

- NOTE :**
1. Clean the playback head before adjustment
 2. Prepare the test tape MTT-114 or equivalent
 3. Balance, Fader, Bass & TrebleCenter position. Volume adjusted to 2Volts.

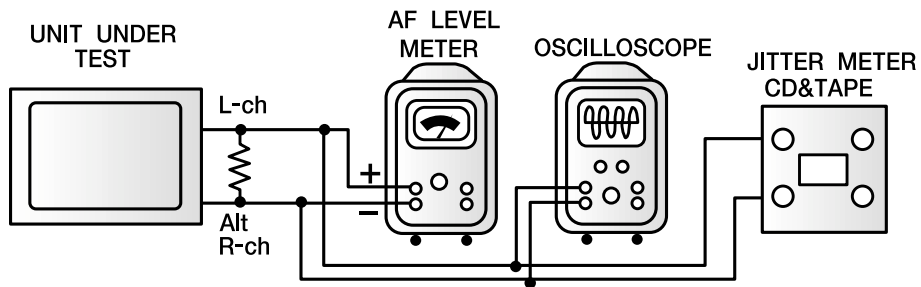

STEP	DESCRIPTION	TEST TAPE	TEST POINT	ADJUSTMENT POINT	ADJUSTMENT
1	Head azimuth adjustment	MTT-114N or equivalent	Speaker Output	Head azimuth adjustment screw	Turn the azimuth screw to obtain maximum level
2	Tape Speed	MTT-114N or equivalent	Speaker Output	Tape Speed adjustment	Adjust for 3010-3020Hz

Note :

<u>dBu</u>	<u>uV</u>	<u>dBu</u>	<u>uV</u>
17	5.0	33	44.6
16	6.31	35	56.2
30	31.6	45	178

NOTE : Antenna signal is used.

1. For Signal Generator with readings in EMF(Open type) add 12dB (6dB for the "Dummy" and 6dB for EMF-reading).
2. For Signal Generator with reading in dBm add 6 dB for "Dummy"

4. SCHEMATIC DIAGRAMS

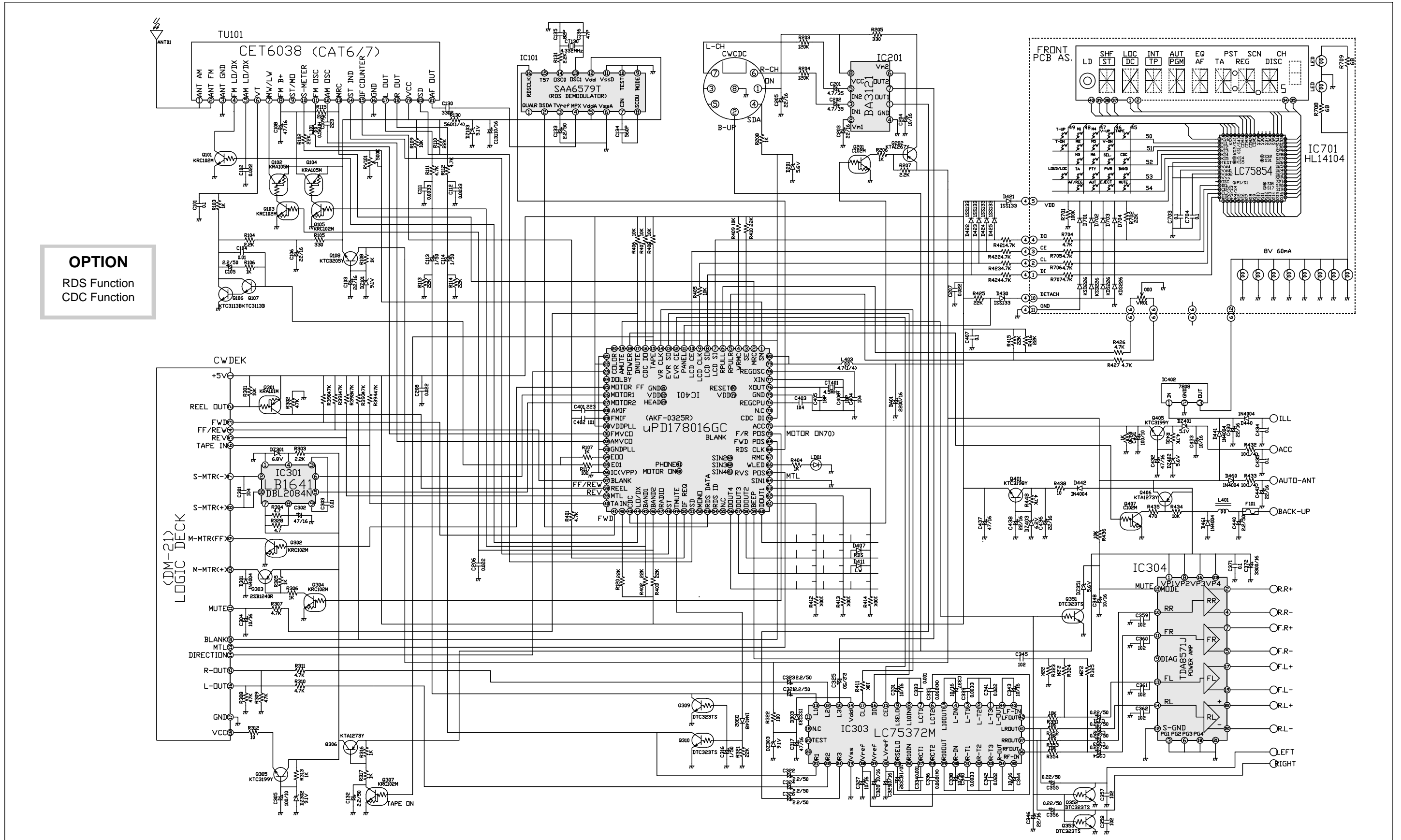

OPTION
RDS Function
CDC Function

5. PARTS LOCATION ON P.C. BOARD

5-1. PCB MAIN

PART SIDE

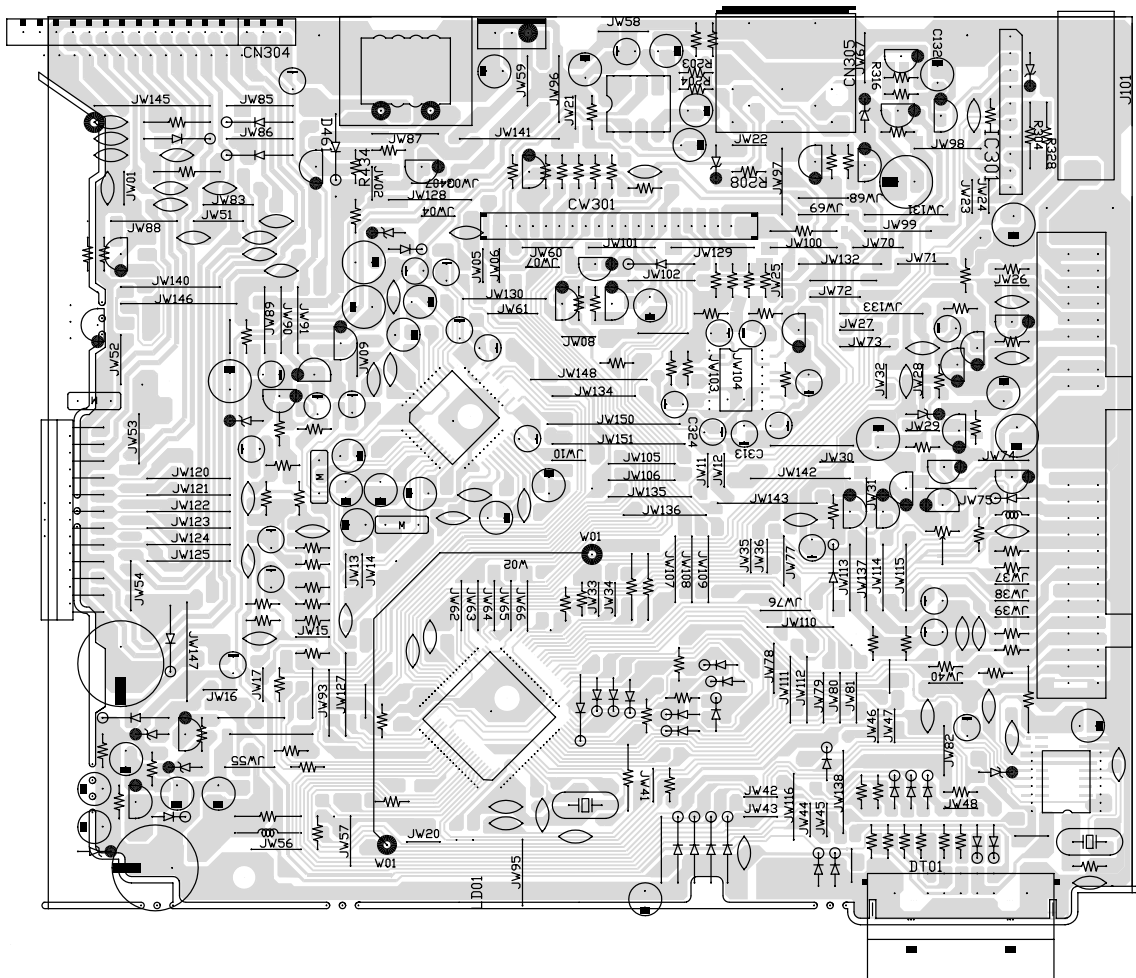

PARTS LOCATION ON P.C. BOARD for AKL-3010Series & AKL-0106Series

BOTTOM SIDE

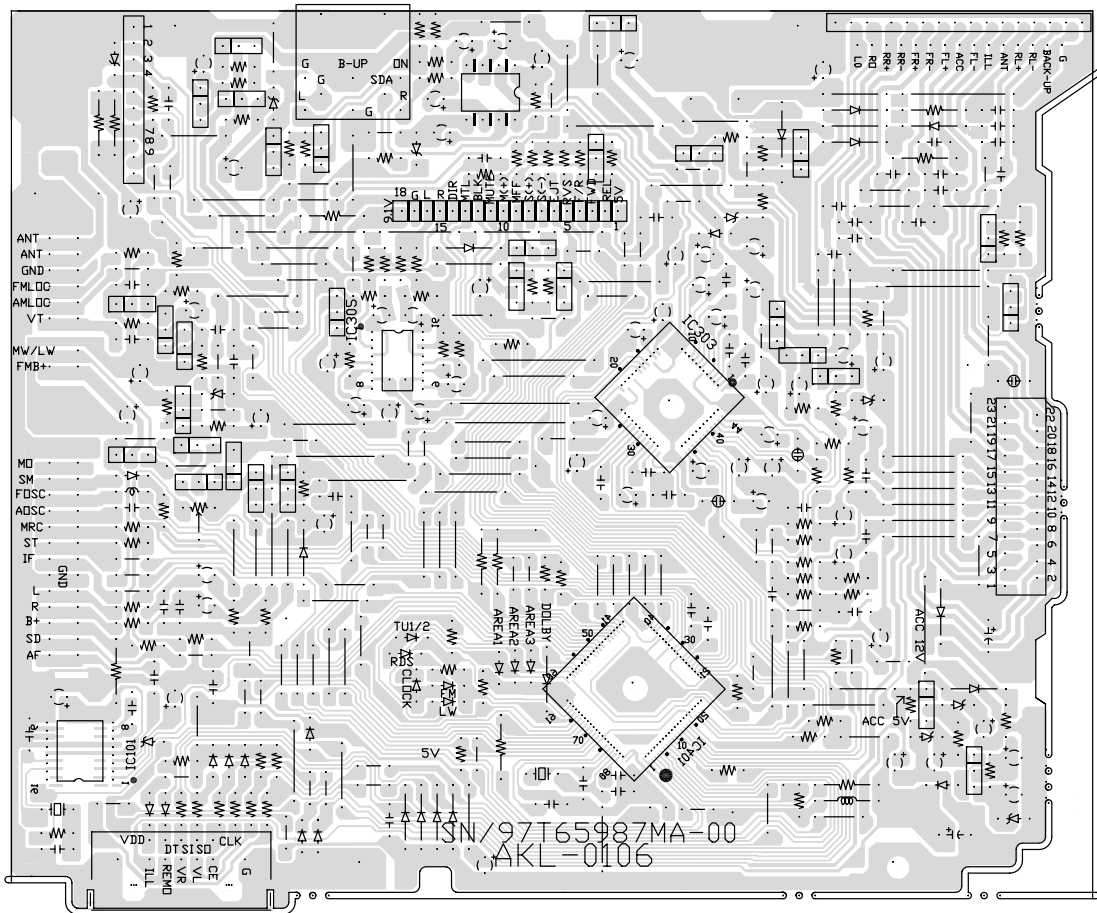

5-2. PCB FRONT

PART SIDE

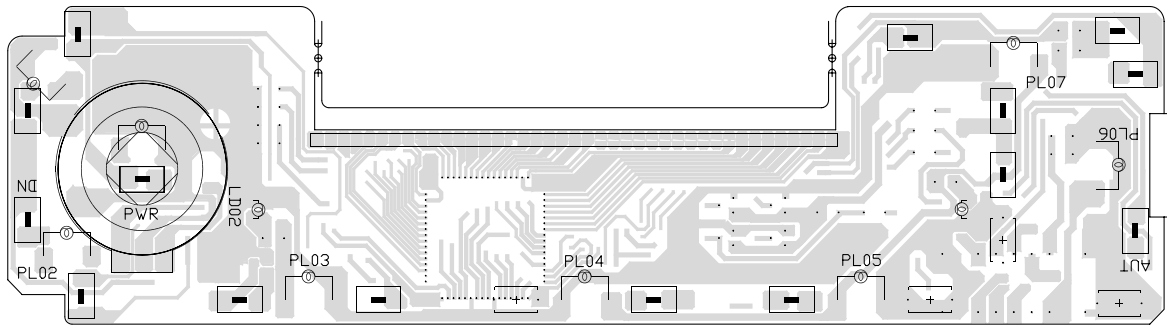

BOTTOM SIDE

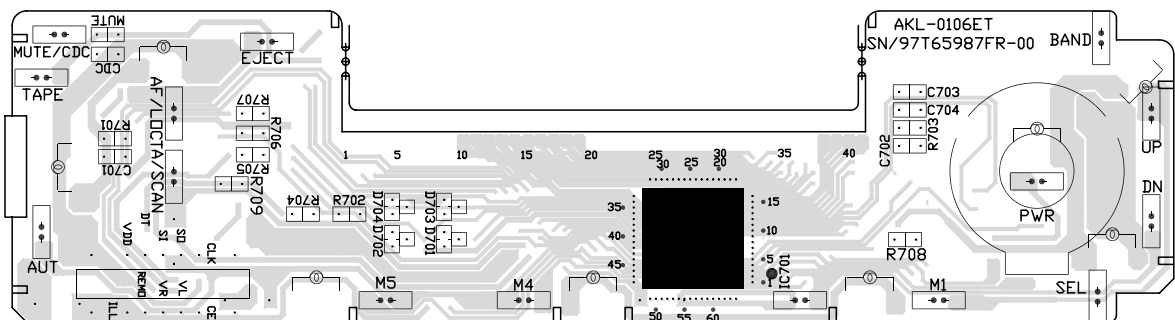

6. OVERALL EXPLODED VIEW & PARTS LIST

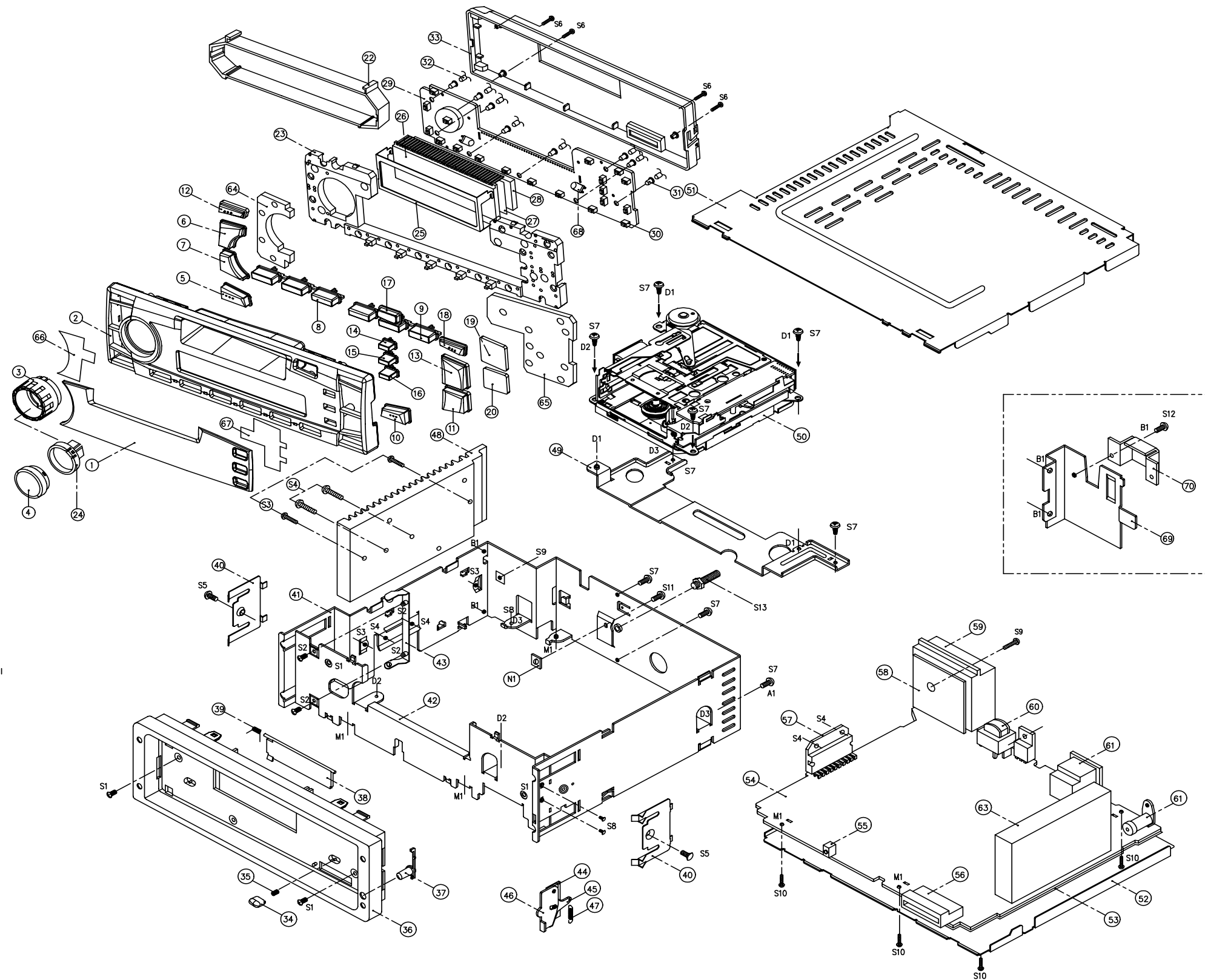

N1	7372300211	NUT SQUARE	1	4N-2-3 MFZN	
S13	97T3104900	BOLT HEX	1	SM20C M5X(3+2+10) MFZN	
S12	7173300611	SCREW TAPTITE	1	TT2 BIN 3x6 MFZN BK	OPTION
S11	7003300811	SCREW MACHINE	1	BIN 3x8 MFZN	
S10	97T3103610	SCREW LOCK	4	TT2 BIN 3x6 MFZN W/LOCK	
S9	7173301211	SCREW TAPTITE	1	TT2 BIN 3x12 MFZN	
S8	7173200612	SCREW TAPTITE	2	TT2 BIN 2X6 MFZN BK	
S7	7173300611	SCREW TAPTITE	7	TT2 BIN 3x6 MFZN BK	
S6	7173201212	SCREW TAPTITE	4	TT2 BIN 2x12 MFZN BK	
S5	7175300611	SCREW TAPTITE	2	TT2 FLT 3x6 MFZN	
S4	7173301211	SCREW TAPTITE	2	TT2 BIN 3x12 MFZN	
S3	7173301011	SCREW TAPTITE	2	TT2 BIN 3x10 MFZN	
S2	7001260411	SCREW MACHINE	2	PAN 2.6x4 MFZN	
S1	7173260612	SCREW TAPTITE	2	TT2 BIN 2.6x6 MFZN BK	
70	97T2430530	BRKT CONN	1	SECC T=1.0	OPTION
69	97T2441700	BRKT CONN	1	SECC T=1.0	OPTION
68	DDB3803X--	LED	2	DDB380X(BLUE)	
67	97T9609800	SHEET WINDOW B	1	DOUBLE TAPE T=0.16	
66	97T9609700	SHEET WINDOW A	1	DOUBLE TAPE T=0.16	
65	97T4227700	CUSHION -L	1	SPONGE T=3.0	
64	97T4227600	CUSHION VOL	1	SPONGE T=3.0	
63	97T7607401	TUNER FM/MW/LW	1	CAT-3(HES-310) WO/COVER	
62	97T6363000	JACK ANTENNA	1	PCB TYPE	
61	97T6304000	SOCKET DIN	1	PCB TYPE 8PIN DIN	
60	5LC301PA18	COIL CHOCK	1	37x15.2 300uh p ei-19mm	
59	97T8839200	CONN AS	1	ISO 26P WITH 10A FUSE	
58	97T6589500	PCB ISO	1	40x38xT1.6	
57	IHA13158A-	IC AUDIO POWER	1	HA13158A	
56	97T621250A0	CONN DETECHABLE	1	FP-S-12-3.2-GG	
55	DLT6311S4-	LED	1	L76331-54 RED WITH HOLDER	
54	97T65592MA	PCB MAIN	1	330x190/2 T=1.6	
53	97T0926200	PLATE INSULATION	1	PE T0.25	
52	97T0432900	COVER BOTTOM	1	SECC T=0.6	
51	97T0432800	COVER TOP	1	SECC T=0.6	
50	97T6008200	DECK MECHANISM	1	ADM-22	
49	97T2440500	BRKT DECK	1	SECC T=1.0	
48	97T4407700	HEAT SINK	1	AL-6063 ANODIZING	BLACK
47	97T3013300	SPRING HOOK	1	STS-304	
46	97T2608300	HOOK LEVER-C	1	PC(LEXAN-121)	GRAY
45	97T2608200	HOOK LEVER-B	1	PC(LEXAN-121)	GRAY
44	97T2608100	HOOK LEVER-A	1	PC(LEXAN-121)	GRAY
43	97T2606010	HOOK-B	1	STSP T=0.4	
42	97T0627700	CHASSIS FRONT	1	SECC T=1.0	
41	97T0627600	CHASSIS MAIN	1	SECC T=1.0	
40	97T3010400	SPRING RETAIN	2	STS-304 T=0.4	
39	97T3005610	SPRING DOOR	1	STS-304W PI 2.4x0.25x7	
38	97T1805100	CASSETTE DOOR	1	PC(LEXAN-121)	
37	97T13A6500	KNOB RELEASE	1	ABS(XR-404)	
36	97T1413200	ESCUTCHEON	1	ABS(XR-404)	
35	97T3012100	SPRING PULL	1	SUS-304 PI 0.35	
34	97T1393010	KNOB PULL	1	ABS(XR-404)	
33	97T0111300	CABINET BACK	1	PC(LEXAN-121)	
32	97T82L0DE4	LAMP PILOT	8	8V 40MA	ONE Co.
31	97T0420530	CAP LAMP	8	SILICON RUBBER	ONE Co.
30	5550101202	SW TACT	19	IC-IP SK0C10918A 260g	
29	97T65987FR	FRONT PCB	1	FR-4	
28	97T2226400	REF LCD	1	ACRYL(H-830H)	
27	97T9609600	SHEET LCD	1	TREPAL	
26	97T0L1610P	LCD	1	IS-09053P	
25	97T0439000	COVER LCD	1	ET T=0.3	
24	97T0439500	V.R KNOB SHAFT	1	PC(LEXAN-121)	
23	97T2226300	REF SW	1	ACRYL(H-830H)	
22	97T2308200	HOLDER LCD	1	PC(LEXAN-121)	
21	-	-	-	-	
20	97T0439800	CAP KNOB AUT	1	PC(LEXAN-121)	
19	97T0439700	CAP KNOB TAPE	1	PC(LEXAN-121)	
18	97T13E0100	KNOB CDC	1	PC(LEXAN-121)	Laser Cut
17	97T13E0000	KNOB EJECT	1	PC(LEXAN-121)	Laser Cut
16	97T13E1900	KNOB PTY	1	PC(LEXAN-121)	Laser Cut
15	97T13E1800	KNOB TA	1	PC(LEXAN-121)	Laser Cut
14	97T13E0500	KNOB AF	1	PC(LEXAN-121)	Laser Cut
13	97T13E0200	KNOB TAPE	1	ACRYL(H-830H)	
12	97T13D9500	KNOB BAND	1	PC(LEXAN-121)	Laser Cut
11	97T13E0300	KNOB AUT	1	ACRYL(H-830H)	
10	97T13E0400	KNOB LOUD	1	PC(LEXAN-121)	Laser Cut
9	97T13E1700	KNOB PRESET-R	1	PC(LEXAN-121)	Laser Cut
8	97T13D9900	KNOB PRESET-L	1	PC(LEXAN-121)	Laser Cut
7	97T13D9700	KNOB TUNING DN	1	PC(LEXAN-121)	Laser Cut
6	97T13D9600	KNOB TUNING UP	1	PC(LEXAN-121)	Laser Cut
5	97T13D9800	KNOB SEL	1	PC(LEXAN-121)	Laser Cut
4	97T13D9000	KNOB POWER LENZ	1	ACRYL(H-830H)	
3	97T13D9400	KNOB VOLUME	1	ABS(XR-404)	
2	97T0111200	CABINET FRONT	1	ABS(XR-404)	Slk Screen
1	97T1609700	WINDOW LCD	1	ACRYL(H-830H)	Slk Screen

7. DECK MECHANISM EXPLODED VIEW&PARTS LIST

7-1. ADM-21/22 EXPLODED VIEW

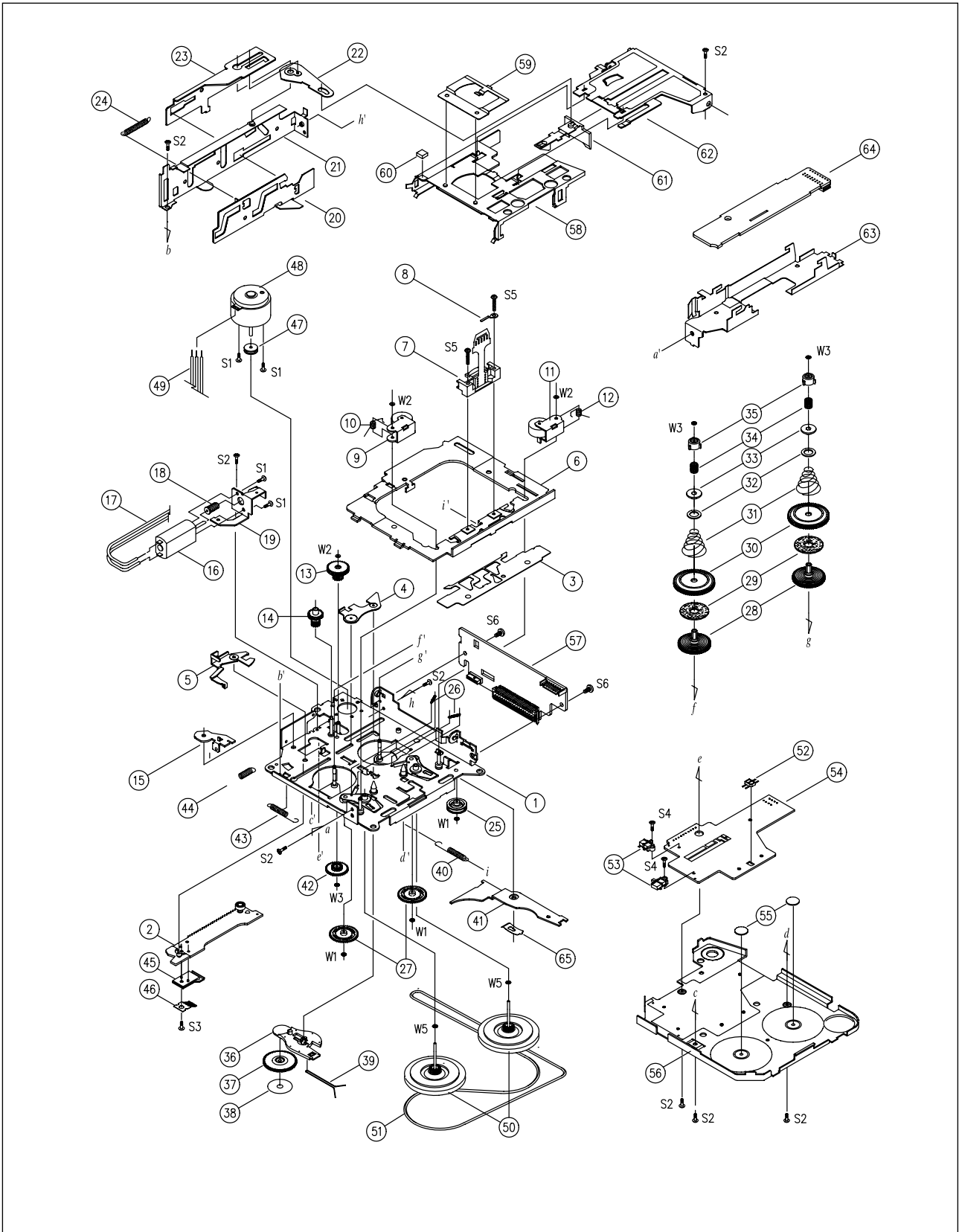

DECK MECHANISM EXPLODED VIEW & PARTS LIST
for AKL-3010 Series & AKL-0106Series

7-2. PARTS LIST for ADM-21/22

No	PART CODE	PART NAME	DESCRIPTION
1	97YM002600	CHASSIS MAIN SUB AS	ADM-22 FULL LOGIC DECK
2	97YM002900	LEVER GEAR LOAD AS	ADM-22 FULL LOGIC DECK
3	97Y0900800	PLATE REVERSE	SUS-304 1/2H T0.4
4	97Y2100400	ARM EJ CAM	EGSAFC45R T0.8
5	97Y2101000	ARM TAPE SELECT	EGSAFC45R T0.8
6	97Y0900200	PLATE HEAD	EGSAFC45R T0.8
7	97Y8000300	HEAD AS	HEAD+FPC
8	97Y6400100	TERMINAL EARTH	ET T0.2
9	97YM003200	ARM PINCH R AS	ADM-22 FULL LOGIC DECK
10	97Y3000400	SPRING PINCH ARM (R)	SWP-B PI0.65 TORS
11	97YM003100	ARM PINCH F AS	ADM-22 FULL LOGIC DECK
12	97Y3000300	SPRING PINCH ARM (F)	SWP-B PI0.65 TORS
13	97Y2700400	GEAR REDUCTION	POM DURACON M90-44 (N)
14	97Y2700800	GEAR WORM WHEEL	POM DURACON OL-10 (N)
15	97Y2100500	ARM IN SW	EGSAFC45R T0.8
16	97Y8100200	MOTOR SUB	FF-050SH-11190
17	WP-7021563	WIRE RIBBON	AWG28 2P
18	97Y2700700	GEAR WORM	POM DURACON M90-44 (N)
19	97Y2400200	BRACKET MOTOR	EGSAFC45R T0.8
20	97Y2700900	CAM EJECT	EGSAFC45R T0.8
21	97YM003400	BRACKET L AS	ADM-22 FULL LOGIC DECK
22	97YM003500	ARM TAPE CATCH A AS	ADM-22 FULL LOGIC DECK
23	97Y2101400	ARM TAPE CATCH (B)	EGSAFC45R T0.8
24	97Y3000800	SPRING TAPE CATCH ARM	SWP-B PI0.65 EXTN
25	97Y3700100	PULLEY IDLE	POM DURACON ES-5
26	97Y3000900	SPRING TU ARM	SUS-403WPB PI0.2 EXTN
27	97Y2700600	GEAR TU	POM DURACON OL-10 (N)
28	97Y2900200	REEL SPINDLE	POM DELRIN-500 (N)
29	97Y4100100	FELT REEL	FELT PI5.6XPI18XT0.8
30	97Y2700500	GEAR REEL	POM DELRIN-500 (N)
31	97Y3000600	SPRING REEL	SUS-304WPB PI0.7 CONE
32	97Y3100100	WASHER REEL	PS PI4.0XPI18.0XT0.4
33	97Y4000100	BUSHING REEL	POM DURACON M90-44 (N)
34	97Y3000500	SPRING REEL CAP	SUS-304WPB PI0.3 COMP
35	97Y0400100	CAP REEL	POM DURACON M90-44 (N)
36	97Y2101500	ARM DETECT GEAR	POM DURACON M90-44 (N)
37	97Y2701200	GEAR DETECT	POM DURACON M90-44 (BK)

DECK MECHANISM EXPLODED VIEW & PARTS LIST
for AKL-3010 Series & AKL-0106Series

No	PART CODE	PART NAME	DESCRIPTION
38	97Y9300200	LABEL REFLECTION	ALS T0.05 PI15.8
39	97Y3001100	SPRING DETECT ARM	SWP-B PI0.4
40	97Y3001200	SPRING HEAD PLATE	AWP-B PI0.4 EXTN
41	97Y0900400	PLATE REVERSE B	EGSAFC45R T0.8
42	97Y2700100	GEAR POWER	SMF5030
43	97Y3001300	SPRING SELECT ARM	SUS-304WPB PI0.25 EXTN
44	97Y3001000	SPRING IN SW ARM	SUS-304WPB PI0.25 EXTN
45	97Y0400200	COVER BRUSH	POM DURACON M90-44 (BK)
46	97Y3300100	BRUSH CONTROL	GNP T0.1
47	97Y3700700	PULLEY MOTOR	MBSBM
48	97Y8100300	MOTOR MAIN	MC15U3LDCN
49	WP-7030803	WIRE RIBBON	AWG28 3P
50	97Y2900400	FLYWHEEL AS	ZDC2/C2700/SUS-420J2
51	97Y5500200	BELT MAIN	EPDM PI120.3XT1
52	1SPI31525-	IC PHOTO REFLECTOR	SPI-315-25
53	5S40101A19	SW PUSH	SW-110 1C-1P NORMAL OPEN
54	97Y6500700	PCB REFLECTOR A	XPC 78X57XT0.8
55	97Y3900100	POLYSLIDER FLYWHEEL	PS PI8.0XT0.3
56	97Y0900100	PLATE BOTTOM	EGSAFC45R T0.6
57	97YC000500	PCB CONNECTION AS	ADM-22 FULL LOGIC DECK
58	97Y2300100	HOLDER CASSETTE	EGSAFC45R T0.8
59	97Y0900700	PLATE SPG CASS HOLD	SUS-304WPB T0.2
60	97Y4200100	CUSHION HOLDER	EVA 6.5X6.5XT1.0
61	97Y2600100	HOOK TAPE	POM DURACON M90-44 (N)
62	97Y2101300	HANGER CASSETTE	EGSAFC45R T0.8
63	97Y2400300	BRACKET PCB	SECC-E T0.8
64	97YC000600	PCB EQ AS	ADM-22 FULL LOGIC DECK
65	97Y5700100	STOPPER REV PLT B	SUS-304 T0.2
S1	7003200211	SCREW MACHINE	BIN M2X2.5 MFZN
S2	7273200311	SCREW TAPTITE	TT3 BIN 2X3 MFZN
S3	7273200411	SCREW TAPTITE	TT3 BIN 2X3.5 MFZN
S4	7273170511	SCREW TAPTITE	TT3 BIN 1.7X5 MFZN
S5	7273201011	SCREW TAPTITE	TT3 BIN 2X10 MFZN
S6	7173260611	SCREW TAPTITE	TT2 BIN 2.6X6 MFZN
W1	97Y3900200	POLYSLIDER WASHER	PS PI1.2XPI3.2XT0.25
W2	97Y3900300	POLYSLIDER WASHER	PS PI1.5XPI3.2XT0.25
W3	97Y3900600	POLYSLIDER WASHER	PS PI1.5XPI3.2XT0.4
W4	97Y3900500	POLYSLIDER WASHER	PS PI2XPI4XT0.4
W5	97Y3900700	POLYSLIDER WASHER	PS PI1.9XPI3.2XT0.25

8. PARTS LIST

for AKL-3010Series & AKL-0106Series

CAUTION **R** is a recommendable part for essential stock.

8-1. MAIN SECTION

LOCATION	CODE	NAME	DESCRIPTION
IC101	1SAA6579T-	IC AUDIO	SAA6579T (RDS Demodulator)
IC201	1BA3121---	IC ISOLATION	BA 3121
IC301	1DBL2084N-	IC MOTER DRIVER	LB1641 or DBL2084N
IC303	1LC75372E-	IC CHIP EVR	LC75372E
IC304	1TDA8571J-	IC POWER	IC POWER TDA8571J
IC401	176S8016X2	IC MICOM	IC MICOM UPD178016GC-
IC402	1KIA7808P-	IC REGULATOR	IC REGULATOR KIA7808P
J101	97T6366900	JACK ANT	JACK ANT ANT J-020-03
LD01	DLT6339S4-	LED	LT6339-S4 RED
L301	5LC301PA18	COIL CHOCK	37X1X5.2 300UH P EI-19MM
RV108	RV1417504-	R SEMI FIXED	H500K-5X5-6N-PC-BS
TU101	CAT-7-NC	TUNER	FM/MW/LW
	CAT-6-NC	TUNER	FM/MW
	CAT-8-NC	TUNER	FM/OIRT/MW
	CET 6056ASF	TUNER	FM/MW/SW1/SW2
DZ103, DZ401	DKTZJ5R1A-	DIODE ZENER	5.1V
DZ351, 402	DKTZJ5R6B-	DIODE ZENER	5.6V
DZ403	DKTZJ6R2B-	DIODE ZENER	6.2V
DZ301	DKTZJ6R8B-	DIODE ZENER	6.8V
DZ302.303	DKTZJ9R1B-	DIODE ZENER	9.1V
DZ101	DKTZJ100B-	DIODE ZENER	10V
CT130	5XEZ4R332D	CRYSTAL QUARTZ	HC-49/U 4.332MHz 20PF
CT401	5XEZ4R500E	CRYSTAL QUARTZ	HC-49/U 4.5MHz 12PF
Q401	TZTC3198Y-	TR	KTC3198 Y
Q406	TZTA1273Y-	TR	KTA1273Y
Q106, 107	TZTC3113B-	TR	KTC 3113B
Q303	TZ2SB1240R	TR	2SB1240R
Q101,201,302,Q304, 407	TZRC102M--	TR	KRC102M
Q102, 104	TZRA105M--	TR	KRA-105M
Q103, 307	TZRC102M--	TR	KRC102M
Q108	TZTC3205Y-	TR	KTC3205Y
Q202, 306	TZTA1267Y-	TR	KTA1267Y
Q301	TZRA101M--	TR	KRC101M
Q305	TZTC3199Y-	TR	KTC3199Y
Q309,310,351,Q352,353	TZDTC323TS	TR	DTC323TSA
CN305	97T6304000	CONNECTOR	PCB TYPE 8PIN DIN

PARTS LIST for AKL-3010Series & AKL-0106Series

LOCATION	CODE	NAME	DESCRIPTION
CW301	97T6215902	CONN WAFER	5076-118-2.5MM
C372	CEYE1C332E	CONDENSER ELEC.	16V 3300MF
DT01	97T62150A0	CONN DETACHABLE	FP.S-12-3.2-GG

8-2. FRONT SECTION

LOCATION	CODE	NAME	DESCRIPTION
CW701	97T6217100	CONNECTOR	FPP-1434-GG 5mm
LCD	97T0L1610P	L.C.D	1S-09053P
LED01 - 02	DDB3803X--	LED	DB3803X(BLUE)
PL01- 08	97T82L0W84	PILOT LAMP	8V 40MA
VR01	5V3503A70A	VE ENCODER	SRGP 200 200
SW01	5S50101Z02	SW TACK	1C-1P SKQC 10918B 260G
SW02	5S52643CL1	SW TACK	1C-1P SKMA 10918A 260G CHIP TYPE
IC701	1HL14104--	LCD DRIVER IC	HL14104

8-3. FM ONE CHIP SECTION

LOCATION	CODE	NAME	DESCRIPTION
Ⓜ L02	5LA109KA22	COIL ANT	0.5X3.4X3.5+3.0 R/NA
Ⓜ L06	5LL100K02K	COIL INDUCTOR	10UH K 02 TA 26MM
Ⓜ L08	5LL109K02K	COIL INDUCTOR	1UH K 02 TA 26MM
Ⓜ L01	5LL479K02K	COIL INDUCTOR	4.7UH K 02 TA 26MM
Ⓜ L04	5L0109KA23	COIL OSC	0.5X3.0X2.5+3.0 R/NA
Ⓜ L07	5LT109KA21	COIL TRAP	0.3X1.8X7 1/2 L/NA
D01, D20, D81, D82	DKSS133---	DIODE	1SS133 AUTO 26MM
D02, D03	DKDS266--B	DIODE CHIP	KDS266 SOT-23 C3
D12	D1SV234--A	DIODE CHIP	1SV234
DA04	DKB0714-3-	DIODE VARICAP	AM KV0714-3
D09, D10, D11	DKV1440TLB	DIODE VARICAP	FM KV1440TLB
Q01	TFC12-----	FET	AM FC-12
Q05	T3SK231U1D	FET	FET 3SK231UID
FC04	5PCFM450AL	FILTER CERA	AHCFM2 - 450AL
FC02, FC03	5PE107MJA1	FILTER CERA	SFE10.7MJA10 RED
FC01	5PE107M3A1	FILTER CERA	SFE10.7KS3A10
CR01	5PB456A12-	FILTER MECHA	CMU2-456A12
IC01	1DBL1091--	IC	DBL1091
IC03	1LA1177---	IC RF	LA1177 FM SIP TYPE
AIF	5105AYWA35	IFT AM	5DL-C5167
FDET	5107FBKA30	IFT FM DET	7BS-C4024
FIF	5105F0RA29	IFT FM IF	5DLH-C5115
FRF	5107FBKA31	IFT FM RF	7BSF-N1025
ARF11	5105AGYA36	IFT LW RF1	5DLP-N5162
ARF21	5105ABLA37	IFT LW RF2	5DLP-N5163
ARF01	5105AWHA32	IFT MW RF1	5DL-N5165
ARF02	5105AGNA33	IFT MW RF2	5DL-N5166
LOSC	5105ABRA38	IFT OSC	5DL-N5164
AOSC	5105ARDA34	IFT OSC	5DL-N5146
RV01	RV4417103-	R SEMI FIXED	H10K - 5X5 - 6N - CC - BS
Q81	TKRC110S-B	TR CHIP	KRC110S SOT - 23
Q02	TKRC110S-B	TR CHIP	KRC111S
Q03, Q11	TKRC112S--	TR CHIP	KRC - 112S
Q04, Q12, Q13, Q82, Q83, Q84	TKTC3875GB	TR CHIP	KTC3875 - GR
Q10	TKTC3879-B	TR CHIP	KTC3879

9. FUNCTION OF MICOMIC

9-1. PIN CONFIGURATION (TOP VIEW)

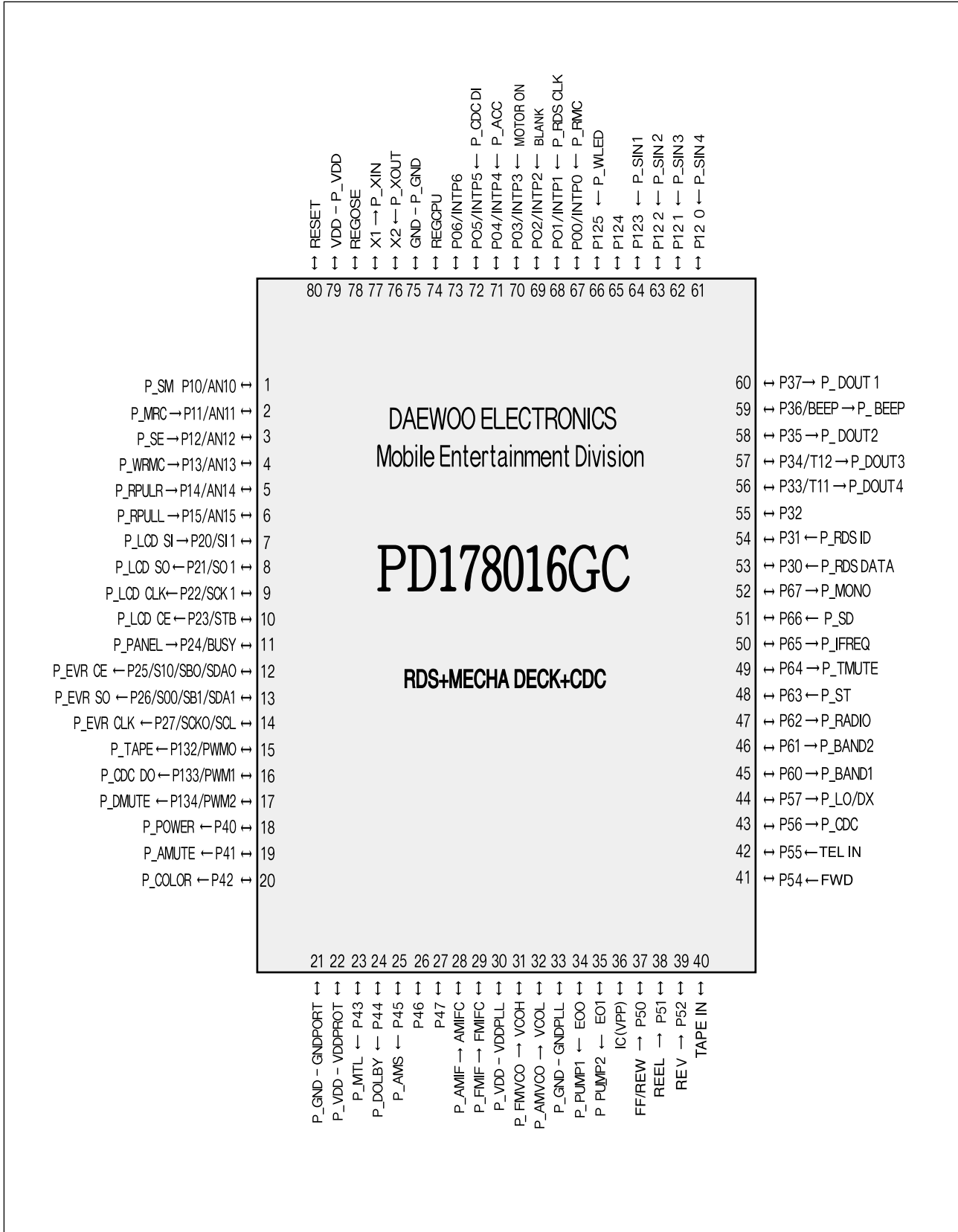

9-2. PIN DESCRIPTION

PIN	ASSIGN	NAME	DESCRIPTION	I/O
77	P_XIN	X1	4.5 MHz CRYSTAL	I
76	P_XOUT	X2		O
22	P_VDD	VDDPORT	PERMANENT POWER INPUT PORT)MAX : 6.5V GROUND	
30	P_VDD	VDDPLL		
79	P_VDD	VDD		
22	P_GND	GNDPORT		
33	P_GND	GNDPLL		
75	P_GND	GND		
71	P_ACC	P04/INTP4	BACK UP MODE CONTROL PORT. LOW : BACK UP MODE. HIGH : OPERATING MODE.	I
18	P_POWER	P40	POWER CONTROL PORT. POWER OFF → LOW, POWER ON → HIGH	O
7	P_LCD SI	P20/SI1	KEY & LCD DRIVER IC INTERFACE PORTS.	I
8	P_LCD SO	P21/SO1		O
9	P_LCD CLK	P22/SCK1		O
10	P_LCD CE	P23/STB		O
12	P_EVR CE	P25/SI0	EVR IC INTERFACE PORTS	O
13	P_EVR SO	P26/SO0		O
14	P_EVR CLK	P27/SCK0		O
19	P_AMUTE	P41	AUDIO MUTE PORT, ACTIVE HIGH	O
59	P_BEEP	P36/BEEP	BEEP OUTPUT PORT. (2.08 KHz)	O
4	P_WRMC	P00/INTP0	WIRE REMOCON INPUT PORT.	I
67	P_RMC	P24/BUSY	WIRELESS REMOCON INPUT PORT.	I
11	P_PANEL	P42	DETACHABLE ON / OFF INPUT PORT. CONTACT → LOW SEPARATE → HIGH	I
20	P_COLOR		LCD BACK - LIGHTING COLOR CONTROL PORT RESET : COLOR → "LOW" TWO KEY IN : CHANGED	O

**FUNCTION OF MICOMIC UPD178016GC
for AKL-3010 Series & AKL-0106Series**

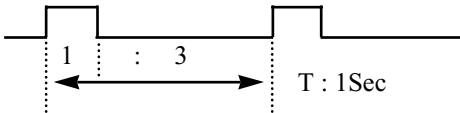
PIN	ASSIGN	NAME	DESCRIPTION	I/O															
66	P_WLED	P125	WARNING LED OUTPUT PORT. * OUT PUT CONDITION : PANEL OFF 	O															
42	P_PHONE	P55	TELEPHONE MUTE (ACTIVE LOW)	I															
3	P-SE	P12/AN12	SE KEY INPUT PORT (ACTIVE LOW)	I															
64	P-SIN1	P123	OPTION DIODE MATRIX INPUT PORT.	I															
63	P-SIN2	P122		I															
62	P-SIN3	P121		I															
61	P-SIN4	P120		I															
60	P_DOUT1	P37	OPTION DIODE MATRIX OUTPUT PORT.	O															
58	P_DOUT2	P35		O															
57	P_DOUT3	P34/T12		O															
56	P_DOUT4	P33/T11		O															
47	P_RADIO	P62	RADIO MODE CONTROL PORT	O															
45	P_BAND1	P60	BAND SELECT PORT (TUNER MODE)	O															
46	P_BAND2	P61		<table border="0"> <tr> <td></td> <td>RESET</td> <td>FM</td> <td>MW</td> <td>LW</td> </tr> <tr> <td>BAND1 :</td> <td>0</td> <td>1</td> <td>0</td> <td>0</td> </tr> <tr> <td>BAND2 :</td> <td>0</td> <td>0</td> <td>1</td> <td>0</td> </tr> </table>		RESET	FM	MW	LW	BAND1 :	0	1	0	0	BAND2 :	0	0	1	0
	RESET	FM	MW	LW															
BAND1 :	0	1	0	0															
BAND2 :	0	0	1	0															
49	P_TMUTE	P64	MUTE OUTPUT AT AF CHECKING (ACTIVE HIGH)	O															
48	P_ST	P63	STEREO INPUT PORT. (ACTIVE LOW)	I															
51	P_SD	P66	SIGNAL DETECTION PORT. (ACTIVE HIGH)	I															
1	P_SM	P10/AN10	SIGNAL METER INPUT PORT. * RANGE : SEEK : LOCAL : SD ACTIVE CHECK DX : SD ACTIVE CHECK AF --> AF CHECK STOP VOLTAGE 2.2 V	I															

FUNCTION OF MICOMIC UPD178016GC
for AKL-3010 Series & AKL-0106Series

PIN	ASSIGN	NAME	DESCRIPTION	I/O
31	P_FMVCO	VCOH	FM VCO INPUT PORT. INPUT RANGE : 0.07 ~ 1.5 Vrms	I
32	P_AMVCO	VCOL	AM VCO INPUT PORT. INPUT RANGE : 0.07 ~ 1.5 Vrms	I
29	P_FMIF	FMIFC	FM IF COUNT INPUT PORT. RANGE:10.7 MHz \pm 30KHz ,Vpp = 0.07~1.5 Vrms	I
28	P_AMIF	AMIFC	AM IF COUNT INPUT PORT. INPUT RANGE : 450 KHz \pm 1KHz (AM) 450 KHz \pm 0.37 KHz (LM) Vpp = 0.07 ~ 1.5 Vrms	I
50	P_IFREQ	P65	IF REQUEST PORT. * TUNING : HIGH OUTPUT	O
44	P_LO/DX	P57	LOCAL MODE \rightarrow HIGH <input type="checkbox"/> DX MODE \rightarrow LOW	O
52	P_MONO	P67	(RADIO MODE) MONO MODE \rightarrow HIGH STREO MODE \rightarrow LOW	O
34	P_PUMP1	E00	PLL ERROR OUT1 PORT.	O
35	P_PUMP2	E01	PLL ERROR OUT2 PORT.	O
53	P_RDS DATA	P30	RDS DATA INPUT PORT.	I
54	P_RDS ID	P31		I
68	P_RDS CLK	P01/INTP1		I
2	P_MRC	P11/ANI1	MULTI-PATH INPUT PORT. * MULTI-PATH : 0.6 ~ 0.9 V	I
43	P_CDC	P56	CDC MODE ON OUTPUT PORT. ACTIVE HIGH	O
72	P_CDC DI	P05/INTP5	CDC DATA COMMUNICATION PORT.	I
16	P_CDC DO	P133/PWM1		O

FUNCTION OF MICOMIC UPD178016GC
for AKL-3010 Series & AKL-0106Series

PIN	ASSIGN	NAME	DESCRIPTION	I/O
15	P_TAPE	P132/PWM0	TAPE MODE OUTPUT PORT.	O
40	P_TAPE IN	P50	TAPE CASSETTE CONDITION CHECK PORT * LOW : EJECT CONDITION * HIGH : LOADING CONDITION	I
37	P_FWD IN	P52	TAPE FWD/RVS PLAY CONDITION INPUT PORT * RVS : HIGH FWD : LOW	I
38	P_FF IN	P51	TAPE PLAY/FF CONDITION INPUT PORT * PLAY : LOW FF : HIGH	I
25		P45		O
24	P_DOLBY	P44	DOLBY MODE (ACTIVE HIGH)	O
23	P_MTL	P43	METAL ON : HIGH, METAL OFF : LOW OUTPUT.	O
17	P_DMUTE	P134/PWM2	DECK MUTE PORT	O

MATRIX TABLE OF KEY & OPT. DIODE
for AKL-3010 Series & AKL-0106Series

● **KEY MATRIX TABLE :**

Return Source	KI 1 (50)	KI 2 (51)	KI 3 (52)	KI 4 (53)	KI 5 (54)
KS 6 (49)	T.UP	T.DOWN	-	LOC/LOUD (B:LOC)	-
KS 5 (48)	M1 (TOP)	M2 (DOLBY)	M3 (METAL) (REPEAT)	TA/TA_STBY (B:SCAN UP)	AF/REG (B:LOUD)
KS 4 (47)	M4 (SHUFFLE)	M5 (DISC DOWN)	M6 (DISC UP)	DISP/PTY (B:DISP)	ATP (INTRO)
KS 3 (46)	Audio UP	Audio DOWN	Audio MODE	POWER	-
KS 2 (45)	-	-	CDC PLAY/PAUSE	BAND/ LANG	MUTE
KS 1 (44)	-	-	-	-	-

● **OPTION DIODE TABLE (MAIN PCB BOARD)**

SOURCE RETURN	P_DOUT 1 (P37, 60PIN)	P_DOUT 2 (P35, 60PIN)	P_DOUT 3 (P34, 57PIN)	P_DOUT 4 (P33, 56PIN)
P_SIN 1 (P123, 64PIN)	-	-	-	-
P_SIN 2 (P122, 63PIN)	FM_ONLY (D403)	EN_RDS (D407)	LW_ENABLE (D411)	-
P_SIN 3 (P121, 62PIN)	DIS_CLOCK (D402)	TUNER 1, 2 (D406)	DIS_FAD (D410)	-
P_SIN 4 (P120, 61PIN)	AREA 1 (D401)	AREA 2 (D405)	AREA 3 (D409)	-

10. IC BLOCK DIAGRAM

10-1. LC75854 (IC LCD DRIVER) :IC701

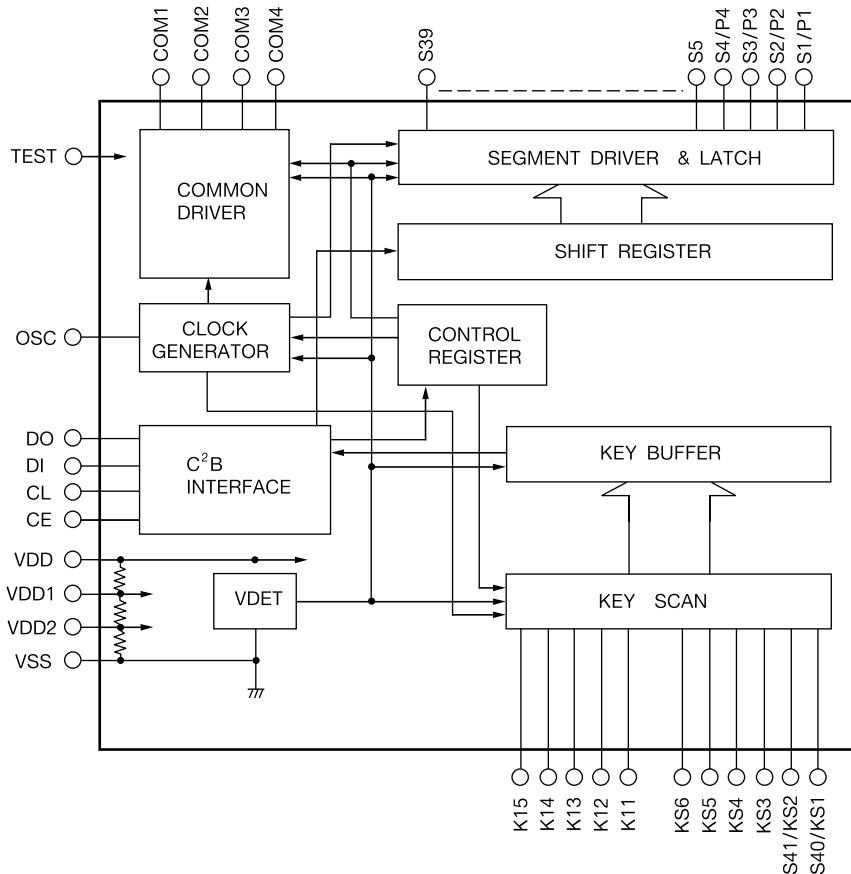
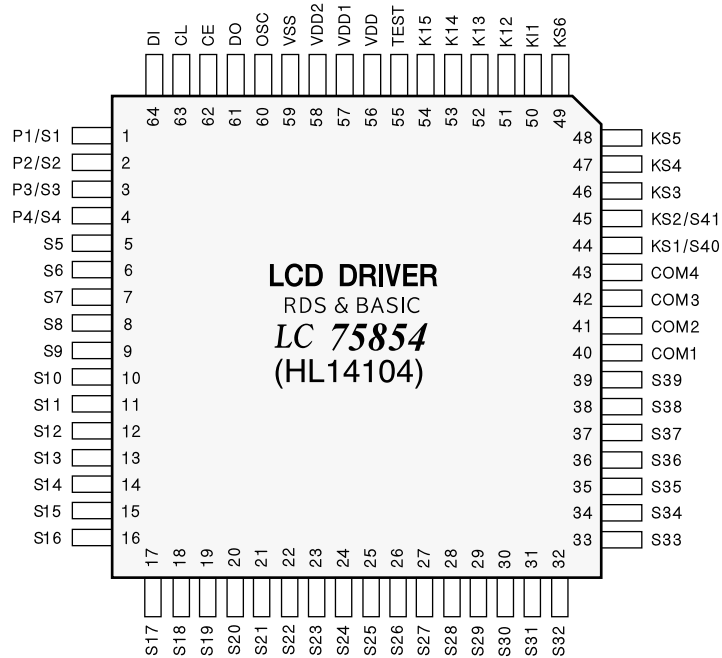

10-2. LB1641 / DBL2084N (TAPE PRE-AMP) : IC301

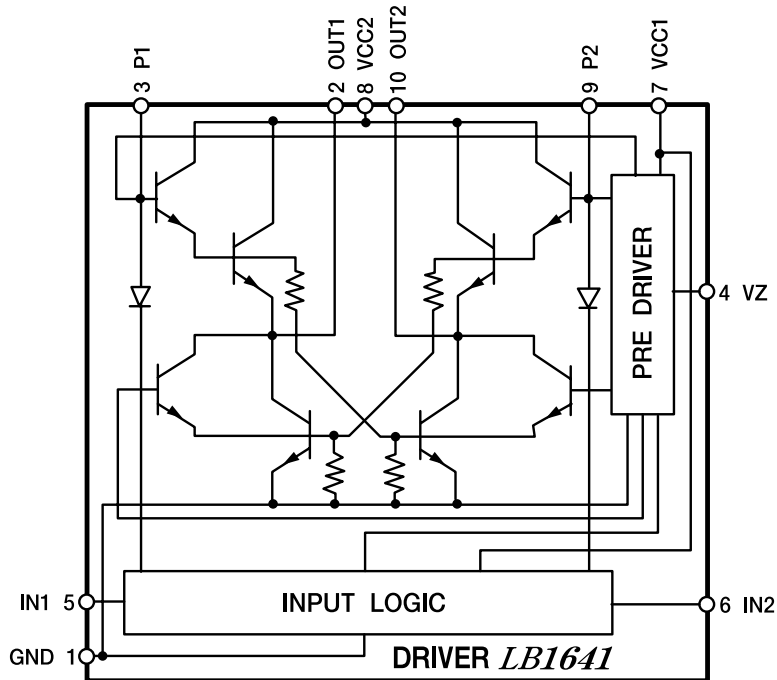

10-3. SAA6579T (IC Audio):IC101

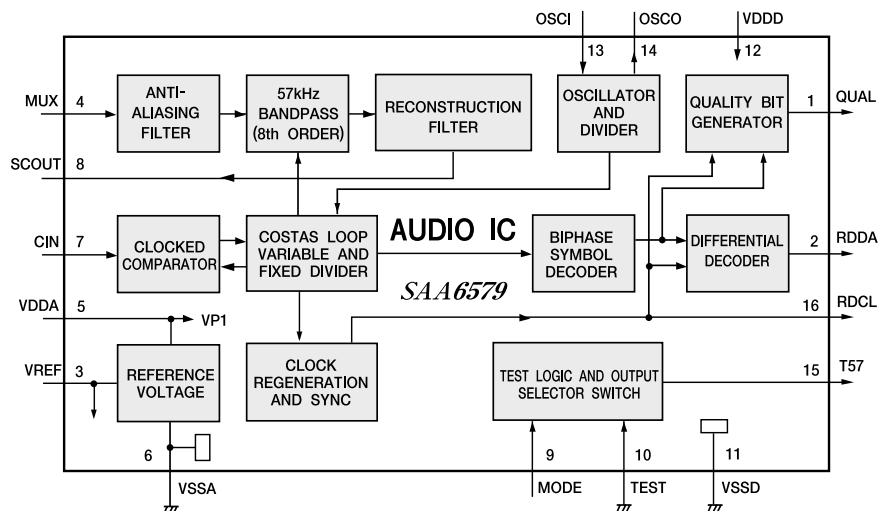
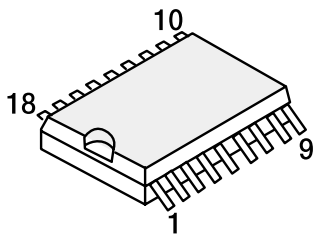

10-4. TDA8571J (IC Audio Power):IC304

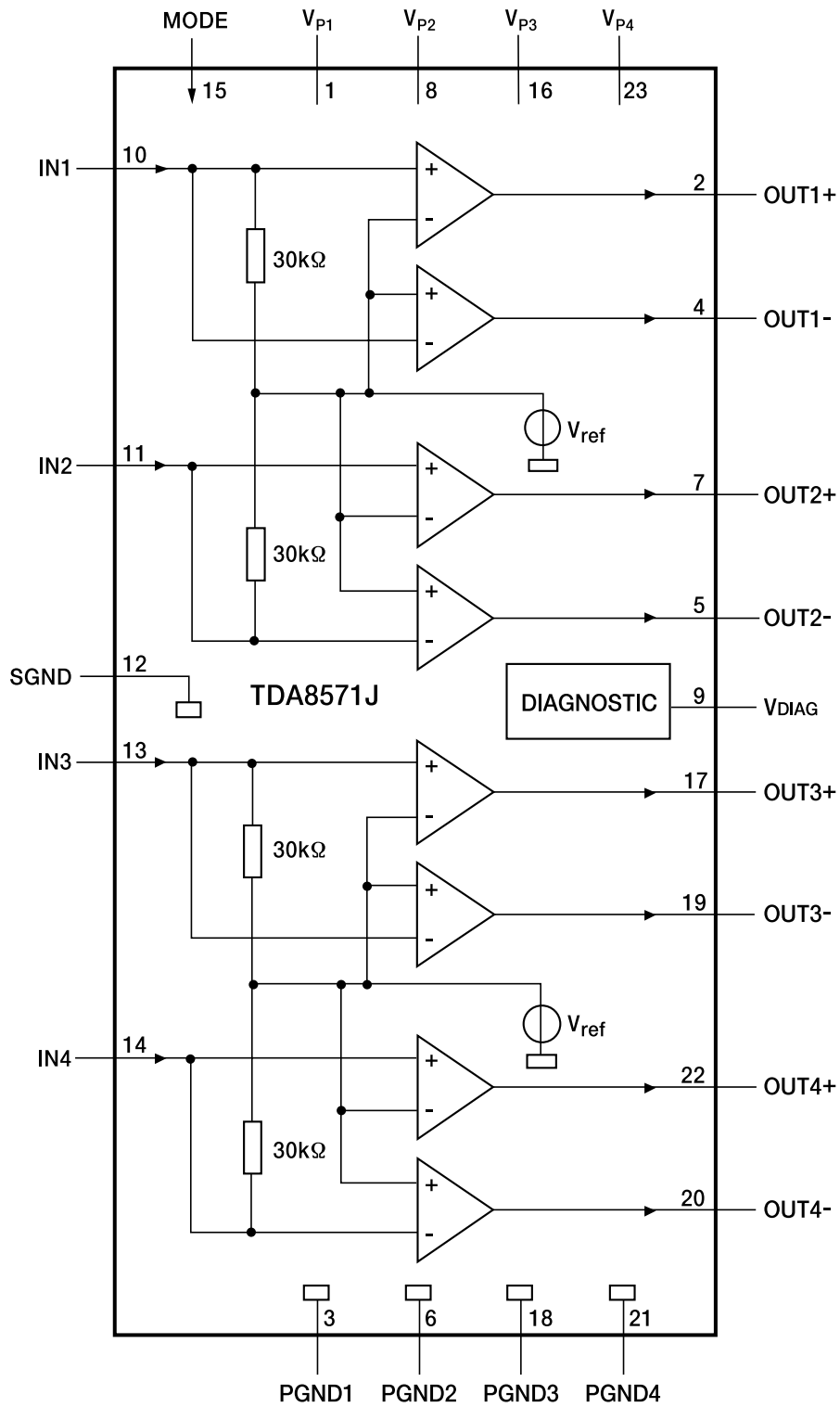

10-5. BA3121 (IC ISOLATOR):IC201

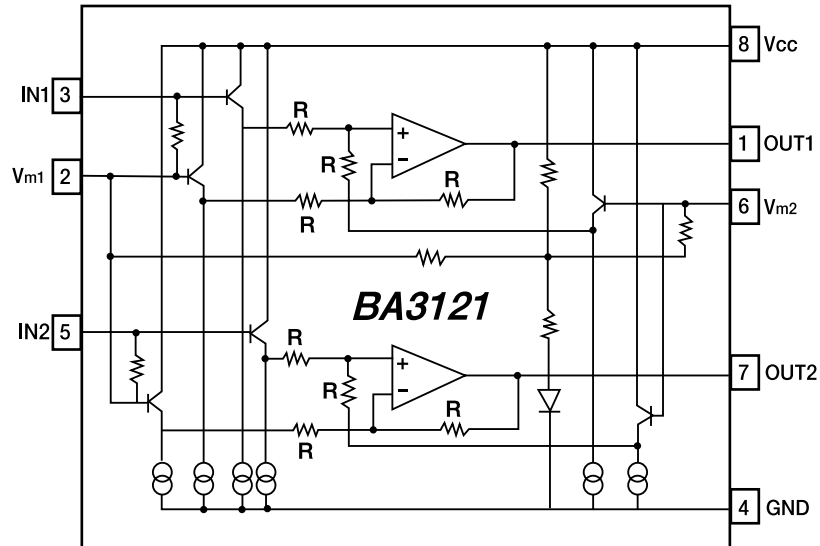

11. LIQUID CRYSTAL DISPLAY

for AKL-3010RC
& AKL-0106Series

11-1. AKL-3010RC

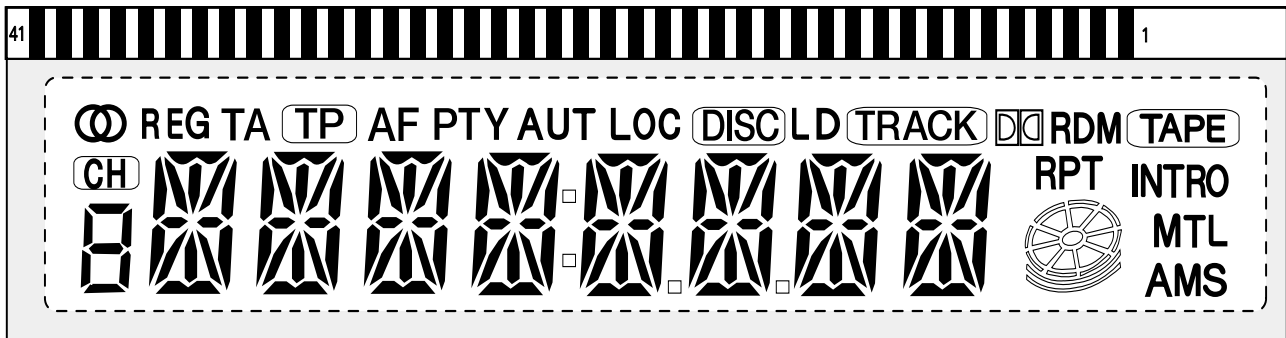

IC NO	39	38	37	36	35	34	33	31	32	6	7	8	9	10	11
LCD NO.	1	2	3	4	5	6	7	8	9	10	11	12	13	14	15
COM1	S4	S5	S1	S6	9H	9A	S3	TRACK	8H	8A	LD	COL1	7H	7A	DISC
COM2	INTRP	RPT	---	9B	9G	90	9F	8B	8G	80	8F	7B	7G	70	7F
COM3	MTL	RDM	COL2	9I	9K	9L	8N	8I	8K	8L	8N	7I	7K	7L	7N
COM4	AMS	TAPE	---	9C	9D	9M	9E	8C	8D	8M	8E	7C	7D	7M	7E

IC NO	12	13	14	15	30	29	28	27	26	25	24	23	22	21	20
LCD NO.	16	17	18	19	20	21	22	23	24	25	26	27	28	29	30
COM1	LOC	6H	6A	COL	AUT	5H	5A	S2	PTY	4H	4A	AF	TP	3H	3A
COM2	6B	6G	60	6F	5B	5G	50	5F	4B	4G	40	4F	3B	3G	30
COM3	6I	6K	6L	6N	5I	5K	5L	5N	4I	4K	4L	4N	3I	3K	3L
COM4	6C	6D	6M	6E	5C	5D	5M	5E	4C	4D	4M	4E	3C	3D	3M

IC NO	19	18	17	16	5	4	3	40	41	42	43
LCD NO.	31	32	33	34	35	36	37	38	39	40	40
COM1	TA	REG	2H	2A	S7	1A	CH	COM1	---	---	---
COM2	3F	2B	2G	20	2F	1B	1F	---	COM2	---	---
COM3	3N	2I	2K	2L	2N	1C	1G	---	---	COM3	---
COM4	3E	2C	2D	2M	2E	1D	1E	---	---	---	COM4

12. OUTPUT CONNECTOR DESCRIPTIONS

12-1. 26 Pin CONNECTOR

The pins in the ISO connector have the following functions (connector seen from the rear)

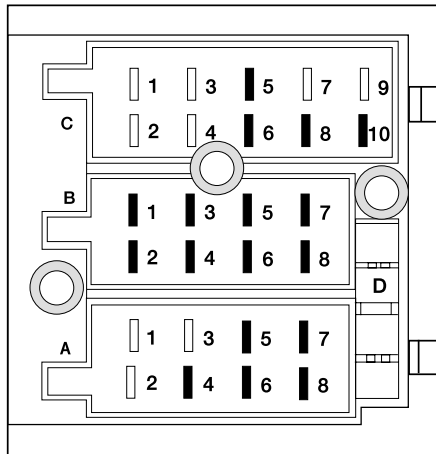

A. ELECTRIC CONNECTIONS

4. Back-up+12V : YELLOW
5. +12V (electric antenna) : BLUE
6. Dimmer : PINK
7. +12V supply(from ignition lock) : RED
8. Earth : BLACK

B. LOUD SPEAKER

1. +Right Rear : VIOLET
2. - Right Rear : VIOLET/BLACK
3. +Right Front : GRAY
4. - Right Front : GRAY/BLACK
5. +Left Front : WHITE
6. - Left Front : WHITE/BLACK
7. +Left Rear : GREEN
8. - Left Rear : GREEN/BLACK

C. OTHER (OPTION)

5. EARTH
6. TRIP LINE AMPLIFIER(ACC 12V)
8. LINE-OUT(RIGHT)
10. LINE-OUT(LEFT)

D. FUSE

10A

12-2. 8 Pin CONNECTOR

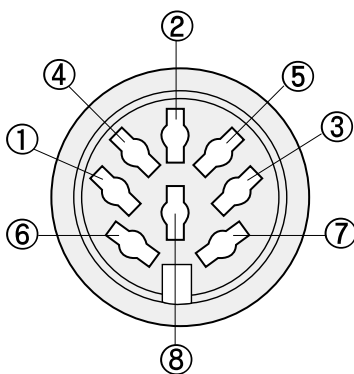

1	CDC-ON
2	BACK-UP B+
3	NO CONNECTION
4	DATA
5	GROUND
6	R-CH
7	L-CH
8	SIGNAL GROUND

12-3. 13PIN CONNECTOR

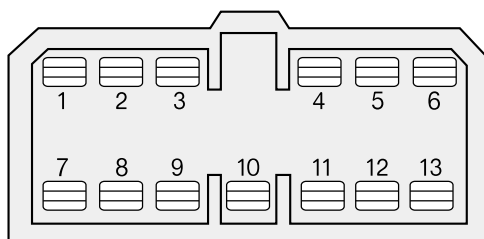

1	REAR LEFT SP(-)	8	REAR RIGHT SP(+)
2	REAR RIGHT SP(-)	9	NEGATIVE GROUND
3	AUTO ANT	10	RIGHT (ILLUMINATION)
4	ACC B(+)POWER	11	BATTERY B+(BACK-UP)
5	FRONT RIGHT SP(+)	12	FRONT RIGHT SP(-)
6	FRONT LEFT SP(+)	13	FRONT LEFT SP(-)
7	REAR LEFT SP(+)		

12-4. 18PIN CONNECTOR

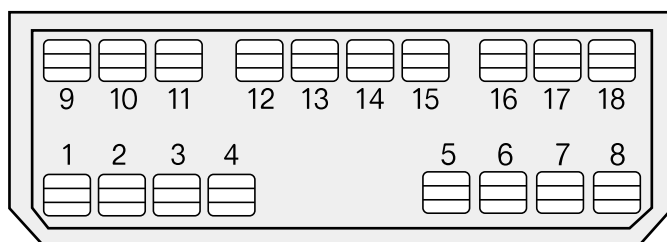

1	FRONT R-CH SP(+)	7	REAR L-CH SP(+)	13	NO CONNECTION
2	REAR R-CH SP(+)	8	FRONT L-CH SP(+)	14	GROUND
3	ILLUMINATION(+)	9	FRONT R -CH SP(-)	15	NO CONNECTION
4	ACC. B(+)	10	REAR R-CH SP(-)	16	NO CONNECTION
5	BACK UP B+	11	ILLUMINATION(-)	17	REAR L-CH SP(-)
6	NO CONNECTION	12	AUTO ANT. B+	18	FRONT L-CH SP(-)

NOTE! The red cable must be connected via the car's ignition lock to prevent unwanted discharge of the battery if it is not used for longer periods of time.

DAEWOO

DAEWOO ELECTRONICS CO., LTD

686, AHYEON-DONG MAPO-GU
SEOUL, KOREA

C.P.O. BOX 8003 SEOUL, KOREA

TELEX : DWELEC K28177-8

CABLE : "DAEWOOELEC"

E-mail : G7F00E@web.dwe.co.kr

TEL : 82-2-360-7799

FAX : 82-2-360-7877

AKR0108EFO
010301
edited by Mc. Cem