

Mat. – Nr. – Konstante
3740

Gebrauchs-
Aufstelanweisung
52 7895
(pl)

Programmtabelle
58 1633
(pl)

1) 36 9645
(pl)

Zubehör:
Bodenbefestigung
WMZ2200
Verlängerung für
Aqua-Stop
Verlängerung 2,5m
WMZ2380
Unterbauzubehör
WMZ2390

Mat. – Nr. – Konstante
3740

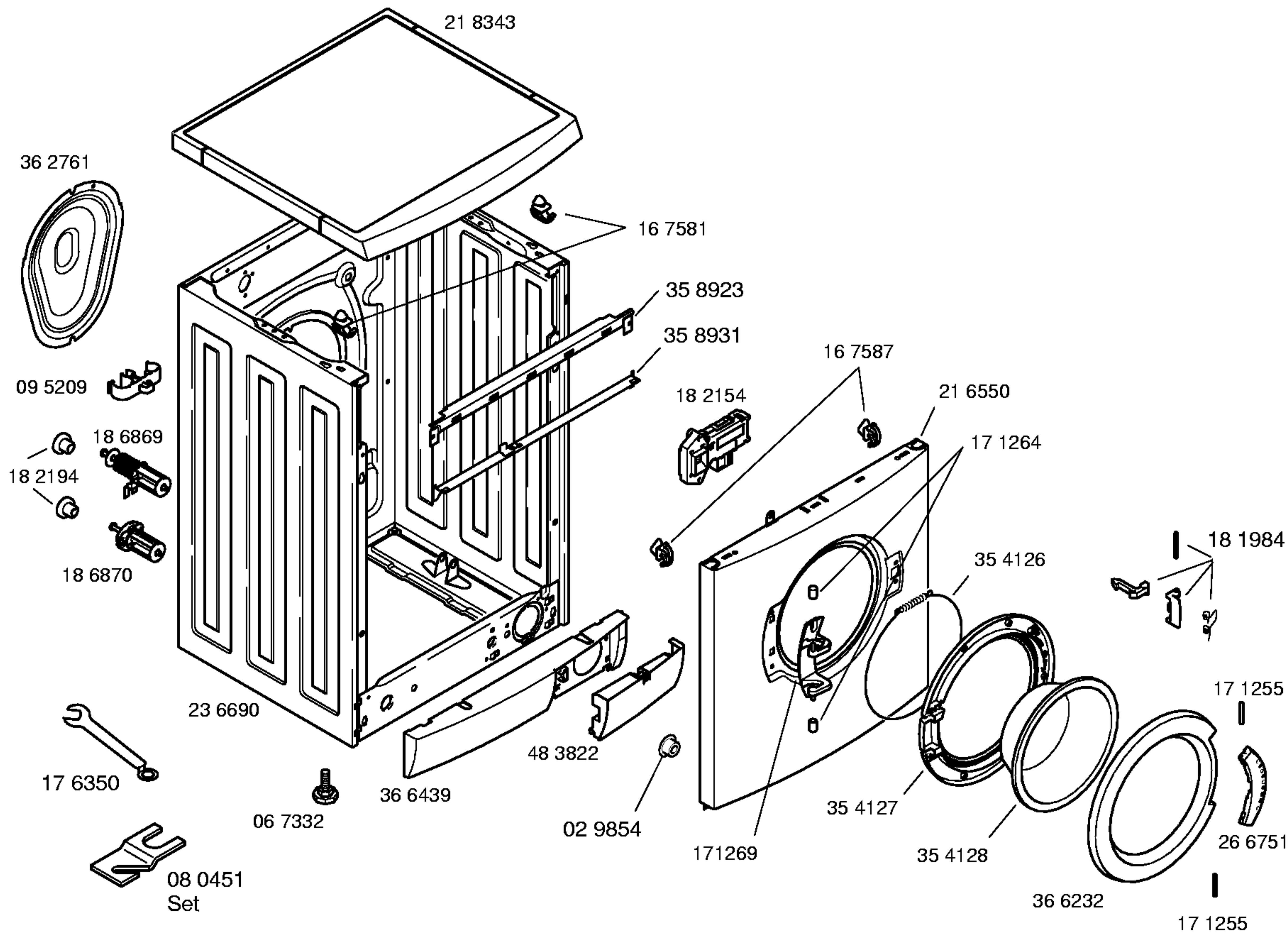

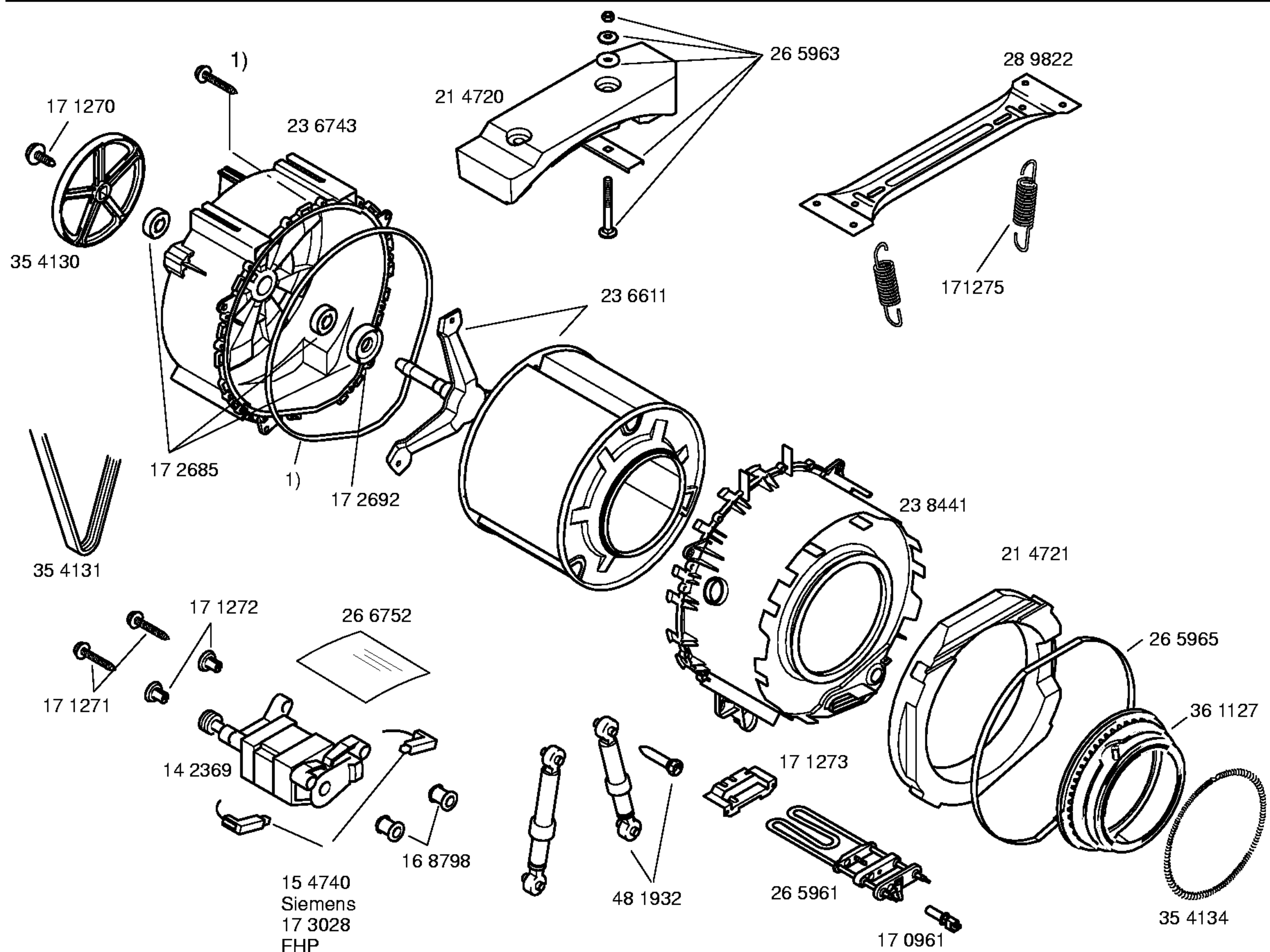

Mat. – Nr. – Konstante
3740

1) 26 5964

Mat. – Nr. – Konstante
3740

