

**SECTION 2**  
**CABINET & MAIN CHASSIS**

**CONTENTS**

**EXPLODED VIEWS .....2-2**

- 1. CABINET AND MAIN FRAME SECTION .....2-2**
- 2. DECK MECHANISM SECTION(RS-01A) .....2-3**
- 3. SPEAKER SECTION .....2-4**
- 4. PACKING ACCESSORY SECTION .....2-9**



## 2. DECK MECHANISM SECTION(RS-01A)

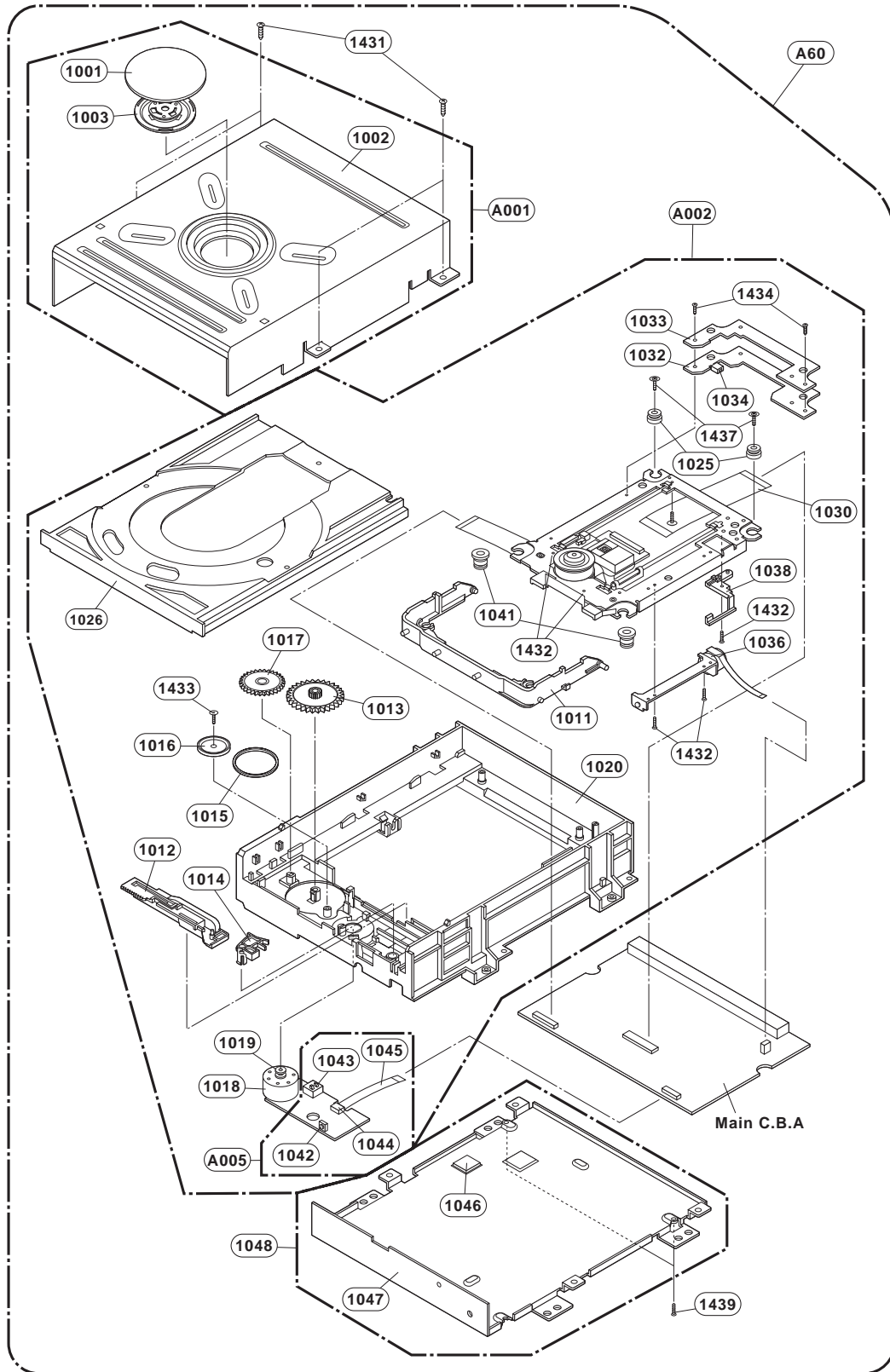

**3. SPEAKER SECTION(LHS-36SE5)**  
**• FRONT/REAR/CENTER SPEAKER(LHS-36SE5S)**

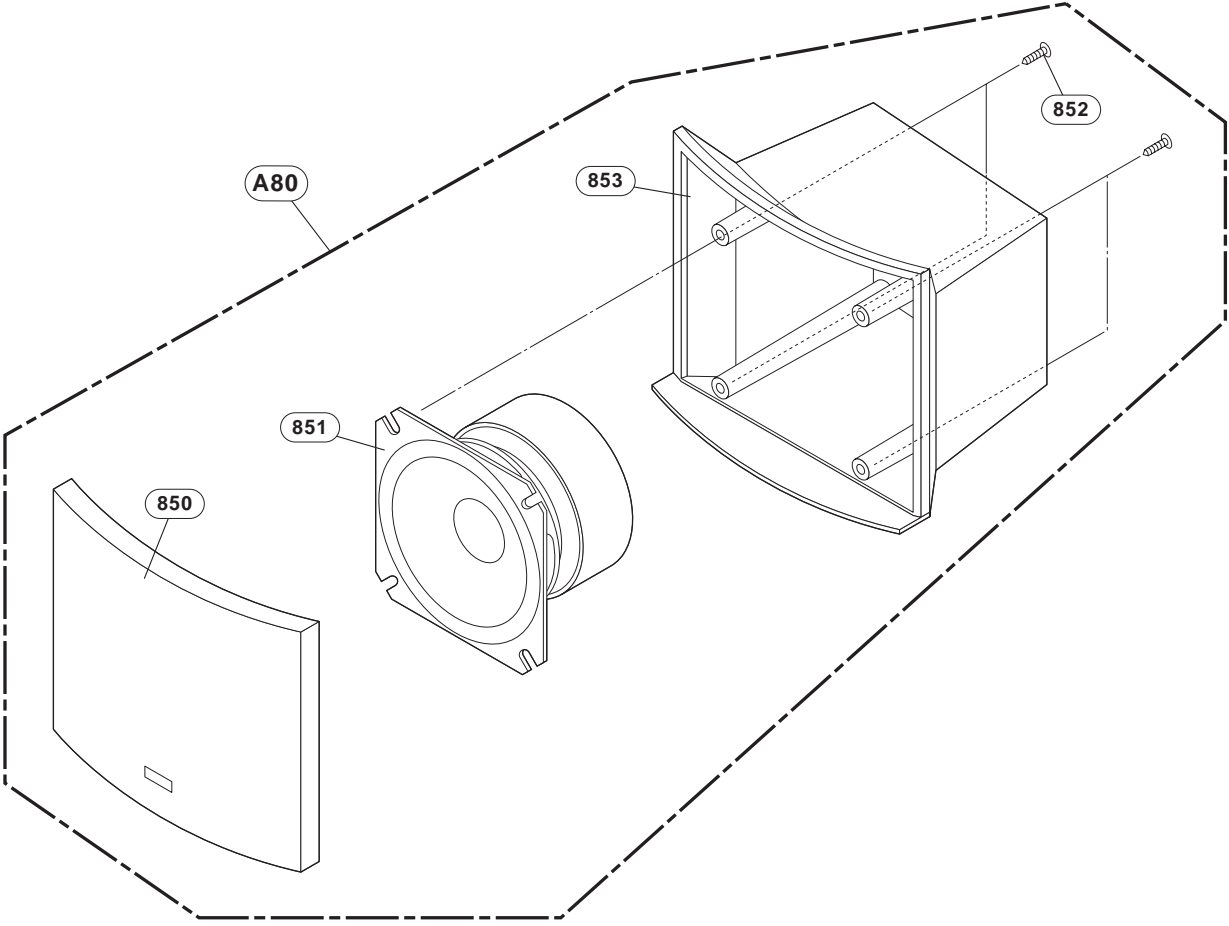

• ACTIVE SUBWOOFER SPEAKER(LHS-36SE5W)

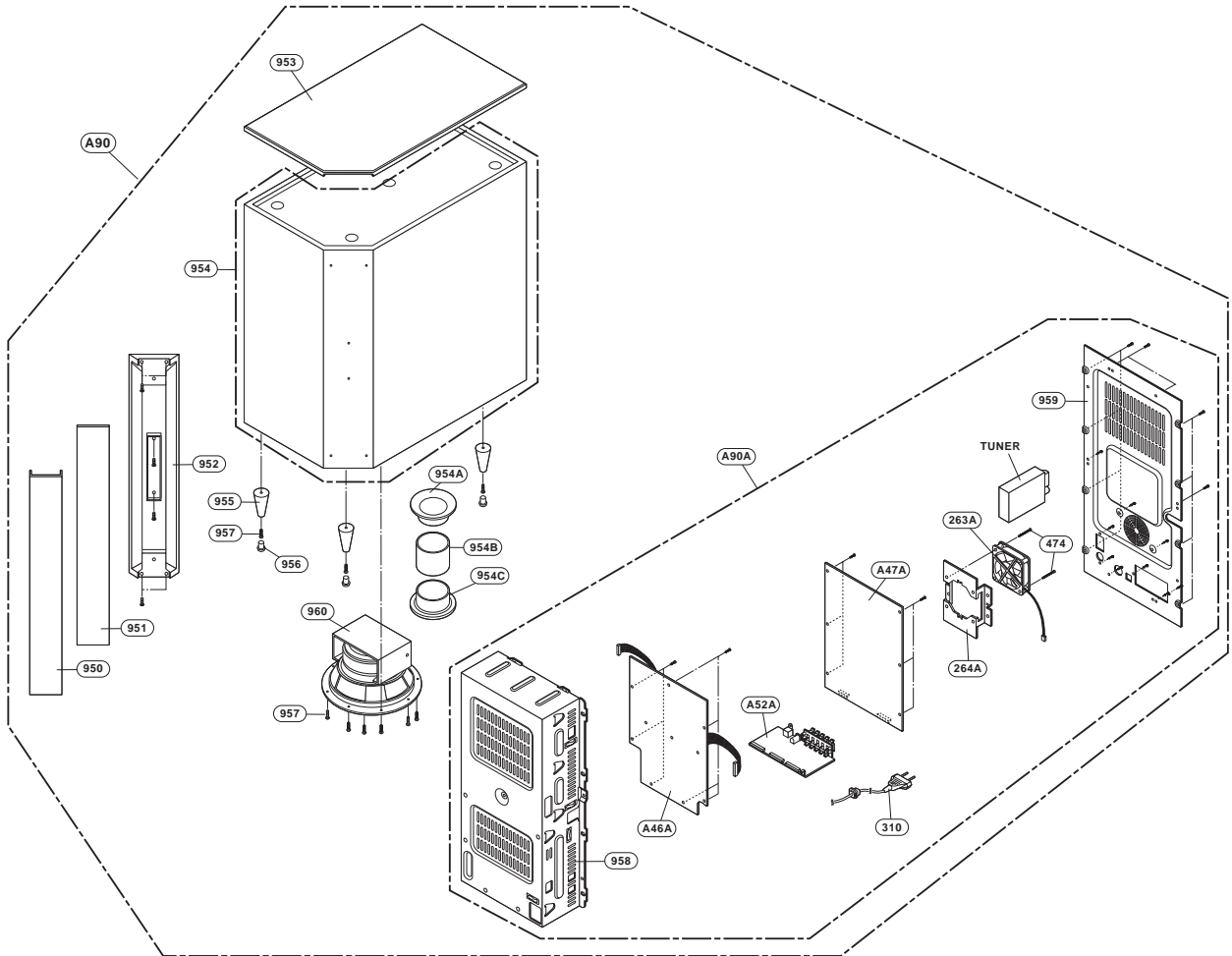

**3. SPEAKER SECTION(LHS-76IA5)**  
• **CENTER SPEAKER(LHS-76/96IA5C)**

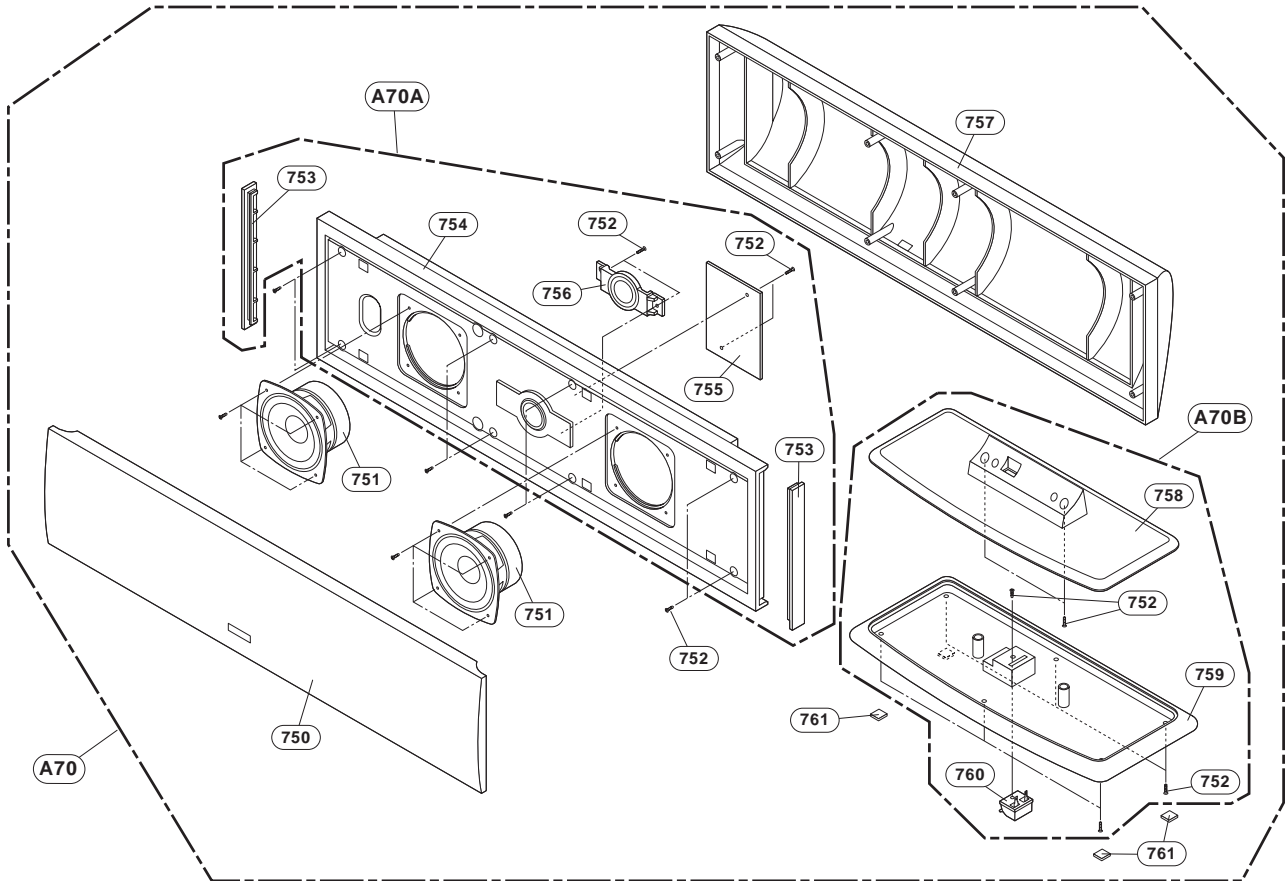

• FRONT/SATELLITE SPEAKER(LHS-76/96IA5S)

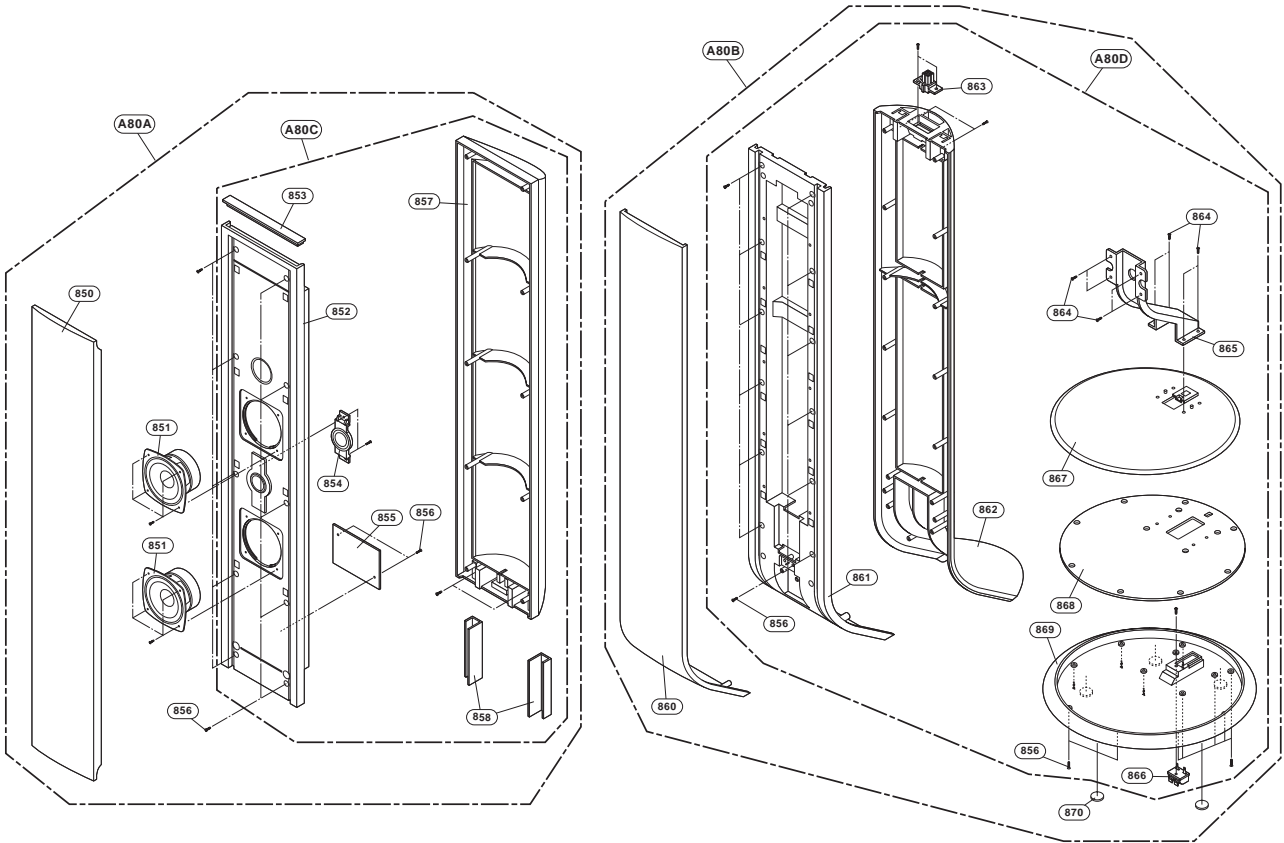





## 4. PACKING ACCESSORY SECTION

