

S/M No.: C1B4K0S002

# Service Manual

Microwave Oven

Model : KOC-1B4K0S

KOC-1B4K5S

## ✓ Caution

: In this Manual, some parts can be changed for improving, their performance without notice in the parts list. So, if you need the latest parts information, please refer to PPL(Parts Price List) in Service Information Center (<http://svc.dwe.co.kr>).



DAEWOO ELECTRONICS CO., LTD.  
<http://svc.dwe.co.kr>

DAEWOO

# PRECAUTIONS TO BE OBSERVED BEFORE AND DURING SERVICING TO AVOID POSSIBLE EXPOSURE TO EXCESSIVE MICROWAVE ENERGY

- (a) Do not operate or allow the oven to be operated with the door open.
- (b) Make the following safety checks on all ovens to be serviced before activating the magnetron or other microwave source, and make repairs if necessary: (1) Interlock operation, (2) Proper door closing, (3) Seal and sealing surfaces (arcing, wear, and other damage), (4) Damage to or loosening of hinges and latches (5) Evidence of dropping or abuse.
- (c) Before turning on power to the microwave oven for any service test or inspection within the microwave generating compartments, check the magnetron, wave guide or transmission line, and cavity for proper alignment, integrity, and connections.
- (d) Any defective or misadjusted components in the interlock, monitor, door seal and microwave generation and transmission systems shall be repaired, replaced, or adjusted by procedures described in this manual before the oven is released to the owner.

A microwave leakage check to verify compliance with the Federal performance standard should be performed on each oven prior to release to the owner.

## TABLE OF CONTENTS

<b>1. SAFETY AND PRECAUTIONS</b> .....	<b>2</b>
<b>2. SPECIFICATIONS</b> .....	<b>3</b>
<b>3. EXTERNAL VIEW</b> .....	<b>3</b>
3-1. OUTER DIMENSION .....	3
3-2. FEATURE DIAGRAM .....	4
<b>4. INSTALLATION</b> .....	<b>5</b>
<b>5. CONTROL PANEL</b> .....	<b>6</b>
<b>6. DISASSEMBLY AND ASSEMBLY</b> .....	<b>7</b>
<b>7. INTERLOCK MECHANISM AND ADJUSTMENT</b> .....	<b>17</b>
<b>8. TROUBLE SHOOTING GUIDE</b> .....	<b>18</b>
<b>9. MEASUREMENT AND TEST</b> .....	<b>24</b>
9-1. MEASUREMENT OF THE MICROWAVE POWER OUTPUT .....	24
9-2. MICROWAVE RADIATION TEST .....	25
9-3. COMPONENT TEST PROCEDURE.....	26
9-4. COMPONENT ACTION.....	27
<b>10. WIRING DIAGRAM</b> .....	<b>28</b>
<b>11. EXPLODED VIEW AND PARTS LIST</b> .....	<b>29</b>
11-1. DOOR ASSEMBLY .....	29
12-2. CONTROL PANEL ASSEMBLY.....	29
13-3. TOTAL ASSEMBLY .....	29
<b>12. PRINTED CIRCUIT BOARD</b> .....	<b>33</b>
<b>13. P.C.B CIRCUIT DIAGRAM</b> .....	<b>37</b>

# 1. SAFETY AND PRECAUTIONS

---

## 1. FOR SAFE OPERATION

Damage that allows the microwave energy (that cooks or heats the food) to escape will result in poor cooking and may cause serious bodily injury to the operator.

**IF ANY OF THE FOLLOWING CONDITIONS EXIST, OPERATOR MUST NOT USE THE APPLIANCE.**

(Only a trained service personnel should make repairs.)

- (1) A broken door hinge.
- (2) A broken door viewing screen.
- (3) A broken front panel, oven cavity.
- (4) A loosened door lock.
- (5) A broken door lock.

The door gasket plate and oven cavity surface should be kept clean.

No grease, soil or spatter should be allowed to build up on these surfaces or inside the oven.

**DO NOT ATTEMPT TO OPERATE THIS APPLIANCE WITH THE DOOR OPEN.**

The microwave oven has concealed switches to make sure the power is turned off when the door is opened.

Do not attempt to defeat them.

**DO NOT ATTEMPT TO SERVICE THIS APPLIANCE UNTIL YOU HAVE READ THIS SERVICE MANUAL.**

## 2. FOR SAFE SERVICE PROCEDURES.

1. If the oven is operative prior to servicing, a microwave emission check should be performed prior to servicing the oven.
2. If any certified oven unit is found to servicing, a microwave emission check should be performed prior to servicing the oven.
  - (1) inform the manufacturer, importer or assembler,
  - (2) repair the unit at no cost to the owner,
  - (3) attempt to ascertain the cause of the excessive leakage,
  - (4) tell the owner of the unit not to use the unit until the oven has been brought into compliance.
3. If the oven operates with the door open, the service person should tell the user not to operate the oven and contact the manufacturer immediately.

## IMPORTANT

The wire in this mains lead coloured in accordance with the following code.

Green-and-yellow	: Earth
Blue	: Neutral
Brown	: Live

As the colours of the wires in the mains lead of this appliance may not correspond with the coloured markings identifying the terminals in your plug, proceed as follows:

The wire which is coloured green-and-yellow must be connected to the terminal in the plug which is marked with the letter E , earth symbol or coloured green-and-yellow.

The wire which is coloured blue must be connected to the terminal which is marked with the letter N or coloured black.

The wire which is coloured brown must be connected to the terminal which is marked with the letter L or coloured red.

**NOTE :** This oven is designed for counter-top use only.

## 2. SPECIFICATIONS

MODEL		KOC-1B4K0S	KOC-1B4K5S
POWER SUPPLY		230V~50HZ, SINGLE PHASE WITH EARTHING	
POWER CONSUMPTION	MICROWAVE	1500W	
	GRILL 1600W		
	CONVECTION	2300W	
	COMBINATION	3100W	2300W
MICROWAVE ENERGY OUTPUT		1000W(IEC705)	
MICROWAVE FREQUENCY		2450MHz	
OUTSIDE DIMENSIONS (W X H X D)		560X344X543mm (22.0X13.5X21.3 in.)	
CAVITY DIMENSIONS (W X H X D)		368.5X246X376.5mm (14.5X9.7X14.8 in.)	
NET WEIGHT		APPROX. 21.5kg (47.6 lbs.)	
TIMER		60 minutes	
FUNCTION SELECTIONS		MICROWAVE/ GRILL/ CONVECTION/ COMBINATION	
POWER SELECTIONS		10 LEVELS	
CAVITY VOLUME		1.2 Cu. Ft	

\* Specifications are subject to change without notice.

## 3. EXTERNAL VIEW

### 1. OUTER DIMENSION

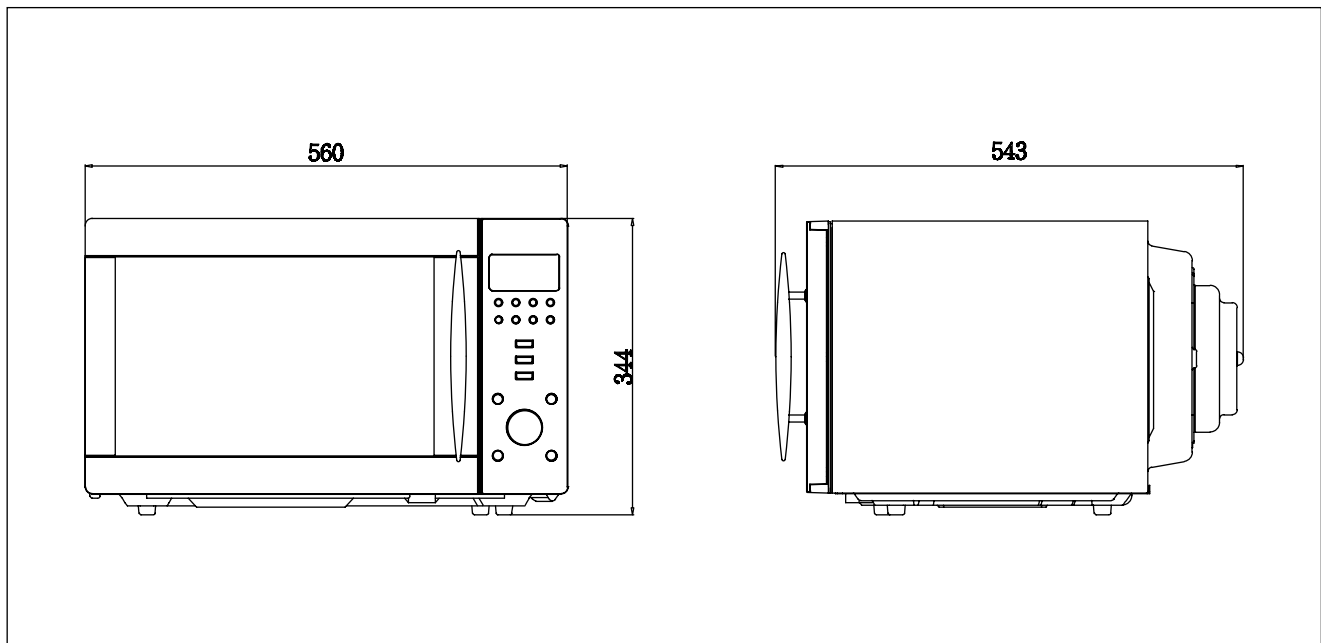

## 2. FEATURE DIAGRAM

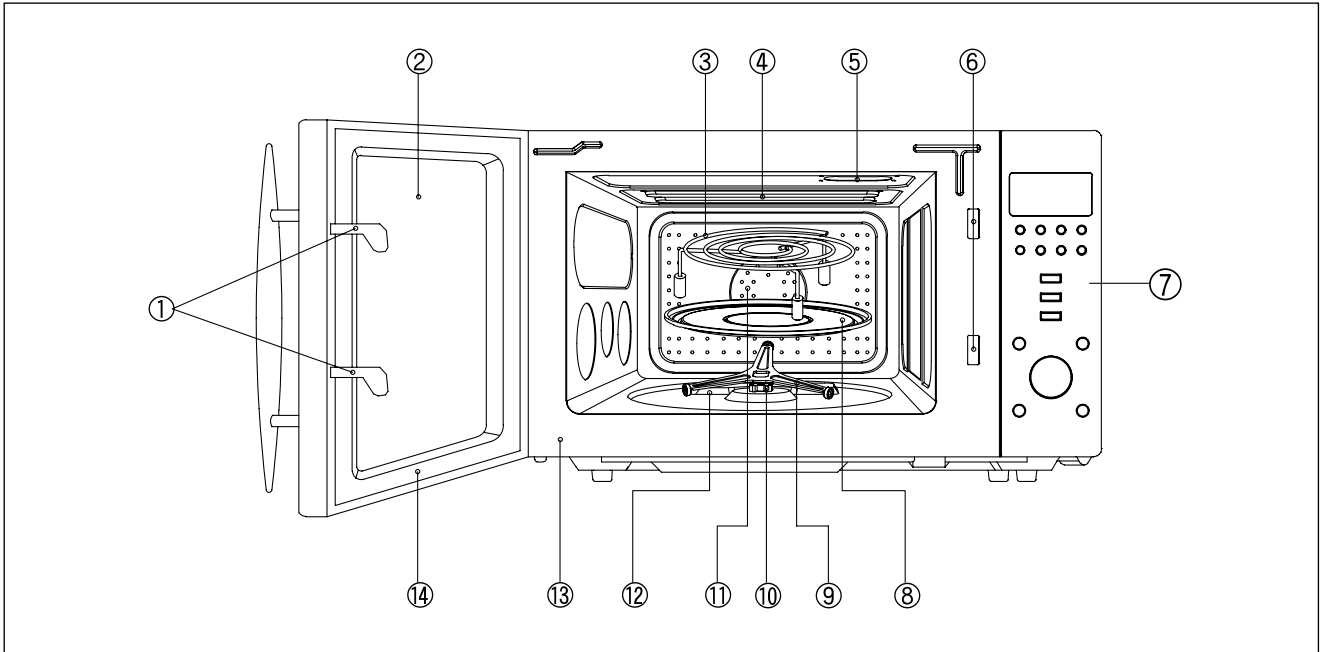

### 1. DOOR HOOK

When the door is closed, it will automatically lock shut. If door is opened while oven is operating, the magnetron will immediately stop operating.

### 2. DOOR VIEWING SCREEN

Allows viewing of food. The screen is designed so that light can pass through, but not the microwave.

### 3. METAL RACK

### 4. TOP HEATER

Turns on when convection, grill and combi cooking is selected.

### 5. OVEN LAMP

Automatically turns on during oven operating.

### 6. SAFETY INTERLOCK SYSTEM

### 7. CONTROL PANEL

### 8. TURNTABLE TRAY

Rotates during cooking and ensure even distribution of Microwaves.  
It can also be used as a cooking utensil.

### 9. ROLLER GUIDE

This must always be used for cooking together with the turntable tray.

### 10. COUPLER

This fits over the shaft in the center of the ovens cavity floor. This is to remain in the oven for all cooking.

### 11. CONVECTION OUTLET & FAN

### 12. UNDER HEATER

### 13. OVEN FRONT PLATE

### 14. DOOR SEAL

Door seal maintains the microwave energy within the oven cavity and prevents microwave leakage.

## 4. INSTALLATION

---

### 1. Steady, flat location

This microwave oven should be set on a steady, flat surface.  
This microwave oven is designed for counter top use only.

### 2. Leave space behind and side

All air vents should be kept a clearance. If all vents are covered during operation, the oven may overheat and, eventually, cause failure.

### 3. Away from Radio and TV sets

Poor television reception and radio interference may result if the oven is located close to a TV, Radio, antenna or feeder and so on.  
Position the oven as far from them as possible.

### 4. Away from heating appliances and water taps

Keep the oven away from hot air, steam or splash when choosing a place to position it, or the insulation might be adversely affected and breakdowns occur.

### 5. Power supply

- Check your local power source. This microwave oven requires a current of approximately 12 amperes, 230V, 50Hz.
- Power supply cord is about 1.2 meters long.
- The voltage used must be the same as specified on this oven. Using a higher voltage may result in a fire or other accident causing oven damage. Using low voltage will cause slow cooking. We are not responsible for damage resulting from use of this oven with a voltage of ampere fuse other than those specified.
- This appliance is supplied with cable of special type, which, if damaged, must be repaired with cable of same type.
- Such a cable can be purchased from DAEWOO and must be installed by a Qualified Person.

### 6. Examine the oven after unpacking for any damage such as:

A misaligned door, broken door or a dent in cavity.  
If any of the above are visible, DO NOT INSTALL, and notify dealer immediately.

### 7. Do not operate the oven if it is colder than room temperature.

(This may occur during delivery in cold weather.) Allow the oven to become room temperature before operating.

## EARTHING INSTRUCTIONS

---

This appliance must be earthed. In the event of an electrical short circuit, earthing reduces the risk of the electric shock by providing an escape wire for the electric current. This appliance is equipped with a cord having a earthing wire with a earthing plug. The plug must be plugged into an outlet that is properly installed and earthed.

### WARNING

Improper use of the earthing plug can result in a risk of electric shock.

Consult a qualified electrician or serviceman if the earthing instructions are not completely understood, or if doubt exists as to whether the appliance is properly earthed, and either:

If it is necessary to use an extension cord, use only a 3-wire extension cord that has a 3-blade earthing plug, and a 3-slot receptacle that will accept the plug on the appliance.

The marked rating of the extension cord should be equal to or greater than the electrical rating of the appliance, or  
Do not use an extension cord.

# 5. CONTROL PANEL

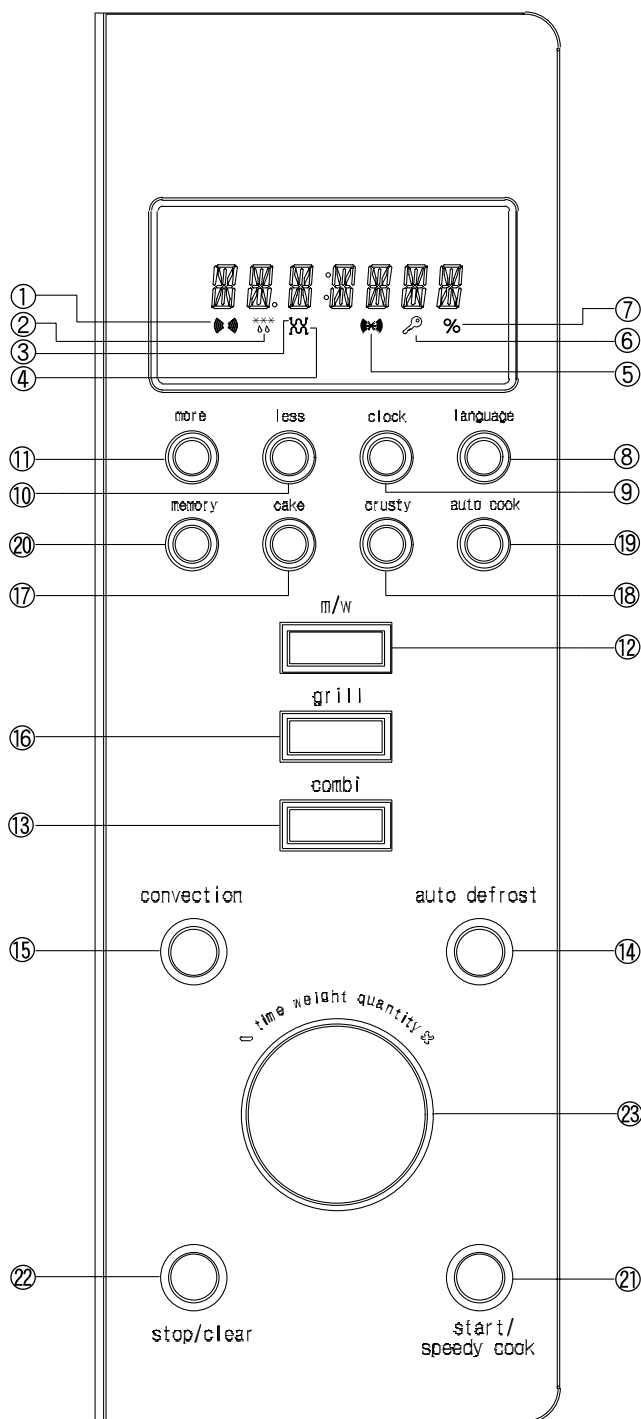

## DISPLAY WINDOW

1. **MICROWAVE** - indicator, showing microwaving in progress.
2. **DEFROST**- indicator, showing defrosting in progress.
3. **GRILL(upper grill heater)** - indicator, showing griling in progress.
4. **GRILL(lower grill heater)** - indicator, showing griling in progress.
5. **CONVECTION** - indicator, showing convectioning in progress.
6. **CHILD LOCK** - indicator.
7. **%** - percentage microwave power level indicator.

## BUTTONS

8. **language** - Press to select the language.
9. **clock** - Use to set clock.
10. **less** - Use to remove time from cooking.
11. **more** - Use to add time to cooking.
12. **m/w** - Press to select microwave power level.
13. **combi** - Press to select combi cooking mode.
14. **auto defrost** - Press to select defrost menu.
15. **convection** - Press to select convection temperature.
16. **grill** - Press to select grill.
17. **cake** - Press to select cake menu.
18. **crusty** - Press to select crusty menu.
19. **auto cook** - Press to select auto cook menu.
20. **memory** - Use to set favorite cooking mode.
21. **start/speedy cook** - Press to start a programme, also for speedy start (each press adds 30 seconds microwave cooking time).
22. **stop/clear** - Press once to stop a programme, and twice to cancel a programme.
23. **dial knob** - Use to set time, weight and quantity.

## 6. DISASSEMBLY AND ASSEMBLY

### - Cautions to be observed when trouble shooting.

Unlike many other appliances, the microwave oven is high-voltage, high-current equipment. It is completely safe during normal operation. However, carelessness in servicing the oven can result in an electric shock or possible danger from a short circuit. You are asked to observe the following precautions carefully.

1. Always remove the power plug from the outlet before servicing.
2. Use an insulated screwdriver and wear rubber gloves when servicing the high voltage side.
3. Discharge the high voltage capacitor before touching any oven components or wiring.

(1) Check the grounding.

Do not operate on a two-wire extension cord.

The microwave oven is designed to be used while grounded.

It is imperative, therefore, to make sure it is grounded properly before beginning repair work.

(2) Warning about the electric charge in the high voltage capacitor.

For about 30 seconds after the operation has stopped, electric charge remains in the high voltage capacitor.

When replacing or checking parts, short between oven chassis and the negative high terminal of the high voltage capacitor by using a properly insulated screwdriver to discharge.

4. When the 15A fuse is blown out due to the operation of the monitor switch; replace primary interlock switch, secondary interlock switch and interlock monitor switch.
5. After repair or replacement of parts, make sure that the screws are properly tightened, and all electrical connections are tightened.
6. Do not operate without cabinet.

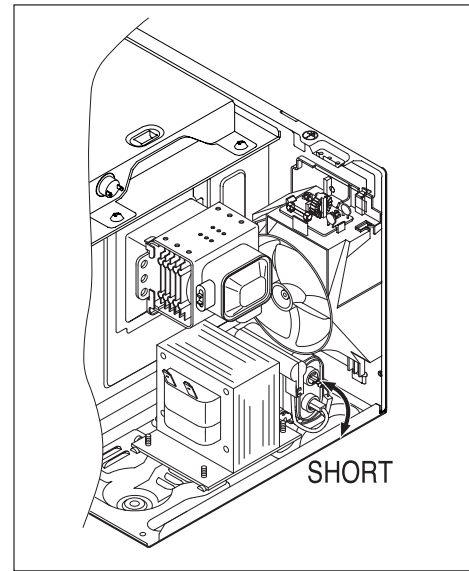

**CAUTION** : Service personnel should remove their watches whenever working close to or replacing the magnetron.

**WARNING** : When servicing the appliance, take care when touching or replacing high potential parts because of electrical shock or exposing microwave. These parts are as follows - HV Transformer, Magnetron, HV Capacitor, HV Diode.



✓ **Caution:** In this Service Manual, some parts can be changed for improving, their performance without notice in the parts list. So, if you need the latest parts information, please refer to PPL(Parts Price List) in Service information Center(<http://svc.dwe.co.kr>)

### 1. To remove cabinet

- 1) Remove four screws on cabinet back.
- 2) Push the cabinet backward.

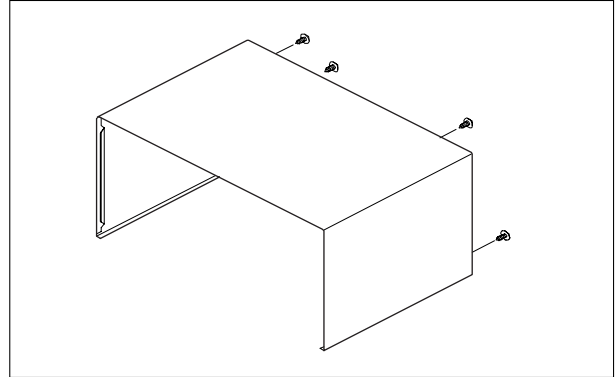

### 2. To remove guide wind assembly

- 1) Remove two screws which secure the stopper hinge top.
- 2) Remove the door assembly from top plate of cavity.
- 3) Reverse the above for assembly.

**NOTE:** After replacting the door assembly, perform a check of correct alignment with the hinge and cavity front plate.

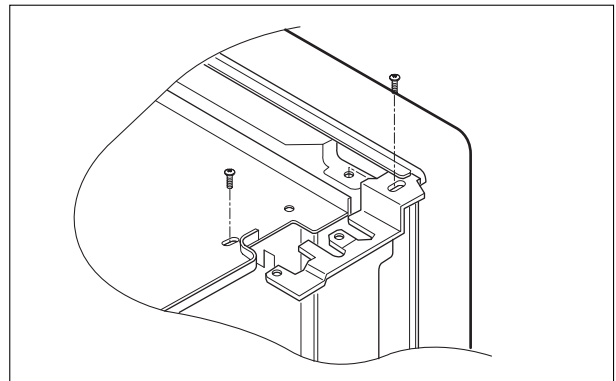

### 3. To remove door parts.

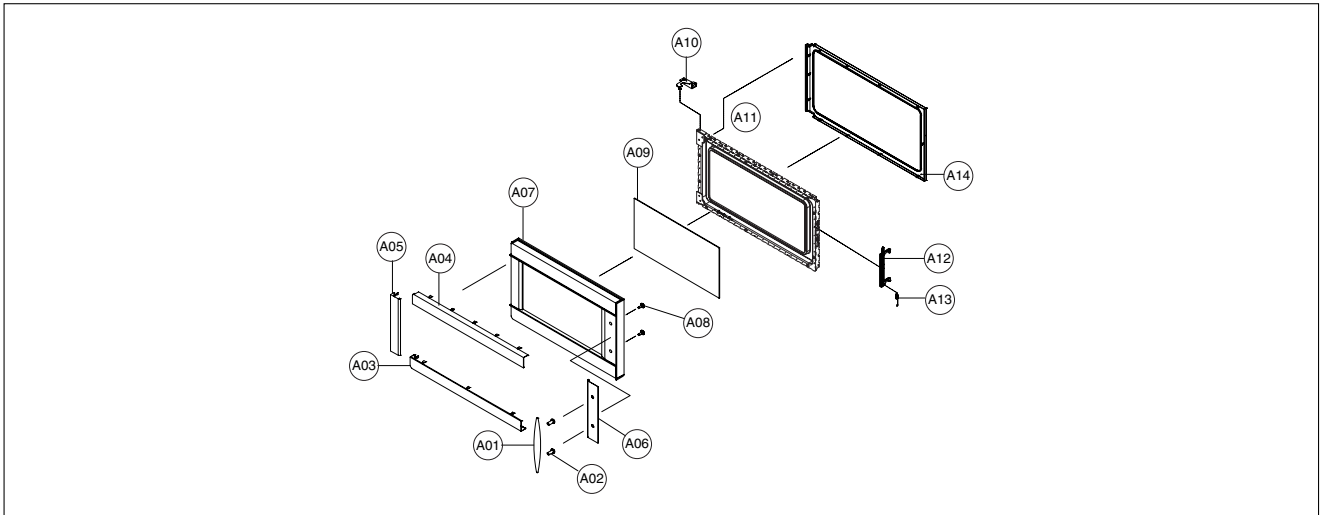

REF NO.	PART CODE	PART NAME	DESCRIPTION	Q TY	REMARK
A01	3512603520	HANDLE DOOR	ALUMINUM	1	
A02	3515307400	SUPPORTER HANDLE	KOC-1B4K0S	2	
A03	3511605500	DECORATOR DOOR *U	STS304 T0.5	1	
A04	3511605400	DECORATOR DOOR *T	STS304 T0.5	1	
A05	3511605700	DECORATOR DOOR *L	STS304 T0.5	1	
A06	3511605600	DECORATOR DOOR *R	STS304 T0.5	1	
A07	3512204740	FRAME DOOR	PC	1	
A08	7001503511	SCREW MACHINE	PAN 5X35 MFZN	2	
A09	3517004090	BARRIER-SCREEN *O	TEMP GLASS T3.2	1	
A10	3515204900	STOPPER HINGE *T AS	KOC-1B4K0S	1	
A11	3516602100	DOOR-PLATE	SBHG-1A T0.7	1	
A12	3513101200	HOOK	POM	1	
A13	3515101800	SPRING HOOK	PW1	1	
A14	3512302300	GASKET DOOR	PRT	1	

- 
- (1) Remove the gasket door(A14) from door plate.
  - (2) Remove two screws(A08) from door plate.
  - (3) Remove the door handle (A01) and handle supporter (A02) from door plate.
  - (4) Remove the four door decorators (A03~A06) from door frame.
  - (5) Remove the door frame (A07) from door plate.
  - (6) Remove the stopper hinge top(A10) from door plate.
  - (7) Remove the spring(A13) and the hook(A12).
  - (8) Remove the barrier screen outer(A09) from door frame.
  - (9) Reverse the above steps for reassembly.

#### 4. Method to reduce the gap between the door seal and the oven front surface.

- (1) To reduce gap located on part A .
  - Loosen two screws on stopper hinge top, and then push the door to contact the door seal to oven front surface.
  - Tighten two screws.
- (2) To reduce gap located on part B .
  - Loosen two screws on stopper hinge under, and then push the door to contact the door seal to oven front surface.
  - Tighten two screws.

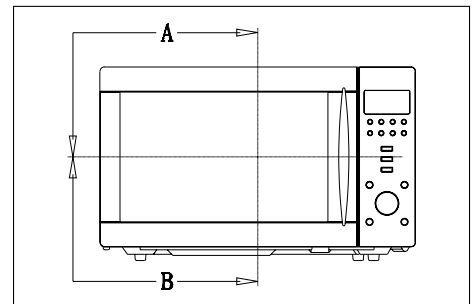

**NOTE :** A small gap may be acceptable if the microwave leakage does not exceed 4mW/cm<sup>2</sup>.

✓ **Caution:** In this Service Manual, some parts can be changed for improving, their performance without notice in the parts list. So, if you need the latest parts information, please refer to PPL(Parts Price List) in Service information Center(<http://svc.dwe.co.kr>)

## 5. To remove control panel parts.

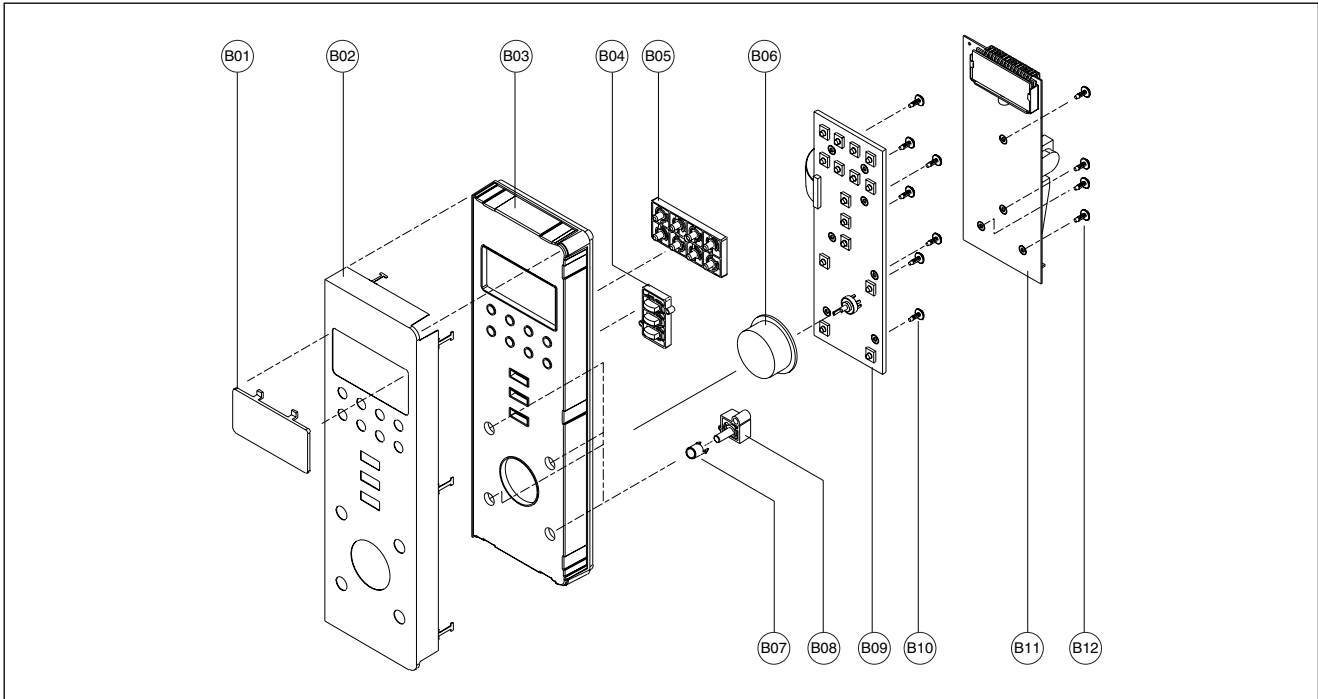

REF NO.	PART CODE	PART NAME	DESCRIPTION	QTY	REMARK
B01	3515501720	WINDOW DISPLAY	SAN	1	
B02	3511605020	DECORATOR C/PANEL	STS 304 T0.5 HL	1	
B03	3516724140	C-PANEL	ABS XR-401 H-2938	1	
B04	3516908440	BUTTON FUNCTION-B	ABS SG-175 SG-0760D	1	
B05	3516908340	BUTTON FUNCTION-A	ABS XR-401 H-2938	1	
B06	3513406040	KNOB VOLUME	ABS SG-175 SG-0760D	1	
B07	3511605120	DECORATOR RING	ABS	4	
B08	3516908540	BUTTON FUNCTION-C	ABS SG-175 SG-0760D	4	
B09	3514323130	SUB PCB ASS Y	KOC-1B4K	1	
B10	7121301011	SCREW TAPPING	T2S PAN 3X10 MFZN	7	
B11	PKMPMSAD00	MAIN PCB ASSY	KOC-1B4K0S	1	
	PKMPMSAD20		KOC-1B4K5S	1	
B12	7122401211	SCREW TAPPING	T2S TRS 4X12 MFZN	4	

- (1) Remove four screws(B12) which secure the control panel.
- (2) Pull out the Main PCB assembly(B11).
- (3) Remove seven screws(B10) which secure the control panel.
- (4) Pull out the Sub PCB assembly(B09).
- (5) Pull out the Knob volume(B06) from the Sub PCB assembly.
- (6) Pull out six buttons from the control panel.
- (7) Pull out Decorator ring(B07) and Window display (B01) from the control panel.
- (8) Pull out the Decorator c-panel (B02) from the control panel.
- (9) Reverse the above steps for reassembly.

## 6. To remove high voltage capacitor.

- 1) Remove a screw which secure the grounding ring terminal of the H.V. diode and the capacitor holder.
- 2) Remove the H.V. diode from the capacitor holder.
- 3) Reverse the above steps for reassembly.

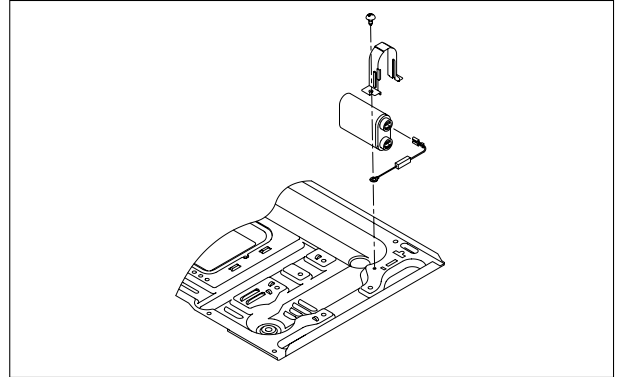

## ◆ High voltage circuit wiring

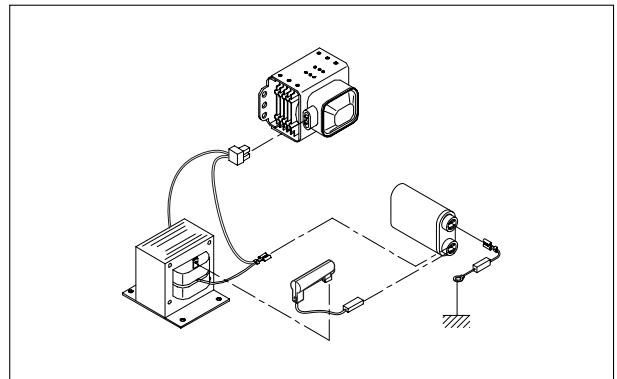

## 7. To remove magnetron.

- 1) Remove a screw which secure the magnetron.
- 2) Remove the magnetron.
- 3) Reverse the above steps for reassembly.

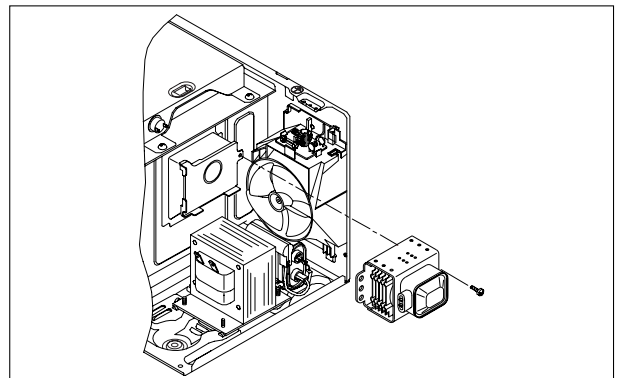

**CAUTION :** Never install the magnetron without the metallic gasket plate which is packed with each magnetron to prevent microwave leakage. Whenever repair work is carried out on magnetron, check the microwave leakage. It shall not exceed  $4\text{mW}/\text{cm}^2$  for a fully assembled oven with door normally closed.

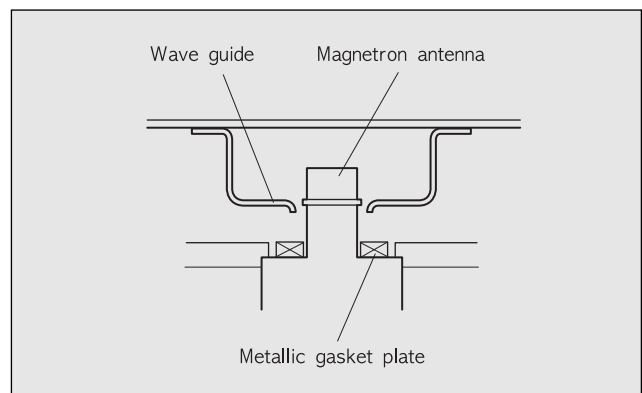
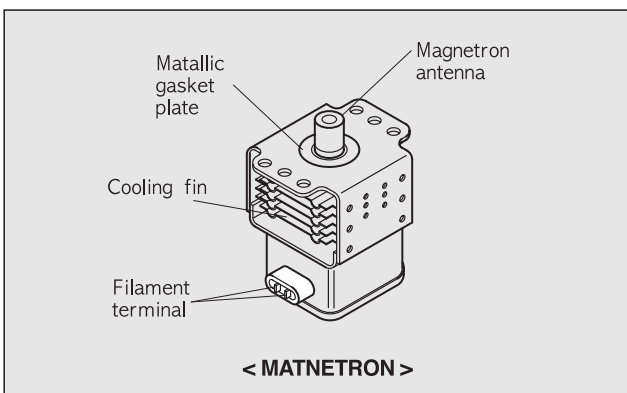

## 8. To remove wind guide assembly.

- 1) Remove a screw for earthing.
- 2) Remove the noise filter from the wind guide.
- 3) Remove a screw which secure the wind guide assembly.
- 4) Draw forward the wind guide assembly.
- 5) Pull the fan from the motor shaft.
- 6) Remove two screws which secure the motor shaded pole.
- 7) Remove the motor shaded pole.
- 8) Reverse the above steps for reassembly.

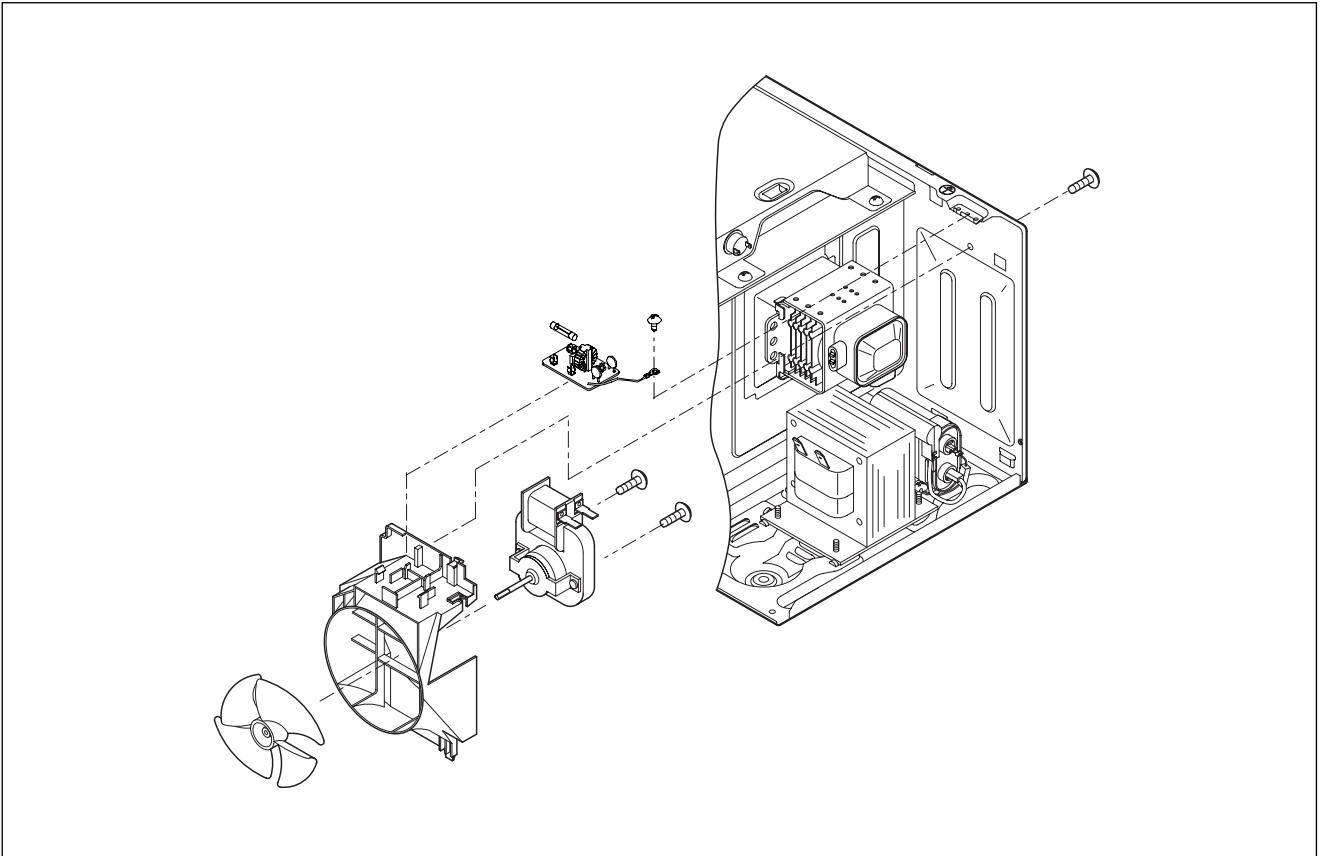

## 9. To remove H.V.transformer.

- 1) Remove four screws holding the H.V.transformer.
- 2) Remove the H.V.transformer.
- 3) Reverse the above steps for reassembly.

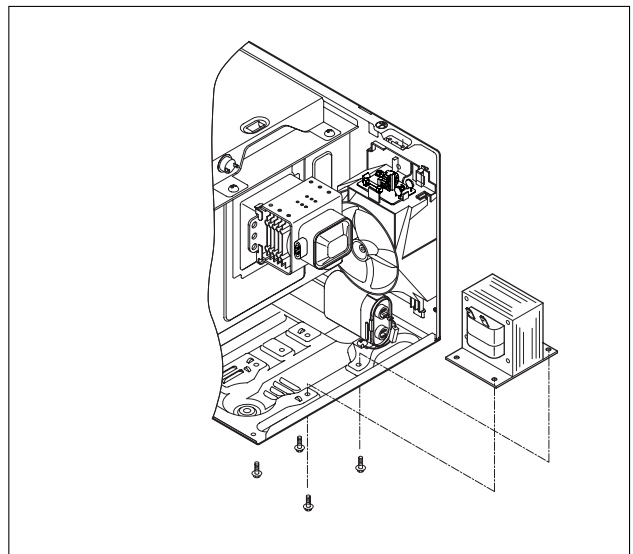

✓ **Caution:** In this Service Manual, some parts can be changed for improving, their performance without notice in the parts list. So, if you need the latest parts information, please refer to PPL(Parts Price List) in Service information Center(<http://svc.dwe.co.kr>)

## 10. To remove Lamp assembly parts.

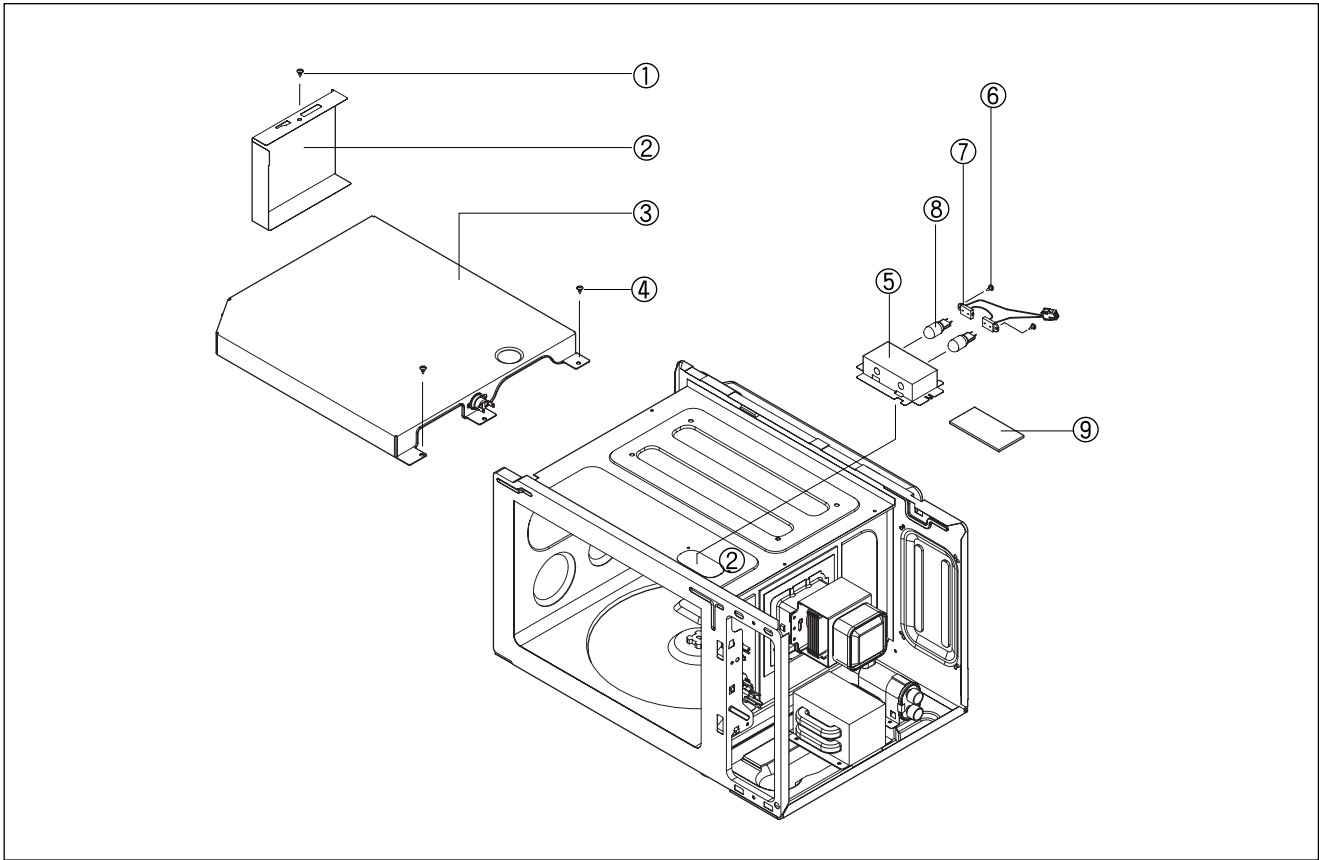

REF NO.	PART CODE	PART NAME	DESCRIPTION	Q TY	REMARK
1	7112401011	SCREW TAPPING	T1 TRS 4X10 MFZN	1	
2	3512520500	GUIDE AIR OUTLET	SA1D T0.5	1	
3	3513303000	INSULATOR HEATER*T	SECC T0.5	1	
4	7112401011	SCREW TAPPING	T1 TRS 4X10 MFZN	2	
5	3511407800	COVER LAMP	STS430 T0.5	1	
6	7112401011	SCREW TAPPING	T1 TRS 4X10 MFZN	2	
7	3513003900	HOLDER LAMP AS	KOC-1B0K0S	1	
8	3513602600	LAMP	HALOGEN	2	
9	3511407810	COVER LAMP	GLASS T2.0	1	

- 1) Remove a screw ① and pull out Guide air outlet ②.
- 2) Remove two screws ④ and pull out insulator heater \*t③.
- 3) Pull out the Lamp assembly.
- 4) Remove two screws ⑥ pull out the Lamp assembly.
- 5) Pull out the Holder lamp assembly ⑦ from the Cover lamp ⑤.
- 6) Pull out the Lamp ⑧ from the Holder lamp assembly ⑦.
- 7) Reverse the above steps for reassembly.

✓ **Caution:** In this Service Manual, some parts can be changed for improving, their performance without notice in the parts list. So, if you need the latest parts information, please refer to PPL(Parts Price List) in Service information Center(<http://svc.dwe.co.kr>)

## 11. To remove Top heater assembly parts.

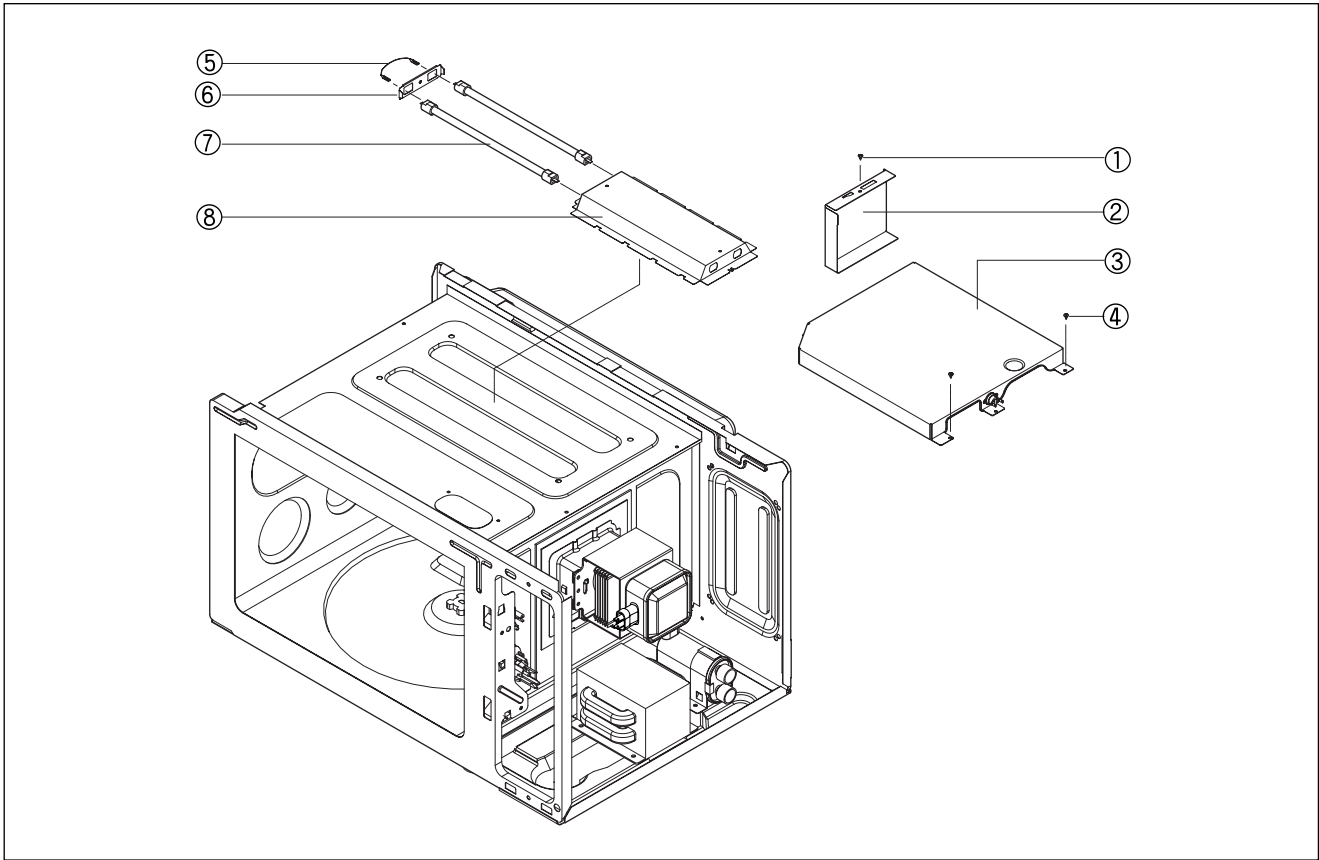

REF NO.	PART CODE	PART NAME	DESCRIPTION	Q TY	REMARK
1	7112401011	SCREW TAPPING	T1 TRS 4X10 MFZN	1	
2	3512520500	GUIDE AIR OUTLET	SA1D T0.5	1	
3	3513303000	INSULATOR HEATER*T	SECC T0.5	1	
4	7112401011	SCREW TAPPING	T1 TRS 4X10 MFZN	2	
5	3512767000	HARNESS HEATER	KOC-1B0K0S	1	
6	3510607700	BRACKET HEATER *T	SA1D T0.5	1	
7	3512803800	HEATER MIRACLON	115V 550W 270MM	2	
8	3511407600	COVER HEATER *T	STS430 T0.5	1	

- 1) Remove a screw ① and pull out Guide air outlet ②.
- 2) Remove two screws ④ and pull out insulator heater \*t ③.
- 3) Pull out the Top heater assembly.
- 4) Pull out the Harness heater ⑤.
- 5) Pull out the Braket heater\*t ⑥ from the Cover heater\*t ⑧.
- 6) Pull out the Heater miraclon ⑦ from the Cover heater\*t ⑧.
- 7) Reverse the above steps for reassembly.

✓ **Caution:** In this Service Manual, some parts can be changed for improving, their performance without notice in the parts list. So, if you need the latest parts information, please refer to PPL(Parts Price List) in Service information Center(<http://svc.dwe.co.kr>)

## 12. To remove Rear heater assembly parts.

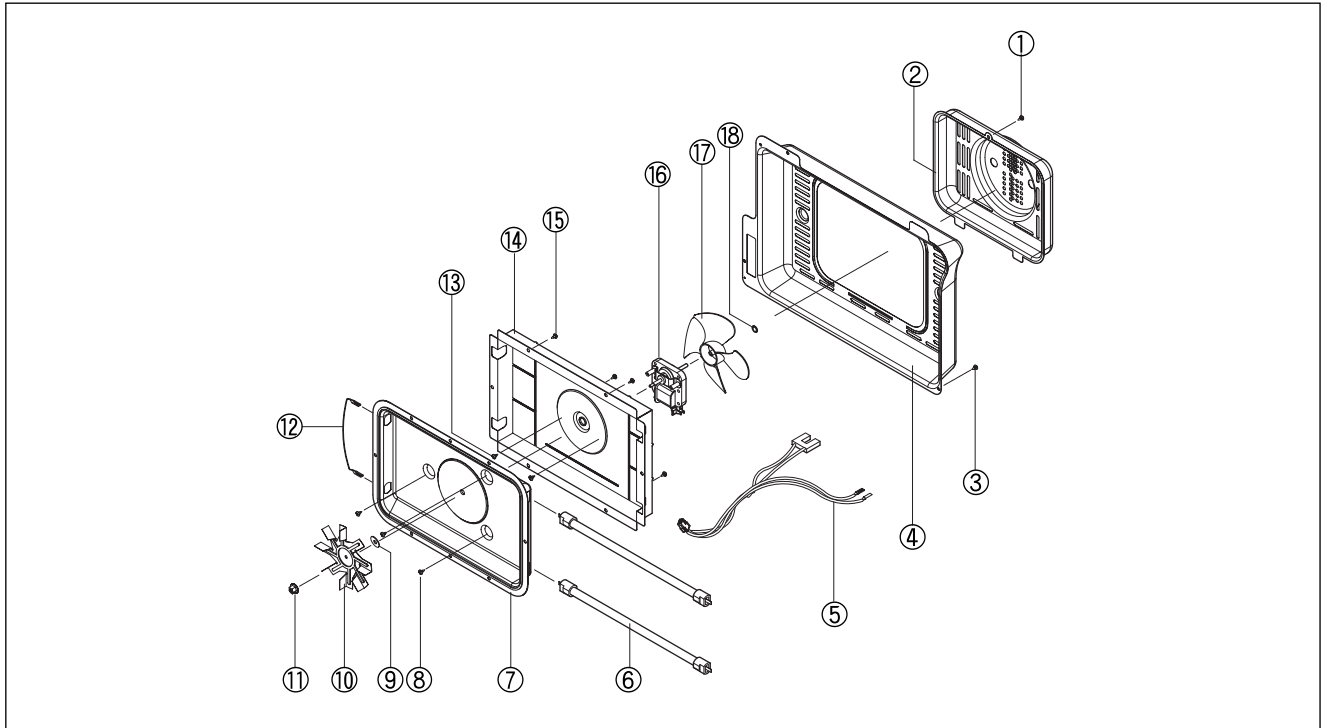

REF NO.	PART CODE	PART NAME	DESCRIPTION	QTY	REMARK
1	7112401011	SCREW TAPPING	T1 TRS 4X10 MFZN	1	
2	3511407300	COVER MOTOR*B	SA1D-80 T0.5	1	
3	7112401011	SCREW TAPPING	T1 TRS 4X10 MFZN	2	
4	3511407400	COVER*B	SA1D-80 T0.5	1	
5	3512766900	HARNES CONVECTION-B	KOC-1B0K0S	1	
6	3512803800	HEATER MIRACLON	115V 550W 270MM	2	
7	3511407700	COVER HEATER*B	SA1D-80 T0.5	1	
8	7113400814	SCREW TAPPING	T1 BIN 4X8 MFNI	3	
9	7400504011	WASHER PLAIN	PW5-5 BRASS	1	
10	3511800700	FAN CONVECTION	SA1D-80 T0.5	1	
11	7S627W50X1	NUT HEX	6N-1-4 BSNI	1	
12	3512766800	HARNES CONVECTION-A	KOC-1B0K0S	1	
13	7051400811	SCREW MACHINE	PAN 4X8 SW MFZN	2	
14	3513302900	INSULATOR HEATER*B	SBHG-1 T0.5	1	
15	7113400814	SCREW TAPPING	T1 BIN 4X8 MFNI	4	
16	3963514300	MOTOR SHADED POLE	230V 50HZ MW10CA-TO	1	
17	3511800800	FAN	PP GF20	1	
18	7402704600	RING-C	CR-5 SK5	1	

- 1) Remove a screw ① and pull out Cover motor \*B②.
- 2) Remove a screw ③ and pull out Cover \*B④.
- 3) Pull out the Harness convection-B⑤.
- 4) Remove four screws ⑮ and then pull out the Rear heater assembly.
- 5) Remove a Nut ⑪ and the pull out the Fan convection ⑩ and Washer plain⑨.
- 6) Remove three screws ⑧ and then separate the Cover heater \*B⑦ and the Insulator heater \*B⑭.
- 7) Pull out two Heaters ⑥ from the Cover Heater \*B⑦.
- 8) Remove two screws ⑬ and then separate the Insulator heater \*B⑭ and Motor shaded pole⑯.
- 9) Remove the C-Ring⑱ and then pull out the Fan ⑰ from Motor shaft.
- 10) Reverse the above steps for reassembly.



✓ **Caution:** In this Service Manual, some parts can be changed for improving, their performance without notice in the parts list. So, if you need the latest parts information, please refer to PPL(Parts Price List) in Service information Center(<http://svc.dwe.co.kr>)

### 13. To remove Motor syncro. And Under heater assembly parts.

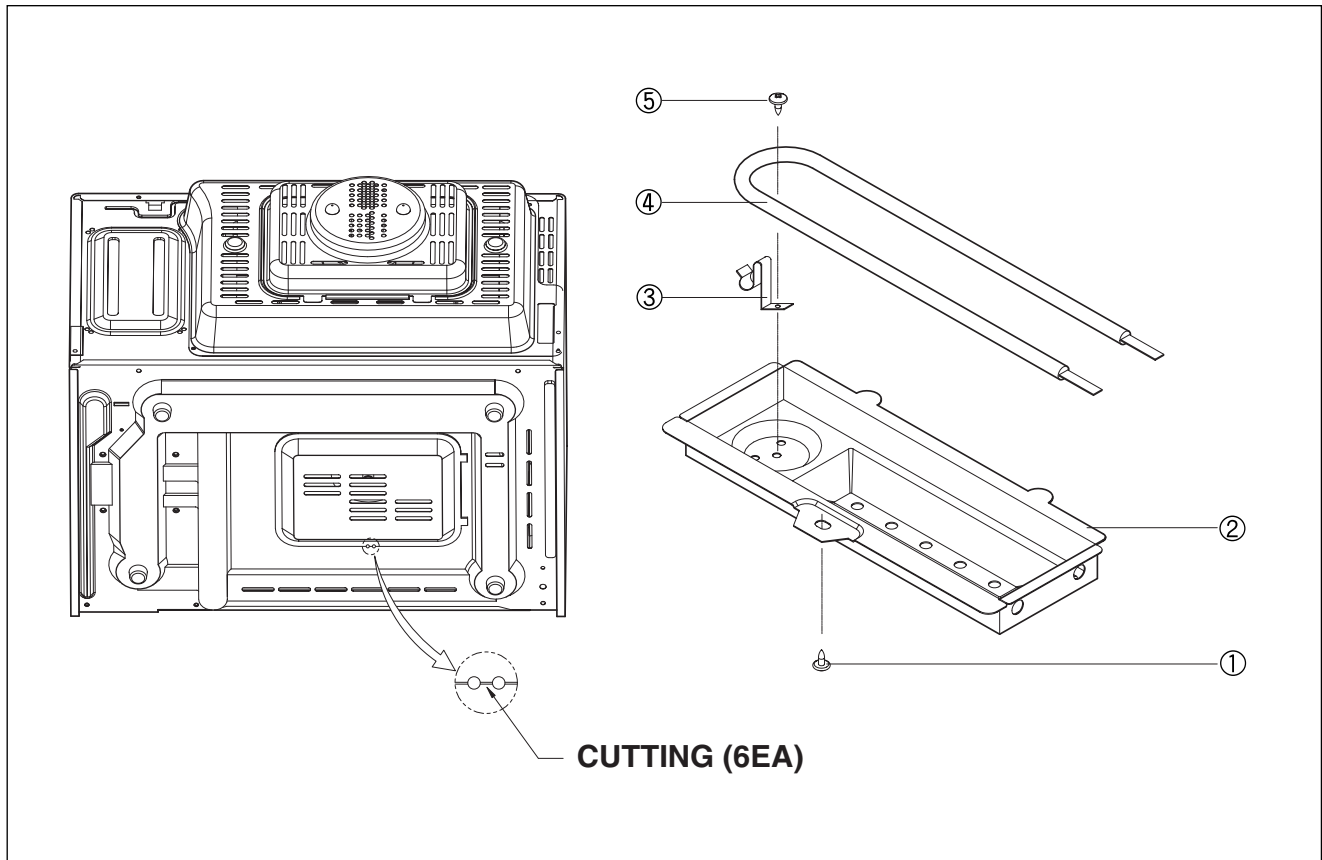

REF NO.	PART CODE	PART NAME	DESCRIPTION	Q TY	REMARK
1	7112401011	SCREW TAPPING	T1 TRS 4X10 MFZN	1	
2	3511407500	COVER HEATER *U	STS430 T0.5	1	
3	3515304000	SUPPORTER HEATER *U	STS430 T0.5	1	
4	3512802000	HEATER *U	230V 400W R18374001	1	
5	7113400814	SCREW TAPPING	T1 BIN 4X8 MFZN	1	

- 1) Cut the Motor syncro. cover parts from the base plate.
- 2) Remove a screw and then pull out Motor syncro.
- 3) Remove a screw ① and then pull out the Under heater \*U. assembly.
- 4) Remove a screw ⑤.
- 5) Pull out the Heater \*U④ from the Cover heater \*U②.
- 6) Reverse the above steps for reassembly.

# 7. INTERLOCK MECHANISM AND ADJUSTMENT

The door lock mechanism is a device which has been specially designed to completely eliminate microwave radiation when the door is opened during operation, and thus to perfectly prevent the danger resulting from the leakage of microwave.

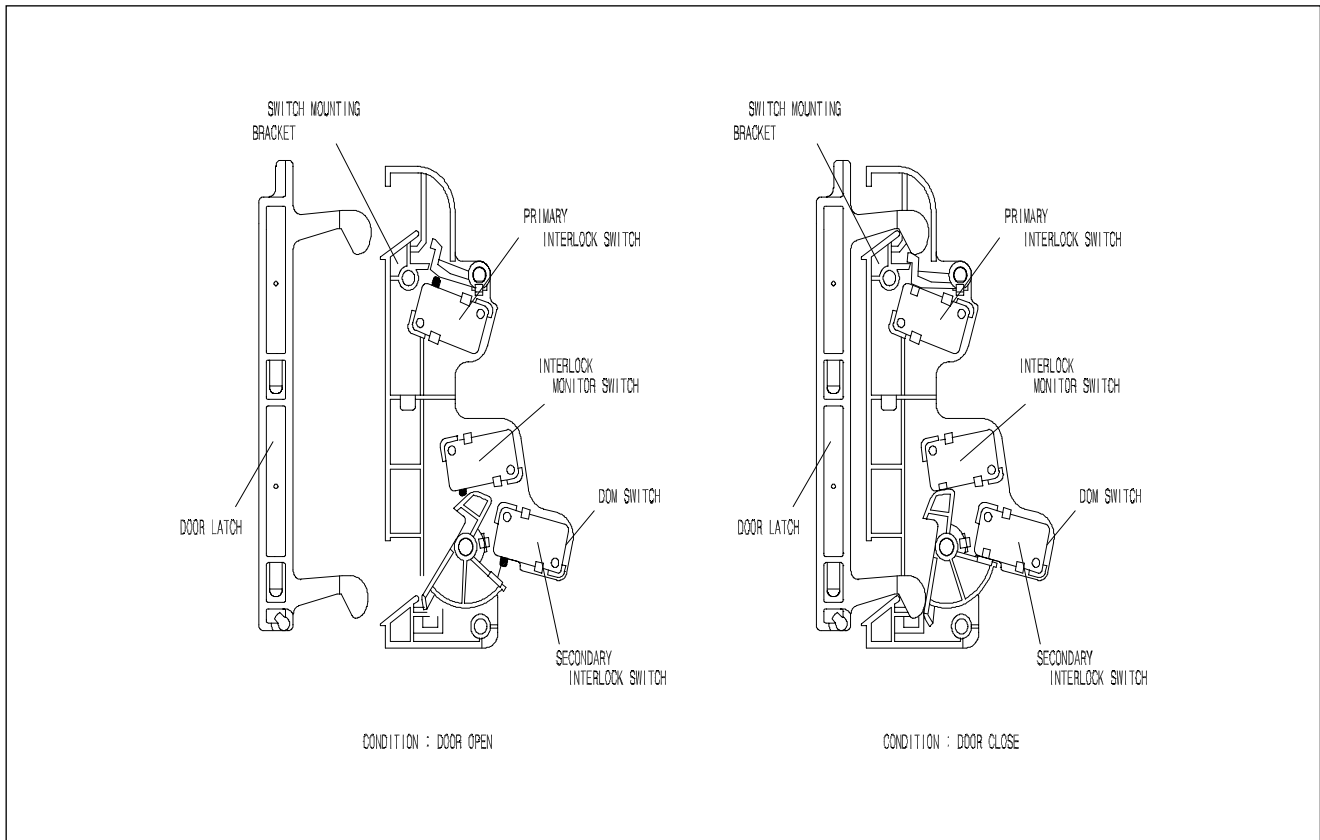

### (1) Primary interlock switch

When the door is closed, the hook locks the oven door. If the door is not closed properly, the oven will not operate.

When the door is closed, the hook pushes the button of the microswitch. Then the button of the primary interlock switch bring it under ON condition.

### (2) Secondary interlock switch and interlock monitor switch

When the door is closed, the hook pushes the lock lever downward. The lock lever presses the button of the interlock monitor switch to bring it under OFF condition and presses the button of the secondary interlock switch to bring it under ON condition.

#### ADJUSTMENT :

Interlock monitor switch

When the door is closed, the interlock monitor switch should be opened before other switches are closed.

When the door is opened, the interlock monitor switch should be closed after other switches are opened.

### (3) Adjustment steps

- Loosen the one mounting screw.
- Adjust interlock switch assembly position.
- Make sure that lock lever moves smoothly after adjustment is completed.
- Tighten completely two mounting screws.

#### NOTE :

Microwave emission test should be performed after adjusting interlock mechanism.

If the microwave emission exceed  $4\text{mW}/\text{cm}^2$ , readjust interlock mechanism.

# 8. TROUBLE SHOOTING GUIDE

Following the procedure below to check if the oven is defective or not.

- 1) Check grounding before trouble checking.
- 2) Be careful of the high voltage circuit.
- 3) Discharge the high voltage capacitor.
- 4) When checking the continuity of the switches, fuse or high voltage transformer, disconnect one load wire from these parts and check continuity with the AC plug removed. To do otherwise may result in a false reading or damage to your meter.

**NOTE :** When electric parts are checked, be sure the power cord is not inserted the wall outlet.  
Check wire harness, wiring and connection of the terminals and power cord before check the parts listed below.

**(TROUBLE 1)** Oven does not operate at all : any inputs can not be accepted.

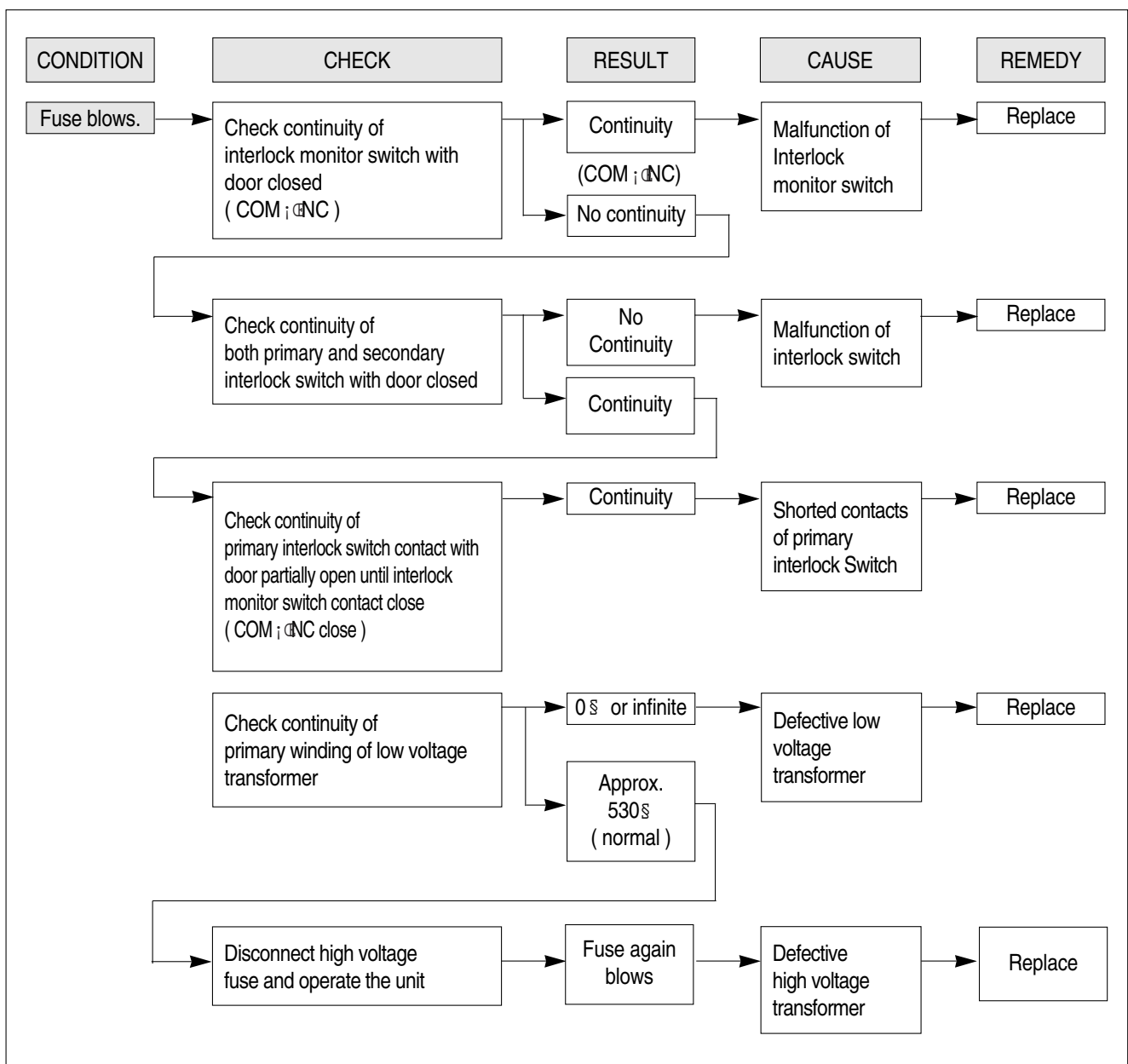

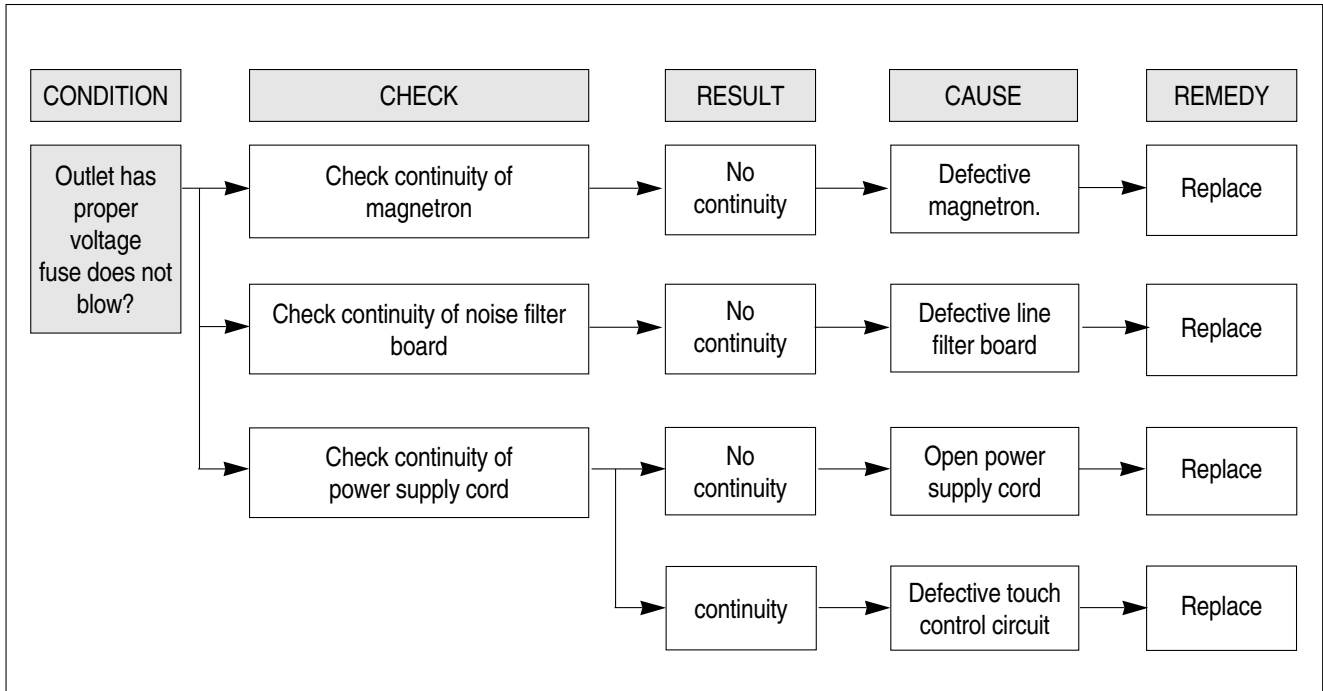

**NOTE : All these switches must be replaced at the same time, please refer to (7.Interlock mechanism and adjust) for adjustment instructions**

**(TROUBLE 2)**

**Display shows all figures selected, but oven does not start cooking, even though desired program and time are set and start button is tapped.**

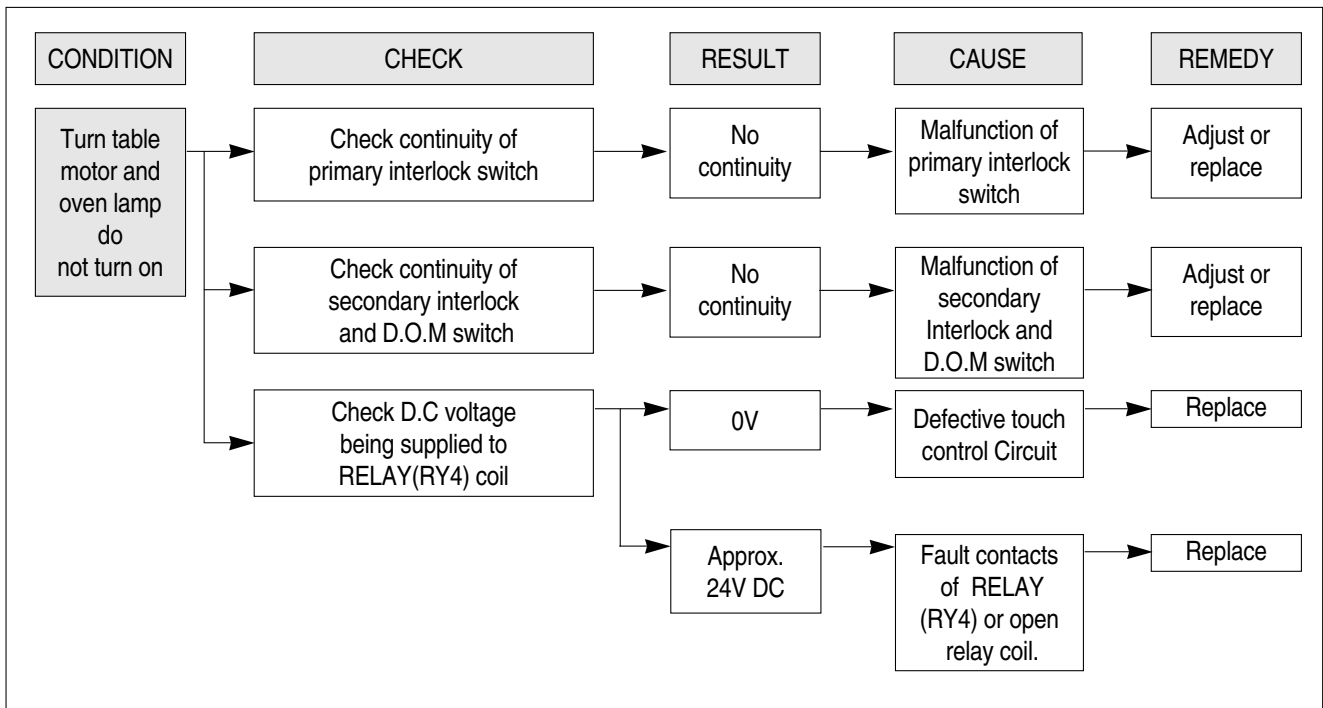

**TROUBLE 3) No microwave oscillation even though fan motor rotates.**

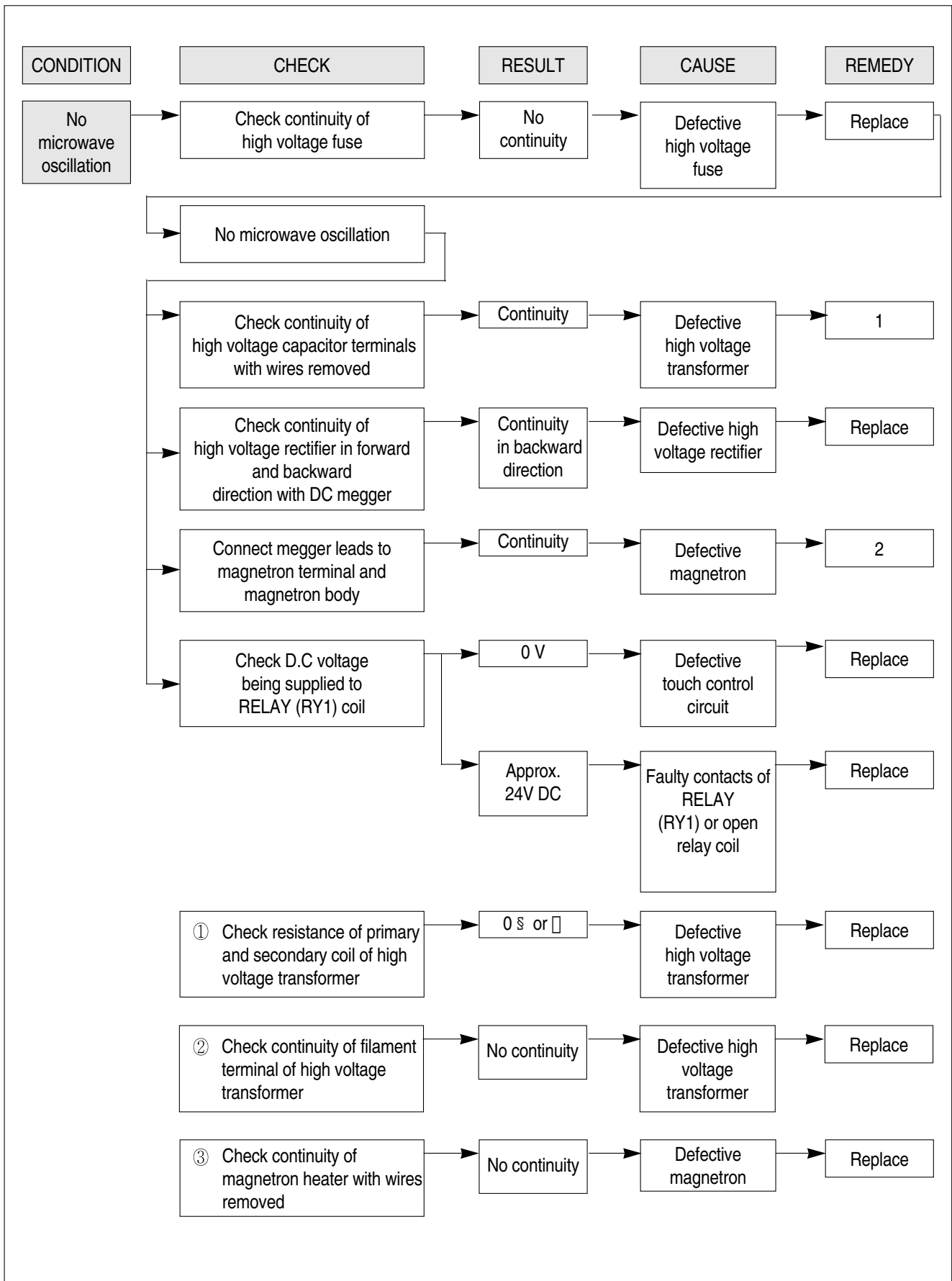

**(TROUBLE 4)**

**Grill heater (upper heater) is not heated; food will not become hot.**

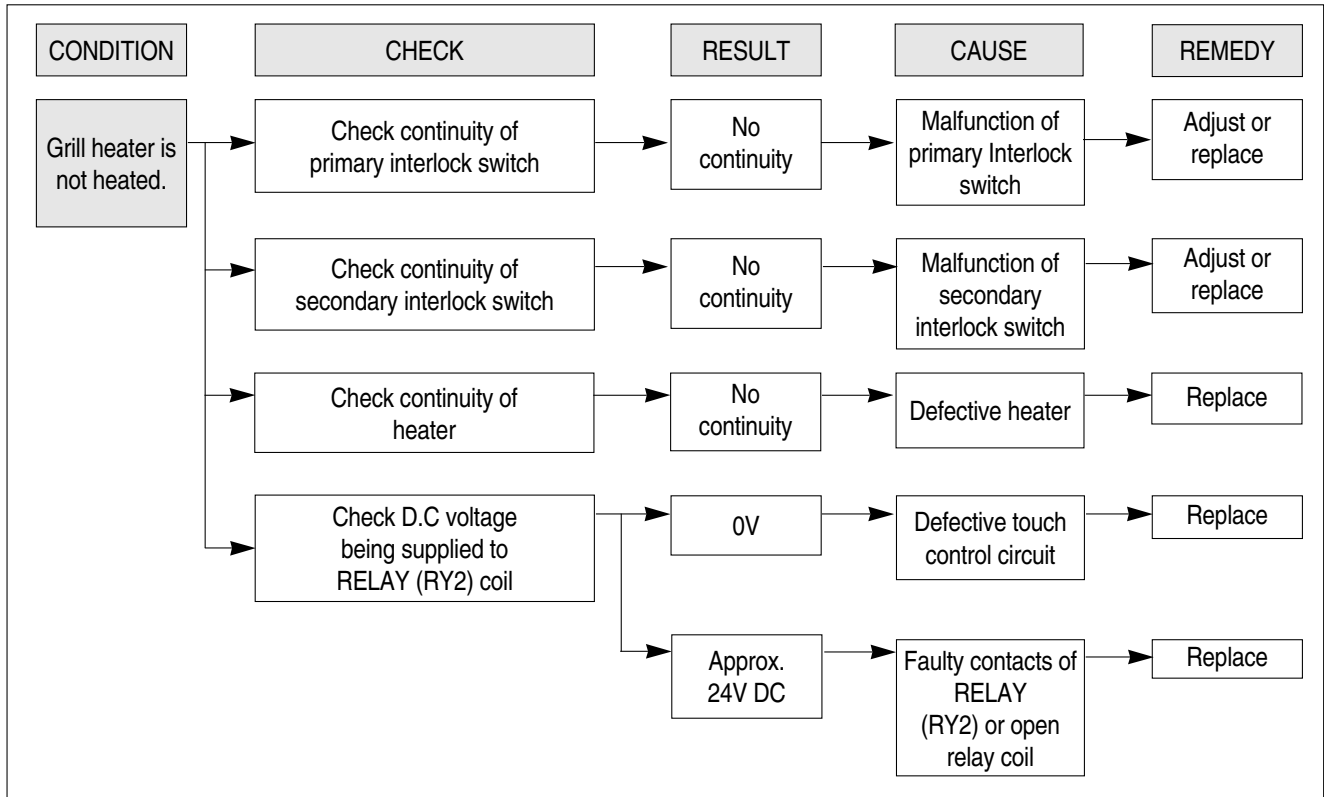

**(TROUBLE 5)**

**1) Convection heater is not heated; food will not become hot.**

**2) Convection fan motor does not rotate.**

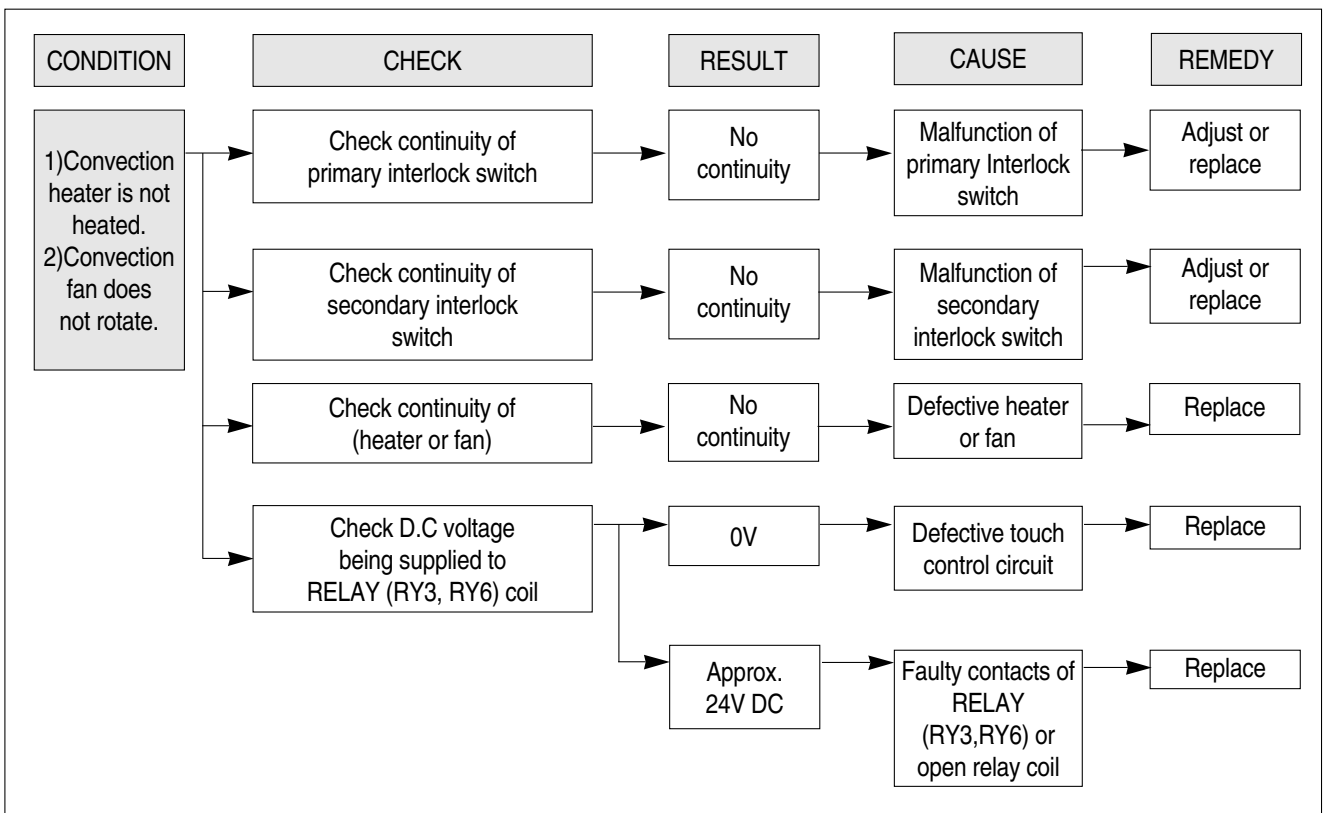

**(TROUBLE 6)**

**Lower heater is not heated; food will not become hot.**

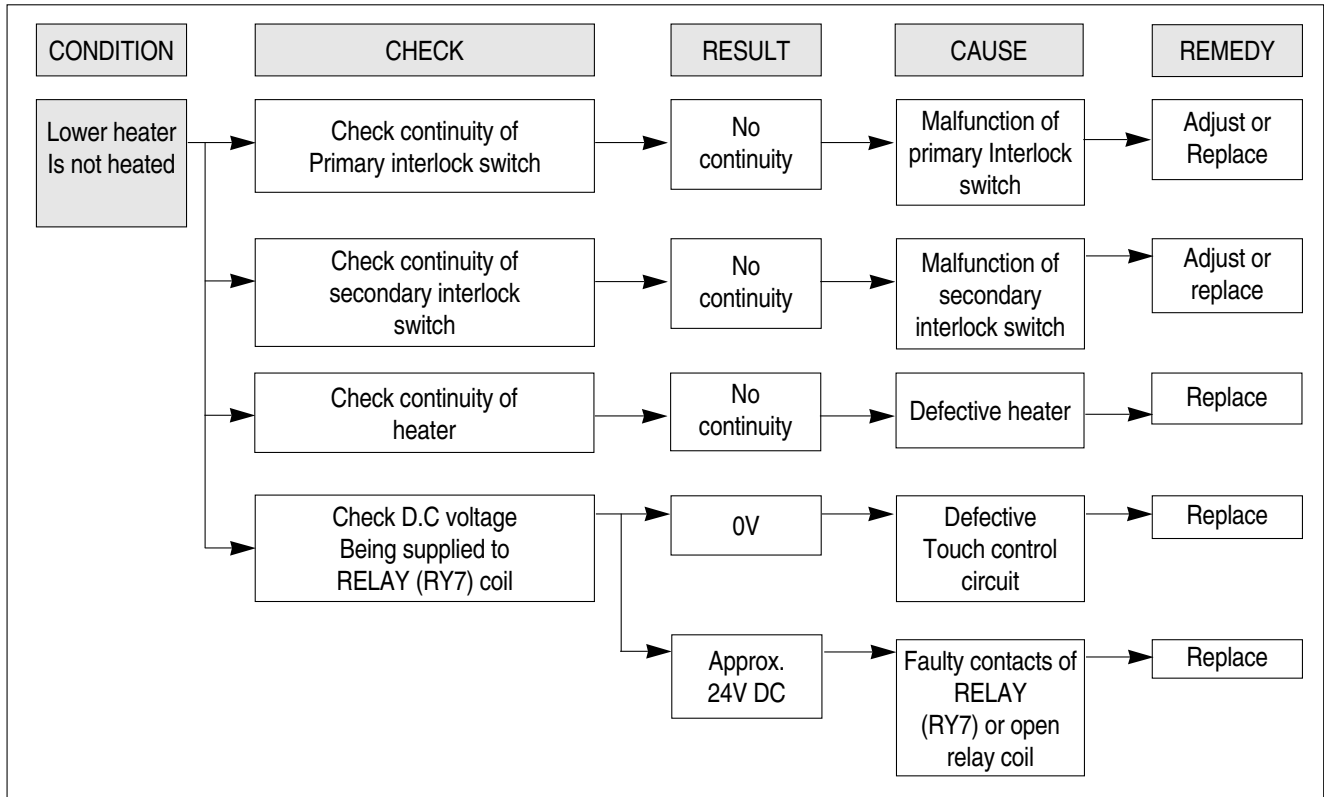

**(TROUBLE 7)**

**The following visual conditions indicate a probable defective touch control Circuit or button P.C.B. assembly**

1. Incomplete segments.
  - 1) segment missing
  - 2) partial segments missing
  - 3) digit flickering other than normal fluorescent slight flickering
2. A distinct change in the brightness of one or more numbers exists in the display
3. One or more digits in the display are not on when they should be.
4. Display does not count down or up with time cooking or clock operation.
5. Oven is programmable and cooks normally but no display shows.
6. Display obviously jumps in time while counting down.
7. Display counts down noticeably too fast while cooking.
8. Display does not show the time of day when clear button is touched.

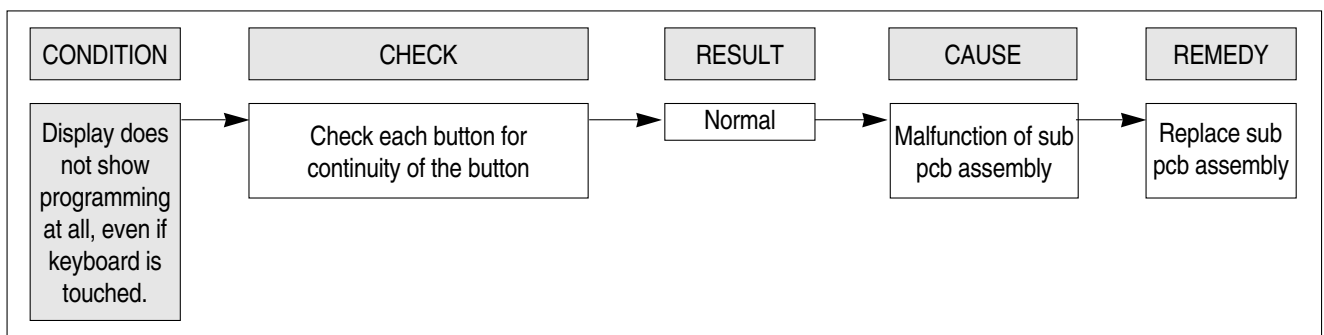
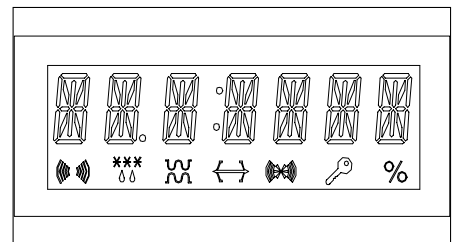

**(TROUBLE 8)**

**When ERROR 2 ERROR 3 come on display.**

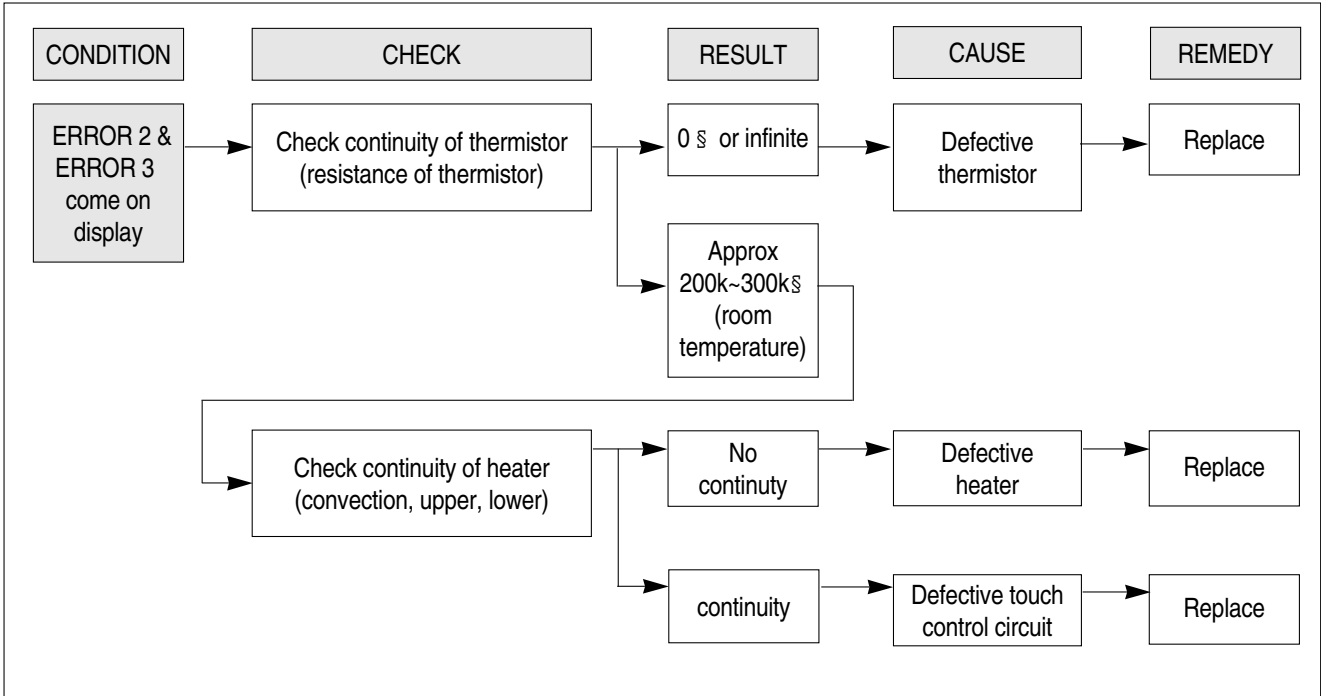



# 9. MEASUREMENT AND TEST

## 1. MEASUREMENT OF THE MICROWAVE POWER OUTPUT

Microwave output power can be checked by indirectly measuring the temperature rise of a certain amount of water exposed to the microwave as directed below.

### PROCEDURE

1. Microwave power output measurement is made with the microwave oven supplied at rated voltage and operated at its maximum microwave power setting with a load of 1000 – 5cc of potable water.
2. The water is contained in a cylindrical borosilicate glass vessel having a maximum material thickness of 3 mm and an outside diameter of approximately 190 mm.
3. The oven and the empty vessel are at ambient temperature prior to the start of the test. The initial temperature of the water is 10 – 2°C (50 – 3.6°F). It is measured immediately before the water is added to the vessel. After addition of the water to the vessel, the load is immediately placed on the center of the shelf, which is in the lowest normal position.
4. Microwave power is switched on.
5. Heating time should be exactly A seconds.  
(Refer to table as following)  
Heating time is measured while the microwave generator is operating at full power. The filament heat-up time for magnetron is not included.
6. The initial and final temperature of water is selected so that the maximum difference between the ambient and final water temperature is 5K.
7. The microwave power output P in watts is calculated from the following formula:

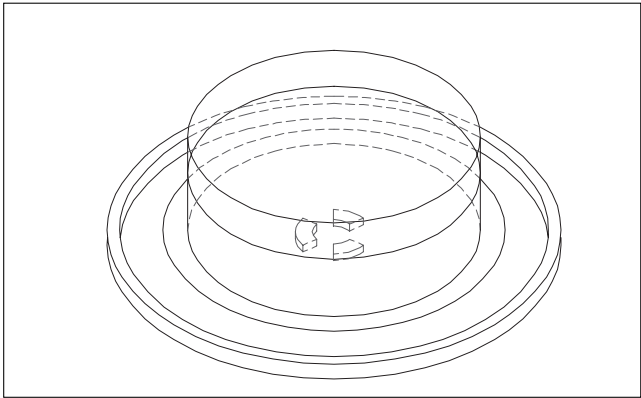

$$P = 4187 \times \Delta T / t$$

¥ΔT is difference between initial and ending temperature.

¥t is the heating time.

The power measured be B (Refer to SPECIFICATIONS) W – 10.0 %.

### CAUTION

1. Water load should be measured exactly to 1 liter.
2. Input power voltage should be exactly specified voltage (Refer to SPECIFICATIONS).
3. Ambient temperature should be 20 – 2°C (68 – 3.6°F)

### \* Heating time for power output:

A (second)	70	64	60	56	52	49	47	44	42	40	38
B (W)	600	650	700	750	800	850	900	950	1000	1050	1100

## 2. MICROWAVE RADIATION TEST

### WARNING

1. Make sure to check the microwave leakage before and after repair of adjustment.
2. Always start measuring of an unknown field to assure safety for operating personnel from microwave energy.
3. Do not place your hands into any suspected microwave radiation field unless the safe density level is known.
4. Care should be taken not to place the eyes in direct line with the source of microwave energy.
5. Slowly approach the unit under test until the radiometer reads an appreciable microwave leakage from the unit under the test.

### PROCEDURE

1. Prepare Microwave Energy Survey Meter, 600cc glass beaker, and glass thermometer 100°C (212°F).
2. Pour 275cc – 15cc of tap water initially at 20 – 5°C (68 – 9°F) in the 600 cc glass beaker with an inside diameter of approx. 95 mm(3.5 in.).
3. Place it at the center of the tray and set it in a cavity.
4. Close the door and operate the oven.
5. Measure the leakage by using Microwave Energy Survey Meter with dual ranges, set to 2450MHz.
  - 1) Measured radiation leakage must not exceed the value prescribed below. Leakage for a fully assembled oven with door normally closed must be less than 4mW/Cm<sup>2</sup>.
  - 2) When measuring the leakage, always use the 5 cm (2 in.) space cone with probe. Hold the probe perpendicular to the cabinet and door. Place the space cone of the probe on the door, cabinet, door seem, door viewing screen, the exhaust air vents and the suction air vents.
  - 3) Measuring should be in a counter-clockwise direction at a rate of 1 in./sec. If the leakage of the cabinet door seem is unknown, move the probe more slowly.
  - 4) When measuring near a corner of the door, keep the probe perpendicular to the areas making sure the probe end at the base of the cone does not get closer than 2 in. from any metal. If it does not, erroneous reading may result.

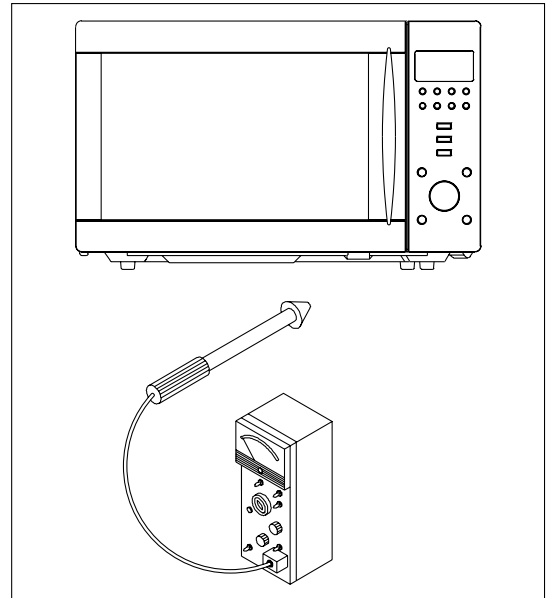

---

### 3. COMPONENT TEST PROCEDURE

¥High voltage is present at the high voltage terminal of the high voltage transformer during any cooking cycle.

¥It is neither necessary nor advisable to attempt measurement of the high voltage.

¥Before touching any oven components or wiring, always unplug the oven from its power source and discharge the capacitor.

#### 1. High voltage transformer

1) Remove connections from the transformer terminals and check continuity.

2) Normal readings should be as follows :

Secondary winding ... Approx. 100 $\Omega$  -10%

Filament winding ... Approx. 0  $\Omega$

Primary winding ... Approx. 1.2  $\Omega$

#### 2. High voltage capacitor

1) Check continuity of capacitor with meter on the highest OHM scale.

2) A normal capacitor will show continuity for a short time, and then indicate 10M $\Omega$  once the capacitor charged.

3) A shorted capacitor will show continuous continuity.

4) An open capacitor will show constant 10M $\Omega$  .

5) Resistance between each terminal and chassis should be infinite.

#### 3. High voltage diode

1) Isolate the diode from the circuit by disconnecting the leads.

2) With the ohmmeter set on the highest resistance scale measure the resistance across the diode terminals.

Reverse the meter leads and again observe the resistance reading. Meter with 6V, 9V or higher voltage batteries should be used to check the front-back resistance of the diode, otherwise an infinite resistance may be read in both directions. A normal diode's resistance will be infinite in one direction and several hundred k $\Omega$  in the other direction.

#### 4. Magnetron

For complete magnetron diagnosis, refer to "Measurement of the Microwave Power Output." Continuity checks can only indicate an open filament or a shorted magnetron. To diagnose for an open filament or a shorted magnetron,

1) Isolate magnetron from the circuit by disconnecting the leads.

2) A continuity check across magnetron filament terminals should indicate 0.1  $\Omega$  or less.

3) A continuity check between each filament terminal and magnetron case should read open.

#### 5. Fuse

If the fuse in the primary and monitor switch circuit is blown when the door is opened, check the primary and monitor switch before replacing the blown fuse. In case the fuse is blown by an improper switch operation, replace the defective switch and fuse at the same time. Replace just the fuse if the switches operate normally.

#### 4. COMPONENT ACTION

COOKING MODE		MAGNE- TRON	UPPER ELEMENT	LOWER ELEMENT	REAR ELEMENT	CONVEC- TION FAN
MANUAL MODE	M/W	●				
	GRILL-1		●			
	GRILL-2			●		
	GRILL-3		●	●		
	COMBI-1	●	●	●	●	●
	COMBI-2	●	●	●	●	●
	COMBI-3		●	●	●	●
	COMBI-4	●	●			
	COMBI-5	●	●	●		
	CONVECTION100~130				●	●
	CONVECTION140~150			●	●	●
	CONVECTION160~250		●	●	●	●
ONE TOUCH	CAKE/BREAD	●	●	●	●	●
	CRUSTY	●	●	●	●	●
AUTO MODE	ROAST BEEF	●	●	●	●	●
	ROAST CHICKEN	●	●	●	●	●
	ROAST PORK	●	●	●	●	●
	BAKED FISH	●	●	●	●	●
	BAKED POTATO	●	●	●	●	●
	ROAST POTATO	●	●	●	●	●
	FRESH VEGETABLES	●				
	FROZEN VEGETABLES	●				
	CASSEROLE	●				

# 10. WIRING DIAGRAM

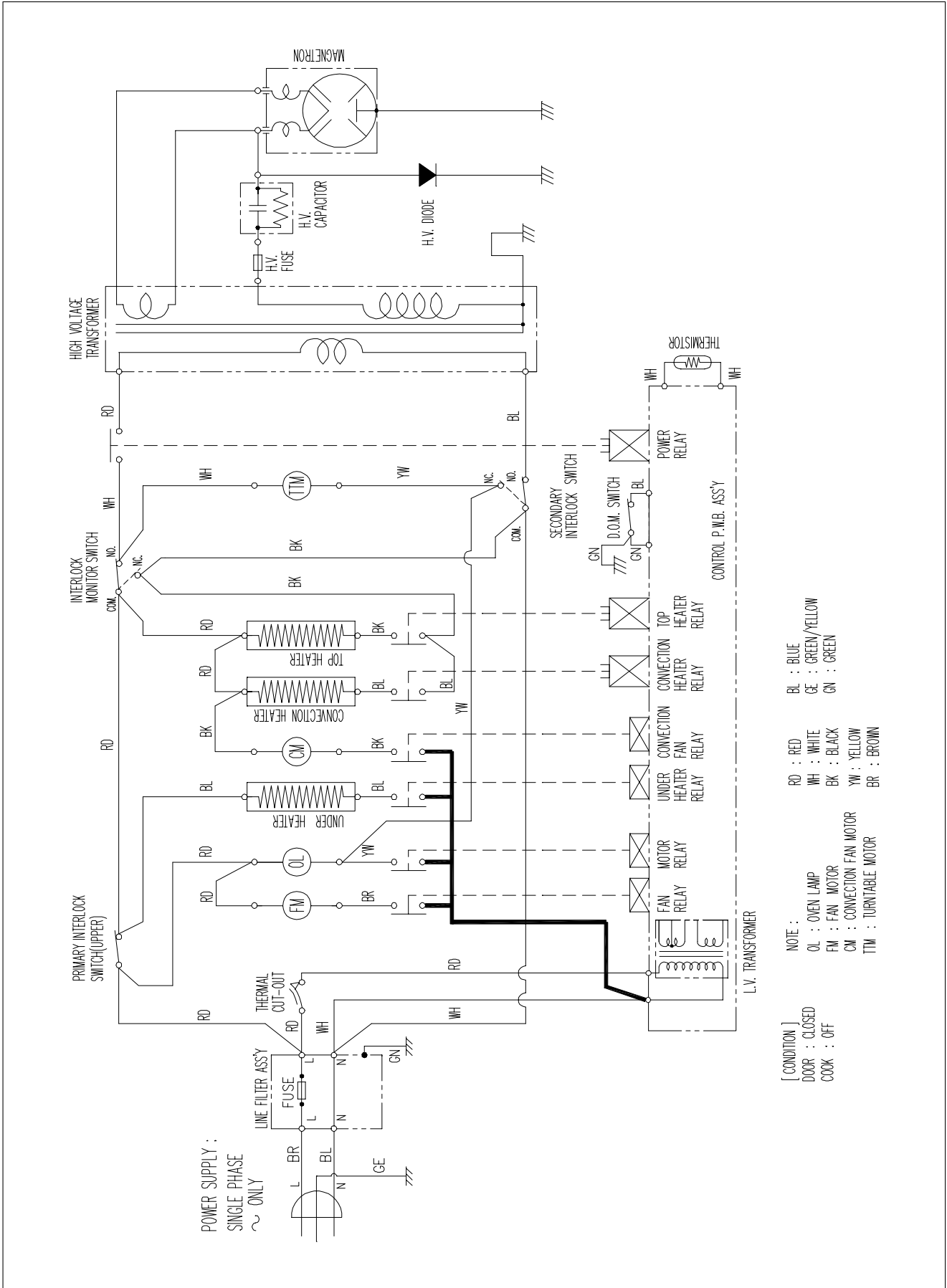

# 11. EXPLODED VIEW AND PARTS LIST

## 1. DOOR ASSEMBLY

Refer to 6. Disassembly and assembly.

## 2. CONTROL PANEL ASSEMBLY

Refer to 6. Disassembly and assembly.

## 3. TOTAL ASSEMBLY

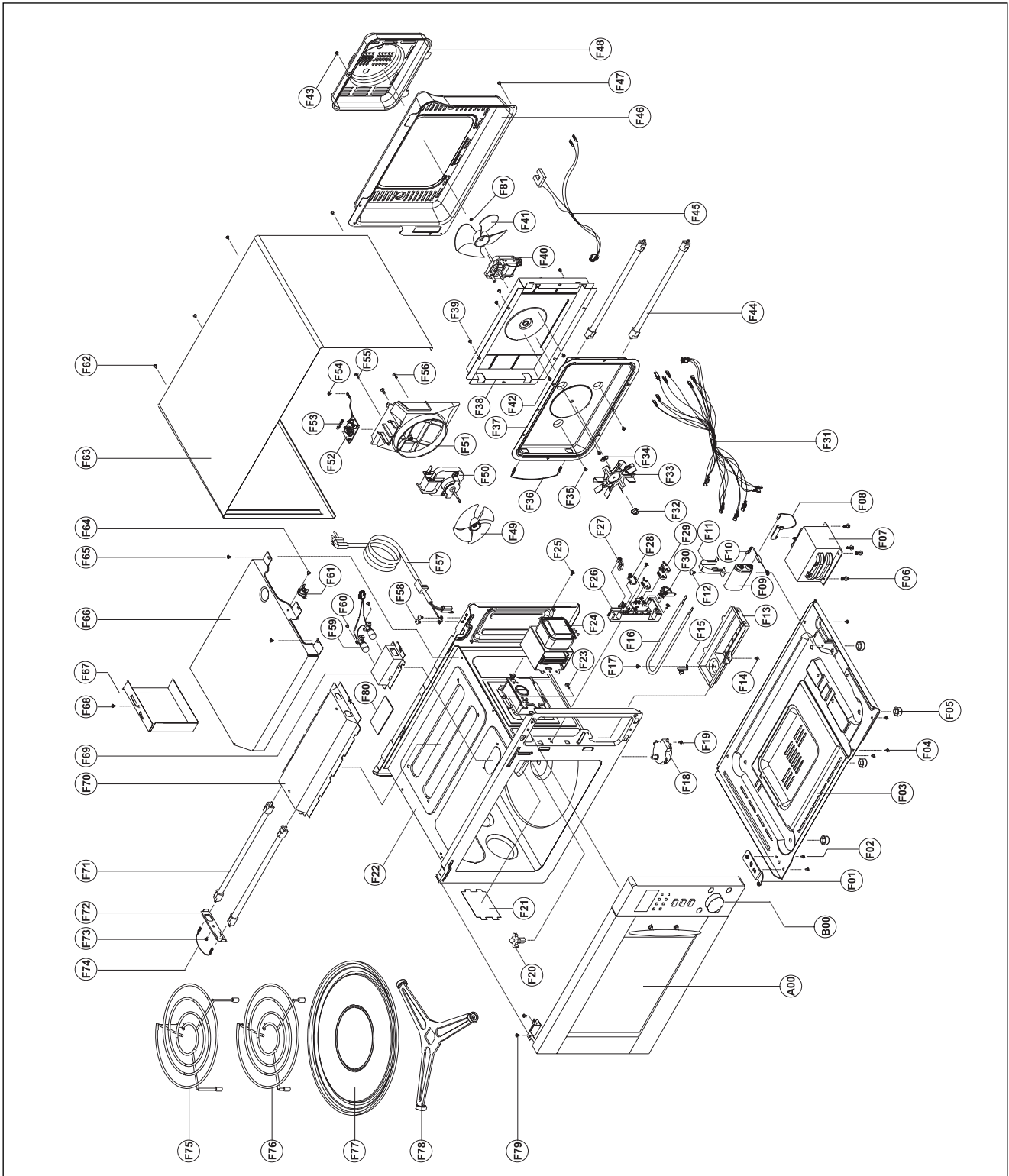

✓ **Caution:** In this Service Manual, some parts can be changed for improving, their performance without notice in the parts list. So, if you need the latest parts information, please refer to PPL(Parts Price List) in Service information Center(<http://svc.dwe.co.kr>)

NO	PART CODE	PART NAME	DESCRIPTION	Q'TY
A00	3511714040	DOOR AS	KOC-1B4K0S	1
B00	PKCPSWAD00	CONTROL PANEL AS	KOC-1B4K0S	1
	PKCPSWAD20		KOC-1B4K5S	1
F01	3515202200	STOPPER HINGE *U AS	KOR-121M0A	1
F02	7272400800	SCREW TAPTITE	TT3 TRS 4X8 MFZN	1
F03	3510313500	BASE	SBHG T0.8	1
F04	7112401011	SCREW TAPPING	T1 TRS 4X10 MFZN	5
F05	3512101400	FOOT	DASF-310	4
F06	3516003700	SPECIAL SCREW	TT3 HEX 4X8 FLG MFZN	4
F07	3518117010	TRANS HV	DW-N95S0-1BT	1
F08	3518701400	FUSE HV	5KV 0.7A	1
F09	3518302300	CAPACITOR HV	2100VAC 1.10UF #187	1
F10	3518400400	DIODE HV	HVR-1X-3AB 12KV #187	1
F11	3513003200	HOLDER HV CAPAITOR	SECC T0.6	1
F12	7272400811	SCREW TAPTITE	TT3 TRS 4X8 MFZN	1
F13	3511407500	COVER HEATER *U	STS430 T0.5	1
F14	7112401011	SCREW TAPPING	T1 TRS 4X10 MFZN	1
F15	3515304000	SUPPORET HEATER *U	STS 430 T0.5	1
F16	3512802000	HEATER *U	230V 400W R18374001	1
F17	7113400814	SCREW TAPPING	T1 RIN 4X8 MFZN	1
F18	3966510200	MOTOR SYNCRO	230V 25W GM-16-24FD24	1
F19	7112401011	SCREW TAPPING	T1 TRS 4X10MFZN	1
F20	3517401900	COUPLER	PTFE	1
F21	3511408300	COVER WAVE GUIDE	MICA T0.35	1
F22	3516111300	CAVITY JOINT AS	CAVITY JOINT AS	1
F23	7122401211	SCREW TAPPING	T2S TRS 4X12 MFZN	1
F24	3518002900	MAGNETRON	2M218H(F)P	1
F25	3516004000	SPECIAL SCREW	TS BOLT FLANGE 5X12 DACRO	1
F26	3513804700	LOCK	POM	1
F27	3513702100	LEVER SW MICRO	POM KOG-846TOS	1
F28	4415A17352	SW MICRO	VP-533A-0F SPNO #187 200G	2
F29	4415A66910	SW MICRO	VP-531A-0F/SZM-V16-FA-61	2
F30	3513700800	LEVER LOCK	POM	1
F31	3512717700	HARNESS MAIN	KOC-1B0K0S	1
F32	7S627W50X1	NUT HEX	6N-1-4 BSNI	1
F33	3511800700	FAN CONVECTION	SA1D T0.5	1
F34	7400504011	WASHER PLAIN	PW-5-5-MFZN	1

✓ **Caution:** In this Service Manual, some parts can be changed for improving, their performance without notice in the parts list. So, if you need the latest parts information, please refer to PPL(Parts Price List) in Service information Center(<http://svc.dwe.co.kr>)

NO	PART CODE	PART NAME	DESCRIPTION	Q'TY
F35	7113400814	SCREW TAPPING	T1 BIN 4X8 MFNI	3
F36	3512766800	HARNESS CONVECTION-A	KOC-1B0K0S	1
F37	3511407700	COVER HEATER *B	SA1D-80 T0.5	1
F38	3513302900	INSULATOR HEATER *B	SBHG-1 T0.5	1
F39	7113400814	SCREW TAPPING	T1 BIN 4X8 MFNI	4
F40	3963514300	MOTOR SHADED POLE	230V 50HZ MW10CA-T02	1
F41	3511800800	FAN PP	GF20	1
F42	7051400811	SCREW MACHINE	PAN 4X8 SW MFZN	2
F43	7112401011	SCREW TAPPING	T1 TRS 4X10MFZN	1
F44	3512803800	HEATER MIRACLON	115V 550W 270MM	2
F45	3512766900	HARNESS CONVECTION-B	KOC-1B0K0S	1
F46	3511407400	COVER *B	SA1D-80 T0.5	1
F47	7112401011	SCREW TAPPING	T1 TRS 4X10MFZN	1
F48	3511407300	COVER MOTOR *B	SA1D-80 T0.5	1
F49	3511800100	FAN	PP GF20	1
F50	3963513000	MOTOR SHADED POLE	230V 25W OEM-15DWC2-A03	1
F51	3512515300	GUIDE WIND	PP GF20	1
F52	3518605001	NOISE FILTER	DWLF-M05	1
	3518605500		DWLF-M07	1
F53	3513003900	FUSE HV		1
F54	7112401011	SCREW TAPPING	T1 TRS 4X10 MFZN	1
F55	7122401211	SCREW TAPPING	T2S TRS 4X12 MFZN	1
F56	7121403011	SCREW TAPPING	T2S PAN 4X30 MFZN	2
F57	35113A5QJ5	CORD POWER AS	3X1.5 80X80 120-RTML 1.4M	1
	35113A5QM5		3X1.0 80X80 120-RTML 1.4M	1
F58	7112401011	SCREW TAPPING	T1 TRS 4X10 MFZN	2
F59	3513602600	LAMP	HALOGEN	2
F60	7112401011	SCREW TAPPING	T1 TRS 4X10 MFZN	2
F61	3518906100	THERMOSTAT	OFF:90 ON:60 V#187	1
F62	7S312X40A1	SCREW TAPPING	T1 TRS 4X10 MFZN	4
F63	3510803300	CABINET	SECC T0.5	1
F64	7121400611	SCREW TAPPING	T2S PAN 4X6 MFZN	1
F65	7112401011	SCREW TAPPING	T1 TRS 4X10 MFZN	2
F66	3513302800	INSULATOR HEATER *T	SECC T0.5	1
F67	3512520500	GUIDE AIR OUTLET	SA1D-80 T0.5	1
F68	7112401011	SCREW TAPPING	T1 TRS 4X10 MFZN	1
F69	3511407800	COVER LAMP	STS430 T0.5	1



✓ **Caution:** In this Service Manual, some parts can be changed for improving, their performance without notice in the parts list. So, if you need the latest parts information, please refer to PPL(Parts Price List) in Service information Center(<http://svc.dwe.co.kr>)

NO	PART CODE	PART NAME	DESCRIPTION	Q'TY
F70	3511407600	COVER HEATER *T	STS430 T0.5	1
F71	3512803800	HEATER MIRACLON	115V 550W 270MM	2
F72	3510607700	BRACKET HEATER *T	SA1D T0.5	1
F73	7112401411	SCREW TAPPING	T1 TRS 4X10 MFZN	1
F74	3512767000	HARNESS HEATER	KOC-1B0K0S	1
F75	3517207300	TRAY RACK AS	KOC-1B0K0S 120MM	1
F76	3517207310	TRAY RACK AS	KOC-1B0K0S 30MM	1
F77	3517207200	TRAY METAL	SPP T0.6	1
F78	3512521000	GUIDE ROLLER AS	KOC-1B0K0S	1
F79	3516003700	SPECIAL SCREW	TT3 HEX 4X8 FLG MFZN	1
F80	3511407810	COVER LAMP	T/GLASS T2.0	1
F81	7402704600	RING C	CR-5 SK5	1

# 12. PRINTED CIRCUIT BOARD

## CIRCUIT CHECK PROCEDURE

### 1. Low voltage transformer check

The low voltage transformer is located on the P.C.B.

Measuring condition: Input voltage: 120V / Frequency: 60Hz

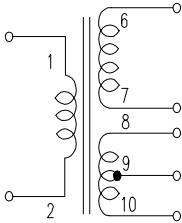

Terminal	Voltage(olad)	Voltage(no load)
6-7	AC 17.0 V	AC 19.9 V
8-9	AC 1.3 V	AC 1.6 V
9-10	AC 1.3 V	AC 1.6 V

#### NOTE

1. Secondary side voltage of the low voltage transformer changes in proportion to fluctuation of power source voltage.
2. The allowable tolerance of the secondary voltage is within – 5% of nominal voltage.

### 2. Voltage Check

- Key check point

NO	CHECK POINT	REMARK
1	IC1 PIN 63, 64	5VDC-5%
2	IC1 PIN 38	<p>T : 20 ms(50Hz)</p>
3	IC1 PIN 33 OR 34	<p>T : 250 ns(4MHz)</p>

- Check method

NO	MEASURE POINT	WAVE FORM	REMEDY	REMARK
1	A	DC 5V-5%	Replace ZD2, EC1	NO LOAD
2	B	DC 24V-20%	Replace D20-23, EC6	NO LOAD

**NOTE:** Each measure point must be measured with GND points.

: The marks of the above corresponding voltage (+5V, +24V) are written on the PCB.

**3. Case of no microwave oscillation**

1) When touching M/W button, oven lamp turns on and Fan motor and turntable rotate, and cook indicator in display comes on.

\*Cause: **RELAY 1** does not operate.

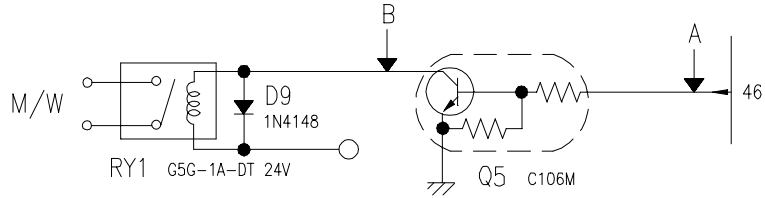

STATE	POINT A	POINT B
<b>RELAY 1 ON</b>	+5V DC	GND
<b>RELAY 1 OFF</b>	GND	+24V DC

2) When touching M/W button, oven lamp does not turn on and turntable motor does not rotate but cook indicator in display comes on.

\*Cause: **RELAY 1** does not operate.

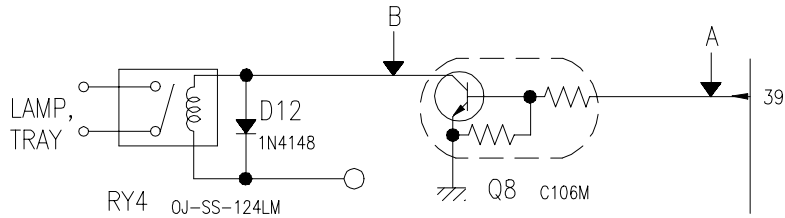

STATE	POINT A	POINT B
<b>RELAY 4 ON</b>	+5V DC	GND
<b>RELAY 4 OFF</b>	GND	+24V DC

3) When touching M/W button, oven lamp turn on and turns on and fan motor does not rotate but cook indicator in display comes on.

\*Cause: **RELAY 5** does not operate.

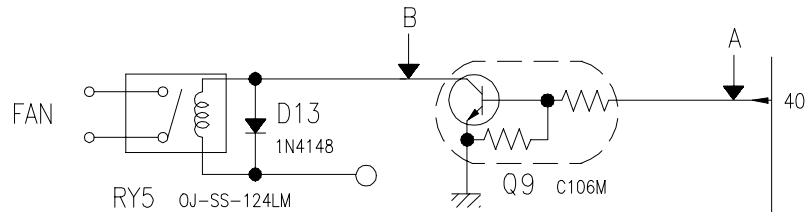

STATE	POINT A	POINT B
<b>RELAY 5 ON</b>	+5V DC	GND
<b>RELAY 5 OFF</b>	GND	+24V DC

#### 4. Case of no heating of upper grill

When touching GRILL1 & COMBI button, oven lamp turns on and Fan motor and turntable rotate, and cook indicator in display comes on.

\*Cause: **RELAY 2** does not operate.

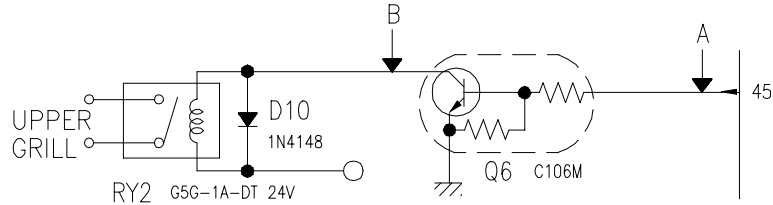

STATE	POINT A	POINT B
<b>RELAY 2 ON</b>	+5V DC	GND
<b>RELAY 2 OFF</b>	GND	+24V DC

#### 5. Case of no heating of lower grill

When touching GRILL2 & COMBI button, oven lamp turns on and Fan motor and turntable rotate and cook indicator in display comes on.

\*Cause: **RELAY 7** does not operate.

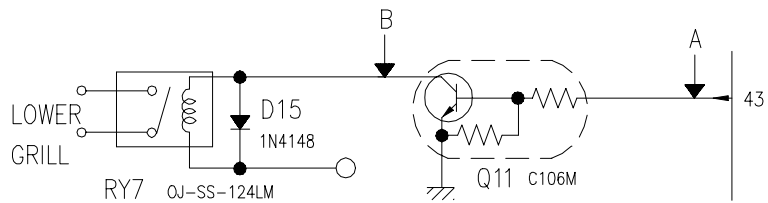

STATE	POINT A	POINT B
<b>RELAY 7 ON</b>	+5V DC	GND
<b>RELAY 7 OFF</b>	GND	+24V DC

#### 6. Case of no heating of convection grill

When touching CONVECTION button, oven lamp turns on and Fan motor and turntable rotate and cook indicator in display comes on.

\*Cause: **RELAY 3** does not operate.

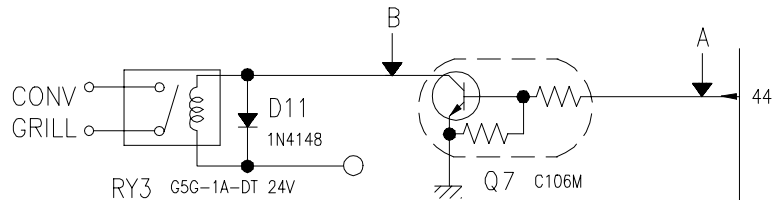

STATE	POINT A	POINT B
<b>RELAY 3 ON</b>	+5V DC	GND
<b>RELAY 3 OFF</b>	GND	+24V DC

## 7. Case of no stopping of the count down timer

When the door is opened during operation, the count down timer does not stop.

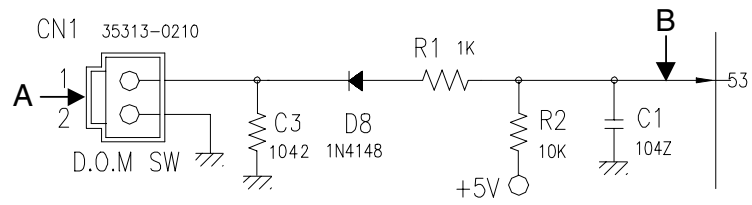

STATE \ POINT	A	B
<b>DOOR OPEN</b>	OPEN	+5V DC
<b>DOOR CLOSED</b>	CLOSE	GND

CHECK NO	METHOD	REMEDY
<b>1</b>	Check the stage(ON,OFF) of the door open monitor switch by resistance measurement.	Replace door open monitor switch.

# 13. P.C.B. CIRCUIT DIAGRAM

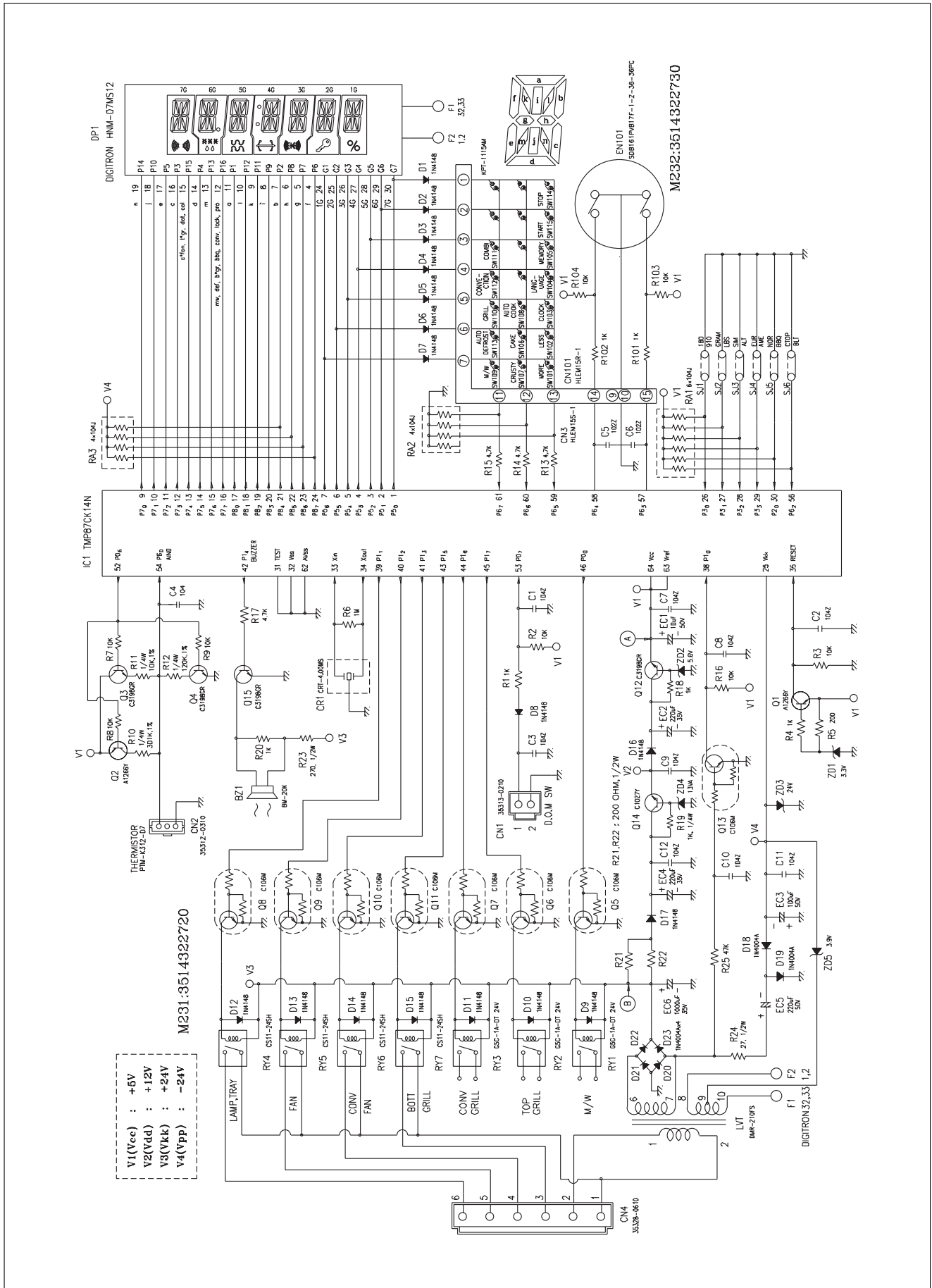

✓ **Caution:** In this Service Manual, some parts can be changed for improving, their performance without notice in the parts list. So, if you need the latest parts information, please refer to PPL(Parts Price List) in Service information Center(<http://svc.dwe.co.kr>)

## PCB ASS Y PART LIST

NO	NAME	SYMBOL	SPECIFICATION	PART CODE	Q'TY
1	PCB MAIN	M231	95.5 X 197	3514322720	1
2	PCB SUB	M232	88 X 197	3514322730	1
3	BUZZER	BZ1	BM-20K	3515600100	1
4	CAPACITOR CERAMIC	C1~C4,C7~C12	104 50V Z AXIAL	CCZF1H104Z	10
5	CAPACITOR CERAMIC	C5,C6	102 50V Z AXIAL	CCZB1H102K	2
6	CAPACITOR ELECTRO	EC1	50V RS 10uF	CEXE1H100A	1
7	CAPACITOR ELECTRO	EC2,EC4	35V RSS 220uF	CEXF1V221V	2
8	CAPACITOR ELECTRO	EC6	35V RSS 1000uF	CEXF1V102V	1
9	CAPACITOR ELECTRO	EC5	50V RSS 220uF	CEXF1H221V	1
10	CAPACITOR ELECTRO	EC3	50V RSS 100uF	CEXF1H101V	1
11	CONNECTOR FILM	CN3	HLEM15S-1	4CW215SBD0	1
12	CONNECTOR WAFER	CN1	35313-0210	30166M7020	1
13	CONNECTOR WAFER	CN2	35312-0310	30166M5030	1
14	CONNECTOR WAFER	CN4	35328-0610	4CW3061MX0	1
15	DIODE SWITCHING	D1~D17	1N4148 AUTO 52mm	DZN4148---	17
16	DIODE RECTIFYING	D18~D23	1N4004A AUTO 52mm	DZN4004A--	6
17	DIODE ZENER	ZD1	UZ -3.3BSB	DZUZ3R3BSB	1
18	DIODE ZENER	ZD5	UZ -3.9BSB	DZUZ3R9BSB	1
19	DIODE ZENER	ZD2	UZ -5.6BSB	DZUZ5R6BSB	1
20	DIODE ZENER	ZD4	UZ -13BSA	DZUZ13BSA-	1
21	DIODE ZENER	ZD3	UZ -24BSB	DZUZ24BSB-	1
22	DIGITRON	DP1	HNM-07MS12	DHNM07MS12	1
23	HOLDER VFD	DPH	NYLON 66	3513002000	1
24	IC MICOM	IC1	TMP87CK14N-2B01	13GS1B1K00	1
25	RESISTOR	R2,R3,R7~R9,R16	1/6W 10K Ohm 5%	RD-AZ103J-	6
26	RESISTOR	R1,R4,R18,R20	1/6W 1K Ohm 5%	RD-AZ102J-	4
27	RESISTOR	R5	1/6W 200 Ohm 5%	RD-AZ201J-	1
28	RESISTOR	R6	1/6W 1M Ohm 5%	RD-AZ105J-	1
29	RESISTOR	R13~R15,R17	1/6W 4.7K Ohm 5%	RD-AZ472J-	4
30	RESISTOR	R25	1/6W 47K Ohm 5%	RD-AZ473J-	1
31	RESISTOR	R19	1/4W 1K Ohm 5%	RD-4Z102J-	1
32	RESISTOR	R23	1/2W 270 Ohm 5%	RD-2Z271JS	1
33	RESISTOR	R24	1/2W 27 Ohm 5%	RD-2Z270JS	1
34	RESISTOR	R21,R22	1/2W 200 Ohm 5%	RD-2Z201JS	2
35	RESISTOR	R10	1/4W 301K Ohm 1%	RN-4Z3013F	1
36	RESISTOR	R11	1/4W 10K Ohm 1%	RN-4Z1002F	1
37	RESISTOR	R12	1/4W 120K Ohm 1%	RN-4Z1203F	1
38	RESISTOR ARRAY	RA1	7P(6) 1/8 100K 5%	RA-87X104J	1
39	RESISTOR ARRAY	RA2,RA3	5P(4) 1/8 100K 5%	RA-85X104J	2
40	RESONATOR CERAMIC	CR1	CRT-4.00MS	5P4R00MTS-	1
41	SW RELAY	RY1	G5G-1A-DT 24V	5SC0101124	1
42	SW RELAY	RY2,RY3	G5G-1A-DT 24V	5SC0101124	2
		"	(OZF-S-124LM1P)	5SC0101117	2
43	SW RELAY	RY4~RY7	CS11-24SH	5SC0101129	4
44	TRANSISTOR	Q1,Q2	KTA1266Y AUTO	TZTA1266Y-	2
45	TRANSISTOR	Q3,Q4,Q12,Q15	KTC3198GR AUTO	TZTC3198GR	4
46	TRANSISTOR	Q14	KTC-1027Y AUTO	TZTC1027Y-	1
47	TRANSISTOR	Q5~Q11,Q13	KRC106M AUTO	TZRC106M--	8
48	TRANS POWER	LVT1	DMR-210FS	5EPV041410	1
49	WIRE COPPER 20mm	J2	1/0.52 TIN COATING	85801052GY	1
50	WIRE COPPER 12.5mm	J3~J7	1/0.52 TIN COATING	85801052GY	5
51	WIRE COPPER 10mm	J1,J8,J9,J16	1/0.52 TIN COATING	85801052GY	4
52	WIRE COPPER 7.5mm	J10~J15	1/0.52 TIN COATING	85801052GY	6
53	CONNECTOR WAFER	CN101	HLEM15R-1	4CW215RBD0	1
54	RESISTOR	R101,R102	1/6W 1K Ohm 5%	RD-AZ102J-	2
55	RESISTOR	R103,R104	1/6W 10K Ohm 5%	RD-AZ103J-	2
56	SW ROTARY	EN101	SDB161PVB17F-1-2-36-36PC(PITCH5)	5S10109002	1
57	SW TACT	SW101~SW115	KPT-1115AM	5S50101Z93	15
58	WIRE COPPER 15mm	J101	1/0.50 TIN COATING	85801052GY	1
59	WIRE COPPER 10mm	J102~J104,J106	1/0.51 TIN COATING	85801052GY	4
60	WIRE COPPER 7.5mm	J105	1/0.51 TIN COATING	85801052GY	1
61	WIRE FLAT	WF1	1.25X15X90XC	WSJ-159007	1

S/M NO. : C1B4K0S002

**DAEWOO**

**DAEWOO ELECTRONICS CO., LTD.**

686, AHYEON-DONG MAPO-GU SEOUL, KOREA

C.P.O BOX 8003 SEOUL, KOREA

TELEX: DWELEC K28177-8

CABLE: "DAEWOOELEC"

PRINTED DATE: DEC, 2001