

S/M No. : OC154K8003

Service Manual

Microwave Oven

Model: KOC-154K8SA2

DAEWOO

✓ **Caution**

: In this Manual, some parts can be changed for improving, their performance without notice in the parts list. So, if you need the latest parts information, please refer to PPL(Parts Price List) in Service Information Center (<http://svc.dwe.co.kr>).

DAEWOO 
ELECTRONICS

Feb. 2008

PRECAUTIONS TO BE OBSERVED BEFORE AND DURING SERVICING TO AVOID POSSIBLE EXPOSURE TO EXCESSIVE MICROWAVE ENERGY

- (a) Do not operate or allow the oven to be operated with the door open.
 - (b) Make the following safety checks on all ovens to be serviced before activating the magnetron or other microwave source, and make repairs as necessary: (1) Interlock operation, (2) Proper door closing, (3) Seal and sealing surfaces (arcing, wear, and other damage), (4) Damage to or loosening of hinges and latches, (5) Evidence of dropping or abuse.
 - (c) Before turning on power to the microwave oven for any service test or inspection within the microwave generating compartments, check the magnetron, wave guide or transmission line, and cavity for proper alignment, integrity, and connections.
 - (d) Any defective or misadjusted components in the interlock, monitor, door seal, and microwave generation and transmission systems shall be repaired, replaced, or adjusted by procedures described in this manual before the oven is released to the owner.
- A microwave leakage check to verify compliance with the Federal performance standard should be performed on each oven prior to release to the owner.

TABLE OF CONTENTS

1. SAFETY AND PRECAUTIONS	2
2. SPECIFICATIONS	3
3. EXTERNAL VIEW	3
3-1. OUTER DIMENSION	3
3-2. FEATURE DIAGRAM	4
4. INSTALLATION	5
5. CONTROL PANEL	6
6. DISASSEMBLY AND ASSEMBLY	7
7. INTERLOCK MECHANISM AND ADJUSTMENT	18
8. TROUBLESHOOTING GUIDE	19
9. MEASUREMENT AND TEST	25
9-1. MEASUREMENT OF THE MICROWAVE POWER OUTPUT	25
9-2. MICROWAVE RADIATION TEST	26
9-3. COMPONENT TEST PROCEDURE.....	27
9-4. COMPONENT ACTION.....	28
10. WIRING DIAGRAM	29
11. EXPLODED VIEW AND PARTS LIST	31
11-1. DOOR ASSEMBLY.....	31
11-2. CONTROL PANEL ASSEMBLY.....	31
11-3. TOTAL ASSEMBLY	31
12. PRINTED CIRCUIT BOARD	35
13. P.C.B CIRCUIT DIAGRAM	39

1. SAFETY AND PRECAUTIONS

1. FOR SAFE OPERATION

Damage that allows the microwave energy (that cooks or heats the food) to escape will result in poor cooking and may cause serious bodily injury to the operator.

IF ANY OF THE FOLLOWING CONDITIONS EXIST, OPERATOR MUST NOT USE THE APPLIANCE. (Only a trained service personnel should make repairs.)

- 1) A broken door hinge.
- 2) A broken door viewing screen.
- 3) A broken front panel, oven cavity.
- 4) A loosened door lock.
- 5) A broken door lock.

The door gasket plate and oven cavity surface should be kept clean.

No grease, soil or spatter should be allowed to build up on these surfaces or inside the oven.

DO NOT ATTEMPT TO OPERATE THIS APPLIANCE WITH THE DOOR OPEN.

The microwave oven has concealed switches to make sure the power is turned off when the door is opened.

Do not attempt to defeat them.

DO NOT ATTEMPT TO SERVICE THIS APPLIANCE UNTIL YOU HAVE READ THIS SERVICE MANUAL.

2. FOR SAFE SERVICE PROCEDURES.

1. If the oven is operative prior to servicing, a microwave emission check should be performed prior to servicing the oven.
2. If any certified oven unit is found to servicing, a microwave emission check should be performed prior to servicing the oven.
 - (a) inform the manufacturer, importer or assembler,
 - (b) repair the unit at no cost to the owner,
 - (c) attempt to ascertain the cause of the excessive leakage,
 - (d) tell the owner of the unit not to use the unit until the oven has been brought into compliance.
3. If the oven operates with the door open, the service person should tell the user not to operate the oven and contact the manufacturer immediately.

IMPORTANT

The wire in this mains lead coloured in accordance with the following code.

Green-and-yellow	: Earth
Blue	: Neutral
Brown	: Live

As the colours of the wires in the mains lead of this appliance may not correspond with the coloured markings identifying the terminals in your plug, proceed as follows.

The wire which is coloured green-and-yellow must be connected to the terminal in the plug which is marked with the letter 'E' or by earth symbol or green-and-yellow.

The wire which is coloured blue must be connected to the terminal which is marked with the letter 'N' or coloured black.

The wire which is coloured brown must be connected to the terminal which is marked with the letter 'L' or coloured red.

NOTE : This oven is designed for counter-top use only.

2. SPECIFICATIONS

MODEL		KOC-154K8S
POWER SUPPLY		230V~50Hz, SINGLE PHASE WITH EARTHING
POWER CONSUMPTION	MICROWAVE	1550W
	GRILL	1550W
	CONVECTION	2550W
	COMBINATION	2950W
MICROWAVE ENERGY OUTPUT		950W(IEC705)
MICROWAVE FREQUENCY		2450MHz
OUTSIDE DIMENSIONS (W X H X D)		582X379.1X518.2mm (22.9x14.9x20.4 in.)
CAVITY DIMENSIONS (W X H X D)		390X285.5X383mm (15.4x11.2x15.1 in.)
NET WEIGHT		APPROX. 23.1kg (50.9 lbs.)
TIMER		60 minutes
FUNCTION SELECTIONS		MICROWAVE/ GRILL/ CONVECTION/ COMBINATION
POWER SELECTIONS		10 LEVELS
CAVITY VOLUME		1.5 Cu. Ft

* Specifications are subject to change without notice.

3. EXTERNAL VIEW

1. OUTER DIMENSION

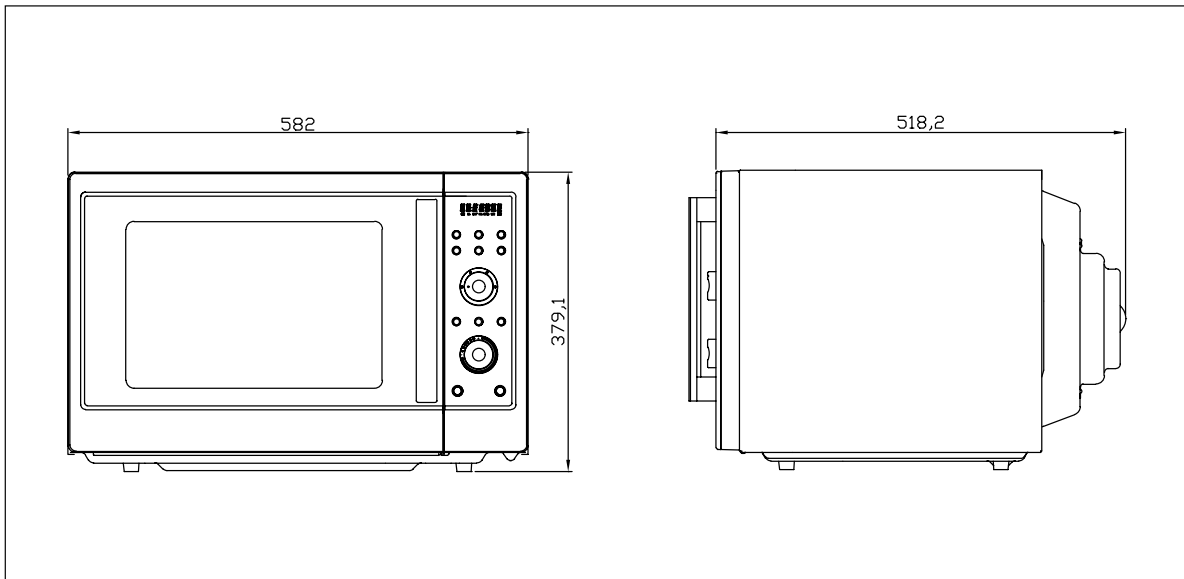

2. FEATURE DIAGRAM

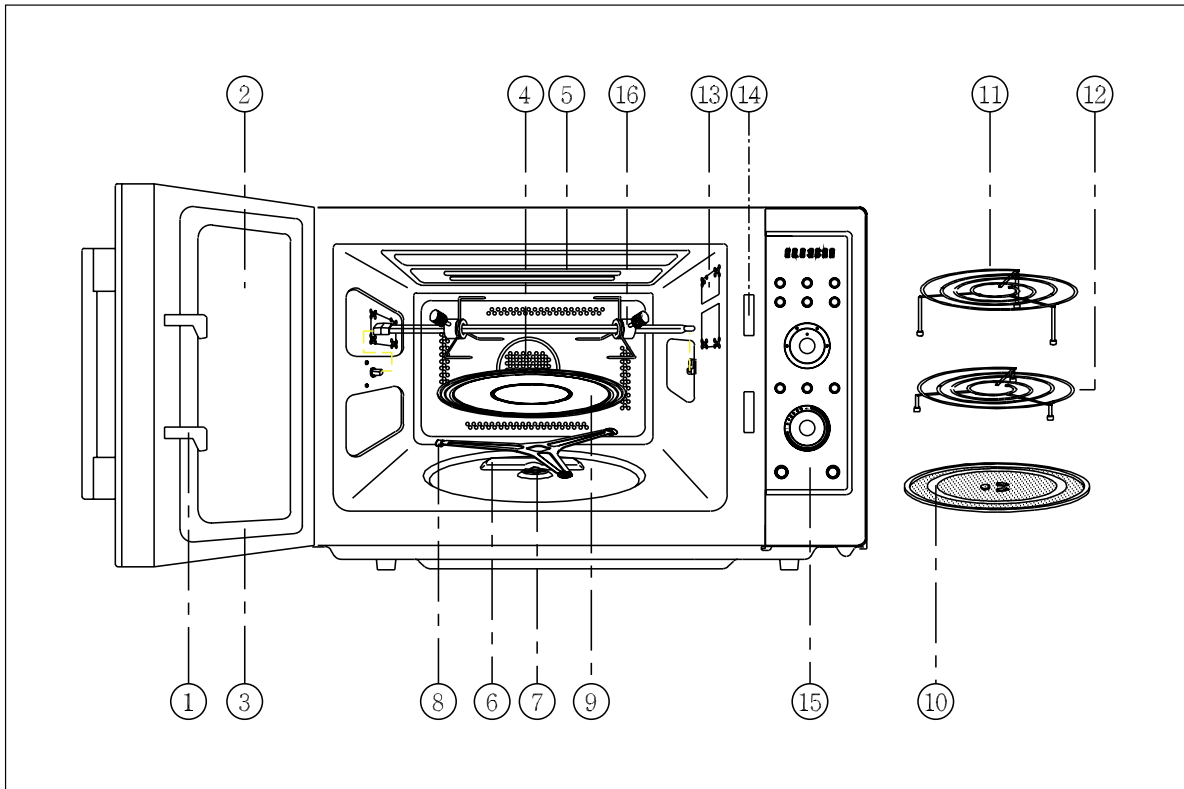

1. DOOR HOOK

When the door is closed, it will automatically lock shut. If door is opened while oven is operating, the magnetron will immediately stop operating.

2. DOOR VIEWING SCREEN

Allows viewing of food. The screen is designed so that light can pass through, but not the microwave.

3. DOOR SEAL

Door seal maintains the microwave energy within the oven cavity and prevents microwave leakage.

4. CONVECTION OUTLET & FAN

5. TOP HEATER

Turns on when convection, grill and combi cooking is selected.

6. UNDER HEATER

7. COUPLER

This fits over the shaft in the center of the ovens cavity floor. This is to remain in the oven for all cooking.

8. ROLLER GUIDE

This must always be used for cooking together with the turntable tray.

9. METAL TURNTABLE TRAY

This is to be used for convection, combination and grill cooking. It rotates during cooking.

10. GLASS TURNTABLE TRAY

This is to be used for microwave cooking. It rotates during cooking.

11. METAL RACK (High)

12. METAL RACK (Low)

13. OVEN LAMP

Automatically turns on during oven operating.

14. SAFETY INTERLOCK SYSTEM

15. CONTROL PANEL

16. BARBECUE BAR (KOC-154K8SA2)

This is used barbecue cooking.

4. INSTALLATION

1. Steady, flat location

This microwave oven should be set on a steady, flat surface.
This microwave oven is designed for counter top use only.

2. Leave space behind and side

All air vents should be kept a clearance. If all vents are covered during operation, the oven may overheat and, eventually, cause failure.

3. Away from Radio and TV sets

Poor television reception and radio interference may result if the oven is located close to a TV, Radio, antenna or feeder and so on.
Position the oven as far from them as possible.

4. Away from heating appliances and water taps

Keep the oven away from hot air, steam or splash when choosing a place to position it, or the insulation might be adversely affected and breakdowns occur.

5. Power supply

- Check your local power source. This microwave oven requires a current of approximately 13(8) amperes, 230V, 50Hz.
- Power supply cord is about 1.2 meters long.
- The voltage used must be the same as specified on this oven. Using a higher voltage may result in a fire or other accident causing oven damage. Using low voltage will cause slow cooking. We are not responsible for damage resulting from use of this oven with a voltage of ampere fuse other than those specified.
- This appliance is supplied with cable of special type, which, if damaged, must be repaired with cable of same type. Such a cable can be purchased from DAEWOO and must be installed by a Qualified Person.

6. Examine the oven after unpacking for any damage such as:

A misaligned door, broken door or a dent in cavity.
If any of the above are visible, DO NOT INSTALL, and notify dealer immediately.

7. Do not operate the oven if it is colder than room temperature.

(This may occur during delivery in cold weather.) Allow the oven to become room temperature before operating.

EARTHING INSTRUCTIONS

This appliance must be earthed. In the event of an electrical short circuit, earthing reduces the risk of the electric shock by providing an escape wire for the electric current. This appliance is equipped with a cord having a earthing wire with a earthing plug. The plug must be plugged into an outlet that is properly installed and earthed.

WARNING

Improper use of the earthing plug can result in a risk of electric shock. Consult a qualified electrician or serviceman if the earthing instructions are not completely understood, or if doubt exists as to whether the appliance is properly earthed, and either:
If it is necessary to use an extension cord, use only a 3-wire extension cord that has a 3-blade earthing plug, and a 3-slot receptacle that will accept the plug on the appliance.
The marked rating of the extension cord should be equal to or greater than the electrical rating of the appliance, or
Do not use an extension cord.

5. CONTROL PANEL

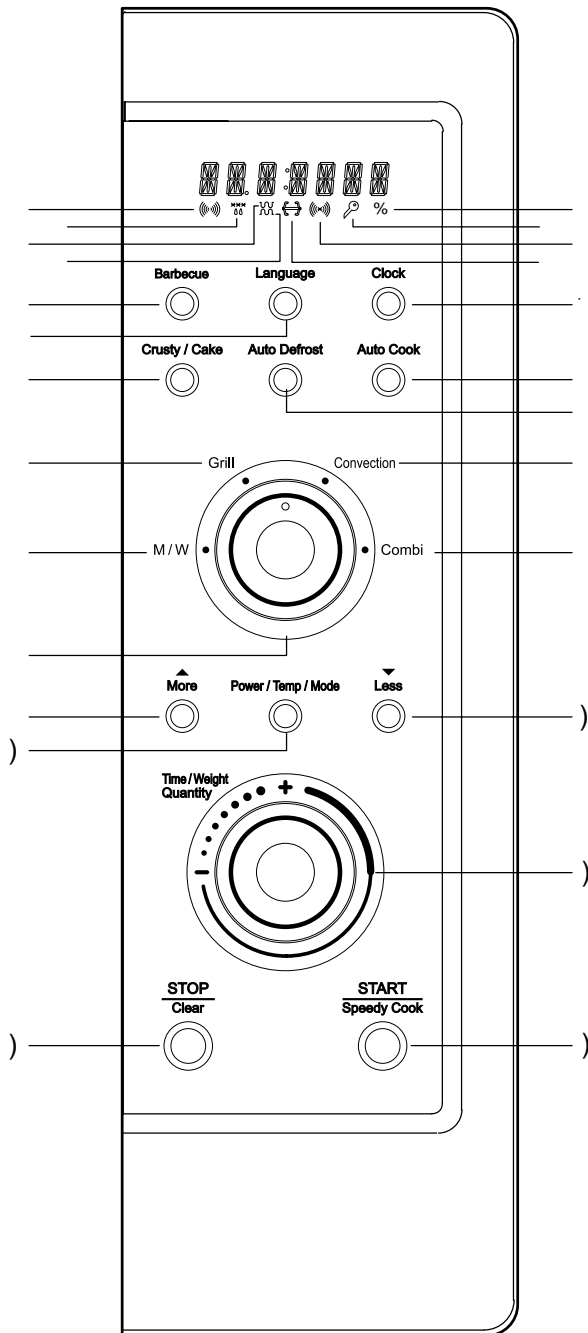

DISPLAY WINDOW

1. **MICROWAVE** - indicator, showing microwaving in progress.
2. **DEFROST** - indicator, showing defrosting in progress.
3. **GRILL(upper grill heater)** - indicator, showing griling in progress.
4. **GRILL(lower grill heater)** - indicator, showing griling in progress.
5. **CONVECTION** - indicator, showing convectioning in progress.
6. **CHILD LOCK** - indicator.
7. **%** - percentage microwave power level indicator.
8. **BARBECUE** - indicator

BUTTONS

9. **memory** - Use to select barbecue.
10. **language** - Press to select the language.
11. **clock** - Use to set clock.
12. **crusty/cake** - Press to select crusty/cake menu.
13. **auto cook** - Press to select auto cook menu.
14. **auto defrost** - Press to select defrost menu.
15. **grill** - Use to select grill.
16. **convection** - Use to select convection.
17. **m/w** - Use to select microwave.
18. **combi** - Use to select combi.
19. **Menu Knob** - Use to select menus.
20. **more** - Use to add time to cooking.
21. **less** - Use to reduce cooking time.
22. **Power/Temp/Mode** - Use to set power, temperature and grill/combi mode.
23. **dial knob** - Use to set time, weight and quantity.
24. **stop/clear** - Press once to stop a programme, and twice to cancel a programme.
25. **start/speedy cook** - Press to start a programme, also for speedy start (each press adds 30 seconds to microwave cooking time).

6. DISASSEMBLY AND ASSEMBLY

- Cautions to be observed when trouble shooting.

Unlike many other appliances, the microwave oven is high-voltage, high-current equipment.

It is completely safe during normal operation. However, carelessness in servicing the oven can result in an electric shock or possible danger from a short circuit.

You are asked to observe the following precautions carefully.

1. Always remove the power plug from the outlet before servicing.
2. Use an insulated screwdriver and wear rubber gloves when servicing the high voltage side.
3. Discharge the high voltage capacitor before touching any oven components or wiring.

(1) Check the earthed.

Do not operate on a two-wire extension cord.

The microwave oven is designed to be used with earthed.

It is imperative, therefore, to make sure it is earthed properly before beginning repair work.

(2) Warning about the electric charge in the high voltage capacitor.

For about 30 seconds after the operation stopped and electric charge remains in the high voltage capacitor. When replacing or checking parts, short between oven chassis and the negative high terminal of the high voltage capacitor, by using a properly insulated screwdriver to discharge.

4. When the 15A fuse is blown out due to the operation of the monitor switch; replace primary interlock switch, secondary interlock switch and interlock monitor switch.
5. After repair or replacement of parts, make sure that the screws are properly tightened, and all electrical connections are tightened.
6. Do not operate without cabinet.

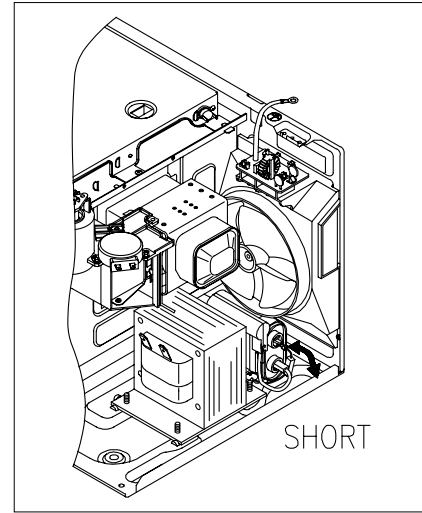

CAUTION : Service personnel should remove their watches whenever working close to or replacing the magnetron.

WARNING : When servicing the appliance, need a care of touching or replacing high potential parts because of electrical shock or exposing microwave. These parts are as follows - HV Transformer, Magnetron, HV Capacitor, HV Diode.

1. To remove cabinet

- 1) Remove 5 screws on the cabinet back and side.
- 2) Push the cabinet backward.

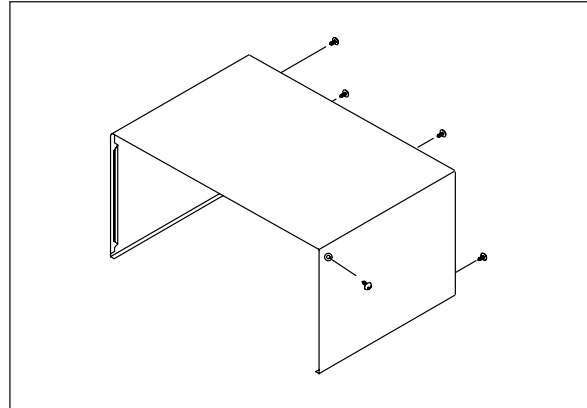

2. To remove door assembly

- 1) Remove two screws which secure the stopper hinge top.
- 2) Remove the door assembly from top plate of cavity.
- 3) Reverse the above for reassembly.

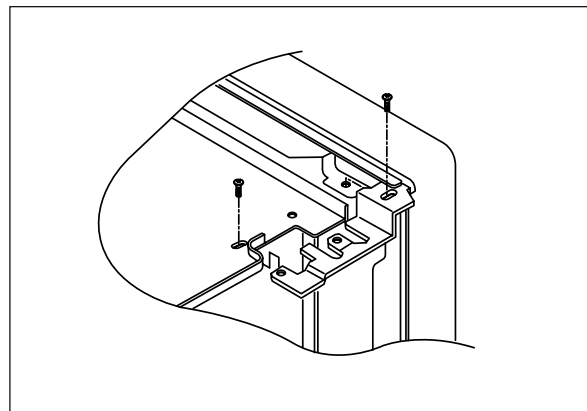

NOTE : After replacing the door assembly, perform a check of correct alignment with the hinge and cavity front plate.

3. To remove door parts.

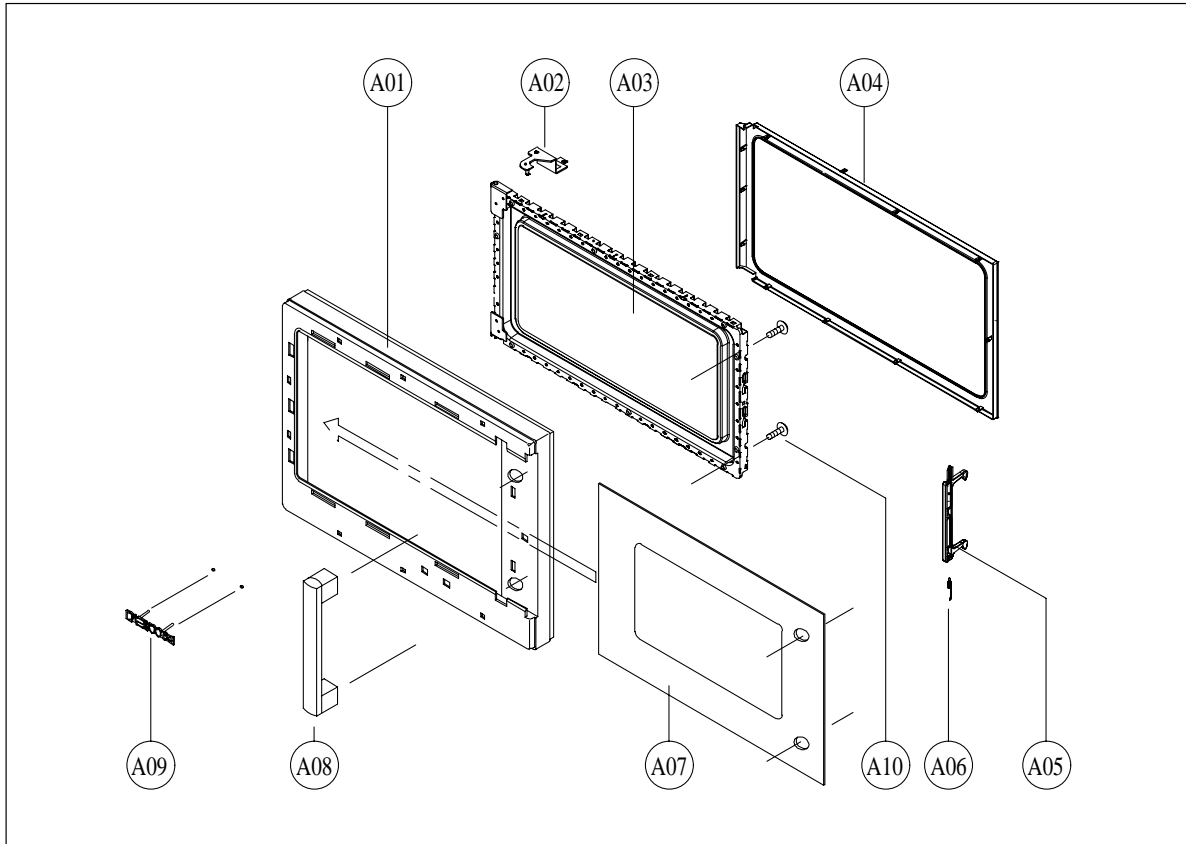

NO	PARTS CODE	PARTS NAME	DESCRIPTION	Q'TY	REMARK
A01	3512210300	FRAME DOOR	PC	1	
A02	3515204900	STOPPER HINGE *T AS	KOC-1B0K0S	1	
A03	3511714110	DOOR SEAL AS	KOC-154K8S	1	
A04	3512302800	GASKET DOOR	PBT	1	
A05	3513101800	HOOK	POM	1	
A06	3515101800	SPRING HOOK	PW1	1	
A07	3517008920	BARRIER-SCREEN *O	GLASS T3.2 TEMPERED	1	
A08	3512607400	HANDLE AS	KOC-154K8S	1	
A09	3516006800	SPECIAL BADGE	AL KOC-154K8S	1	
A10	7122401211	SCREW TAPPING	T2S TRS 4X12	2	

-
- (1) Remove the gasket door from door plate.
 - (2) Remove two screws from the handle assembly secured to door frame.
 - (3) Remove the handle door and barrier screen outer from door frame.
 - (4) Remove the door frame from door plate.
 - (5) Remove the stopper hinge top from door plate.
 - (6) Remove the spring and the hook.
 - (7) Reverse the above steps for reassembly.

4. Method to reduce the gap between the door seal and the oven front surface.

- (1) To reduce gap located on part 'A'.
 - Loosen two screws on stopper hinge top, and then push the door to contact the door seal to oven front surface.
 - Tighten two screws.
- (2) To reduce gap located on part 'B'.
 - Loosen two screws on stopper hinge under, and then push the door to contact the door seal to oven front surface.
 - Tighten two screws.

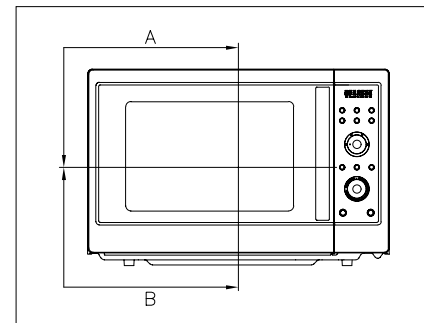

NOTE : A small gap may be acceptable if the microwave leakage does not exceed 4mW/cm².

5. To remove control panel parts.

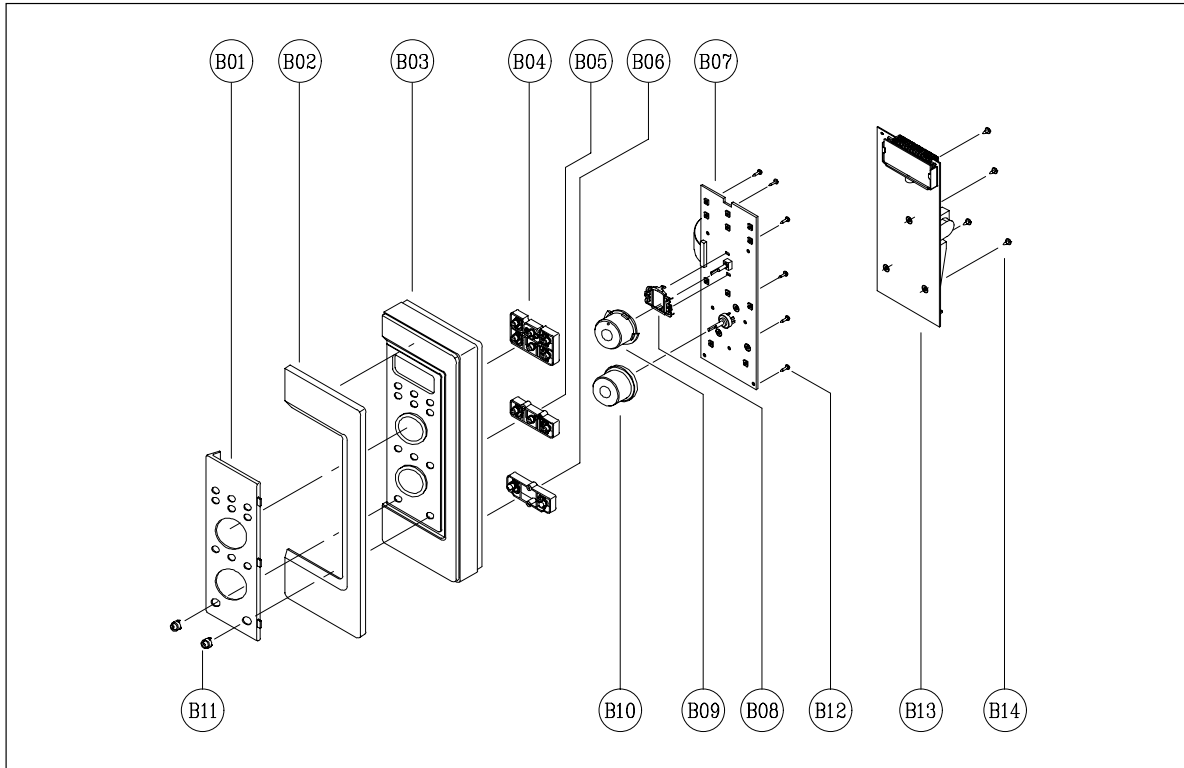

NO	PARTS CODE	PARTS NAME	DESCRIPTION	Q'TY	REMARK
B01	3511617330	DECORATOR C-PANEL	KOC-154K8SA2	1	
B02	3511617300	DECORATOR C-PANEL	STS T0.5#4	1	
B03	3516735400	CONTROL-PANEL	ABS	1	
B04	3516916000	BUTTON FUNCTION-A	ABS	1	
B05	3516916100	BUTTON FUNCTION-B	ABS	1	
B06	3516916200	BUTTON FUNCTION-C	ABS	1	
B07	PKBPMFSF200	PCB BUTTON MANUA AS	KOC-154K8S	1	
B08	3517401700	COUPLER VPC KNOB	POM	1	
B09	3513411400	KNOB FUNCTION	ABS	1	
B10	3513411500	KNOB VOLUME	ABS	1	
B11	3511617400	DECORATOR RING	ABS	2	
B12	7621301011	SCREW TAPPING	T2S PAN 3X10	11	
B13	PKMPMSF230	PCB MAIN MANUAL AS	KOC-154K8SA2	1	
B14	7122401211	SCREW TAPPING	T2S TRS 4X12	4	

- (1) Remove four screws(B14) which secure the control panel.
- (2) Pull out the main PCB assembly(B13).
- (3) Remove 11 screws(B12) which secure the control panel.
- (4) Pull out the sub PCB assembly(B07).
- (5) Pull out the knob function (B09) and the knob volume(B10) from the sub PCB assembly.
- (6) Pull out the coupler vpc knob (B08) from the sub PCB assembly.
- (7) Pull out three buttons from the control panel.
- (8) Pull out decorator ring(B11) from the control panel.
- (9) Pull out the decorator c-panel (B01) from the control panel.
- (10) Reverse the above steps for reassembly.

6. To remove high voltage capacitor.

- (1) Remove a screw which secure the grounding ring terminal of the H.V. diode and the capacitor holder.
- (2) Remove the H.V. diode from the capacitor holder.
- (3) Reverse the above steps for reassembly.

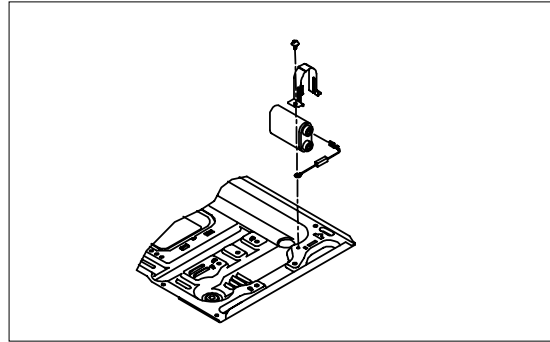

◆ High voltage circuit wiring

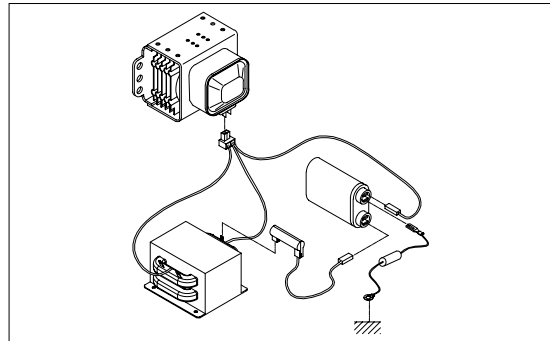

7. To remove magnetron.

- (1) Remove a screw which secure the magnetron.
- (2) Remove the magnetron.
- (3) Reverse the above steps for reassembly.

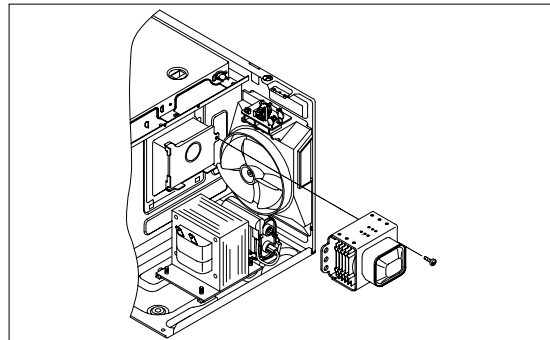

CAUTION : Never install the magnetron without the metallic gasket plate which is packed with each magnetron to prevent microwave leakage. Whenever repair work is carried out on magnetron, check the microwave leakage. It shall not exceed $4\text{mW}/\text{cm}^2$ for a fully assembled oven with door normally closed.

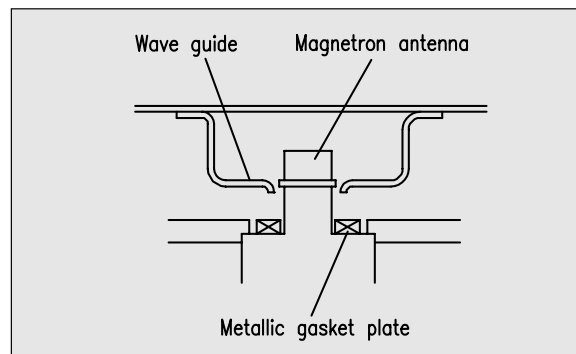
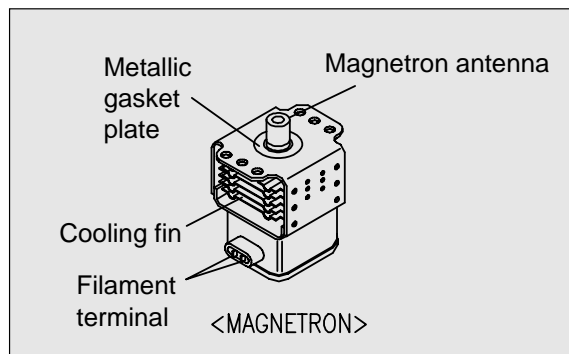

8. To remove wind guide assembly.

- (1) Remove a screw for earthing.
- (2) Remove the noise filter from the wind guide.
- (3) Remove a screw which secure the wind guide assembly.
- (4) Draw forward the wind guide assembly.
- (5) Pull the fan from the motor shaft.
- (6) Remove two screws which secure the motor shaded pole.
- (7) Remove the motor shaded pole.
- (8) Reverse the above steps for reassembly.

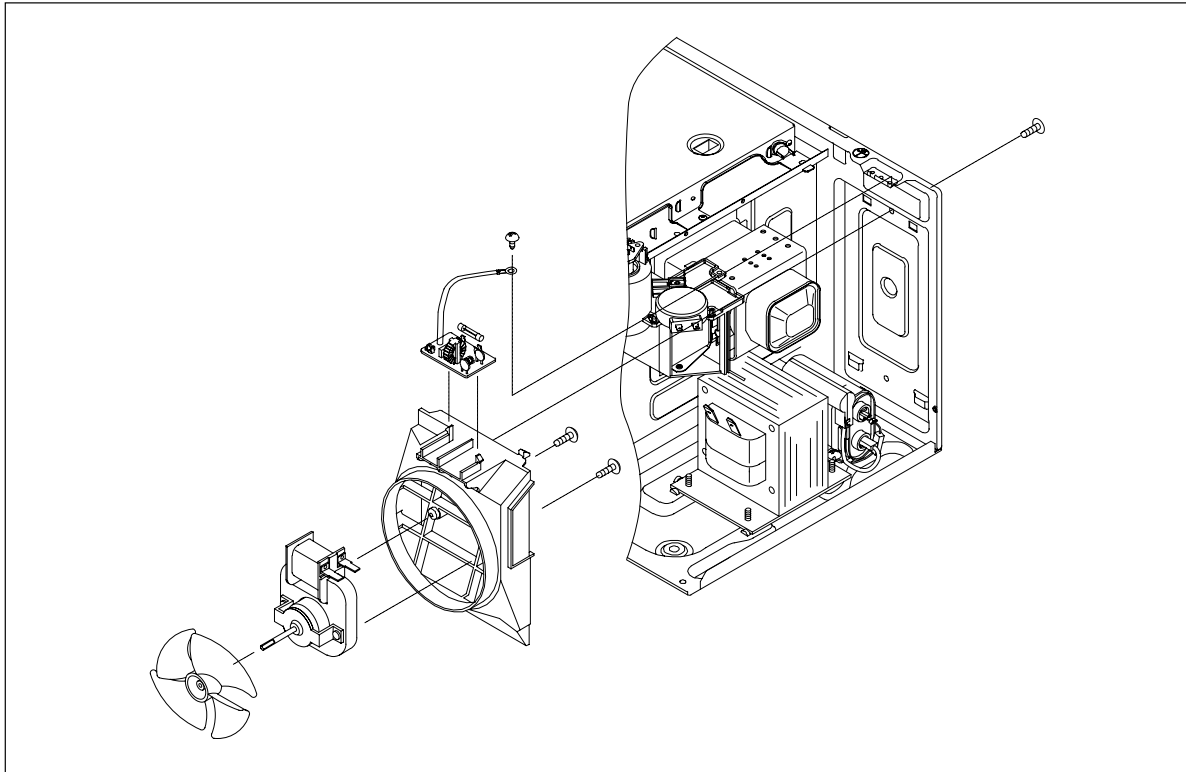

9. To remove H.V.transformer.

- (1) Remove four screws holding the H.V transformer.
- (2) Remove the H.V.transformer.
- (3) Reverse the above steps for reassembly.

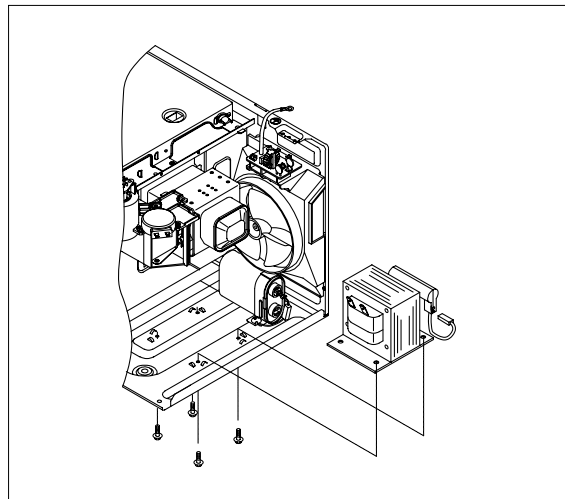

10. To remove Guide air assembly parts.

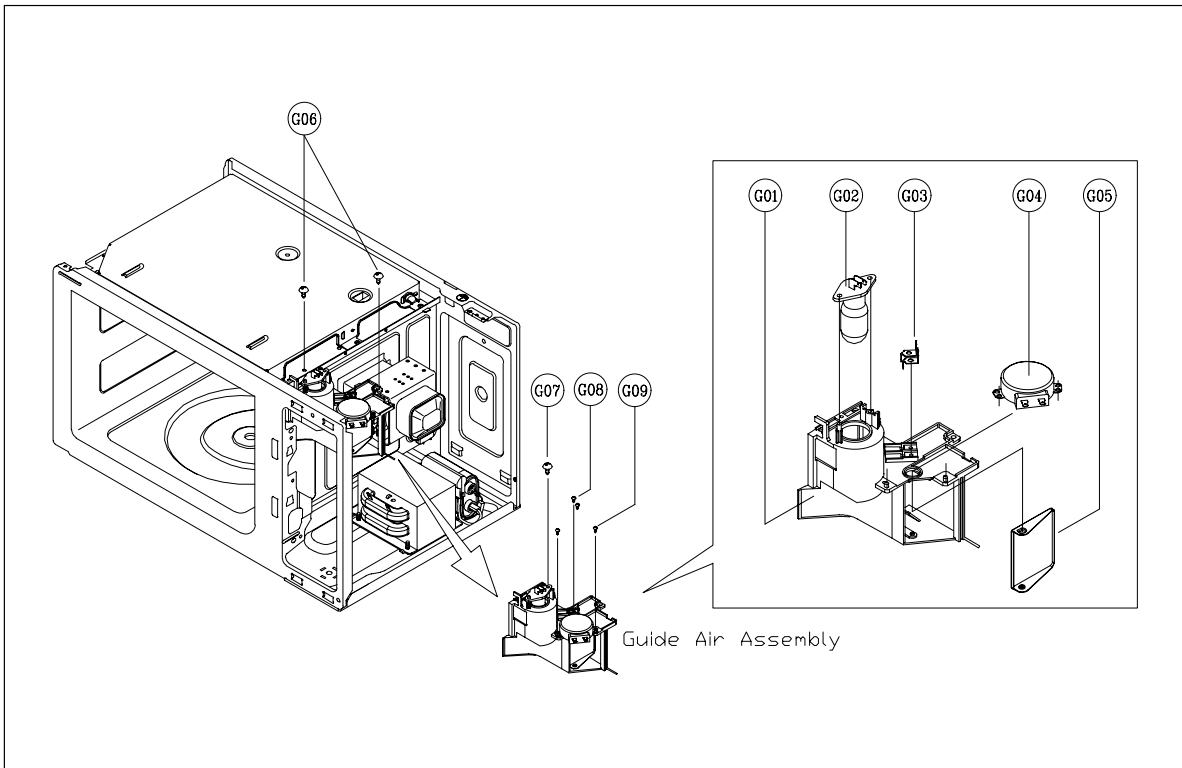

NO	PARTS CODE	PARTS NAME	DESCRIPTION	Q'TY	REMARK
G01	3512525200	GUIDE AIR	PBT	1	
G02	3513601600	LAMP	BL 240V 25W T25 C7A H187	1	
G03	3515102700	SPRING TERMINAL	SUS301 T0.5	2	
G04	3966310100	MOTOR SYNCRO	220V 2.5W GM-16-24FD12	1	
G05	3510609100	BRACKET DAMPER	SBHG T0.7	1	
G06	7112401011	SCREW TAPPING	T1 TRS 4X10	2	
G07	7112401011	SCREW TAPPING	T1 TRS 4X10	1	
G08	7121400611	SCREW TAPPING	T2S PAN 4X6	2	
G09	7121400611	SCREW TAPPING	T2S PAN 4X6	2	

- 1) Remove two screws (G06) and pull out Guide air assembly.
- 2) Remove a screws (G07) and pull out the lamp.
- 3) Remove two screws (G08) and pull out the two spring terminals.
- 4) Remove two screws (G09).
- 5) Pull out the motor and the bracket damper.
- 6) Reverse the above steps for reassembly.

11. To remove Top heater assembly parts.

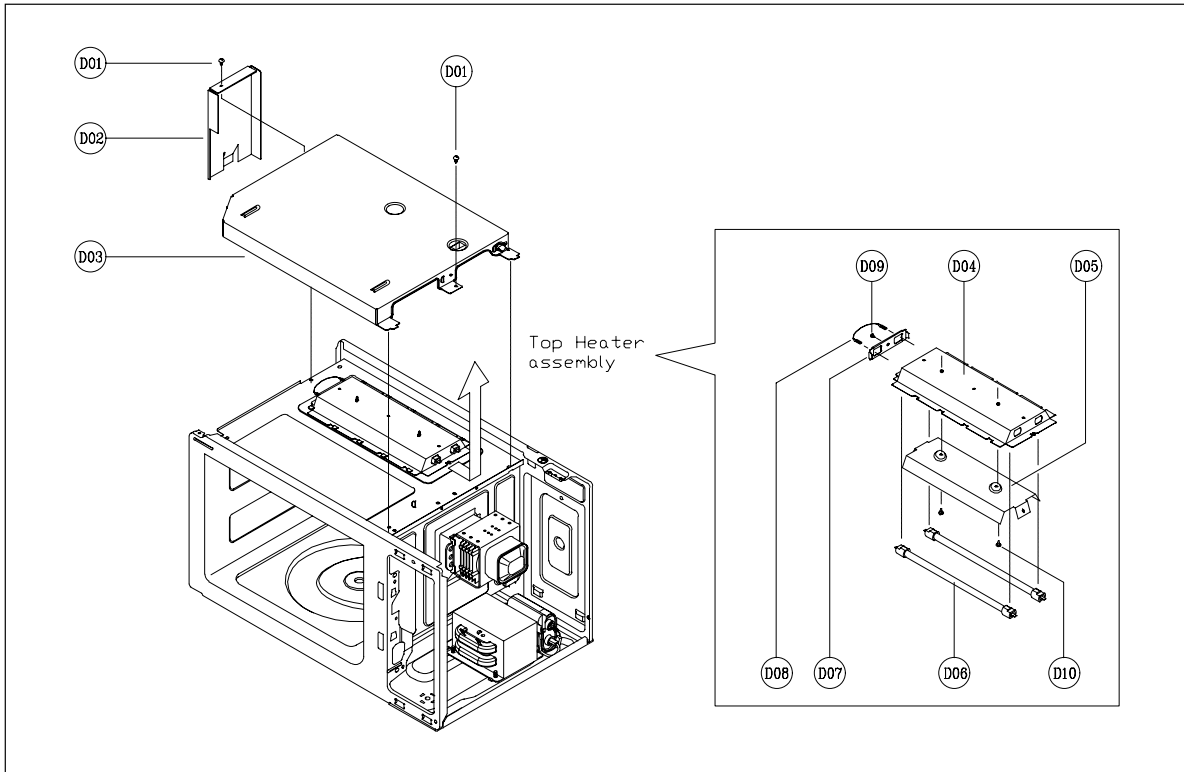

REF NO.	PART CODE	PART NAME	DESCRIPTION	Q'TY	REMARK
D01	7112401011	SCREW TAPPING	T1 TRS 4X10	2	
D02	3512523600	GUIDE AIR OUTLET	SBHG T0.5	1	
D03	3513304000	INSULATOR HEATER *T	SECC TO.5	1	
D04	3511407600	COVER HEATER *T	STS430 T0.4	1	
D05	3512806010	REFLECTOR HEATER *T	SUS	1	
D06	3512803800	HEATER MIRACLON	115V 550W 270MM	2	
D07	3510607700	BRACKET HEATER *T	SA1D-80 T0.5	1	
D08	3512767000	HARNES HEATER	KOC-1B0K0S	1	
D09	7S432X4081	SPECIAL SCREW	TT3 TRS 4X8 SE MFZN	1	
D10	7122408114	SCREW TAPPING	T2S TRS 4X6 MFNI	2	

- 1) Remove two screws (D01) and pull out Guide air outlet (D02) and insulator heater *t (D03).
- 2) Pull out the Top heater assembly.
- 3) Pull out the Harness heater (D08).
- 4) Remove a screw (D09).
- 5) Pull out the Braket heater*t(D07) from the Cover heater*t(D04).
- 6) Pull out the Heater miraclon(D06) from the Cover heater*t(D04).
- 7) Remove two screws (D10).
- 8) Remove reflector heater *t (D05).
- 9) Reverse the above steps for reassembly.

12. To remove Rear heater assembly parts.

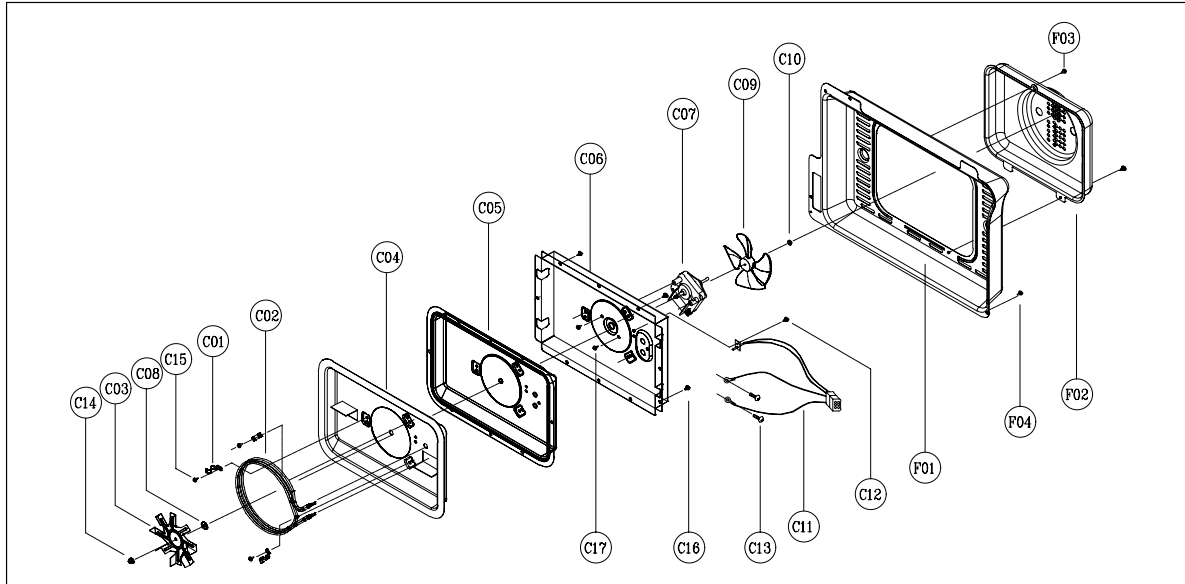

REF NO.	PART CODE	PART NAME	DESCRIPTION	Q'TY	REMARK
F01	3511413500	COVER *B	SBHG-3 TO.4	1	
F02	3511410500	COVER MOTOR *B	SA1D-80 T0.5	1	
F03	7112401011	SCREW TAPPING	T1 TRS 4X10	2	
F04	7112401011	SCREW TAPPING	T1 TRS 4X10	1	
C01	3513002300	HOLDER HEATER	SUS304 T0.5	3	
C02	3512801800	HEATER	230V 1400W 1R18344	1	
C03	3511800700	FAN CONVECTION	SA1D-80 T0.5	1	
C04	3512806000	HEATER REFLECTOR	SA1D T0.5	1	
C05	3511409800	COVER HEATER *B	SA1D-80 T0.5	1	
C06	3513303400	INSULATOR HEATER *B	SBHG-1 T0.5	1	
C07	3963514330	MOTOR SHADED POLE	230V 50HZ MW10CA-T03	1	
C08	7400104011	WASHER PLAIN	PW-1-4 MFZN	1	
C09	3511800900	FAN	PBT	1	
C10	7402704600	RING C	CR-5 SK5	1	
C11	3512781310	HARNES CONVECTION AS	KOC-154K8S	1	
C12	7113400814	SCREW TAPPING	T1 BIN 4X8 MFNI	1	
C13	7001401065	SCREW MACHINE	PAN 4X10 BSNI	2	
C14	7S627W40X1	SPECIAL SCREW	NUT FLANGE M4	1	
C15	7113400814	SCREW TAPPING	T1 BIN 4X8 MFNI	3	
C16	7113400814	SCREW TAPPING	T1 BIN 4X8 MFNI	4	
C17	7601400811	SCREW MACHINE	PAN 4X8 PW	2	

- 1) Remove two screws (F03) and pull out Cover motor *B (F02).
- 2) Remove a screw (F04) and pull out Cover *B (F01).
- 3) Remove three screws (C12) (C13) and pull out the harness convection (C11).
- 4) Remove four screws (C16) and then pull out the Rear heater assembly.
- 5) Remove the C-Ring (C10) and then pull out the Fan (C09) from Motor shaft.
- 6) Remove a Nut (C14) and the pull out the Fan convection (C03) and Washer plain (C08).
- 7) Remove three screws (F15) and pull out the holder heater (C01) and the heater (C02).
- 9) Remo two screws (C17) and then separate the Insulator heater *B (C06) and Motor shaded pole (C07).
- 10) Reverse the above steps for reassembly.

13. To remove Motor synchro. And Under heater assembly parts.

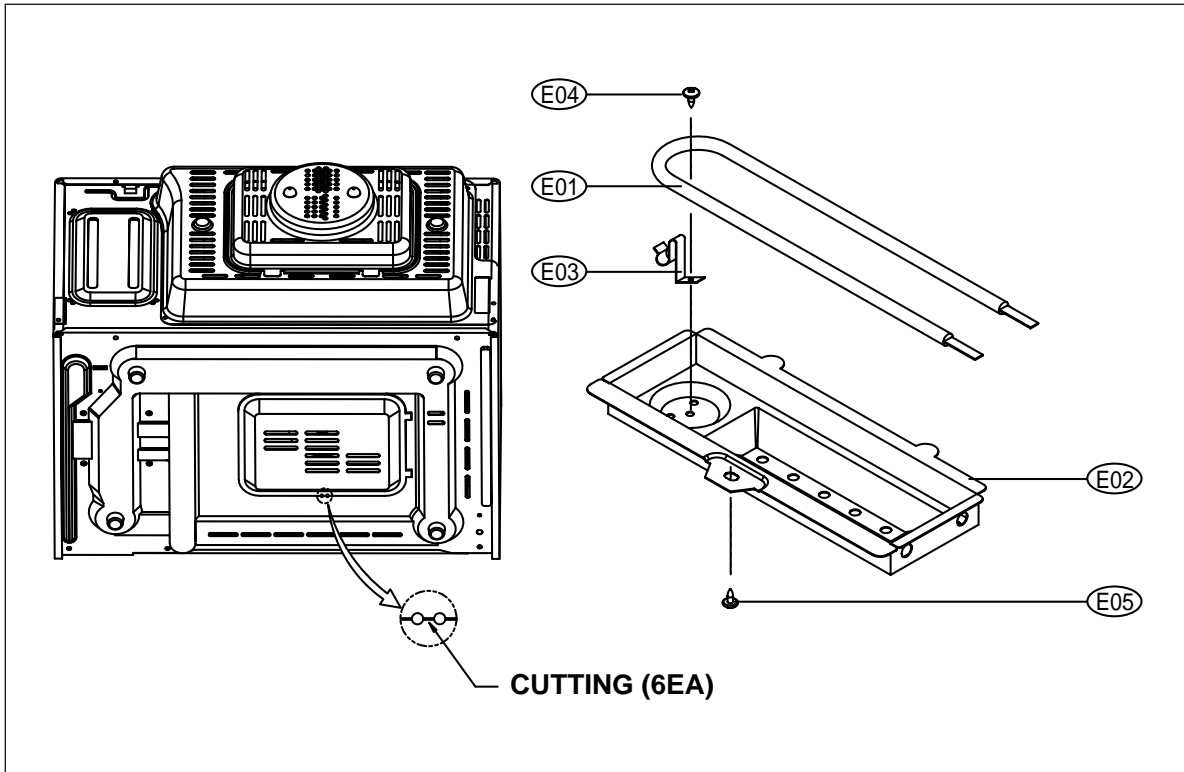

REF NO.	PART CODE	PART NAME	DESCRIPTION	Q'TY	REMARK
E01	3512802000	HEATER *U	230V 400W R18374001	1	
E02	3511407500	COVER HEATER *U	STS430 T0.5	1	
E03	3515304000	SUPPORTER HEATER *U	STS430 T0.5	1	
E04	7113400814	SCREW TAPPING	T1 BIN 4X8 MFNI	1	
E05	7113400814	SCREW TAPPING	T1 BIN 4X8 MFNI	1	

- 1) Cut the Motor synchro. Cover parts from the base plate.
- 2) Remove a screw and then pull out Motor synchro.
- 3) Remove a screw (E05) and then pull out the Under heater *U. assembly.
- 4) Remove a screw (E04).
- 5) Pull out the Heater *U (E01) from the Cover heater *U (E02).
- 6) Reverse the above steps for reassembly.

7. INTERLOCK MECHANISM AND ADJUSTMENT

The door lock mechanism is a device which has been specially designed to completely eliminate microwave radiation when the door is opened during operation, and thus to perfectly prevent the danger resulting from the leakage of microwave.

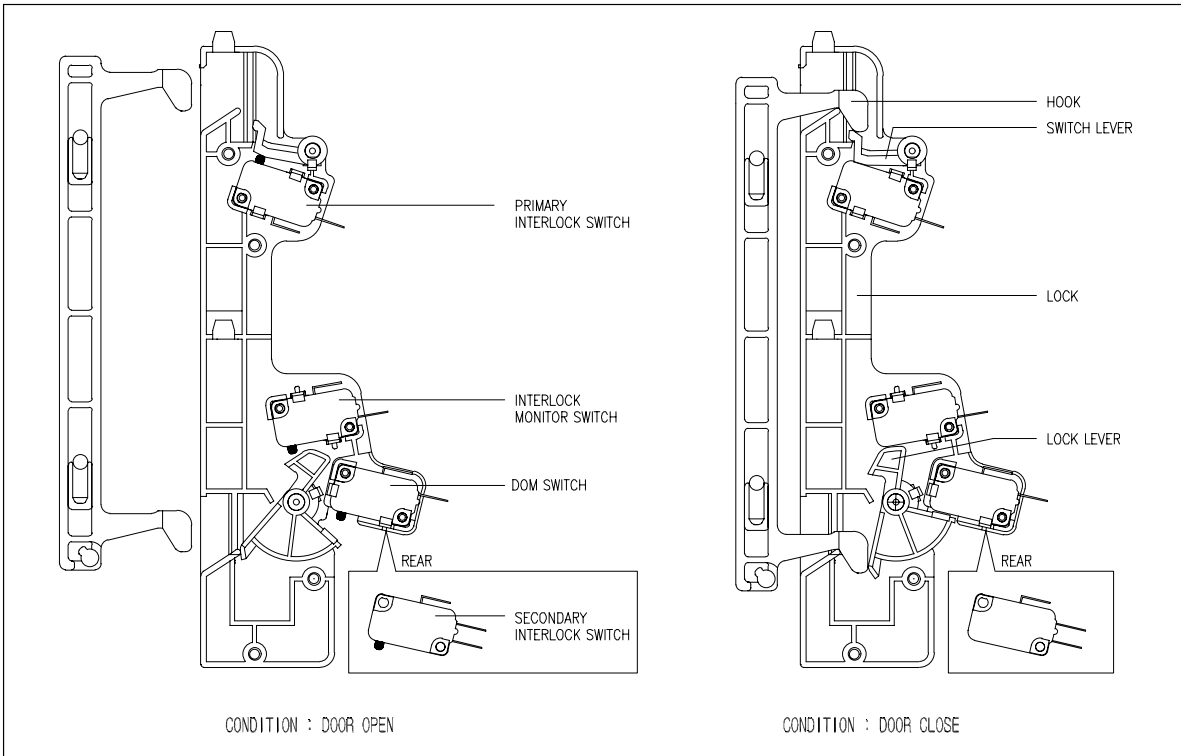

(1) Primary interlock switch

When the door is closed, the hook locks the oven door. If the door is not closed properly, the oven will not operate.

When the door is closed, the hook pushes the lock lever downward. The lock lever presses the button of the microswitch.

Then the button of the primary interlock switch bring it under "ON" condition.

(2) Secondary interlock switch and interlock monitor switch

When the door is closed, the hook pushes the lock lever downward. The lock lever presses the button of the interlock monitor switch to bring it under "OFF" condition and presses the button of the secondary interlock switch to bring it under "ON" condition.

ADJUSTMENT :

Interlock monitor switch

When the door is closed, the interlock monitor switch should be opened before other switches are closed.

When the door is opened, the interlock monitor switch should be closed after other switches are opened.

(3) Adjustment steps

- Loosen the one mounting screw.
- Adjust interlock switch assembly position.
- Make sure that lock lever moves smoothly after adjustment is completed.
- Tighten completely one mounting screw.

NOTE :

Microwave emission test should be performed after adjusting interlock mechanism.

If the microwave emission exceed $4\text{mW}/\text{cm}^2$, readjust interlock mechanism.

8. TROUBLESHOOTING GUIDE

Following the procedure below to check if the oven is defective or not.

- 1) Check grounding before trouble checking.
- 2) Be careful of the high voltage circuit.
- 3) Discharge the high voltage capacitor.
- 4) When checking the continuity of the switches, fuse or high voltage transformer, disconnect one load wire from these parts and check continuity with the AC plug removed. To do otherwise may result in a false reading or damage to your meter.

NOTE : When electric parts are checked, be sure the power cord is not inserted the wall outlet.
Check wire harness, wiring and connection of the terminals and power cord before check the parts listed below.

(TROUBLE 1) Oven does not operate at all : any inputs can not be accepted.

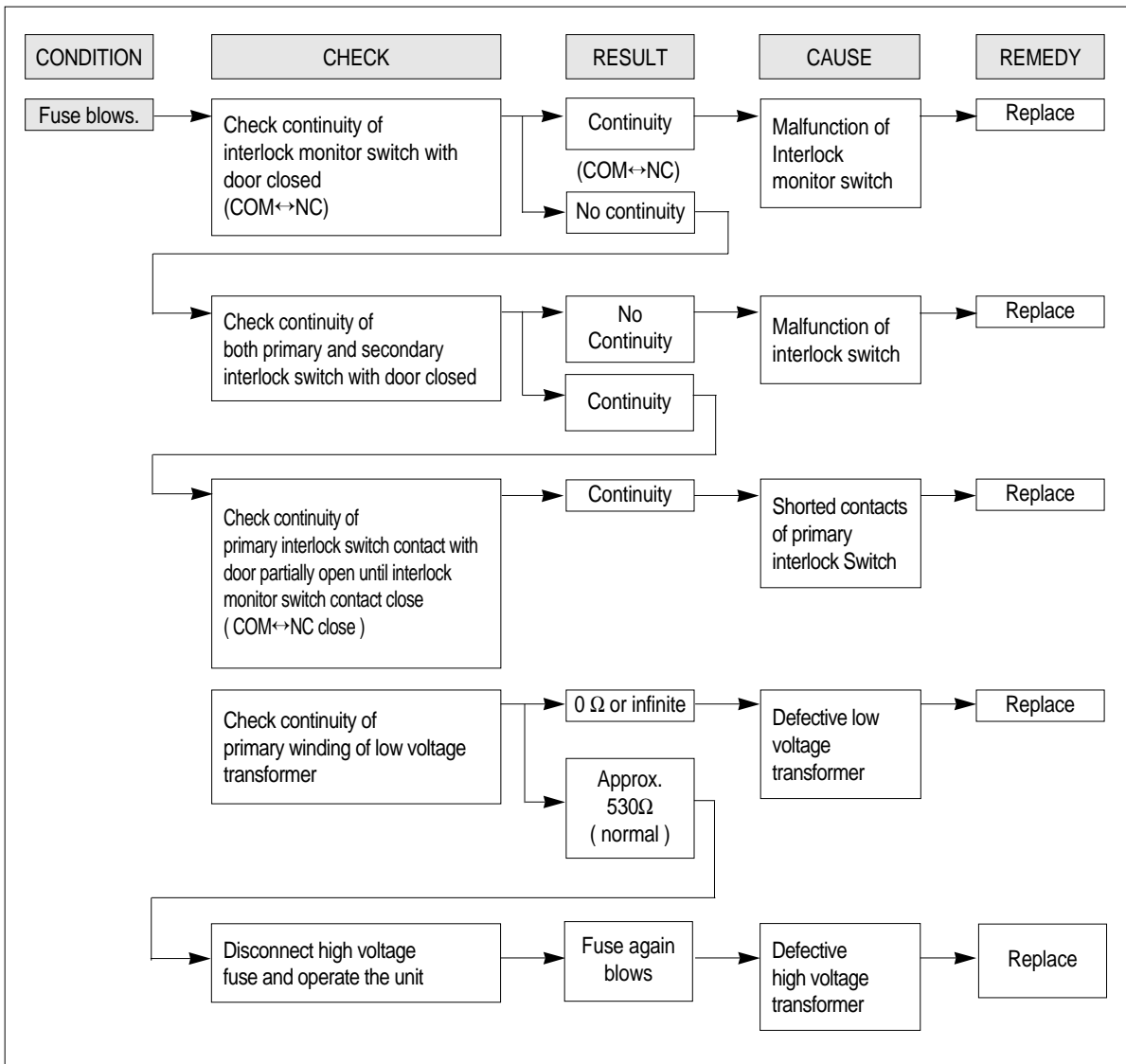

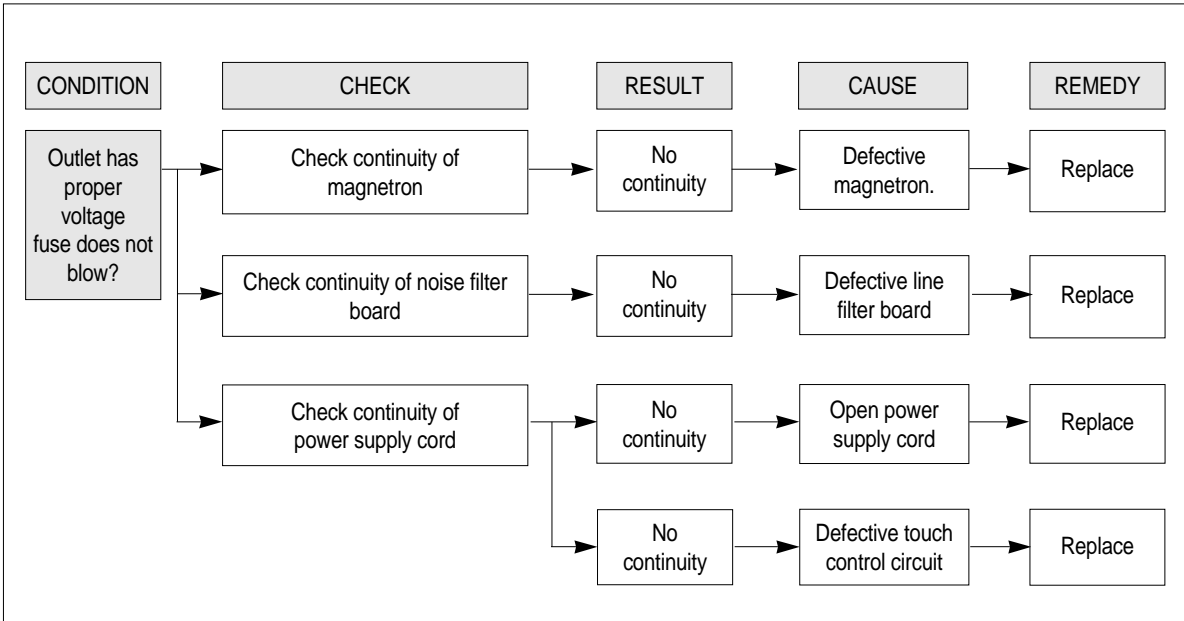

NOTE : All these switches must be replaced at the same time, please refer to (7.Interlock mechanism and adjust) for adjustment instructions

(TROUBLE 2)

Display shows all figures selected, but oven does not start cooking, even though desired program and time are set and start button is tapped.

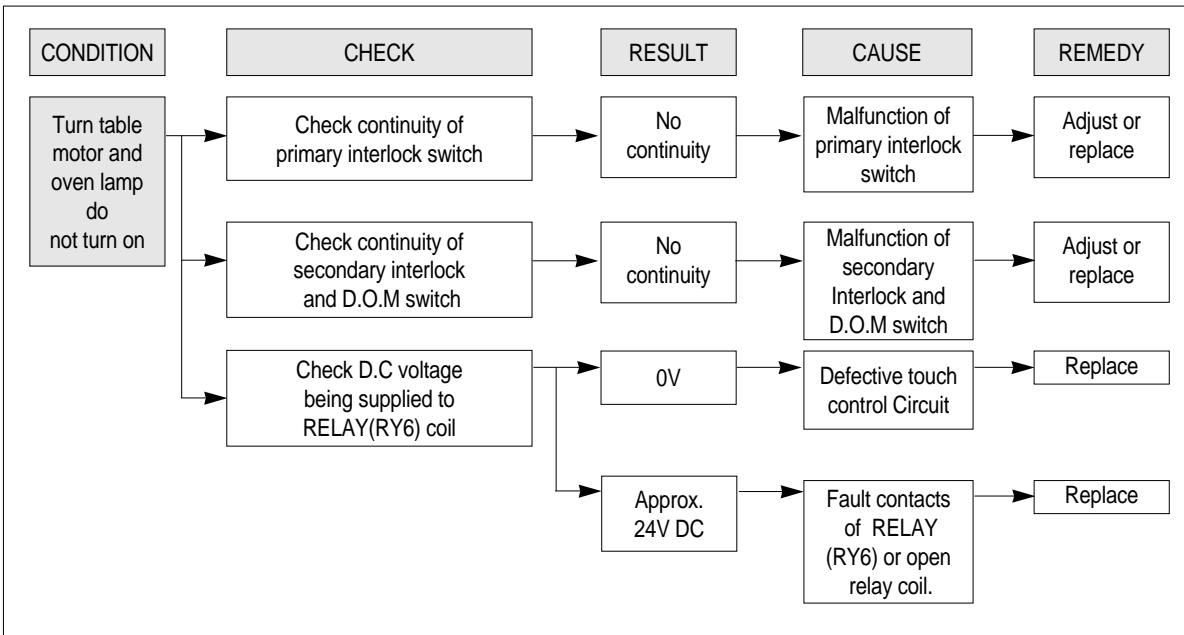

TROUBLE 3) No microwave oscillation even though fan motor rotates.

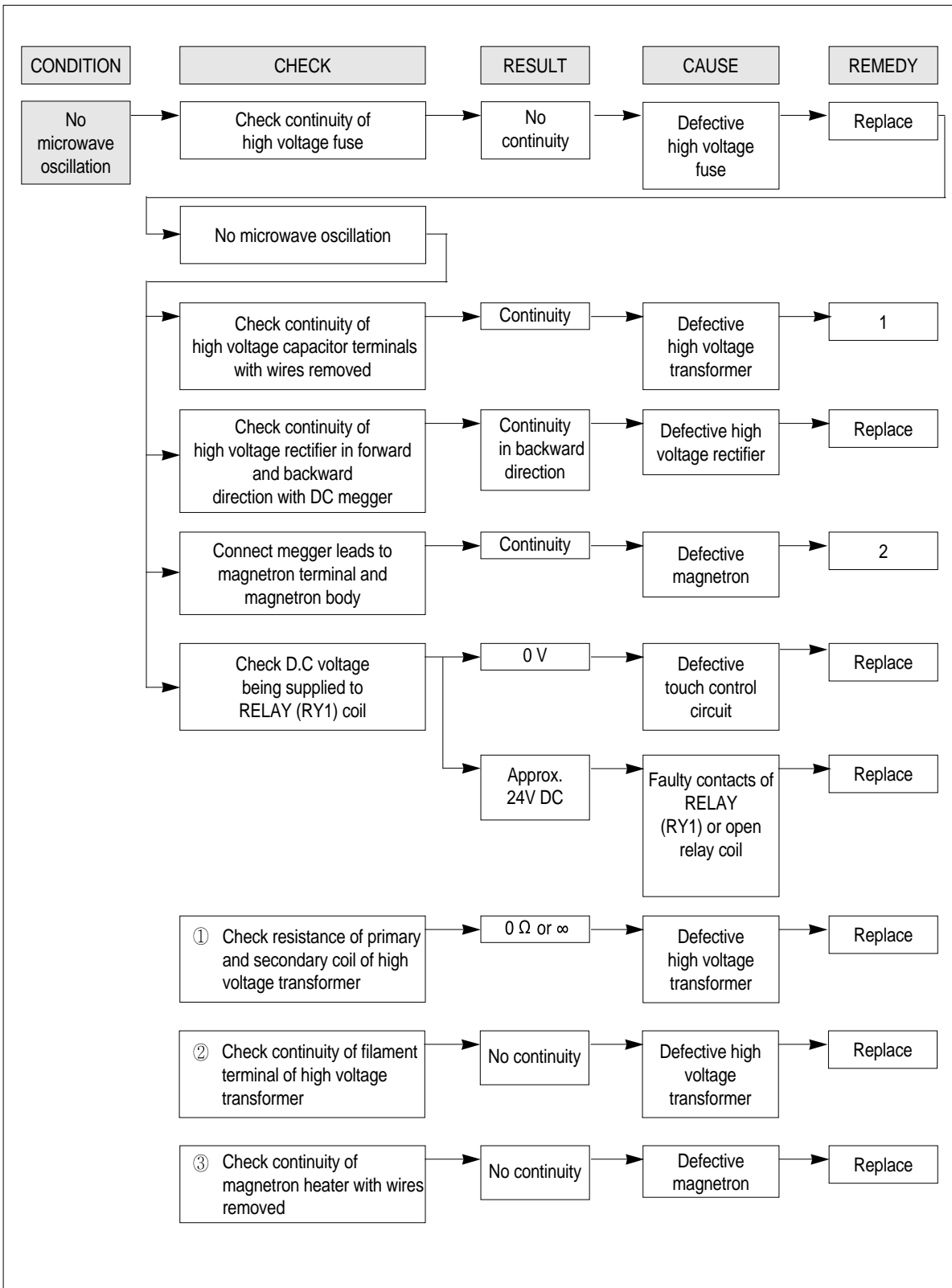

(TROUBLE 4)

Grill heater (upper heater) is not heated; food will not become hot.

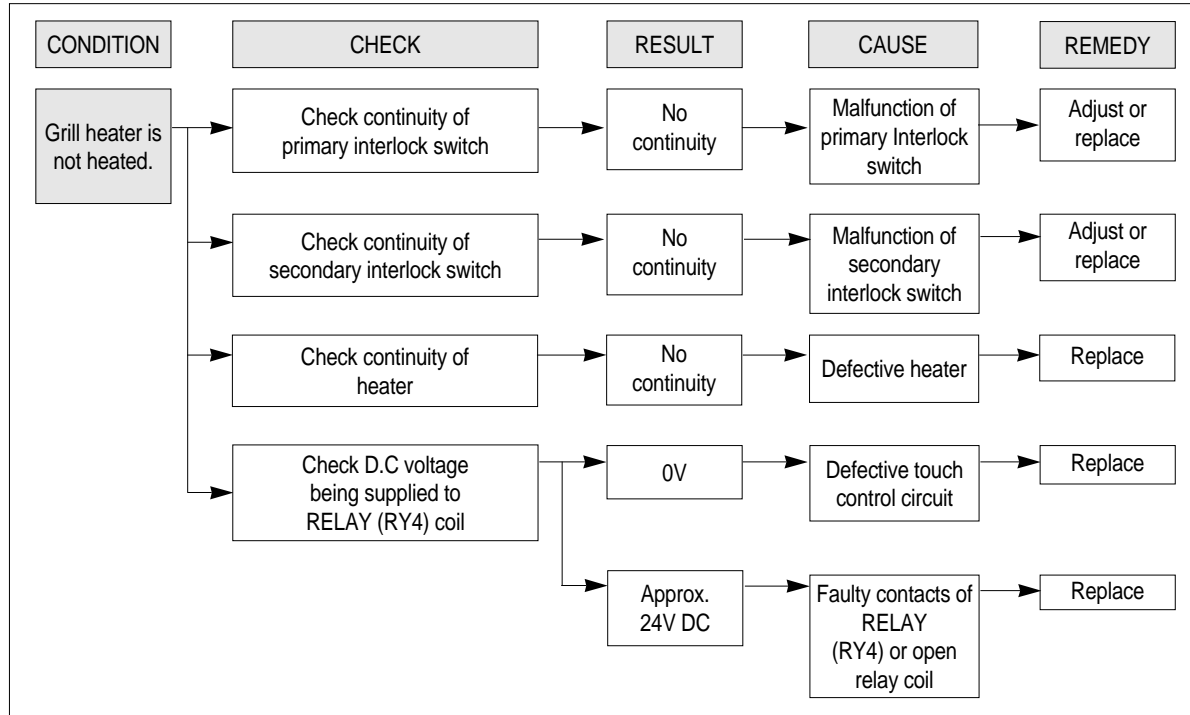

(TROUBLE 5)

1) Convection heater is not heated; food will not become hot.

2) Convection fan and motor does no rotate.

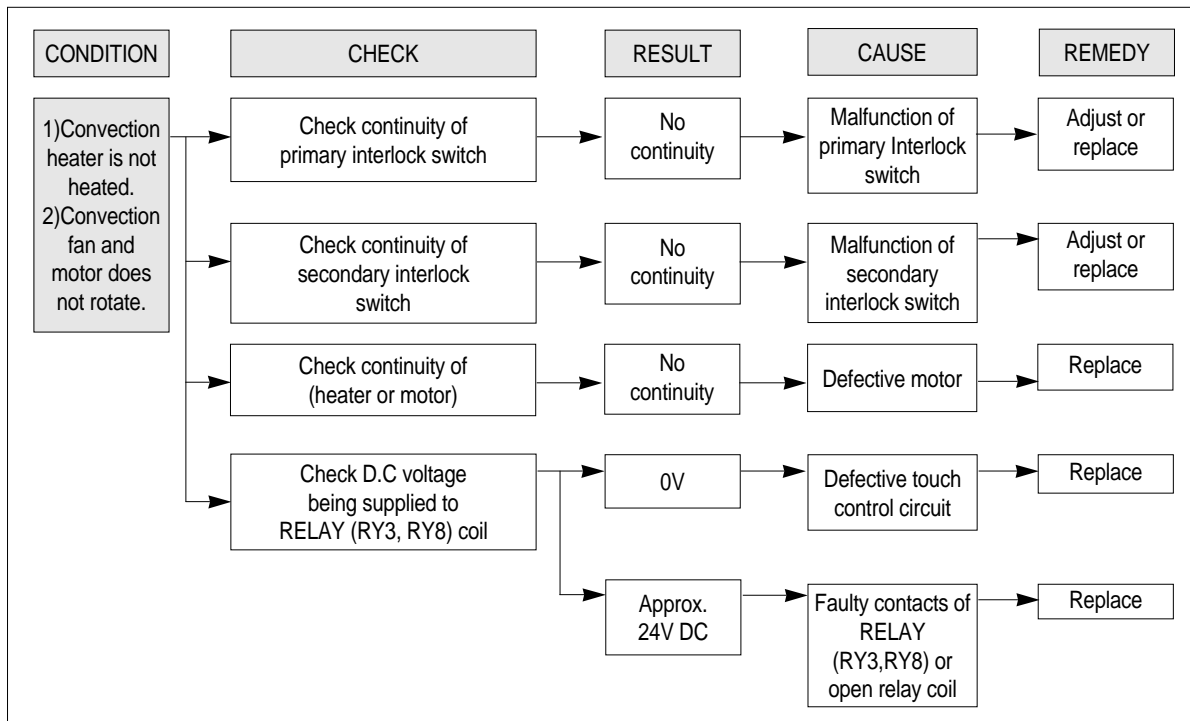

(TROUBLE 6)

Lower heater is not heated; food will not become hot.

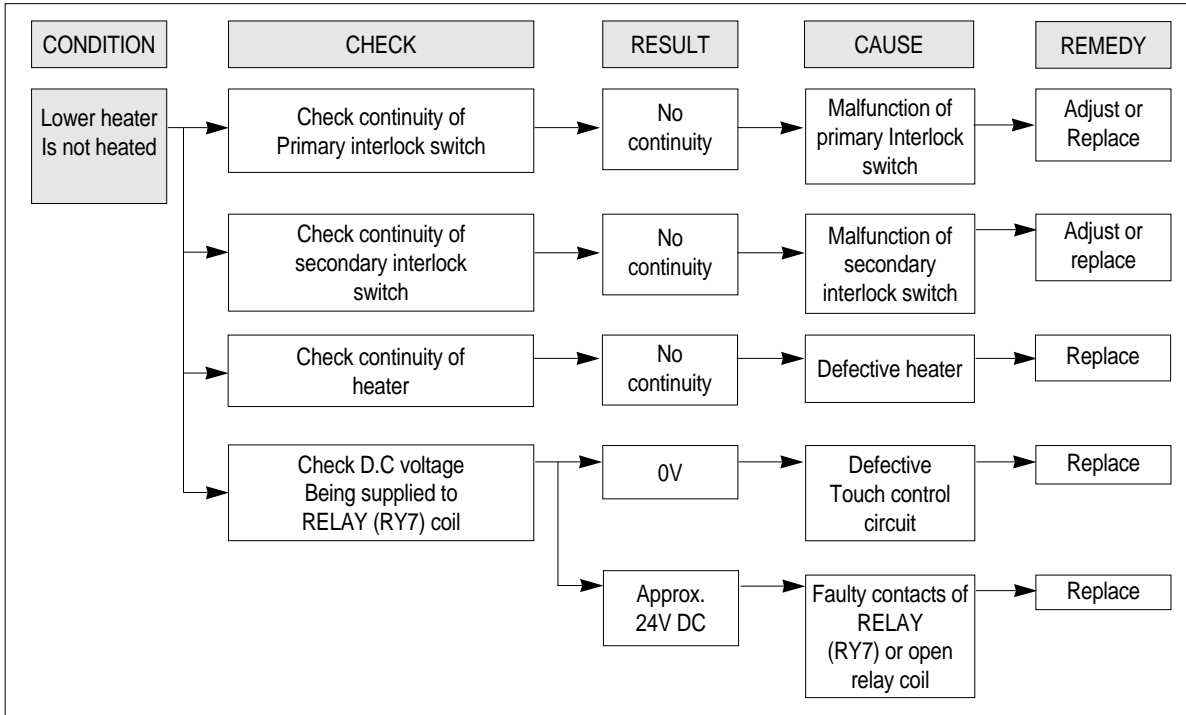

(TROUBLE 7)

The following visual conditions indicate a probable defective touch control Circuit or button P.C.B. assembly

1. Incomplete segments.
 - 1) segment missing
 - 2) partial segments missing
 - 3) digit flickering other than normal fluorescent slight flickering
2. A distinct change in the brightness of one or more numbers exists in the display.
3. One or more digits in the display are not on when they should be.
4. Display does not count down or up with time cooking or clock operation.
5. Oven is programmable and cooks normally but no display shows.
6. Display obviously jumps in time while counting down.
7. Display counts down noticeably too fast while cooking.
8. Display does not show the time of day when clear button is touched.
9. Oven lamp and turn table motor do not stop although cooking is finished.
Check if the RELAY(RY4) contacts close and if they are close, replace touch control circuit.

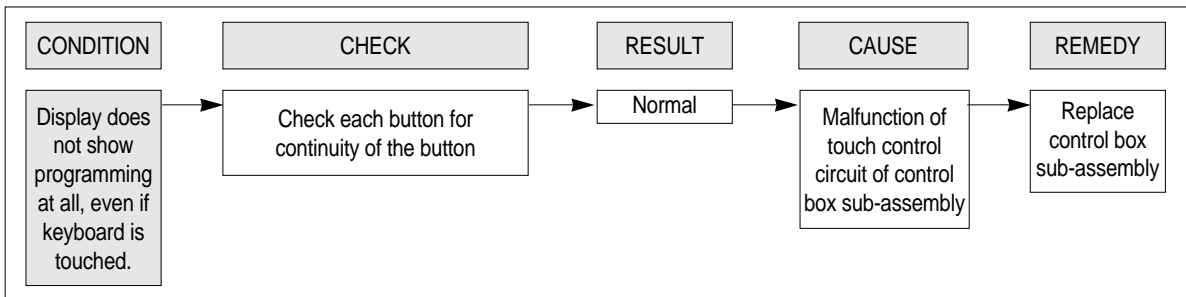
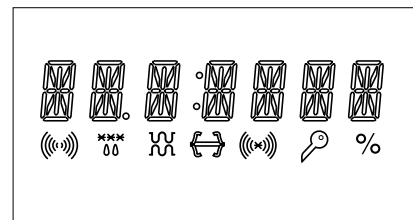

(TROUBLE 8)

When "ERROR 2 ERROR 3" come on display.

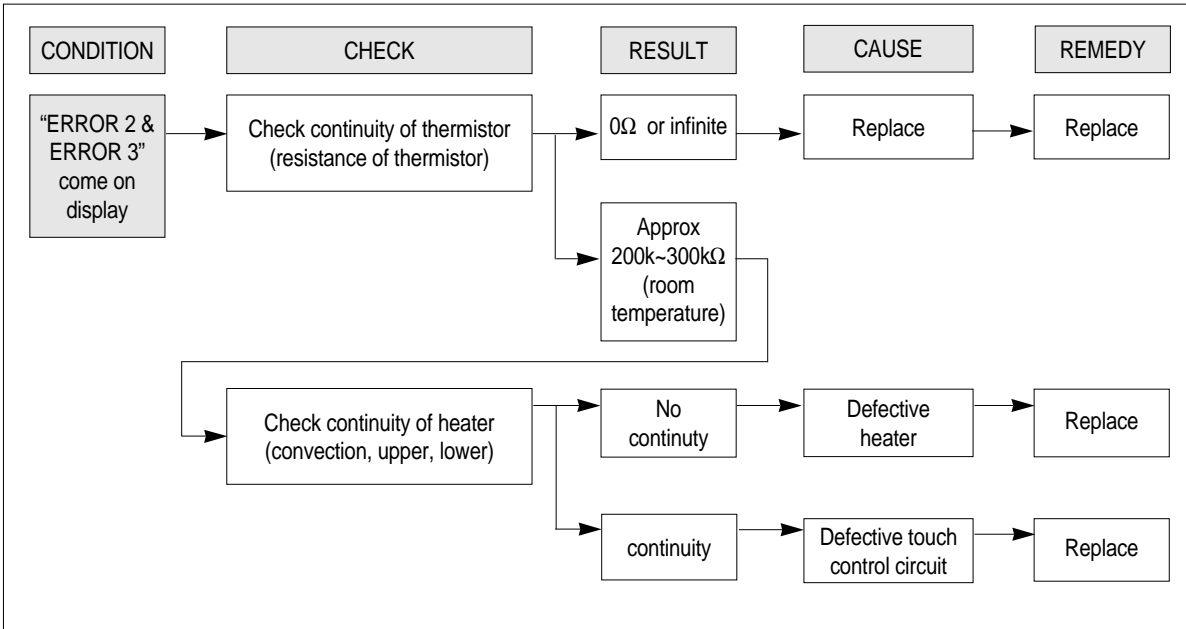

9. MEASUREMENT AND TEST

9-1. MEASUREMENT OF THE MICROWAVE POWER OUTPUT

Microwave output power can be checked by indirectly measuring the temperature rise of a certain amount of water exposed to the microwave as directed below.

PROCEDURE

- Microwave power output measurement is made with the microwave oven supplied at rated voltage and operated at its maximum microwave power setting with a load of 1000 ± 5 cc of potable water.
- The water is contained in a cylindrical borosilicate glass vessel having a maximum material thickness of 3 mm and an outside diameter of approximately 190 mm.
- The oven and the empty vessel are at ambient temperature prior to the start of the test. The initial temperature of the water is $10 \pm 2^\circ\text{C}$ ($50 \pm 3.6^\circ\text{F}$). It is measured immediately before the water is added to the vessel. After addition of the water to the vessel, the load is immediately placed on the center of the shelf, which is in the lowest normal position.
- Microwave power is switched on.
- Heating time should be exactly A seconds.
(Refer to table as following)
Heating time is measured while the microwave generator is operating at full power. The filament heat-up time for magnetron is not included.
- The initial and final temperature of water is selected so that the maximum difference between the ambient and final water temperature is 5K.
- The microwave power output P in watts is calculated from the following formula:

$$P = 4187 \times \Delta T/t$$

- ΔT is difference between initial and ending temperature.
- t is the heating time.

The power measured should be B (Refer to 2. SPECIFICATIONS) $W \pm 10.0\%$.

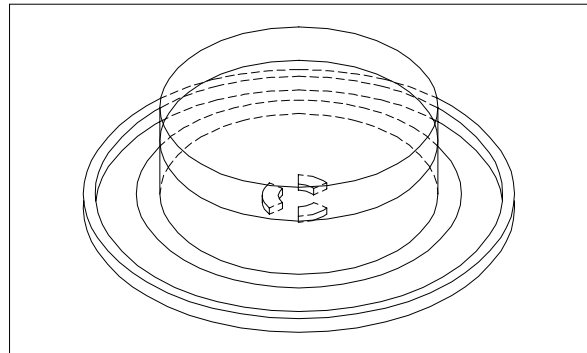

CAUTION

- Water load should be measured exactly to 1 liters.
- Input power voltage should be exactly specified voltage (Refer to 2. SPECIFICATIONS).
- Ambient temperature should be $20 \pm 2^\circ\text{C}$ ($68 \pm 3.6^\circ\text{F}$)

* Heating time for power output:

A (second)	70	64	60	56	52	49	47	44	42	40	38
B (W)	600	650	700	750	800	850	900	950	1000	1050	1100

9-2. MICROWAVE RADIATION TEST

WARNING

1. Make sure to check the microwave leakage before and after repair of adjustment.
2. Always start measuring of an unknown field to assure safety for operating personnel from microwave energy.
3. Do not place your hands into any suspected microwave radiation field unless the safe density level is known.
4. Care should be taken not to place the eyes in direct line with the source of microwave energy.
5. Slowly approach the unit under test until the radiometer reads an appreciable microwave leakage from the unit under the test.

PROCEDURE

1. Prepare Microwave Energy Survey Meter, 600cc glass beaker, and glass thermometer 100°C (212°F).
2. Pour 275cc \pm 15cc of tap water initially at 20 \pm 5°C (68 \pm 9°F) in the 600 cc glass beaker with an inside diameter of approx. 95 mm(3.5 in.).
3. Place it at the center of the tray and set it in a cavity.
4. Close the door and operate the oven.
5. Measure the leakage by using Microwave Energy Survey Meter with dual ranges, set to 2450MHz.
 - 1) Measured radiation leakage must not exceed the value prescribed below. Leakage for a fully assembled oven with door normally closed must be less than 4mW/Cm².
 - 2) When measuring the leakage, always use the 5 cm (2 in.) space cone with probe. Hold the probe perpendicular to the cabinet and door. Place the space cone of the probe on the door, cabinet, door seem, door viewing screen, the exhaust air vents and the suction air vents.
 - 3) Measuring should be in a counter-clockwise direction at a rate of 1 in./sec. If the leakage of the cabinet door seem is unknown, move the probe more slowly.
 - 4) When measuring near a corner of the door, keep the probe perpendicular to the areas making sure the probe end at the base of the cone does not get closer than 2 in. from any metal. If it does not, erroneous reading may result.

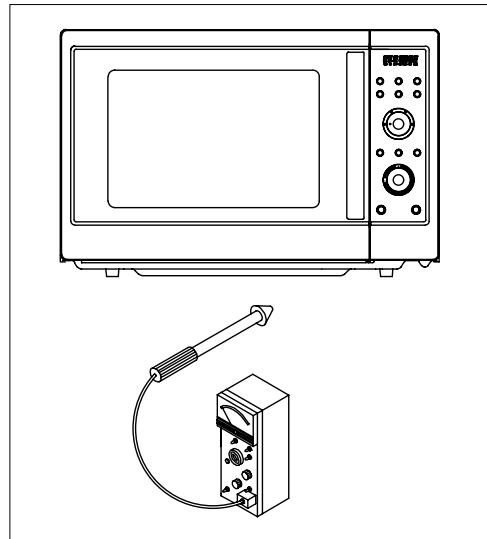

9-3. COMPONENT TEST PROCEDURE

- High voltage is present at the high voltage terminal of the high voltage transformer during any cooking cycle.
- It is neither necessary nor advisable to attempt measurement of the high voltage.
- Before touching any oven components or wiring, always unplug the oven from its power source and discharge the capacitor.

1. High voltage transformer

- 1) Remove connections from the transformer terminals and check continuity.
- 2) Normal readings should be as follows :
 - Secondary winding ... Approx. $100 \Omega \pm 10\%$
 - Filament winding ... Approx. 0.1Ω
 - Primary winding ... Approx. 1.4Ω

2. High voltage capacitor

- 1) Check continuity of capacitor with meter on the highest OHM scale.
- 2) A normal capacitor will show continuity for a short time, and then indicate 10M Ω once the capacitor charged.
- 3) A shorted capacitor will show continuous continuity.
- 4) An open capacitor will show constant 10M Ω .
- 5) Resistance between each terminal and chassis should be infinite.

3. High voltage diode

- 1) Isolate the diode from the circuit by disconnecting the leads.
- 2) With the ohmmeter set on the highest resistance scale measure the resistance across the diode terminals.
Reverse the meter leads and again observe the resistance reading. Meter with 500V dc or higher voltage batteries should be used to check the front-back resistance of the diode, otherwise an infinite resistance may be read in both directions. A normal diode's resistance will be infinite in one direction and several hundred k Ω in the other direction.

4. Magnetron

For complete magnetron diagnosis, refer to "Measurement of the Microwave Output Power." Continuity checks can only indicate an open filament or a shorted magnetron. To diagnose for an open filament or a shorted magnetron,

- 1) Isolate magnetron from the circuit by disconnecting the leads.
- 2) A continuity check across magnetron filament terminals should indicate 0.1Ω or less.
- 3) A continuity check between each filament terminal and magnetron case should read open.

5. Fuse

If the fuse in the primary and monitor switch circuit is blown when the door is opened, check the primary and monitor switch before replacing the blown fuse. In case the fuse is blown by an improper switch operation, replace the defective switch and fuse at the same time. Replace just the fuse if the switches operate normally.

9-4. COMPONENT ACTION

COOKING MODE		MAGNE-TRON	UPPER ELEMENT	LOWER ELEMENT	REAR ELEMENT	CONVECTION FAN
MANUAL MODE	M/W	●				
	GRILL-1		●			●
	GRILL-2		●	●		●
	COMBI-1	●		●	●	●
	COMBI-2	●		●	●	●
	COMBI-3		●	●	●	●
	COMBI-4	●	●			●
	COMBI-5	●	●	●		●
	CONVECTION40				●	●
	CONVECTION100~250		●	●	●	●
ONE TOUCH (CRUSTY/CAKE)	FRESH PIZZA	●	●	●	●	●
	FROZEN PIZZA	●	●	●		●
	FRESH GRATIN	●	●		●	●
	FROZEN GRATIN	●	●		●	●
	CAKE	●	●	●	●	●
	BREAD	●	●	●	●	●
AUTO COOK MODE	ROAST BEEF	●	●	●	●	●
	ROAST CHICKEN	●	●	●	●	●
	ROAST PORK	●	●	●	●	●
	BAKED FISH	●	●		●	●
	BAKED POTATO	●	●		●	●
	ROAST POTATO	●	●		●	●
	FRESH VEGETABLES	●				
	FROZEN VEGETABLES	●				
	CASSEROLE	●				

10. WIRING DIAGRAM

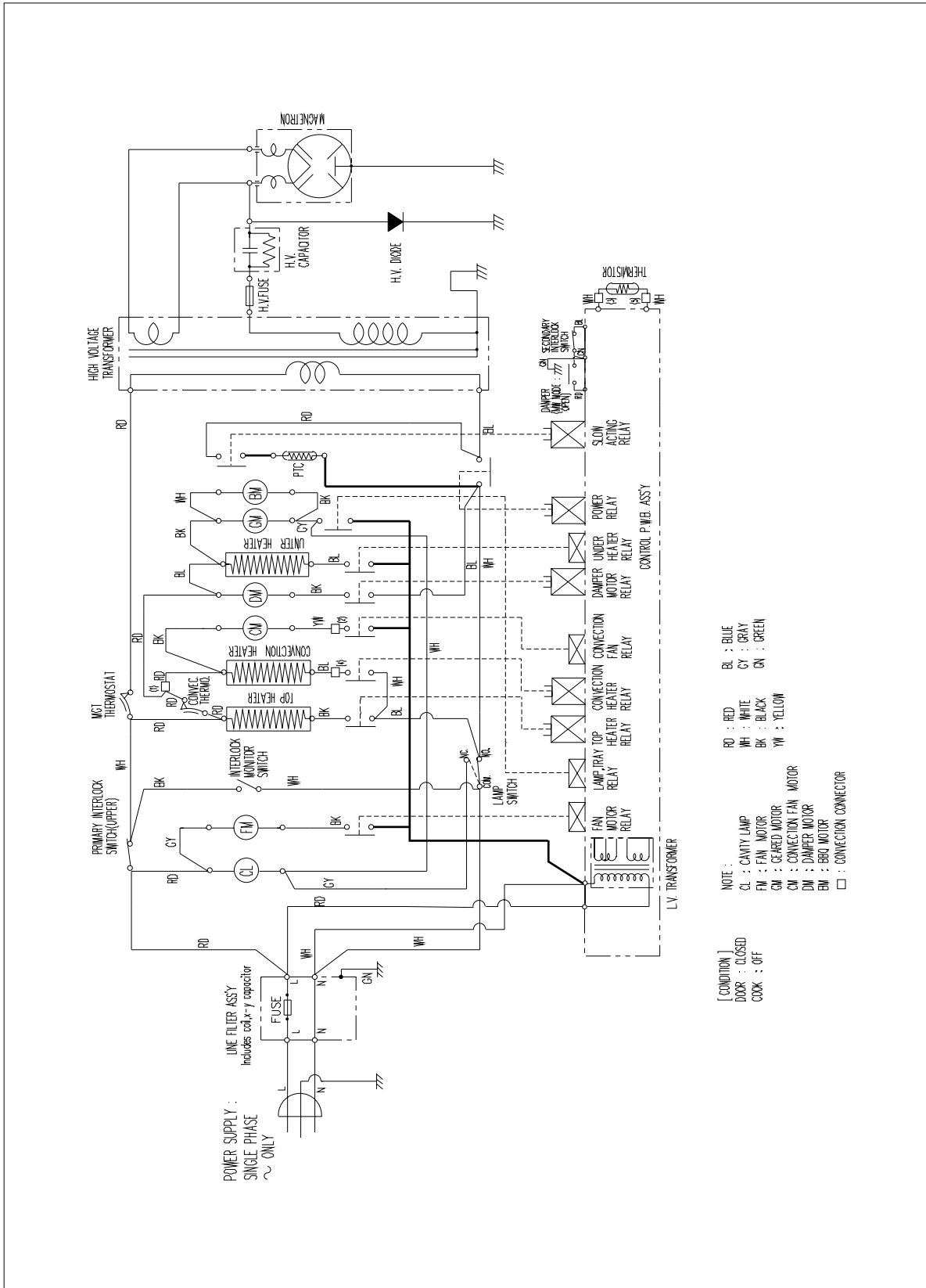

11. EXPLODED VIEW AND PARTS LIST

TOTAL ASSEMBLY

* From A00 to G00 and P00, refer to 6. Disassembly and assembly.

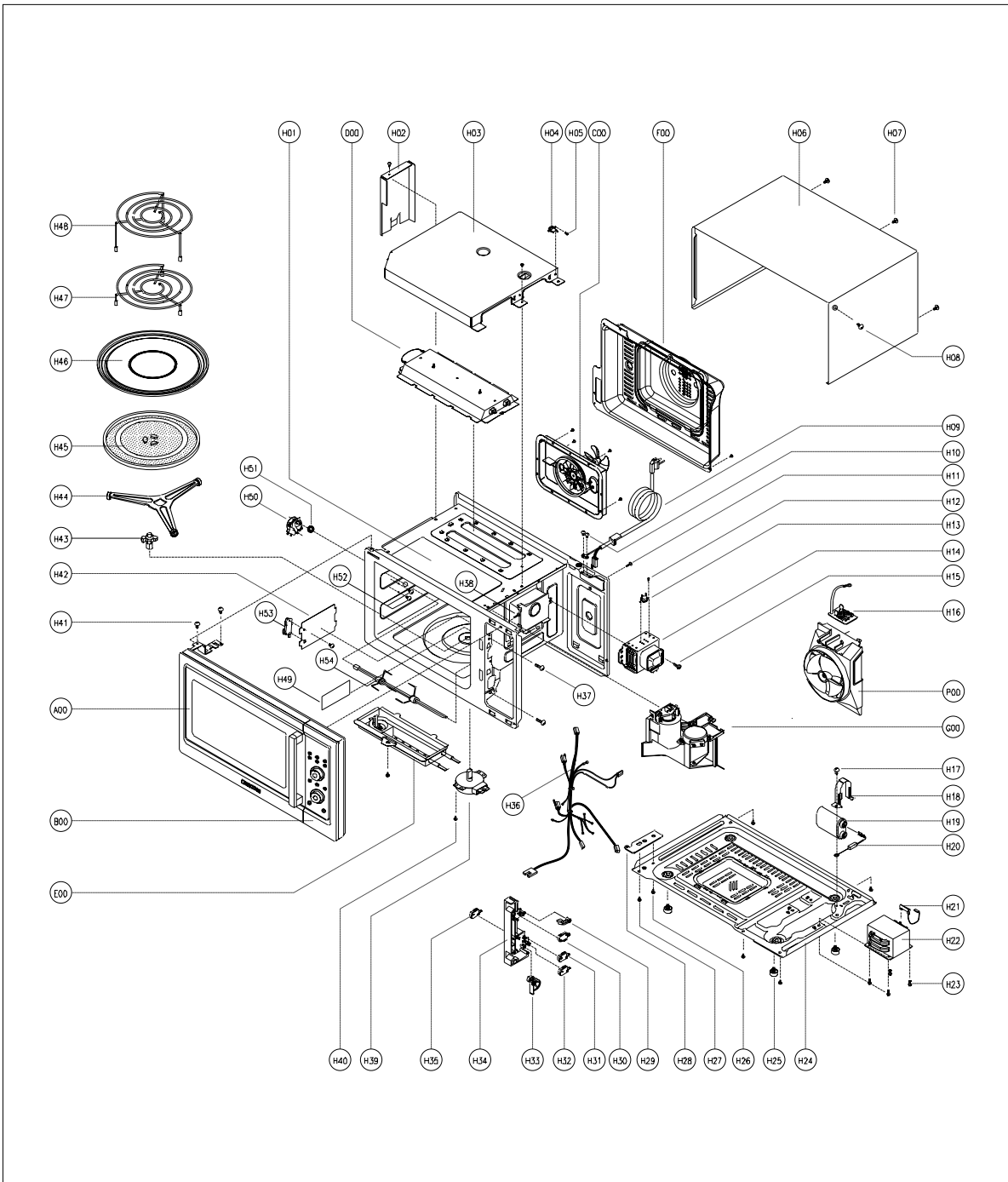

NO	PARTS CODE	PARTS NAME	DESCRIPTION	Q'TY	REMARK
A00	3511724960	DOOR AS	KOC-154K8S	1	
B00	PKCPSWF240	CONTROL-PANEL AS	KOC-154K8SA2	1	
C00	3512804140	HEATER *B AS	KOC-154K8S	1	
D00	3512804030	HEATER *T AS	KOC-154K8S	1	
E00	3512803900	HEATER *U AS	KOC-1B0K0S	1	
F00	3511408520	COVER *B AS	KOC-154K8S	1	
G00	3512525310	GUIDE AIR AS	KOC-154K8S	1	
P00	3512513400	GUIDE WIND AS	KOC-971C0S	1	
H01	3516117720	CAVITY AS	KOC-154K8SA2	1	
H02	3512523600	GUIDE AIR OUTLET	SBHG T0.5	1	
H03	3513304000	INSULATOR HEATER *T	SECC TO.5	1	
H04	7121400611	SCREW TAPPING	T2S PAN 4X6	1	
H05	3518904400	THERMOSTAT	OFF:120 ON:60 VN	1	
H06	3510808620	CABINET AS	KOC-154K8S	1	
H07	7112401011	SCREW TAPPING	T1 TRS 4X10	4	
H08	7112401012	SCREW TAPPING	T1 TRS 4X10 BK	1	
H09	35113A5QJ5	CORD POWER AS	3X1.5 80X80 120-RTML 1.4M	1	
H10	7S432X4081	SPECIAL SCREW	TT3 TRS 4X8 SE MFZN	2	
H11	7122401211	SCREW TAPPING	T2S TRS 4X12	1	
H12	7121300811	SCREW TAPPING	T2S PAN 3X8	1	
H13	3518903400	THERMOSTAT	OFF:150 ON:60 V	1	
H14	3518003700	MAGNETRON	2M218JFL 6CF	1	
H15	3516004000	SPECIAL SCREW	T2 BOLT FLANGE 5X12	1	
H16	3518605001	NOISE-FILTER	DWLF-M05	1	
H17	7S432X4081	SPECIAL SCREW	TT3 TRS 4X8 SE MFZN	1	
H18	3513003200	HOLDER HV CAPACITOR	SECC T0.6	1	
H19	3518302301	CAPACITOR HV	2100VAC 1.10UF #187 80MM	1	
H20	3518400400	DIODE HV	HVR-1X-3AB 12KV #187	1	
H21	3518701400	FUSE HV	5KV 0.7A	1	
H22	3518119110	TRANS HV	RIS5DA	1	
H23	7147401011	SCREW TAPPING	T2 FLANGE 4X10	4	
H24	3510317300	BASE	SBHG -1 TO.8	1	
H25	3512101400	FOOT	DASF-310	4	
H26	7272400811	SPECIAL SCREW	TT3 TRS 4X8 MFZN	1	
H27	7112401011	SCREW TAPPING	T1 TRS 4X10	6	
H28	3515202800	STOPPER HINGE *U AS	KOR-121M0A	1	
H29	3513702100	LEVER SW MICRO	POM,KOG-846T0S	1	
H30	4415A17352	SW MICRO	VP-533A-OF SPNO #187	1	
H31	4415A66600	SW MICRO	VP-532A-OF SPNC #187	1	
H32	4415A17352	SW MICRO	VP-533A-OF SPNO #187	1	
H33	3513700800	LEVER LOCK	POM	1	
H34	3513820000	LOCK	PP	1	
H35	4415A66910	SW MICRO	VP-531A-OF	1	
H36	3512718450	HARNES MAIN	KOC-154K8SA2	1	
H37	7122401211	SCREW TAPPING	T2S TRS 4X12	1	
H38	7122401211	SCREW TAPPING	T2S TRS 4X12	1	
H39	3966031110	MOTOR SYNCRO	220/240V 50/60 SM16	1	
H40	7121400611	SCREW TAPPING	T2S PAN 4X6	1	
H41	3516003700	SPECIAL SCREW	TT3 HEX 4X8 FLG MFZN	2	
H42	3511408310	COVER WAVE GUIDE	KOC-154K8SA2	1	
H43	3517402500	COUPLER	PTFE	1	
H44	3512521000	GUIDE ROLLER AS	KOC-1B0K0S	1	
H45	3517207600	TRAY	DIA:340 1300G	1	
H46	3517211100	TRAY METAL AS	KOC-1B0K0S	1	
H47	3517207330	TRAY RACK AS	KOC-154K8S 50MM	1	
H48	3517207320	TRAY RACK AS	KOC-154K8S 160MM	1	
H49	3511411500	COVER LAMP	PE	1	
H50	3966830910	MOTOR SYNCRO	SSM-23H	1	
H51	3512300301	GASKET	C2700W T1.0	1	
H52	7113400814	SCREW TAPPING	T1 BIN 4X8 MFNI	2	
H53	3512521200	GVIDE ROTARY	TEFRON	1	
H54	3517605510	UTENSIL BAR AS	KOC-154K8SA2	1	

12. PRINTED CIRCUIT BOARD

CIRCUIT CHECK PROCEDURE

1. Low voltage transformer check

The low voltage transformer is located on the P.C.B.

Measuring condition: Input voltage: 220~240V / Frequency: 50Hz

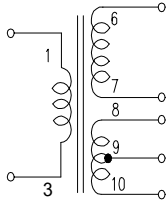

Terminal	Voltage(load)	Voltage(no load)
6-7	AC 17.0 V	AC 19.9 V
8-9	AC 1.3 V	AC 1.6 V
9-10	AC 1.3 V	AC 1.6 V

NOTE

1. Secondary side voltage of the low voltage transformer changes in proportion to fluctuation of power source voltage.
2. The allowable tolerance of the secondary voltage is within $\pm 5\%$ of nominal voltage.

2. Voltage Check

- Key check point

NO	CHECK POINT	REMARK
1	IC1 PIN 63, 64	5VDC \pm 5%
2	IC1 PIN 38	<p>T : 20 ms(50Hz)</p>
3	IC1 PIN 33 OR 34	<p>T : 250 ns(4MHz)</p>

- Check method

NO	MEASURE POINT	WAVE FORM	REMEDY	REMARK
1	A	DC 5V \pm 5%	Replace ZD2, EC1	NO LOAD
2	B	DC 24V \pm 20%	Replace D23-26, EC4	NO LOAD

NOTE: Each measure point must be measured with GND points.

3. Case of no microwave oscillation

1) When touching M/W button, oven lamp turns on and Fan motor and turntable rotate, and cook indicator in display comes on.

*Cause: **RELAY 1** does not operate.

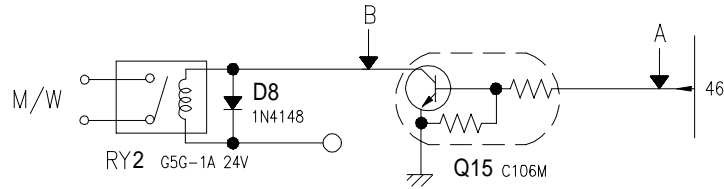

- Check method

STATE	POINT A	POINT B
RELAY 1 ON	+5V DC	GND
RELAY 1 OFF	GND	+24V DC

2) When touching M/W button, oven lamp does not turn on and turntable motor does not rotate but cook indicator in display comes on.

*Cause: **RELAY 6** does not operate.

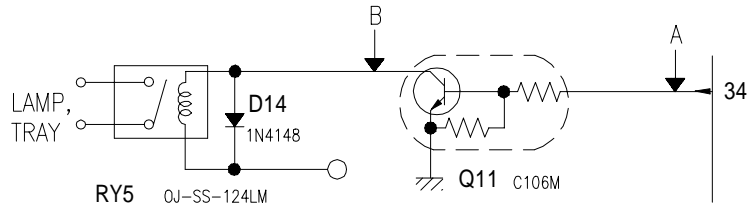

- Check method

STATE	POINT A	POINT B
RELAY 6 ON	+5V DC	GND
RELAY 6 OFF	GND	+24V DC

3) When touching M/W button, oven lamp turns on and fan motor does not rotate but cook indicator in display comes on.

*Cause: **RELAY 7** does not operate.

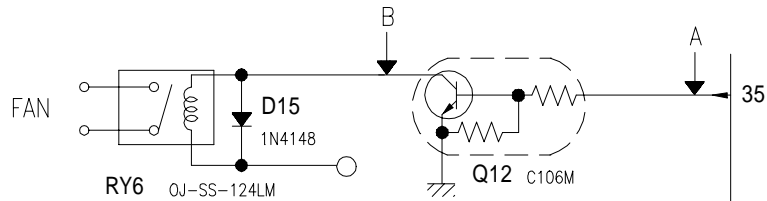

- Check method

STATE	POINT A	POINT B
RELAY 7 ON	+5V DC	GND
RELAY 7 OFF	GND	+24V DC

4. Case of no heating of upper grill

When touching GRILL1 & COMBI button, oven lamp turns on and Fan motor and turntable motor rotate and cook indicator in the display comes on.

*Cause: **RELAY 4** does not operate.

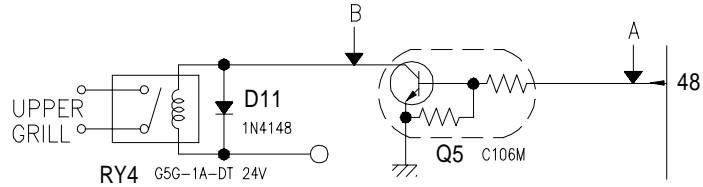

STATE	POINT A	POINT B
RELAY 4 ON	+5V DC	GND
RELAY 4 OFF	GND	+24V DC

5. Case of no heating of lower grill

When touching GRILL2 & COMBI button, oven lamp turns on and Fan motor and turntable motor rotate and cook indicator in display comes on.

*Cause: **RELAY 9** does not operate.

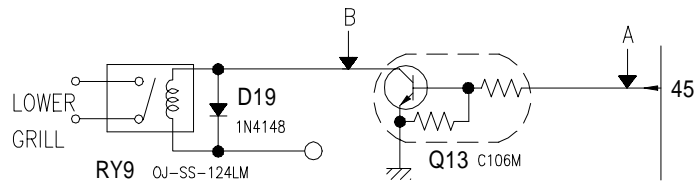

STATE	POINT A	POINT B
RELAY 9 ON	+5V DC	GND
RELAY 9 OFF	GND	+24V DC

6. Case of no heating of convection grill

When touching CONVECTION button, oven lamp turns on and Fan motor and turntable motor rotate and cook indicator in the display comes on.

*Cause: **RELAY 3** does not operate.

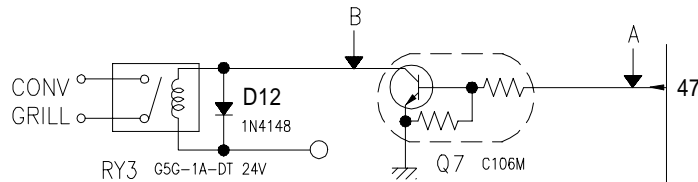

STATE	POINT A	POINT B
RELAY 3 ON	+5V DC	GND
RELAY 3 OFF	GND	+24V DC

7. Case of no stopping of the count down timer

When the door is opened during operation, the count down timer does not stop.

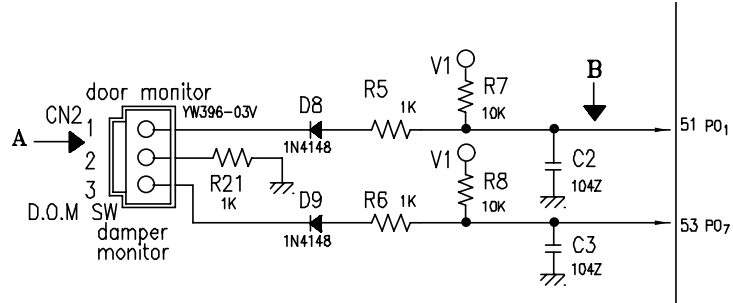

- Check method

STATE \ POINT	A	B
DOOR OPEN	OPEN	+5V DC
DOOR CLOSED	CLOSE	GND

CHECK NO	METHOD	REMEDY
1	Check the stage(ON,OFF) of the door open monitor switch by resistance measurement.	Replace door open monitor swith.

NO	NAME	LOCATION	PART CODE	SPECIFICATION	Q'TY	REMARK
1	BUZZER	BZ1	3515600100	BM-20K	1	
2	C CERA	C1-4,7~13	CCZF1H104Z	50V HIKF 0.1uF Z	11	
3	C CERA	C5,6	CCZB1H102K	50V B 1000pF K	2	
4	C ELECTRO	EC1	CEXE1H100A	50V RS 10uF (5X11) TP	1	
5	C ELECTRO	EC2,EC3	CEXF1V221V	35V RSS 220uF (10X12.5) TP	2	
6	C ELECTRO	EC4	CEXF1V102V	35V RSS 1000uF (13X25) TP	1	
7	C ELECTRO	EC5	CEXF1H101V	50V RSS 100uF (8X11.5) TP	1	
8	C ELECTRO	EC6	CEXF1H221V	50V RSS 220uF (10X16) TP	1	
9	CONN WAFER	CN2	3519150530	YW396-03V	1	
10	CONN WAFER	CN1	30166M5030	35312-0310	1	
11	CONN FILM	CN3	4CW215SBD0	HLEM15S-1	1	
12	CONN WAFER	CN4	3519150700	YW396-11AV	1	
13	DIODE SWITCHING	D1~20	DZN4148---	1N4148 AUTO 52mm	20	
14	DIODE RECTIFIER	D21~D26	DZN4004A--	1N4004A AUTO 52mm	6	
15	DIODE ZENER	ZD1	DZUZ3R3BSB	UZ-3.3BSB	1	
16	DIODE ZENER	ZD3	DZUZ24BSB-	UZ-24BSB	1	
17	DIODE ZENER	ZD2	DZUZ5R6BSB	UZ-5.6BSB	1	
18	DIODE ZENER	ZD4	DZUZ13BSA-	UZ-13BSA	1	
19	DIODE ZENER	ZD5	DZUZ3R9BSB	UZ-3.9BSB	1	
20	DIGITRON	DP1	DHNM07MS12	HNM-07MS12	1	
21	FOAM	SPONGE	3517305500	40X15X5	1	
22	IC MICOM	IC1	13GL87P14N	TMP87PM14N(OTP)	1	
23	PCB MAIN	M279	3514330330	BOARD(97x257)	1	
24	PTC	PTC1	DP1390MK10	390M (39 OHM, 120°C)	1	
25	R CARBON FILM	R3	RD-AZ201J-	1/6 200 OHM 5%	1	
26	R CARBON FILM	R4-6,16,18-21,26,30	RD-AZ102J-	1/6 1K OHM 5%	10	
27	R CARBON FILM	R27	RD-AZ472J-	1/6 4.7K OHM 5%	1	
28	R CARBON FILM	R2,7-11,22~24	RD-AZ103J-	1/6 10K OHM 5%	9	
29	R CARBON FILM	R34	RD-AZ473J-	1/6 47K OHM 5%	1	
30	R CARBON FILM	R15,17,25	RD-AZ104J-	1/6 100K OHM 5%	3	
31	R CARBON FILM	R1	RD-AZ105J-	1/6 1M OHM 5%	1	
32	R CARBON FILM	R28	RD-4Z102J-	1/4 1K OHM 5%	1	
33	R CARBON FILM	R33	RD-2Z270JS	1/2 27 OHM 5% SMALL	1	
34	R CARBON FILM	R31,32	RD-2Z201JS	1/2 200 OHM 5% SMALL	2	
35	R CARBON FILM	R29	RD-2Z271JS	1/2 270 OHM 5% SMALL	1	
36	R METAL FILM	R13	RN-AZ1301F	1/6 1.3K OHM 1%	1	
37	R METAL FILM	R14	RN-AZ1692F	1/6 16.9K OHM 1%	1	
38	R METAL FILM	R12	RN-AZ1503F	1/6 150K OHM 1%	1	
39	R ARRAY	RA1	RA-85X104J	5P(4) 1/8 100K OHM 5%	1	
40	R ARRAY	RA2	RA-86X104J	6P(5) 1/8 100K OHM 5%	1	
41	RESONATOR CERA	CR1	5P4R00MTS-	CRT4.00MS	1	

NO	NAME	LOCATION	PART CODE	SPECIFICATION	Q'TY	REMARK
42	SW RELAY	RY1,2	5SC0101122	G5G-1A 1C 1P DC24V	2	
43	SW RELAY	RY3-5	5SC0101124	G5G-1A-DT 1C 1P DC24V	3	
44	SW RELAY	RY6-9	5SC0101129	CS11-24SH 1C 1P	4	
45	TR	Q5-8,10~14,17	TZRC106M--	KRC-106M (AUTO)	10	
46	TR	Q1,4	TZTA1266Y-	KTA-1266Y (AUTO) (1015Y)	2	
47	TR	Q2,3,9,16	TZTC3198GR	KTC-3198GR (AUTO) (1815GR)	4	
48	TR	Q15	TZTC1027Y-	KTC-1027Y	1	
49	TRANS POWER	LVT	5EPV041410	DMR-210FS	1	
50	WIRE COPPER	J10,11,13,15,16,18,20-22,S,J5	85801052GY	1/0.52 TIN COATING 7.5mm	10	
51	WIRE COPPER	J3,9	85801052GY	1/0.52 TIN COATING 15mm	2	
52	WIRE COPPER	J2,8,14	85801052GY	1/0.52 TIN COATING 12.5mm	3	
53	WIRE COPPER	J1,4-7,12,17,19	85801052GY	1/0.52 TIN COATING 10mm	8	
54	CONN WAFER	CN101	4CW215RBD0	HLEM15R-1	1	
55	PCB SUB	M280	3514322760	BOARD(81x231)	1	
56	SW ROTARY	EN101	5S10109002	SDB161PVB17F123636(P=5MM)	1	
57	VR ROTARY	VR101	5V1104103B	V012LPV20F 100K	1	
58	SW TACT	SW101~SW111	5S50101Z93	KPT-1115AM	11	
59	WIRE COPPER	J102	85801052GY	1/0.52 TIN COATING 10mm	1	
60	WIRE COPPER	J101	85801052GY	1/0.52 TIN COATING 7.5mm	1	
61	WIRE FLAT	WF1	WSJ-159007	1.25X15X90XC	1	



S/M NO. :

DAEWOO ELECTRONICS CORP.
686, AHYEON-DONG MAPO-GU SEOUL, KOREA
C.P.O. BOX 8003 SEOUL, KOREA
TELEX: DWELEC K28177-8
CABLE: "DAEWOOELEC"

PRINTED DATE: Feb. 2008