

KD-291R/291RC

SERVICE MANUAL

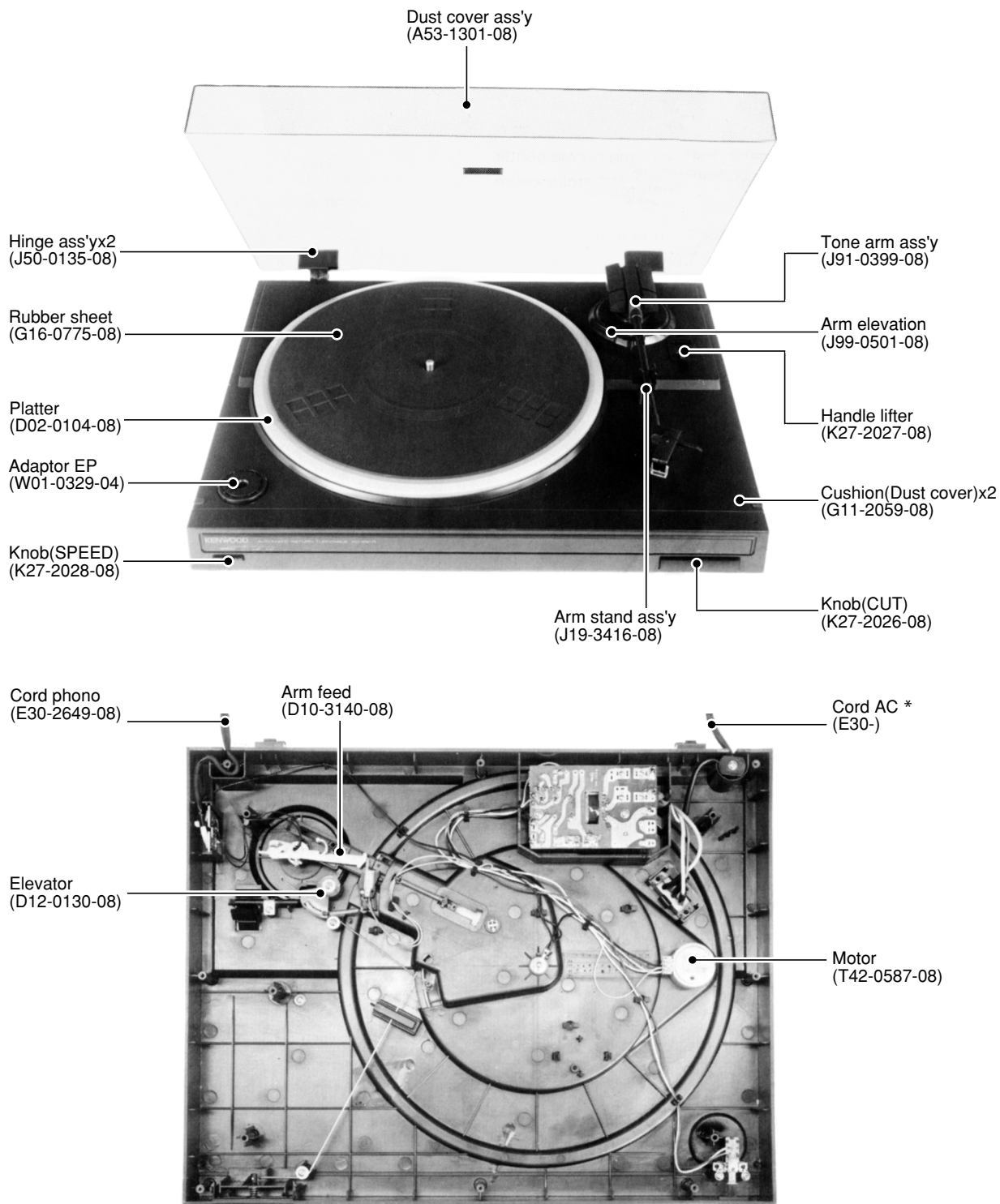

KD-291R/291RC

MECHANISM DESCRIPTION

Operation

1. Motor ON

When the tonearm is moved down on the surface of the record, the feed arm ❶ moves in the direction of an arrow so that SW2 turns ON to start the motor.

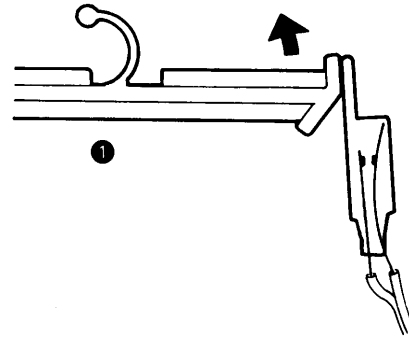

2. Tonearm Return

When the tonearm arrives at the end of the record, an operation as shown below is performed. Thus, the gear of the center shaft is engaged with the ring gear to start counterclockwise rotation.

By the ring gear ass'y alone, the tonearm actuator moves in the direction of arrows to return the tonearm.

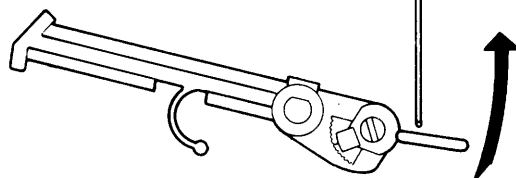
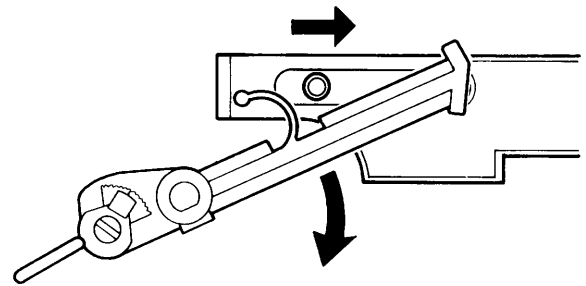
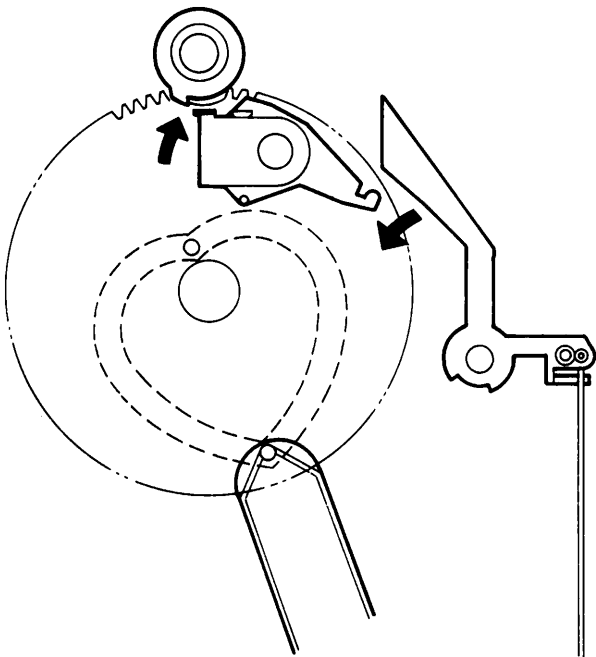

Same operation with arm

KD-291R/291RC

MECHANISM DESCRIPTION

3. Cueing

- a. For manual return, the lifter and the elevator work.
- b. For auto return, the tonearm actuator and the elevator work.

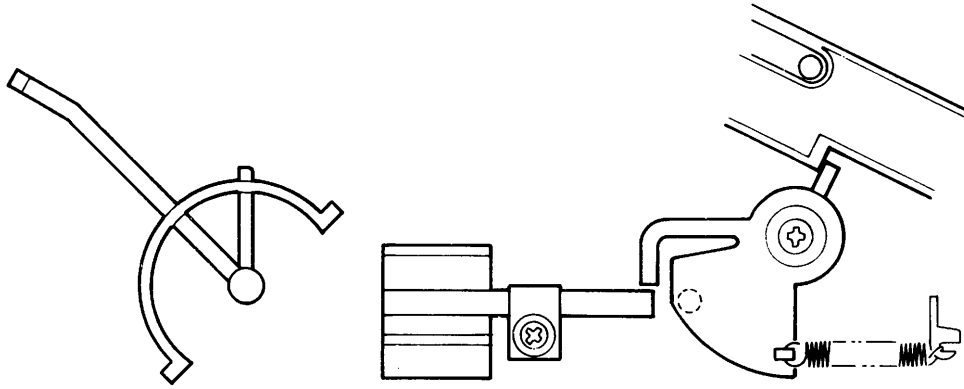

-- down --

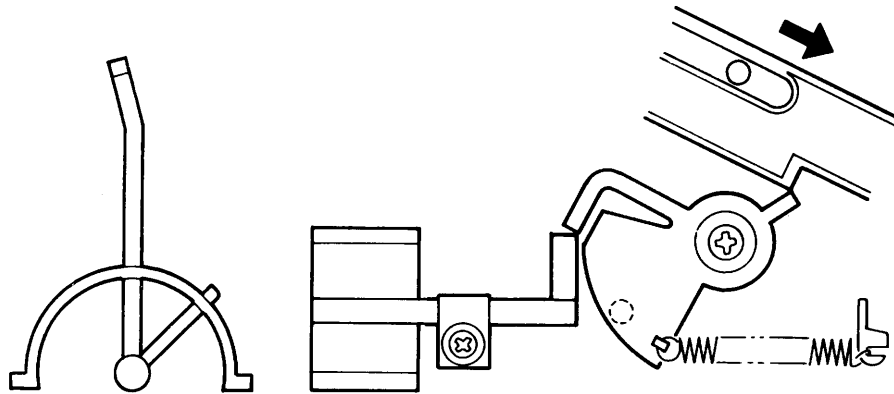

-- up --

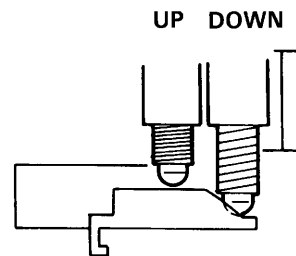

KD-291R/291RC

ADJUSTMENT / REGLAGES / ABGLEICH

ADJUSTMENT

1. Auto-return position adjustment

For this, adjust the cam as shown on the right.
(After adjustment, lock it.)

2. Speed adjustment

First, adjust the 33 RPM by VR1, then the 45 RPM by VR2.

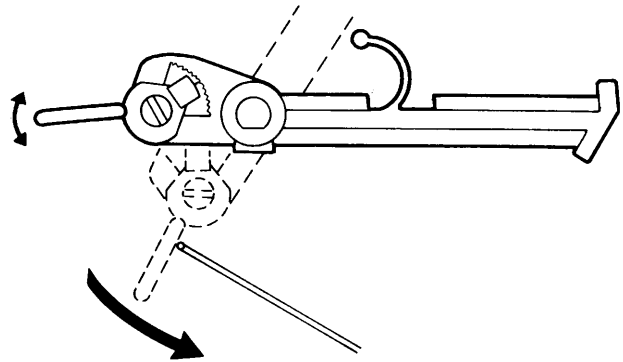

REGLAGES

1. Ajustement de la position de retour automatique

Pour ceci, ajuster la came comme indiqué sur la droite.
(Après l'ajustement, la verrouiller.)

2. Ajustement de la vitesse

D'abord ajuster les 33 tours avec RV1 puis les 45 tours avec RV2.

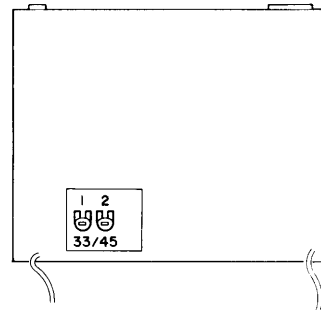

ABGLEICH

1. Einstellung der automatischen Rückkehrposition

Hierfür den Nocken wie rechts abgebildet einstellen.
(Nach der Einstellung arretieren.)

2. Drehzahl-Einstellung

Zuerst 33 Upm mit VR1 und dann 45 Upm mit VR2 einstellen.

PC BOARD (Component side view)

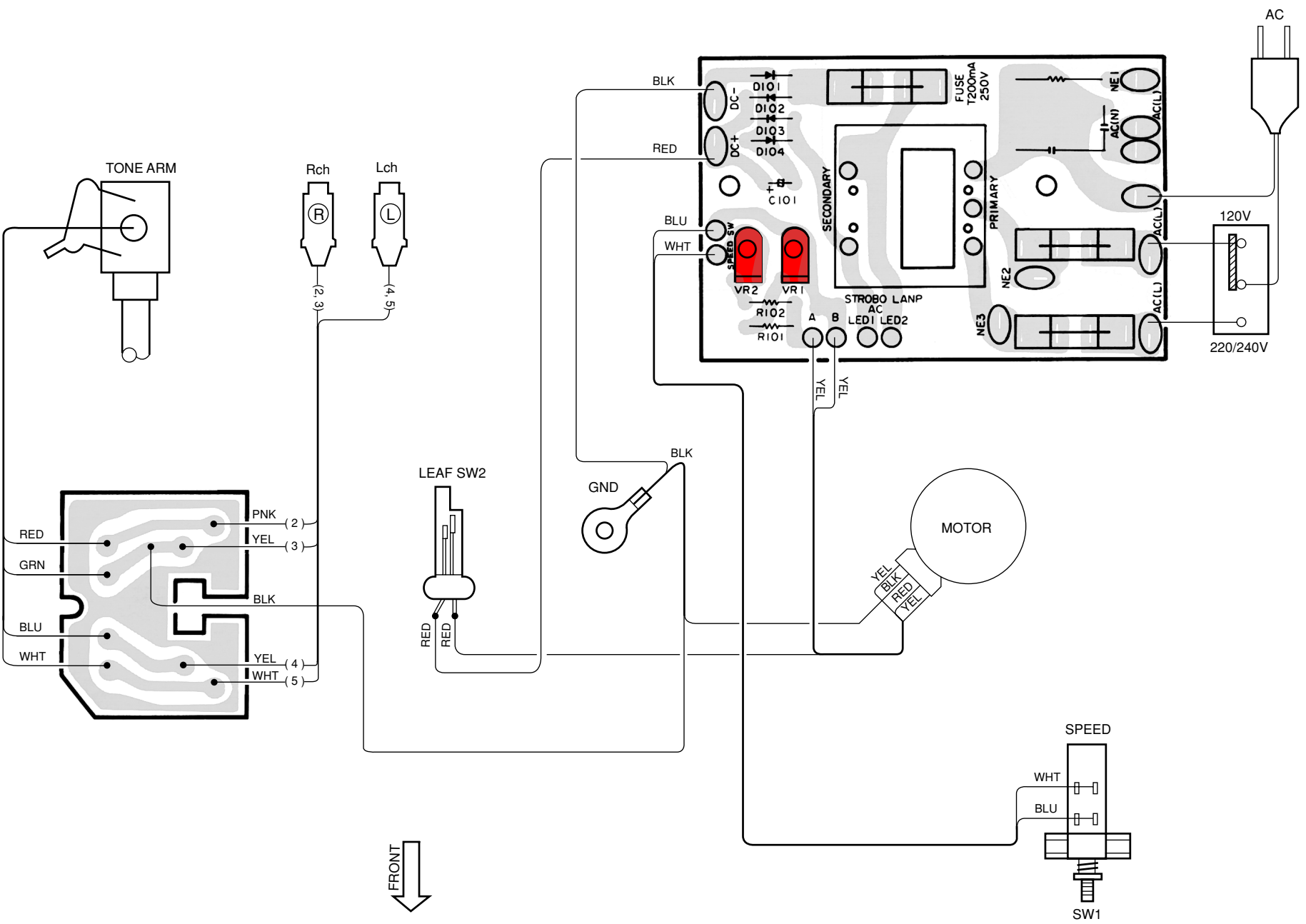

Refer to the schematic diagram for the value of resistors and capacitors.

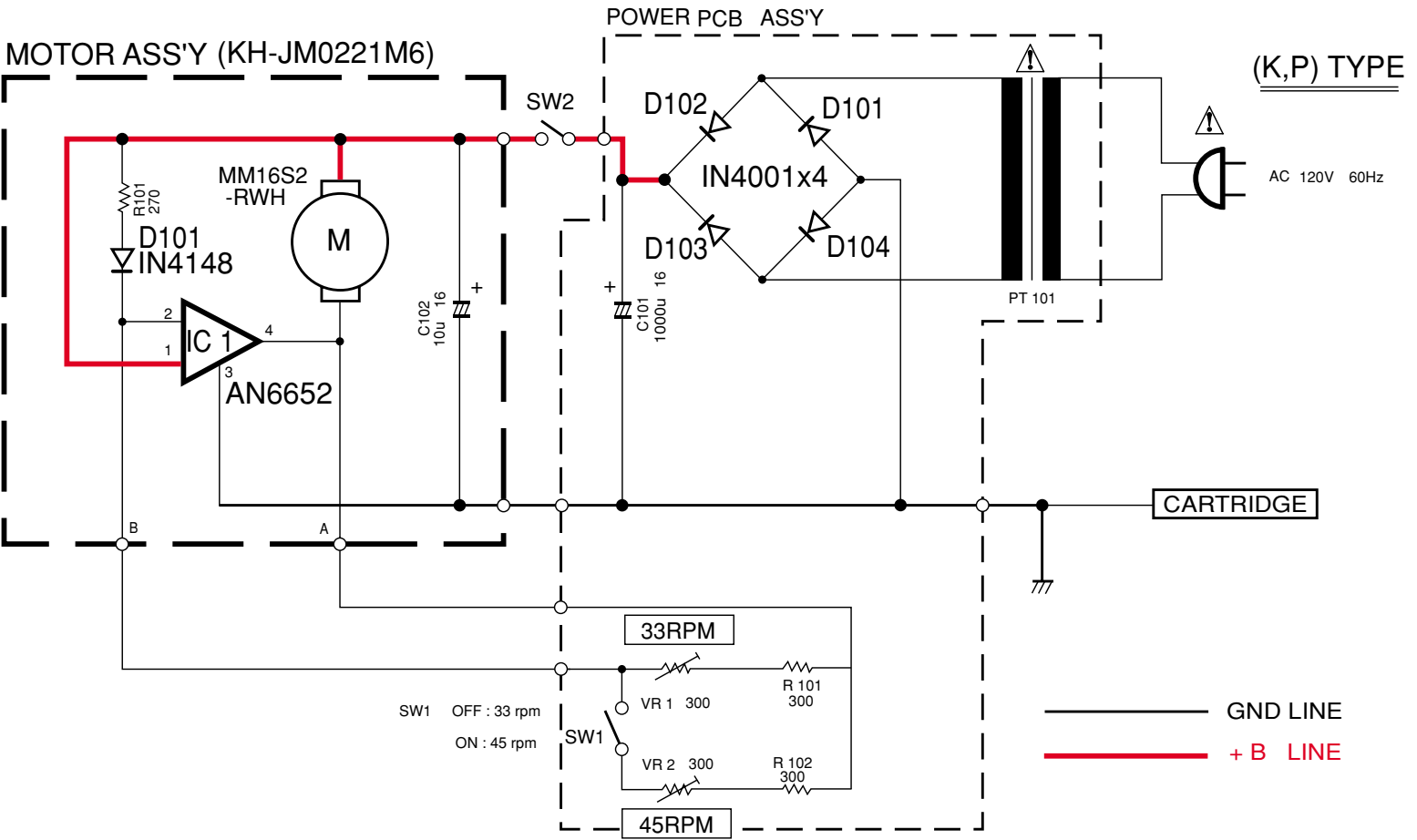

(K,P) TYPE

AC 120V 60Hz

CARTRIDGE

GND LINE

+ B LINE

M TYPE

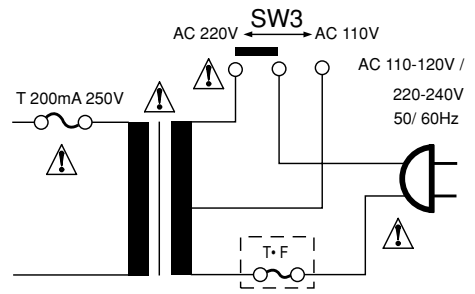

Y TYPE

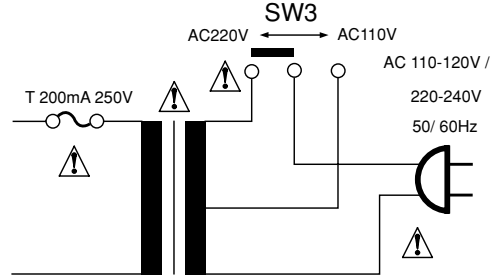

(X,T,E) TYPE

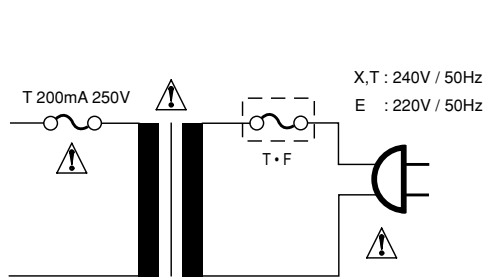

X,T : 240V / 50Hz
E : 220V / 50Hz

CAUTION: For continued safety, replace safety critical components only with manufacturer's recommended parts (refer to parts list). ⚠ indicates safety critical components. To reduce the risk of electric shock, leakage-current or resistance measurements shall be carried out (exposed parts are acceptably insulated from the supply circuit) before the appliance is returned to the customer.

DC voltages are as measured with a high impedance voltmeter at 33-1/3 r.p.m. mode. Values may vary slightly due to variations between individual instruments or/and units.

Y21-3250-10

KD-291R/291RC

KENWOOD

KD-291R/291RC

EXPLODED VIEW

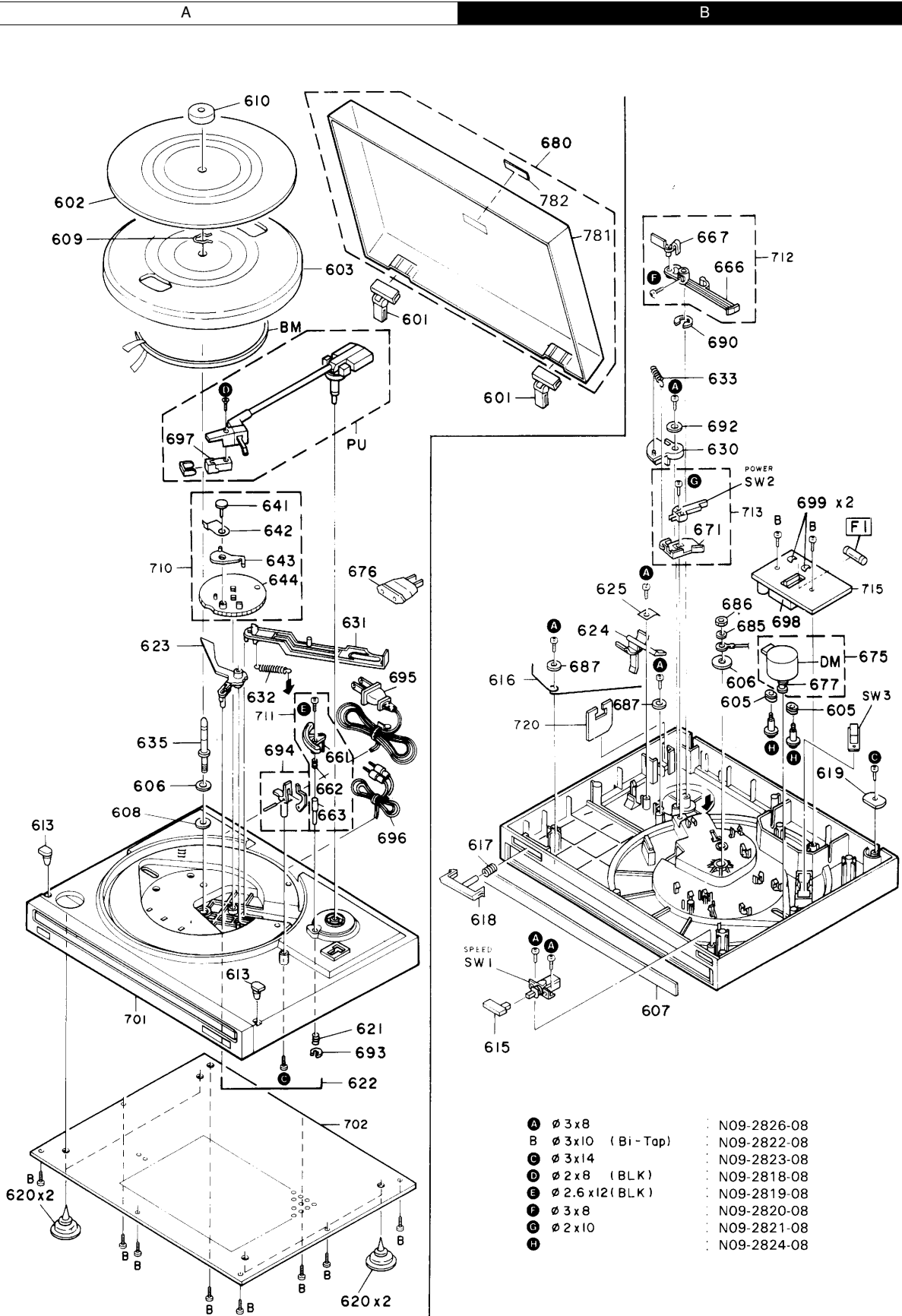

* New Parts
 Parts without **Parts No.** are not supplied.
 Les articles non mentionnés dans le **Parts No.** ne sont pas fournis.
 Teile ohne **Parts No.** werden nicht geliefert.

①

Ref. No	Add-ress	New Parts	Parts No.	Description	Desti-nation	Re-marks
KD-291R/KD291RC						
601	1A,1B	*	J50-0135-08	HINGE ASSY		
602	1A	*	G16-0775-08	RUBBER SHEET		
603	1A	*	D02-0104-08	PLATTER		
605	2B	*	G11-2058-08	CUSHION(MOTOR)		
606	2A,2B	*	N19-1257-08	WASHER PLAIN		
607	3B	*	B03-2730-08	PLATE FRONT		
608	2A	*	N19-1258-08	POLY WASHER		
609	1A	*	G09-0615-08	STOPPER PLATTER		
610	1A	*	W01-0329-04	ADAPTER EP		
613	2A,3A	*	G11-2059-08	CUSHION(DUST COVER)		
615	3B	*	K27-2028-08	KNOB(SPEED)		
616	2B	*	D10-3137-08	LINK CUT		
617	2B	*	G01-3357-08	SPRING BUTTON		
618	2B	*	K27-2026-08	KNOB/CUT		
619	2B	*	J19-3414-08	STOPPER CORD		
620	3A	*	J02-1063-08	FOOT RUBBER		
621	3A	*	G01-3358-08	SPRING(ELEVATION)		
622	3A	*	D10-3136-08	LINK		
623	2A	*	D10-3138-08	LEVER REJECT		
624	2B	*	K27-2027-08	HANDLE LIFTER		
625	2B	*	J21-5730-08	HOLDER LEVER		
630	1B	*	D12-0130-08	ELEVATION		
631	2A	*	D10-3139-08	ARM ACTUATION		
632	2A	*	G01-3359-08	SPRING(ACTUATING)		
633	1B	*	G01-3360-08	SPRING(ELEVATOR)		
635	2A	*	D21-1652-08	CENTER SHAFT		
641	2A	*	D32-0194-08	LOCK CLUTCH		
642	2A	*	D19-0263-08	PLATE CLUTCH		
643	2A	*	D19-0264-08	GUIDE CLUTCH		
644	2A	*	D13-0940-08	GEAR RING		
661	2A	*	J99-0501-08	ARM ELEVATION		
662	2A	*	G01-3361-08	SPRING(ADJUST)		
663	2A	*	D21-1653-08	SHAFT(ELEVATION)		
666	1B	*	D10-3140-08	ARM FEED		
667	1B	*	D21-1654-08	CAM ADJUST		
671	2B	*	J19-3415-08	HOLDER S/W		
675	2B	*	T42-0586-08	MOTOR PULLEY ASSY		
676	2A	*	E03-0115-08	AC PLUG ADAPTER	M	
677	2B	*	D15-0315-08	PULLEY MOTOR		
680	2B	*	A53-1301-08	DUST COVER ASSY		
685	2B	*	N16-0040-46	WASHER SPRING		
686	2B	*	N10-2040-46	NUT		
687	2B	*	N19-1259-08	WASHER PLAIN		
690	1B	*	N29-0269-08	E-RING		
692	1B	*	N19-1260-08	WASHER PLAIN		
693	3A	*	N29-0207-08	E-RING		
694	2A	*	J19-3416-08	ARM STAND ASSY		
695	2A	*	E30-2645-08	CORD AC	KPY	
695	2A	*	E30-2646-08	CORD AC	X	
695	2A	*	E30-2647-08	CORD AC	ME	
696	2A	*	E30-2649-08	CORD PHONO		
697	1A	*	T21-0157-08	CARTRIDGE(V-76)		
698	2B	*	L07-0320-08	POWER TRANSFORMER	KP	

L : Scandinavia K : USA P : Canada R : Mexico C : China I : Malaysia
 Y : PX(Far East,Hawaii) T : England E : Europe G : Germany V : China(Shanghai)
 Y : AAFES(Europe) X : Australia Q : Russia H : Korea M : Other Areas Δ indicates safety critical components .

* New Parts
 Parts without **Parts No.** are not supplied.
 Les articles non mentionnés dans le **Parts No.** ne sont pas fournis.
 Teile ohne **Parts No.** werden nicht geliefert.

②

Ref. No	Add-ress	New Parts	Parts No.	Description	Desti-nation	Re-marks
Δ 698	2B	*	L07-0321-08	POWER TRANSFORMER	M	
Δ 698	2B	*	L07-0322-08	POWER TRANSFORMER	Y	
Δ 698	2B	*	L07-0323-08	POWER TRANSFORMER	X	
Δ 698	2B	*	L07-0324-08	POWER TRANSFORMER	E	
699	2B	*	J13-0078-08	FUSE CLIP		
-			B46-0092-03	WARRANTY CARD	K	
-			B46-0094-03	WARRANTY CARD	Y	
-			B46-0095-03	WARRANTY CARD	Y	
-			B46-0096-13	WARRANTY CARD	X	
-			B46-0121-03	WARRANTY CARD	P	
-			B46-0122-13	WARRANTY CARD	E	
-		*	B58-0513-08	CAUTION CARD	Y	
-		*	B59-0167-08	SUB-INSTRUCTION MANUAL(E/F/D)	KPYXE	
-		*	B59-0168-08	SUB-INSTRUCTION MANUAL(E/S/C)	M	
-		*	B60-0449-08	INSTRUCTION MANUAL(ENGLISH)	KYX	
-		*	B60-0450-08	INSTRUCTION MANUAL(FRENCH)	P	
-		*	B60-0451-08	INSTRUCTION MANUAL(GERMANY)	E	
-		*	B60-0452-08	INSTRUCTION MANUAL(E/S/C)	M	
-		*	H10-3840-08	POLYSTYRENE FOAMED FIXTURE		
-		*	H25-0232-04	P.E.BAG/MANUAL		
-		*	H25-0641-08	P.E.BAG/SET		
-		*	H25-0642-08	P.E.BAG		
-		*	H50-0061-08	ITEM CARTON BOX(KD-291RC)	K	
-		*	H50-0062-08	ITEM CARTON BOX(KD-291R)	PMYXE	
A		*	N09-2826-08	SCREW		
B		*	N09-2822-08	SCREW		
C		*	N09-2823-08	SCREW		
D		*	N09-2818-08	SCREW		
E		*	N09-2819-08	SCREW		
F		*	N09-2820-08	SCREW		
G		*	N09-2821-08	SCREW		
H		*	N09-2824-08	SCREW MOTOR SETTING		
BM	1A	*	D16-0317-08	BELT RUBBER		
PU	1A	*	J91-0399-08	TONARM ASSY		
SW1	3B	*	S70-0001-08	S/W(SPEED)		
SW2	2B	*	S74-0002-08	S/W LEAF(POWER)		
Δ SW3	2B	*	S62-0004-08	V/SELECTOR S/W (AC220V/110V)	MY	
DM	2B	*	T42-0587-08	MOTOR		
POWER SUPPLY/CONTROL						
C101			CE04KW1C102J	ELECTRO 1000UF 16WV		
Δ F1	2B	*	F50-0008-08	FUSE (T200MA/250V)	YMX	
VR1 ,2		*	R12-0119-08	TRIMMING POT. 300-OHM,SPEED		
D101-104			1N4001	DIODE		

L : Scandinavia K : USA P : Canada R : Mexico C : China I : Malaysia
 Y : PX(Far East,Hawaii) T : England E : Europe G : Germany V : China(Shanghai)
 Y : AAFES(Europe) X : Australia Q : Russia H : Korea M : Other Areas Δ indicates safety critical components .

KD-291R/291RC

PARTS DESCRIPTIONS

CAPACITORS

CC 45 TH 1H 220 J
 1 2 3 4 5 6

- 1 = Type ... ceramic, electrolytic, etc.
- 2 = Shape ... round, square, ect.
- 3 = Temp. coefficient
- 4 = Voltage rating
- 5 = Value
- 6 = Tolerance

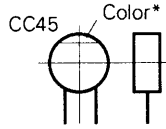

Capacitor value

- 010 = 1pF
- 100 = 10pF
- 101 = 100pF
- 102 = 1000pF = 0.001μF
- 103 = 0.01μF

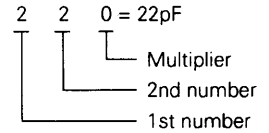

Temperature coefficient

1st Word	C	L	P	R	S	T	U
Color*	Black	Red	Orange	Yellow	Green	Blue	Violet
ppm/°C	0	-80	-150	-220	-330	-470	-750

2nd Word	G	H	J	K	L
ppm/°C	±30	±60	±120	±250	±500

Example : CC45TH = -470 ± 60ppm/°C

Tolerance (More than 10pF)

Code	C	D	G	J	K	M	X	Z	P	No code
(%)	±0.25	±0.5	±2	±5	±10	±20	+40 -20	+80 -20	+100 -0	More than 10μF -10 ~ +50 Less than 4.7μF -10 ~ +75

(Less than 10pF)

Code	B	C	D	F	G
(pF)	±0.1	±0.25	±0.5	±1	±2

Voltage rating

1st word \ 2nd word	A	B	C	D	E	F	G	H	J	K	V
	0	1.0	1.25	1.6	2.0	2.5	3.15	4.0	5.0	6.3	8.0
1	10	12.5	16	20	25	31.5	40	50	63	80	35
2	100	125	160	200	250	315	400	500	630	800	-
3	1000	1250	1600	2000	2500	3150	4000	5000	6300	8000	-

Chip capacitors

(EX) C C 7 3 F S L 1 H 0 0 0 J
 1 2 3 4 5 6 7

(Chip) (CH, RH, UJ, SL)

(EX) C K 7 3 F F 1 H 0 0 0 Z
 1 2 3 4 5 6 7

(Chip) (B, F)

Refer to the table above.

- 1 = Type
- 2 = Shape
- 3 = Dimension
- 4 = Temp. coefficient
- 5 = Voltage rating
- 6 = Value
- 7 = Tolerance

Dimension (Chip capacitors)

Dimension code	L	W	T
Empty	5.6 ± 0.5	5.0 ± 0.5	Less than 2.0
A	4.5 ± 0.5	3.2 ± 0.4	Less than 2.0
B	4.5 ± 0.5	2.0 ± 0.3	Less than 2.0
C	4.5 ± 0.5	1.25 ± 0.2	Less than 1.25
D	3.2 ± 0.4	2.5 ± 0.3	Less than 1.5
E	3.2 ± 0.2	1.6 ± 0.2	Less than 1.25
F	2.0 ± 0.3	1.25 ± 0.2	Less than 1.25
G	1.6 ± 0.2	0.8 ± 0.2	Less than 1.0

RESISTORS

Chip resistor (Carbon)

(EX) R K 7 3 E B 2 B 0 0 0 J
 1 2 3 4 5 6 7

(Chip) (B, F)

Carbon resistor (Normal type)

(EX) R D 1 4 B B 2 C 0 0 0 J
 1 2 3 4 5 6 7

- 1 = Type
- 2 = Shape
- 3 = Dimension
- 4 = Temp. coefficient
- 5 = Rating wattage
- 6 = Value
- 7 = Tolerance

Dimension

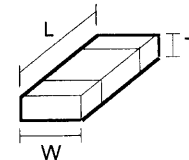

Dimension (Chip resistor)

Dimension code	L	W	T
E	3.2 ± 0.2	1.6 ± 0.2	1.0
F	2.0 ± 0.3	1.25 ± 0.2	1.0
G	1.6 ± 0.2	0.8 ± 0.2	0.5 ± 0.1

Rating wattage

Code	Wattage	Code	Wattage	Code	Wattage
1J	1/16W	2C	1/6W	3A	1W
2A	1/10W	2E	1/4W	3D	2W
2B	1/8W	2H	1/2W		

KD-291R/291RC

SPECIFICATIONS

Motor and turntable

Drive system..... Belt-Drive System
Motor DC Servo Motor
Speeds 2 Speeds, 33-1/3 and 45 rpm.

Tonearm

Type..... Integrated Straight Tonearm

Cartridge

Type..... VM type (V-76)
Stylus N-76 with 0.6 mil Diamond
Frequency Response... 20 Hz to 20,000 Hz
Output Voltage 2.5 mV(1,000 Hz, 5.0 cm/sec)
Load Impedance..... 47 k Ω
Compliance..... 4x10⁻⁶ cm/dyne

Miscellaneous

Power Consumption 4W
Dimensions..... W: 440 mm (17-5/16")
H: With Dust Cover: 106 mm
(4-3/16")
With out Dust Cover: 92mm
(3-5/8")
D: With Dust Cover: 390 mm
(15-3/8")
With out Dust Cover: 348 mm
(13-11/16")

Weight (Net)..... 2.9 Kg (6.4 lb)

KENWOOD follows a policy of continuous advancements in development. For this reason specifications may be changed without notice.

KENWOOD poursuit une politique de progrès constants en ce qui concerne le développement. Pour cette raison, les spécifications sont sujettes à modifications sans préavis.

KENWOOD strebt ständige, Verbesserungen in der Entwicklung an. Daher bleiben Änderungen der technischen Daten jederzeit vorbehalten.

Note:

Component and circuit are subject to modification to insure best operation under differing local conditions. This manual is based on Europe (E) standard, and provides information on regional circuit modification through use of alternate schematic diagrams, and information on regional component variations through use of parts list.

KENWOOD CORPORATION

14-6,Dogenzaka 1-chome, Shibuya-ku, Tokyo, 150-8501 Japan

KENWOOD SERVICE CORPORATION

P.O BOX 22745, 2201 East Dominguez St., Long Beach, CA 90801-5745, U.S.A.

KENWOOD ELECTRONICS CANADA INC.

6070 Kestrel Road, Mississauga, Ontario, Canada L5T 1S8

KENWOOD ELECTRONICS LATIN AMERICA S.A.

P.O BOX 55-2791, Piso 6 plaza Chase, Cl. 47 y Aquilino de la Guardia Panama, Republic de Panama

KENWOOD ELECTRONICS BRASIL LTDA.

Av. Moema, 170-17, Andar-Cobertura "B", Ed. Maximum Service Center, 04077-020 Moema, São Paulo-SP-Brasil

KENWOOD ELECTRONICS U.K. LIMITED

KENWOOD House, Dwight Road, Watford, Herts., WD1 8EB., United Kingdom

KENWOOD ELECTRONICS BELGUM N.V.

Meachelsesteenweg 418, B-1930 Zaventem, Belgium

KENWOOD ELECTRONICS DEUTSCHLAND GMBH

Rembrücker Str. 15, 63150 Heusenstamm, Germany

KENWOOD ELECTRONICS FRANCE S.A.

13 Boulevard Ney, 75018 Paris, France

KENWOOD ELECTRONICS ITALIA S.p.A.

Via G. Sirtori, 7/9 20129, Milano, Italy

KENWOOD IBÉRICA S.A.

Bolivia, 239-08020 Barcelona, Spain

KENWOOD ELECTRONICS AUSTRALIA PTY. LTD.

(A.C.N. 001 499 074)
16 Giffnock Avenue, North Ryde, N.S.W. 2113, Australia

KENWOOD ELECTRONICS (HONG KONG) LTD.

Unit 3712-3724, Level 37, Tower 1, Metroplaza, 223 Hing Fong Road, Kwai Fong N.T., Hong Kong

KENWOOD ELECTRONICS GULF FZE

P.O.Box 61318, Jebel Ali, Dubai, U.A.E.

KENWOOD ELECTRONICS SINGAPORE PTE LTD.

No. 1 Genting Lane #02-02, KENWOOD Building, Singapore, 349544

KENWOOD ELECTRONICS (MALAYSIA) SDN BHD.

#4.01 Level 4, Wisma Academy Lot 4A, Jalan 19/1 46300 Petaling Jaya Selangor Darul Ehsan Malaysia

KENWOOD ELECTRONICS (THAILAND) CO., LTD.

2019 New Pechburi Road, Bangkapi, Huaykwang, Bangkok, 10320 Thailand