

BASKET GROUP

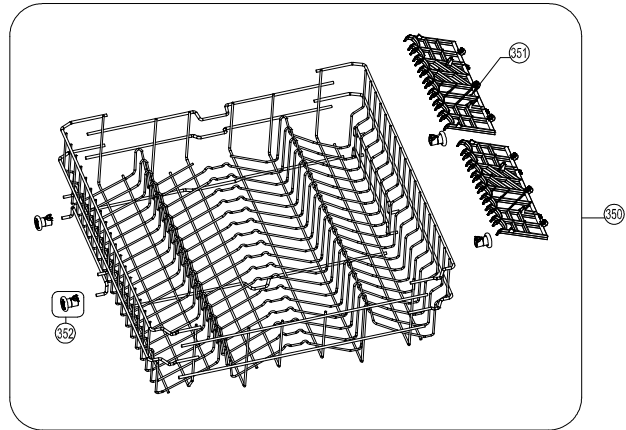

NO	PART NAME	QUANTITY
300	LOWER BASKET GROUP - FIXED COMB - (301)	1
301	LOWER BASKET WHEEL GROUP	8
350	UPPER BASKET GROUP - (351 – 352)	1
351	MUG SHELVE	2
352	UPPER BASKET WHEEL GROUP	4
325	PLASTIC SET BASKET (326-327-328)	1
326	PLASTIC BASKET HANDLE	1
327	PLASTIC BASKET COVER	2
328	PLASTIC BASKET	1

CONTROL PANEL GROUP

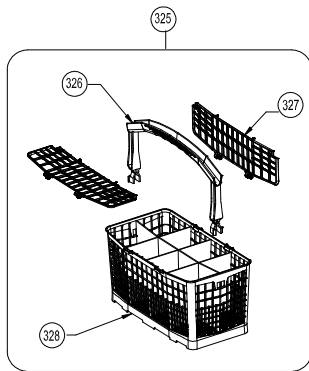
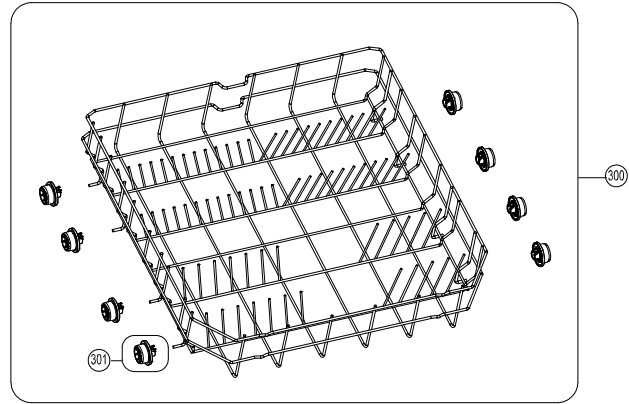
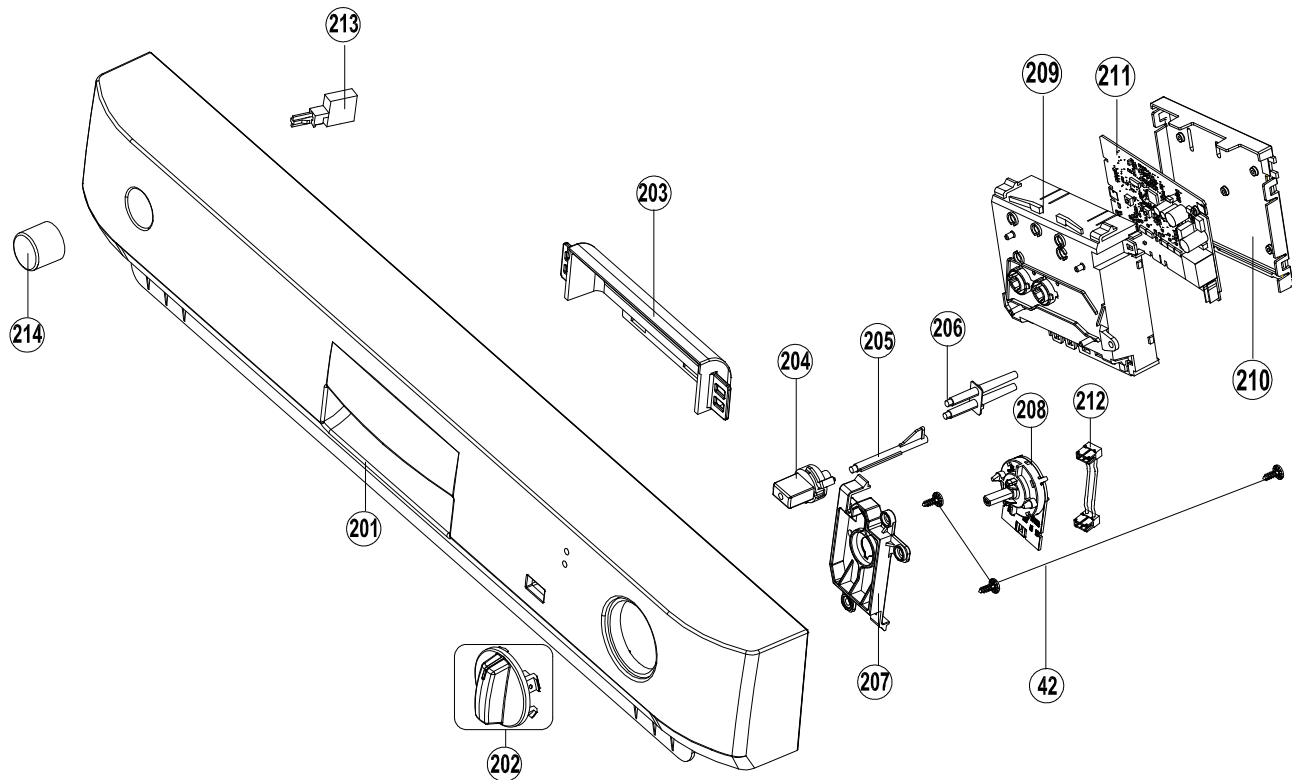

NO	PART NAME	QUANTITY
200	CON.PAN.GROUP (201-202-203-204-205-206-207-208-209-210- 42)	1
201	CON.PAN.PRINTED	1
202	KNOB GR	1
203	HANDLE	1
204	ELECTRONIC BUTTON-1	1
205	ELECTRONIC BUTTON SHAFT-1	1
206	LIGHT GUIDE-2	1
207	ROTARY SWITCH CONNECTION PLS.	1
208	ROTARY SWITCH	1
209	PCB BOX-1 BODY	1
210	PCB BOX-1 REAR COVER	1
211	ELECT.CARD	1
212	ROTARY SWITCH CABLE	1
213	ON/OFF SWITCH	1
214	ON/OFF BUTTON	1
42	SCREW PT3,5X9 YSB	3

WATER SOFTENER GROUP

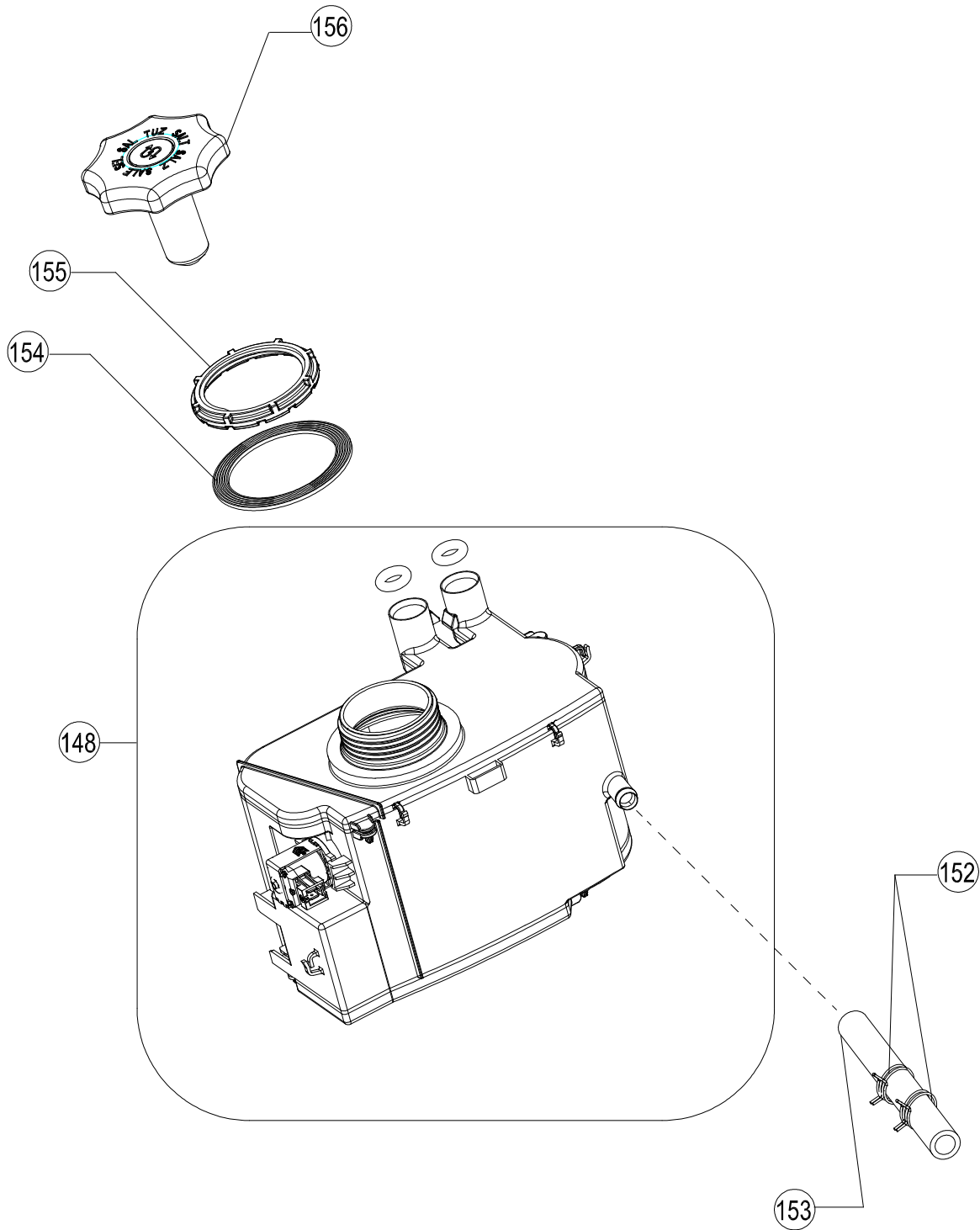

NO	PART NAME	QUANTITY
148	WATER SOFTENER GR.WITHOUT REED RELAY (151)	1
152	CLAMP Dmax19,6X8,8	2
153	HOSE D12*3*160	1
154	WATER SOFTENER NUT GASKET	1
155	WATER SOFTENER NUT	1
156	SALT CAP GROUP (OPTICAL VERSION)	1

UPPER HYDRAULIC GROUP

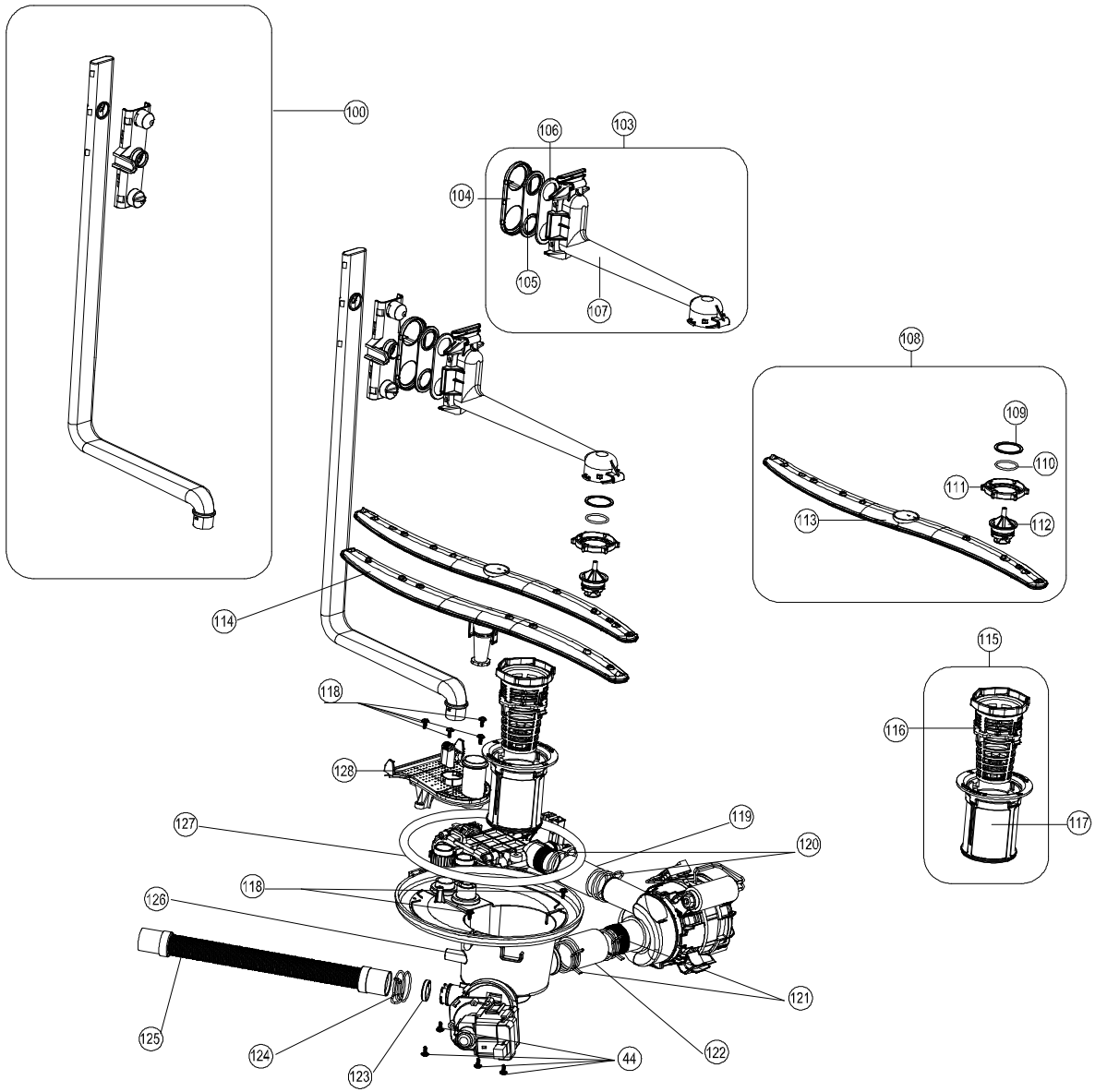

NO	PART NAME	QUANTITY
100	UPPER SPRAY ARM FEEDING CANAL-L	1
103	UPPER SPRAY ARM SUPPORT GROUP (104-105-106-107)	1
104	UPPER SPRAY ARM ADAPTER COVER	1
105	UPPER SPRAY ARM ADAPTER GASKET	1
106	UPPER SPRAY ARM ADAPTER FLANGE	1
107	UPPER SPRAY ARM SUPPORT	1
108	UPPER SPRAY ARM GROUP(113-112-111-110-109)	1
109	UPPER SPRAY ARM NUT PLASTIC	1
110	UPPER SPRAY ARM SHAFT O-RING	1
111	UPPER SPRAY ARM NUT	1
112	UPPER SPRAY ARM SHAFT	1
113	UPPER SPRAY ARM	1

NO	PART NAME	QUANTITY
114	LOWER SPRAY ARM	1
115	MICROFILTER GROUP (116-117)	1
116	COURSE FILTER	1
117	MICROFILTER	1
118	SCREW PT4X12 YSB INOX	6
119	HOSE D28,5X3	1
120	CLAMP Dmax36,4X14	2
121	CLAMP Dmax41X14,8	2
122	HOSE D33X3	1
123	KLAPE	1
124	CLAMP Dmax29,4X11,4)	1
125	DRAIN HOSE 200 CM	1
126	SUMP	1
127	SUMP SEAL	1
128	SPRAY ARM SUPPORT	1
44	SCREWPT4X12YSB	4

LOWER HYDROLIC GROUP

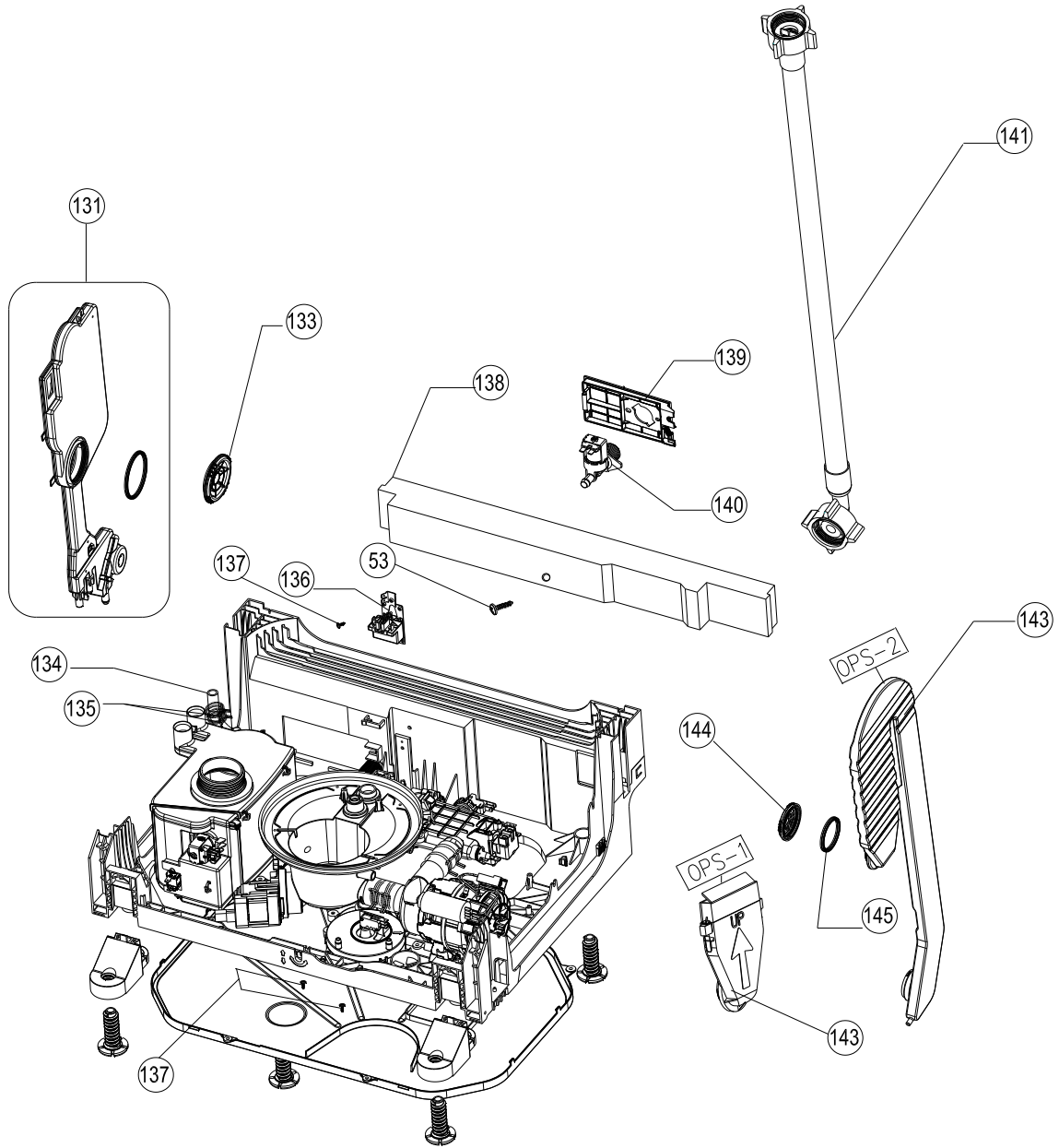

NO	PART NAME	QUANTITY
131	AIR BREAK GROUP	1
133	AIR BREAK NUT	1
134	HOSE D10*3*230 PVC/WITH CORD	1
135	CLAMP Dmax16,8x8,4	2
136	PARASITE FILTER	1
137	SCREW PT3X9 YSB	3
138	CONCRETE WEIGHT	1
139	BASEMENT HOSE.CON.PLS.	1
140	WATER INLET VALVE	1
141	WATER INLET HOSE GROUP	1
143	STEAM CONDENSER (PLEASE ORDER THE SPARE PART WHICH IS USED IN YOUR MACHINE)	1
144	STEAM CONDENSER NUT	1
145	STEAM CONDENSER SEALING GASKET	1
53	SCREW 4X42,5 YHB	1

DOOR GROUP

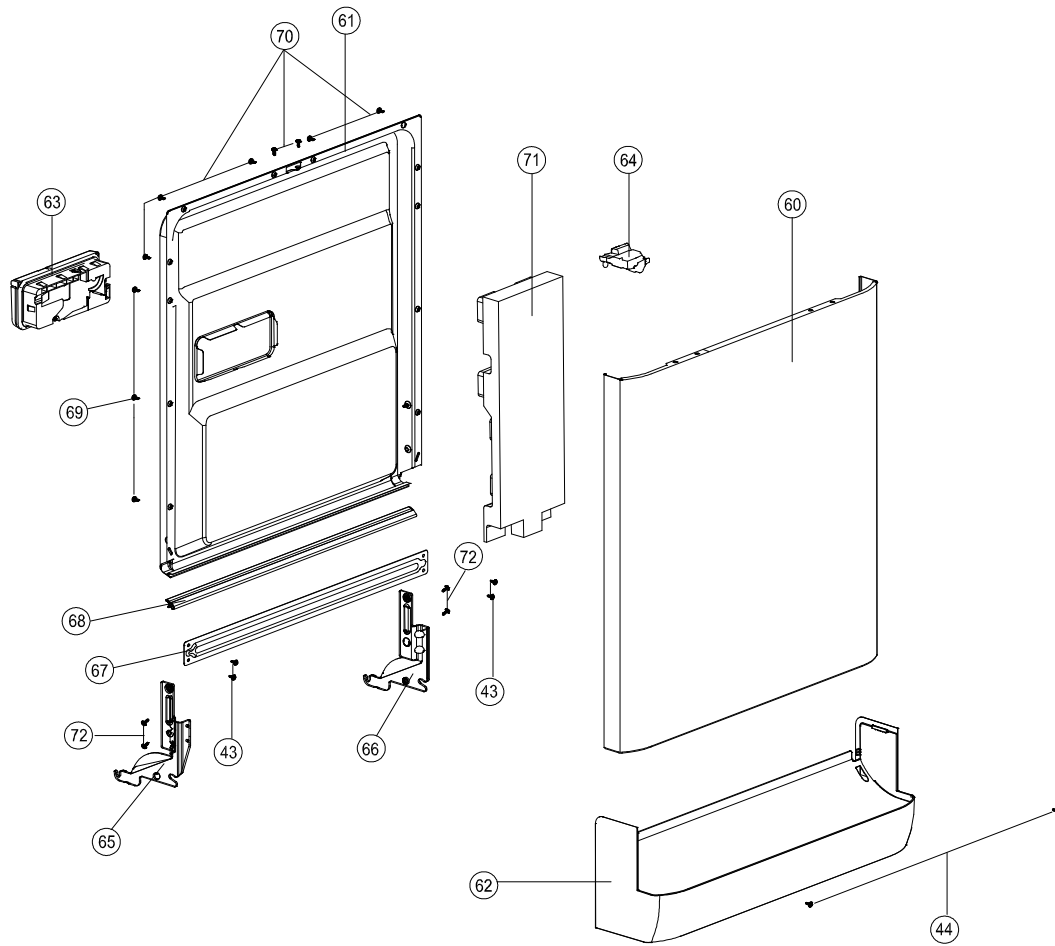

NO	PART NAME	QUANTITY
60	DOOR OUTSIDE	1
61	DOOR INSIDE SHEETIRON GROUP	1
62	PLASTIC KICK PLATE	1
63	DISPANSER WITHOUT REED RELAY	1
64	DOOR LOCK	1
65	HINGE MOVEMENT SHEETIRON LEFT	1
66	HINGE MOVEMENT SHEETIRON RIGHT	1
67	TWISTED SHEETIRON	1
68	DOOR SEAL	1
69	SCREW ST 3.9X12 FLAT HEAD INOX	6
70	SCREW PT4X14 FLAT HEAD INOX	8
71	DOOR SUPPORT STYROFOAM	1
72	SCREW M5X10 TORK HEAD (S)	4
43	SCREW M4X9 PAN HEAD (S)	4
44	SCREW PT 4X12 PAN HEAD COLLAR CROSS	2

TUBE GROUP

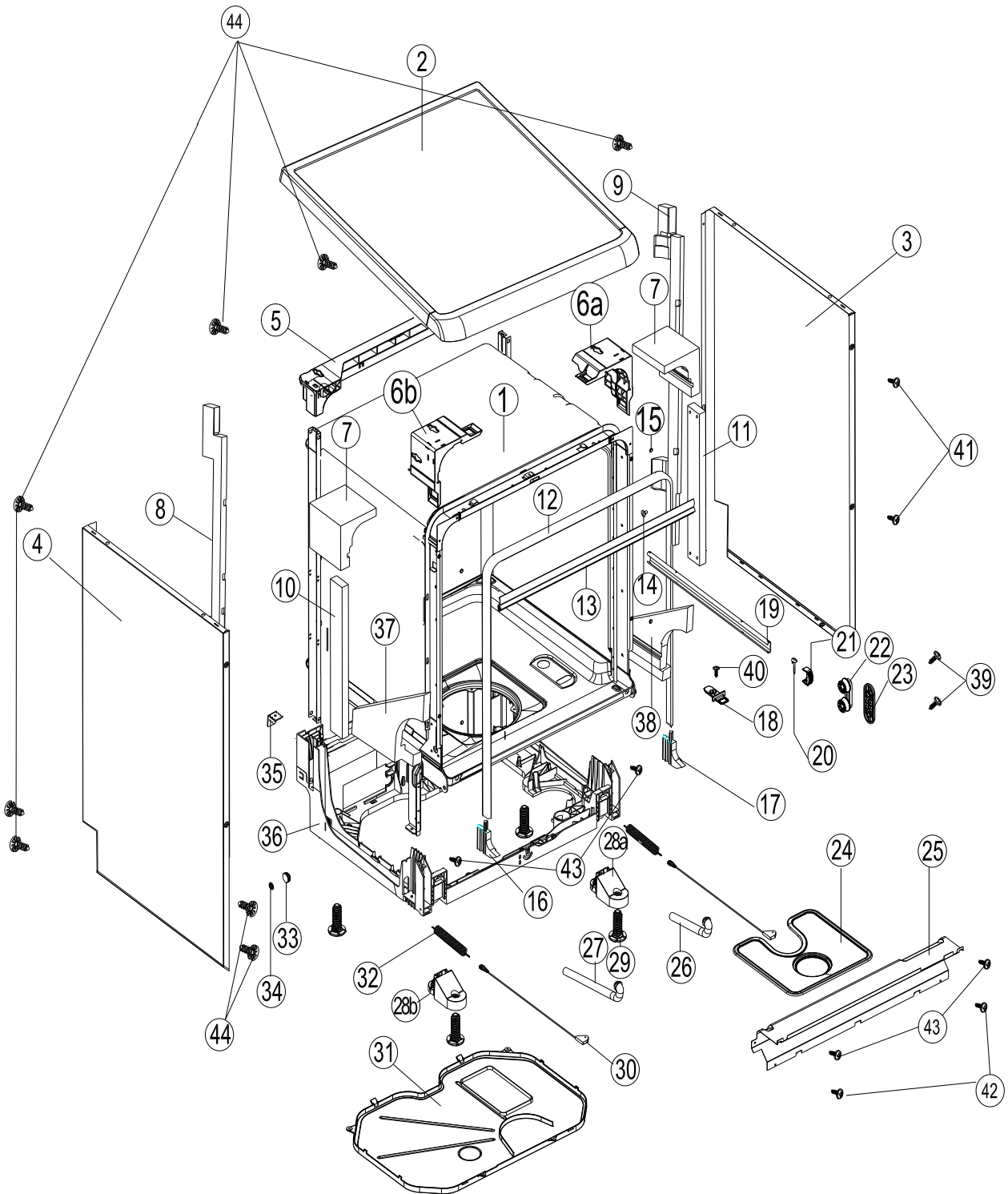

NO	PART NAME	QUANTITY
1	TUBE ASSEMBLY	1
2	UPPER TRAY GROUP	1
3	FLAT/SIDE PANEL SHEETIRON-RIGHT	1
4	FLAT/SIDE PANEL SHEETIRON-LEFT	1

NOT: The spare part with poz no 14 is not valid form 06.2011

5	REAR UPPER PLS.CROSS BAR	1
6a	UPPER TRAY SUPPORT PART/RIGHT	1
6b	UPPER TRAY SUPPORT PART - LEFT	1
7	TUB TOP CORNER STYROFOAM	2
8	BACK CROSS BAR STYROFOAM-LEFT	1
9	BACK CROSS BAR STYROFOAM-RIGHT	1
10	FRONT CROSS BAR STYROFOAM-LEFT	1
11	FRONT CROSS BAR STYROFOAM-RIGHT	1
12	TUB GASKET	1
13	TOP TUB OF GASKET	2
14	TUB HOLE PLUG	2
15	SIDE PANEL FRONT CROSS BAR SCR CUPS/	4
16	BOTTOM CORNER GASKET-LEFT	1
17	BOTTOM CORNER GASKET-RIGHT	1
18	LATCH DOOR	1
19	UPPER BASKET RAIL	2
20	UPPER BASKET STOPPER-REAR	2
21	UPPER BASKET RAIL LOCK-FRONT	2
22	UPPER BASKET RAIL CON.BRA.GROUP	4
23	UPPER BASKET RAIL CON.BRA -REAR	4
24	METAL/PLASTIC FILTER	1
25	KICKPLATE SHEETIRON	1
26	OVERFLOW PIECE FROM TUB WITH HOSE/300mm	1
27	OVERFLOW PIECE FROM TUB WITH HOSE/450 mm	1
28a	FRONT FOOT CONN.PART-2 / RIGHT	1
28b	FRONT FOOT CONN.PART-2 / LEFT	1
29	ADJUSTED FOOT	4
30	HINGE CORD GROUP	2
31	LOWER COVER	1
32	HINGE SPRING	2
33	HINGE PULLEY	4
34	FIXED PULLEY SEG	4
35	SPRING CONNECTION PART	2
36	BASEMENT	1
37	TUB LOWER CORNER STYROFOAM-LEFT	1
38	TUB LOWER CORNER STYROFOAM-RIGHT	1
39	SCREW PT5X20 WN 5451 TORX RONDELALI	8
40	SCREW M4X6 SB	1
41	SCREW 3,9X9,5 FLAT HEAD	4
42	SCREW PT3,5X9 PAN HEAD COLLAR CROSS)	2
43	SCREW M4*9 SB PAN HEAD (S)	4
44	SCREW PT4X12 PAN HEAD COLLAR CROSS	12

COMPONENTS

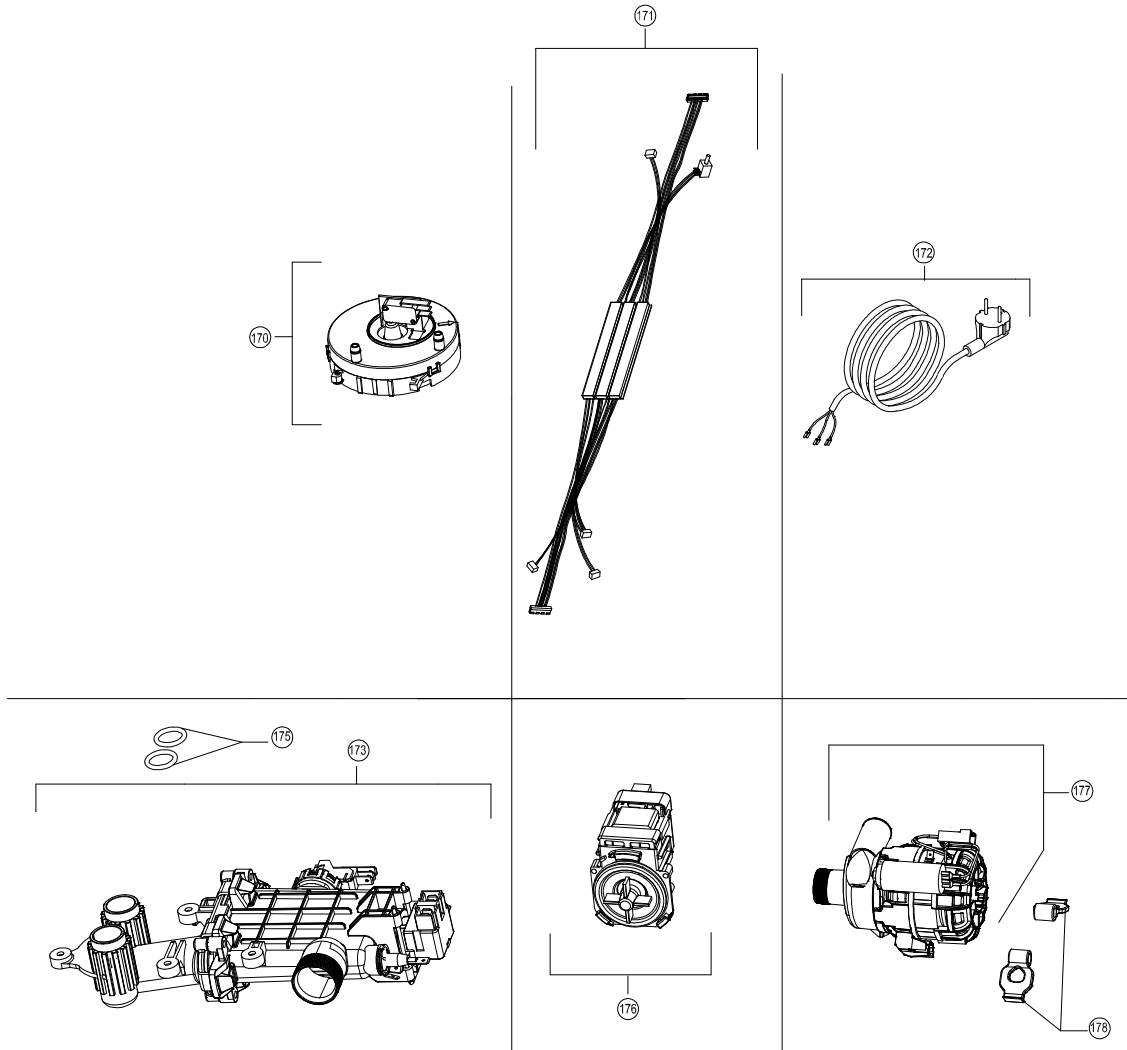

NO	PART NAME	QUANTITY
170	FLOATER	1
171	CABLE HARNESS	1
172	POWER CABLE 180cm/WHITE	1
173	HEATER CASING WITHOUT DIVERTER	1
175	HEATER CASING O-RING	2
176	DRAIN PUMP	1
177	WASHING PUMP	1
178	WASHING PUMP VINE SUPPORT	2