

# Service Manual

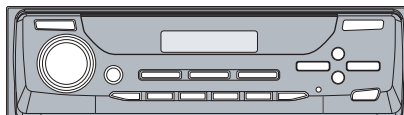

ORDER NO.  
**CRT2846**

MULTI-CD/DAB CONTROL HIGH POWER CD/MP3/WMA PLAYER WITH RDS TUNER

# DEH-P8400MP

XN/EW



● This service manual should be used together with the following manual(s):

Model No.	Order No.	Mech. Module	Remarks
CX-3007	CRT2820	S9MP3	CD Mech. Module:Circuit Description, Mech.Description, Disassembly

## CONTENTS

1. SAFETY INFORMATION .....	3	7. GENERAL INFORMATION .....	59
2. EXPLODED VIEWS AND PARTS LIST .....	4	7.1 DIAGNOSIS .....	59
3. BLOCK DIAGRAM AND SCHEMATIC DIAGRAM ...	12	7.1.1 DISASSEMBLY .....	59
4. PCB CONNECTION DIAGRAM .....	32	7.1.2 CONNECTOR FUNCTION DESCRIPTION .....	68
5. ELECTRICAL PARTS LIST .....	42	7.2 PARTS .....	69
6. ADJUSTMENT.....	49	7.2.1 IC.....	69
		7.2.2 DISPLAY .....	84
		7.3 OPERATIONAL FLOW CHART .....	85
		7.4 CLEANING .....	85
		8. OPERATIONS AND SPECIFICATIONS.....	86



For details, refer to "Important symbols for good services".

**PIONEER CORPORATION** 4-1, Meguro 1-Chome, Meguro-ku, Tokyo 153-8654, Japan  
**PIONEER ELECTRONICS (USA) INC.** P.O.Box 1760, Long Beach, CA 90801-1760 U.S.A.  
**PIONEER EUROPE NV** Haven 1087 Keetberglaan 1, 9120 Melsele, Belgium  
**PIONEER ELECTRONICS ASIACENTRE PTE.LTD.** 253 Alexandra Road, #04-01, Singapore 159936

## [ Important symbols for good services ]

In this manual, the symbols shown-below indicate that adjustments, settings or cleaning should be made securely. When you find the procedures bearing any of the symbols, be sure to fulfill them:

### 1. Product safety



You should conform to the regulations governing the product (safety, radio and noise, and other regulations), and should keep the safety during servicing by following the safety instructions described in this manual.

### 2. Adjustments



To keep the original performances of the product, optimum adjustments or specification confirmation is indispensable. In accordance with the procedures or instructions described in this manual, adjustments should be performed.

### 3. Cleaning



For optical pickups, tape-deck heads, lenses and mirrors used in projection monitors, and other parts requiring cleaning, proper cleaning should be performed to restore their performances.

### 4. Shipping mode and shipping screws



To protect the product from damages or failures that may be caused during transit, the shipping mode should be set or the shipping screws should be installed before shipping out in accordance with this manual, if necessary.

### 5. Lubricants, glues, and replacement parts



Appropriately applying grease or glue can maintain the product performances. But improper lubrication or applying glue may lead to failures or troubles in the product. By following the instructions in this manual, be sure to apply the prescribed grease or glue to proper portions by the appropriate amount. For replacement parts or tools, the prescribed ones should be used.

## ● CD Player Service Precautions



1. For pickup unit(CXX1550) handling, please refer to "Disassembly"(see page 59)

During replacement, handling precautions shall be taken to prevent an electrostatic discharge(Protection by a jumper-solder).

2. During disassembly, be sure to turn the power off since an internal IC might be destroyed when a connector is plugged or unplugged.

3. Please check the grating after changing the service pickup unit(see page 53).

## 1. SAFETY INFORMATION

This service manual is intended for qualified service technicians; it is not meant for the casual do-it-yourselfer. Qualified technicians have the necessary test equipment and tools, and have been trained to properly and safely repair complex products such as those covered by this manual.

Improperly performed repairs can adversely affect the safety and reliability of the product and may void the warranty. If you are not qualified to perform the repair of this product properly and safely, you should not risk trying to do so and refer the repair to a qualified service technician.

### 1. Safety Precautions for those who Service this Unit.

- When checking or adjusting the emitting power of the laser diode exercise caution in order to get safe, reliable results.

#### Caution:

1. During repair or tests, minimum distance of 13cm from the focus lens must be kept.
  2. During repair or tests, do not view laser beam for 10 seconds or longer.
2. A "CLASS 1 LASER PRODUCT" label is affixed to the bottom of the player.
  3. The triangular label is attached to the mechanism unit frame.

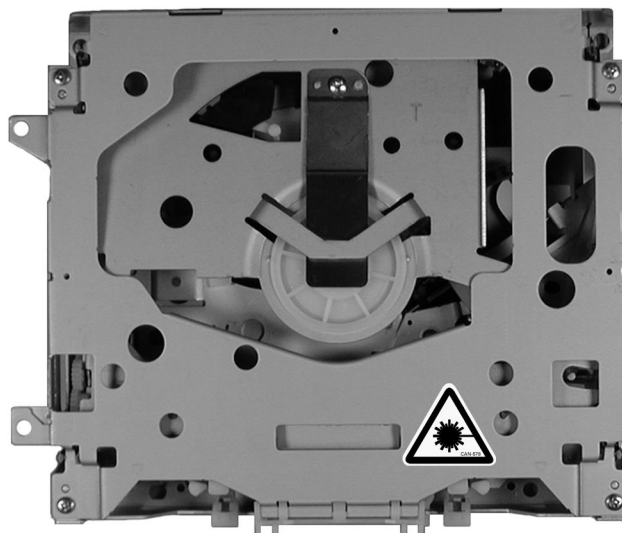

### 4. Specifications of Laser Diode

Specifications of laser radiation fields to which human access is possible during service.

Wavelength = 800 nanometers

#### CAUTION

Danger of explosion if battery is incorrectly replaced.  
 Replaced only with the same or equivalent type recommended by the manufacture.  
 Discard used batteries according to the manufacture's instructions.

## 2. EXPLODED VIEWS AND PARTS LIST

### 2.1 PACKING

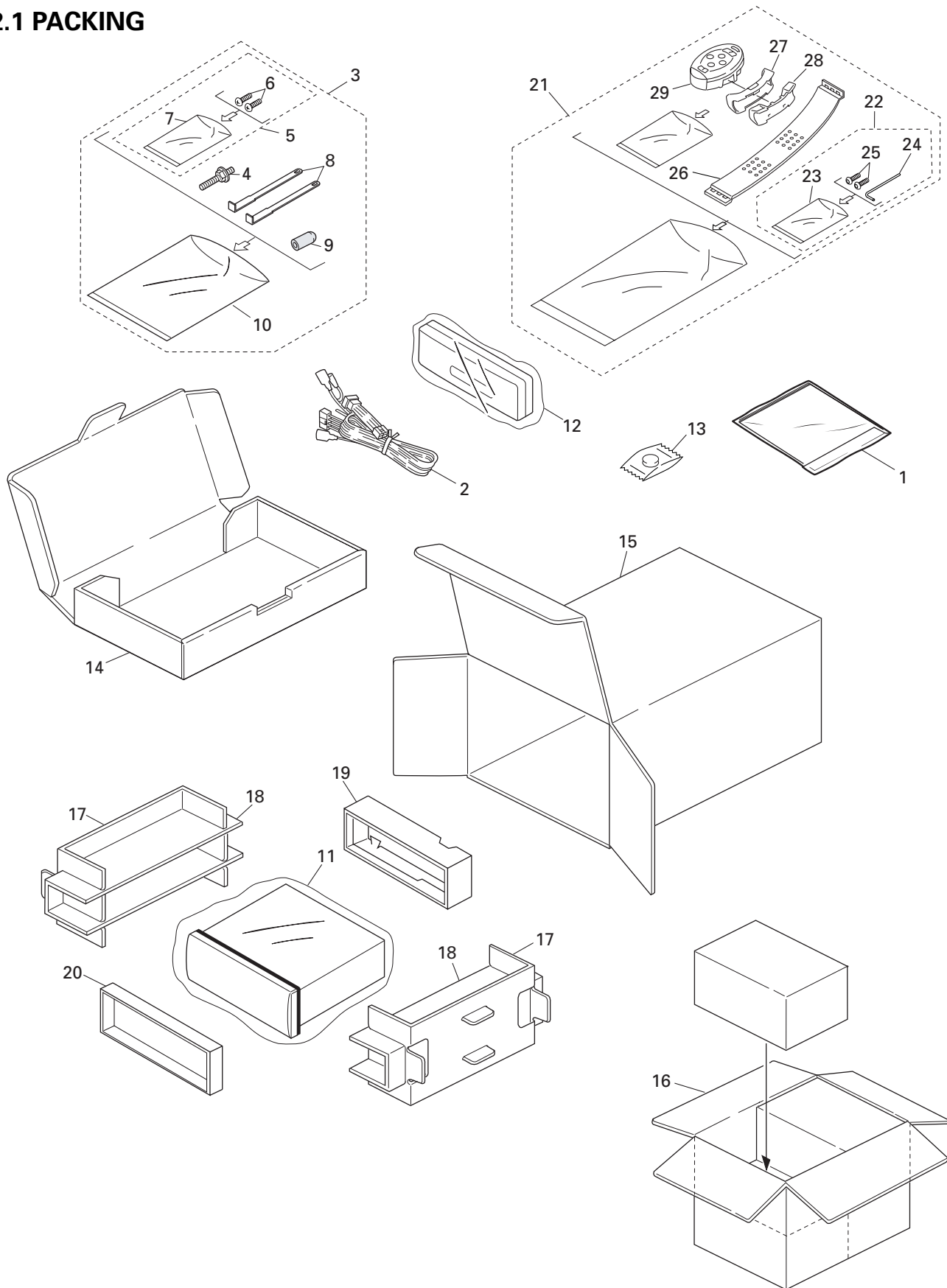

**NOTE:**

- Parts marked by "\*" are generally unavailable because they are not in our Master Spare Parts List.
- Screws adjacent to ∇ mark on the product are used for disassembly.
- For the applying amount of lubricants or glue, follow the instructions in this manual.  
( In the case of no amount instructions, apply as you think it appropriate.)

**● PACKING SECTION PARTS LIST**

Mark	No.	Description	Part No.	Mark	No.	Description	Part No.
	1-1	Owner's Manual	CRD3565		14	Sub Carton	CHA3258
	1-2	Owner's Manual	CRD3566		15	Carton	CHG4660
	1-3	Owner's Manual	CRD3567		16	Contain Box	CHL4660
	1-4	Installation Manual	CRD3568		17	Protector	CHP2538
*	1-5	Caution Card	CRP1268		18	Protector	CHP2539
*	1-6	Passport	CRY1013		19	Protector	CHP2541
*	1-7	Warranty Card	CRY1157		20	Protector	CHP2546
	1-8	Polyethylene Bag	CEG1116		21	Remote Control Assy	CXB9202
	2	Cord Assy	CDE6562		22	Screw Assy	CZE3169
	3	Accessory Assy	CEA3141	*	23	Polyethylene Bag	CEG-127
	4	Screw	CBA1002	*	24	Hexagonal Wrench	CZE3176
	5	Screw Assy	CEA3140	*	25	Screw	RMZ30H060FBK
	6	Screw	BPZ20P060FMC		26	Belt	CZN7661
*	7	Polyethylene Bag	CEG-127		27	Holder Assy	CZX3172
	8	Handle	CNC5395		28	Holder Assy	CZX3173
	9	Bush	CNV3930		29	Remote Control Assy	CZX3257
*	10	Polyethylene Bag	E36-615				
	11	Polyethylene Bag	CEG1088				
	12	Case Assy	CXB8574				
*	13	Battery	CEX1030				

**● Owner's Manual, Installation Manual**

Part No.	Language
CRD3565	English, Spanish
CRD3566	German, French
CRB3567	Italian, Dutch
CRD3568	English, Spanish, German, French, Italian, Dutch

2.2 EXTERIOR(1)

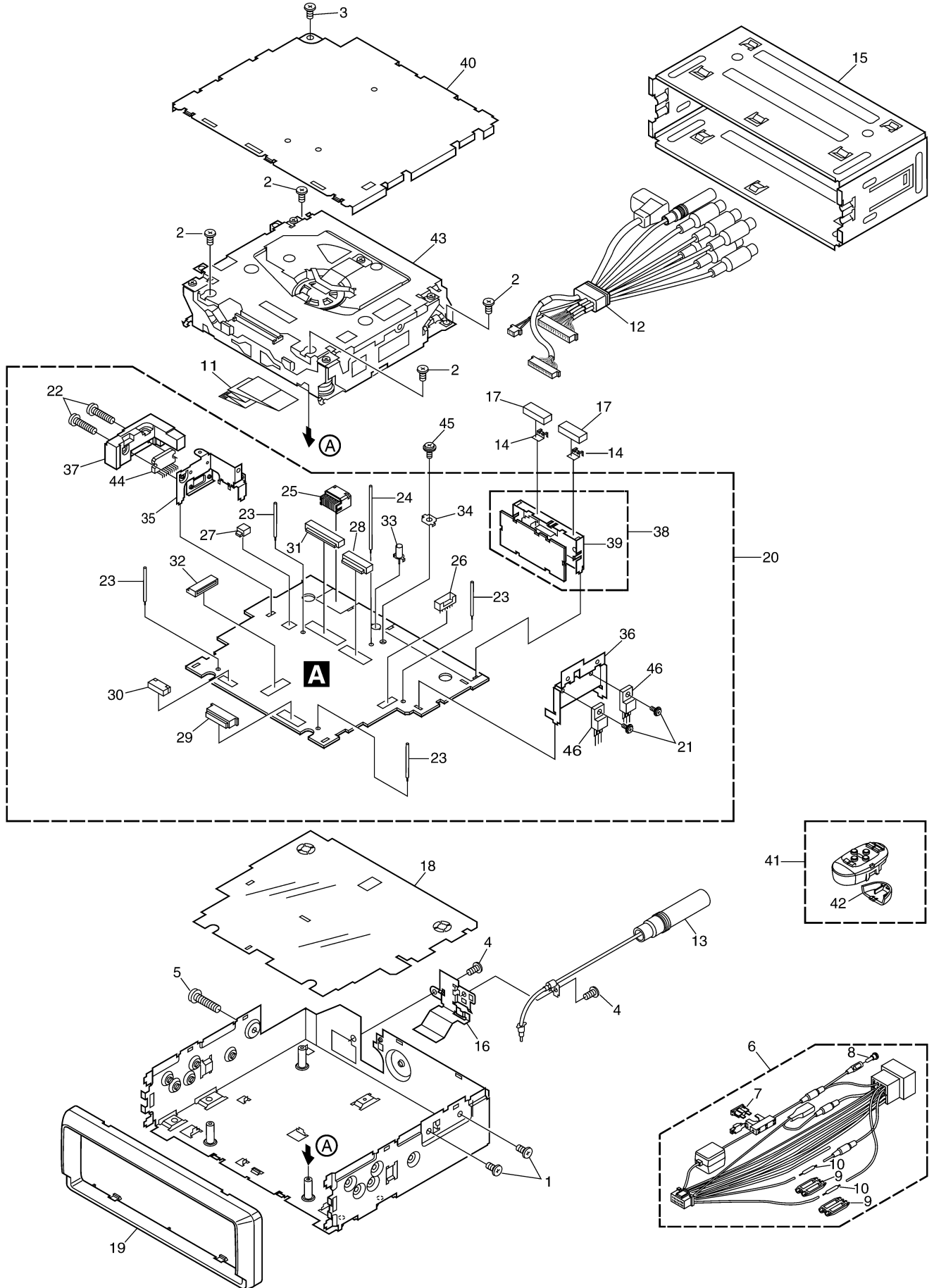

● EXTERIOR(1) SECTION PARTS LIST

Mark	No.	Description	Part No.
	1	Screw	BMZ26P040FMC
	2	Screw	BSZ26P060FMC
	3	Screw	BSZ30P050FZK
	4	Screw	BSZ30P080FMC
	5	Screw	BSZ30P160FMC
	6	Cord Assy	CDE6562
	7	Fuse(10A)	CEK1136
	8	Cap	CKX-003
	9	Cap	CNS1472
	10	Resistor	RS1/2PMF102J
	11	Flat Cable	CDE7021
	12	Cord Assy	CDE7025
	13	Antenna Cable	CDH1266
	14	Holder	CNC6469
	15	Holder	CNC8659
	16	Holder	CNC9708
	17	Cushion	CNM4870
	18	Insulator	CNM7543
	19	Panel	CNS6863
	20	Tuner Amp Unit	CWM8041
	21	Screw	ASZ26P080FMC
	22	Screw	BMZ26P140FMC
	23	Clamper	CEF1008
	24	Clamper	CEF1009
	25	Plug(CN981)	CKM1278
	26	Plug(CN811)	CKS-787
	27	Plug(CN291)	CKS1049
*	28	Plug(CN101)	CKS1058
	29	Connector(CN832)	CKS1082
*	30	Connector(CN831)	CKS2211
	31	Connector(CN351)	CKS3606
	32	Connector(CN723)	CKS3835
	33	Pin Jack(CN402)	CKX1046
	34	Holder	CNC5399
	35	Holder	CNC9711
	36	Holder	CNC9713
	37	Heat Sink	CNR1615
	38	FM/AM Tuner Unit	CWE1562
	39	Holder	CNC8815
	40	Case Unit	CXB8524
	41	Remote Control Assy	CZX3257
	42	Cover	CZN7655
	43	CD Mechanism Module(S9MP3)	CXK5556
	44	IC(IC301)	PAL007A
	45	Screw	ISS26P055FUC
	46	Transistor(Q752,921)	2SD2396

2.3 EXTERIOR(2)

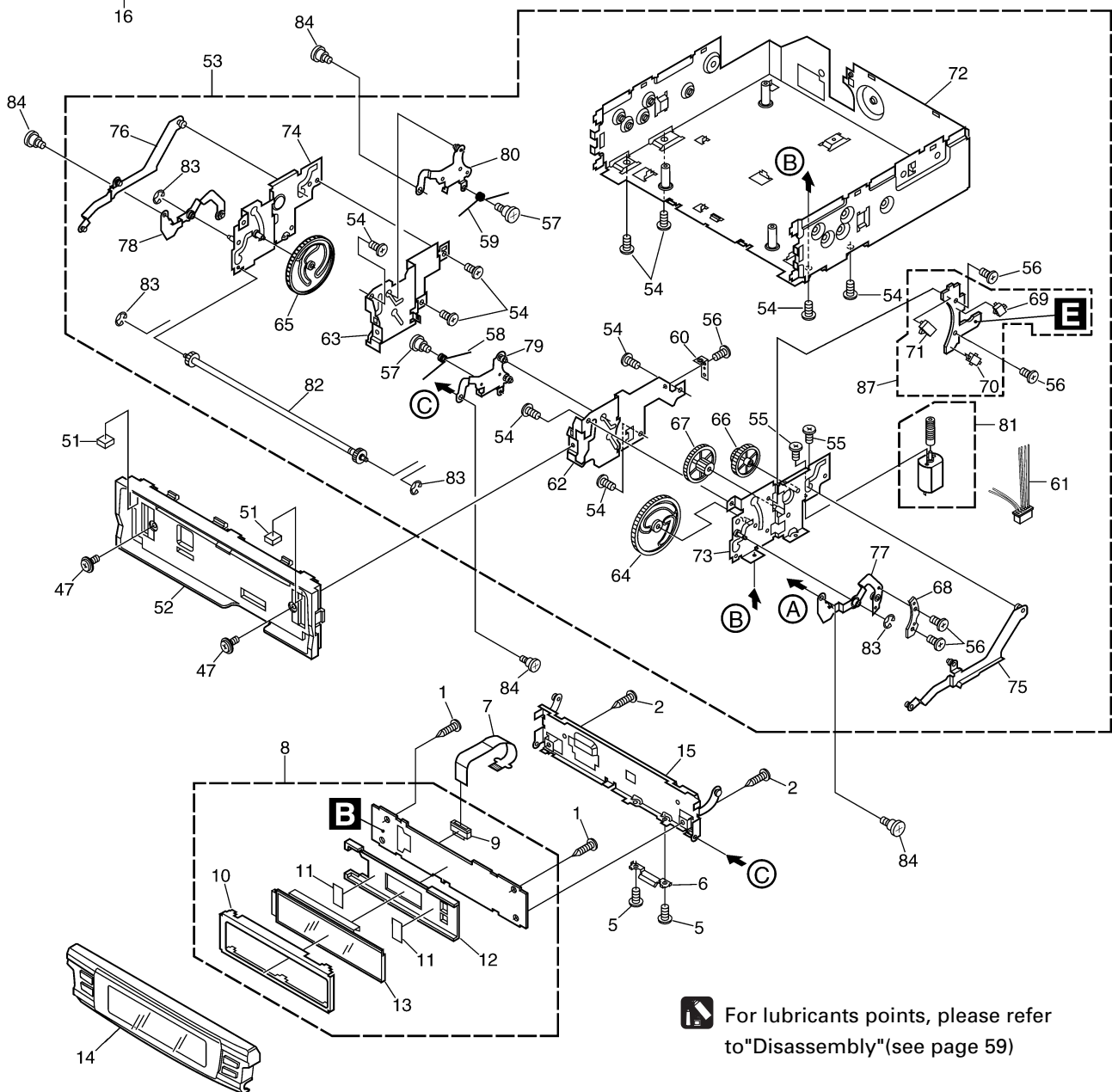
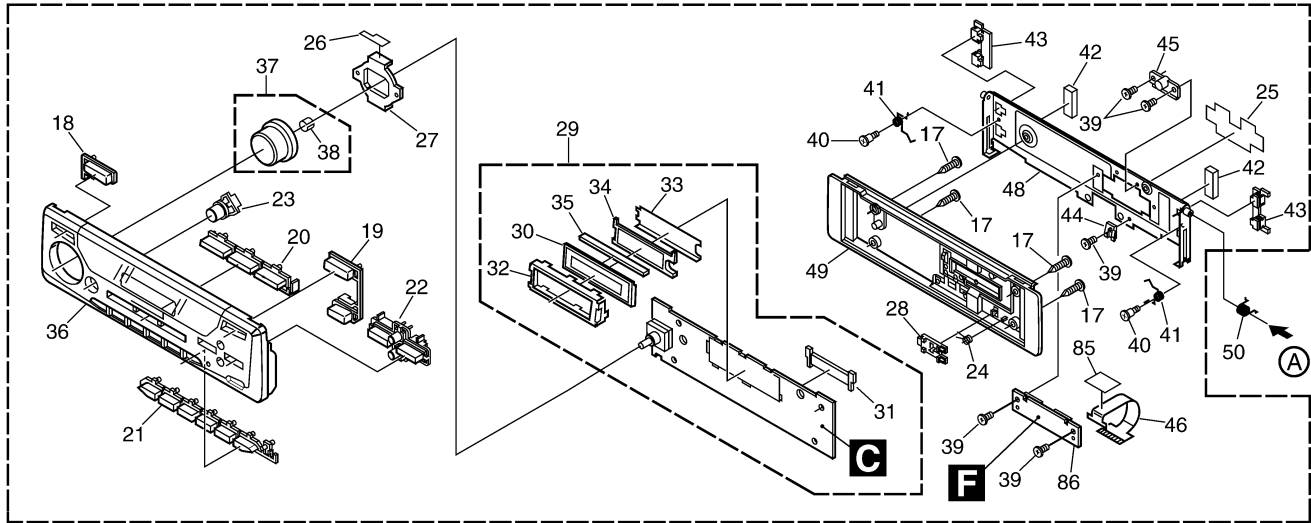



### ● EXTERIOR(2) SECTION PARTS LIST

Mark	No.	Description	Part No.	Mark	No.	Description	Part No.
	1	Screw	BPZ20P060FMC		47	Screw	ISS26P055FUC
	2	Screw	BPZ20P080FZK		48	Case Unit	CXB7968
	3,4	.....			49	Cover Unit	CXB8127
	5	Screw(M2x2)	CBA1250		50	Spring	CBH2545
	6	Holder	CNC9800		51	Cushion	CNM7550
	7	Flexible PCB	CNP6498		52	Panel Unit	CXB7953
	8	Keyboard Unit(OEL)	CWM8050		53	Drive Unit	CXB8138
	9	Connector(CN1801)	CKS4175		54	Screw	BMZ26P040FMC
	10	Holder	CNC9649		55	Screw(M2x3)	CBA1061
	11	Tape	CNM7514		56	Screw(M2x2)	CBA1250
	12	Holder	CNV6916		57	Screw(M2x1.4)	CBA1562
	13	OEL Unit	MXS8018		58	Spring	CBH2525
	14	Sub Grille Assy	CXB9361		59	Spring	CBH2526
	15	Case Unit	CXB7967		60	Spring	CBL1557
	16	Detach Grille Assy	CXB8091		61	Cord	CDE6737
	17	Screw	BPZ20P080FZK		62	Holder	CNC9678
	18	Button(EJECT)	CAC7241		63	Holder	CNC9679
	19	Button(OPEN/BAND)	CAC7242		64	Gear	CNV6932
	20	Button(SRC/TEXT/TA)	CAC7243		65	Gear	CNV6933
	21	Button(1-6)	CAC7246		66	Gear	CNV6935
	22	Button(CROSS)	CAC7247		67	Gear	CNV6936
	23	Button(EQ)	CAC7248		68	Lever	CNV6937
	24	Spring	CBH2543		69	Switch(S951)	CSN1051
	25	Insulator	CNM7649		70	Spring Switch(S952)	CSN1052
	26	Sheet	CNM7824		71	Switch(S953)	CSN1058
	27	Lighting Conductor	CNV6913		72	Chassis Unit	CXB7956
	28	Arm	CNV6963		73	Holder Unit	CXB7959
	29	Keyboard Unit(LCD)	CWM8055		74	Holder Unit	CXB7960
	30	LCD(LCD1901)	CAW1704		75	Arm Unit	CXB7961
	31	Connector(CN1901)	CKS4549		76	Arm Unit	CXB7962
	32	Holder	CNC9648		77	Arm Unit	CXB7963
	33	Sheet	CNM7512		78	Arm Unit	CXB7964
	34	Lighting Conductor	CNV6914		79	Arm Unit	CXB7965
	35	Connector	CNV6915		80	Arm Unit	CXB7966
	36	Grille Unit	CXB7940		81	Motor Unit(M951)	CXB8939
	37	Knob Assy	CXB8026		82	Gear Unit	CXB8940
	38	Spring	CBL1321		83	Washer	YE15FUC
	39	Screw(M2x2)	CBA1250		84	Screw	CBA1559
	40	Screw	CBA1561		85	Sheet	CNM7839
	41	Spring	CBH2530		86	PCB	CNX3607
	42	Cushion	CNM7551		87	Switch Unit	CWS1370
	43	Arm	CNV6962				
	44	Guide	CNV6967				
	45	Guide	CNV6968				
	46	Flexible PCB	CNP6869				

## 2.4 CD MECHANISM MODULE

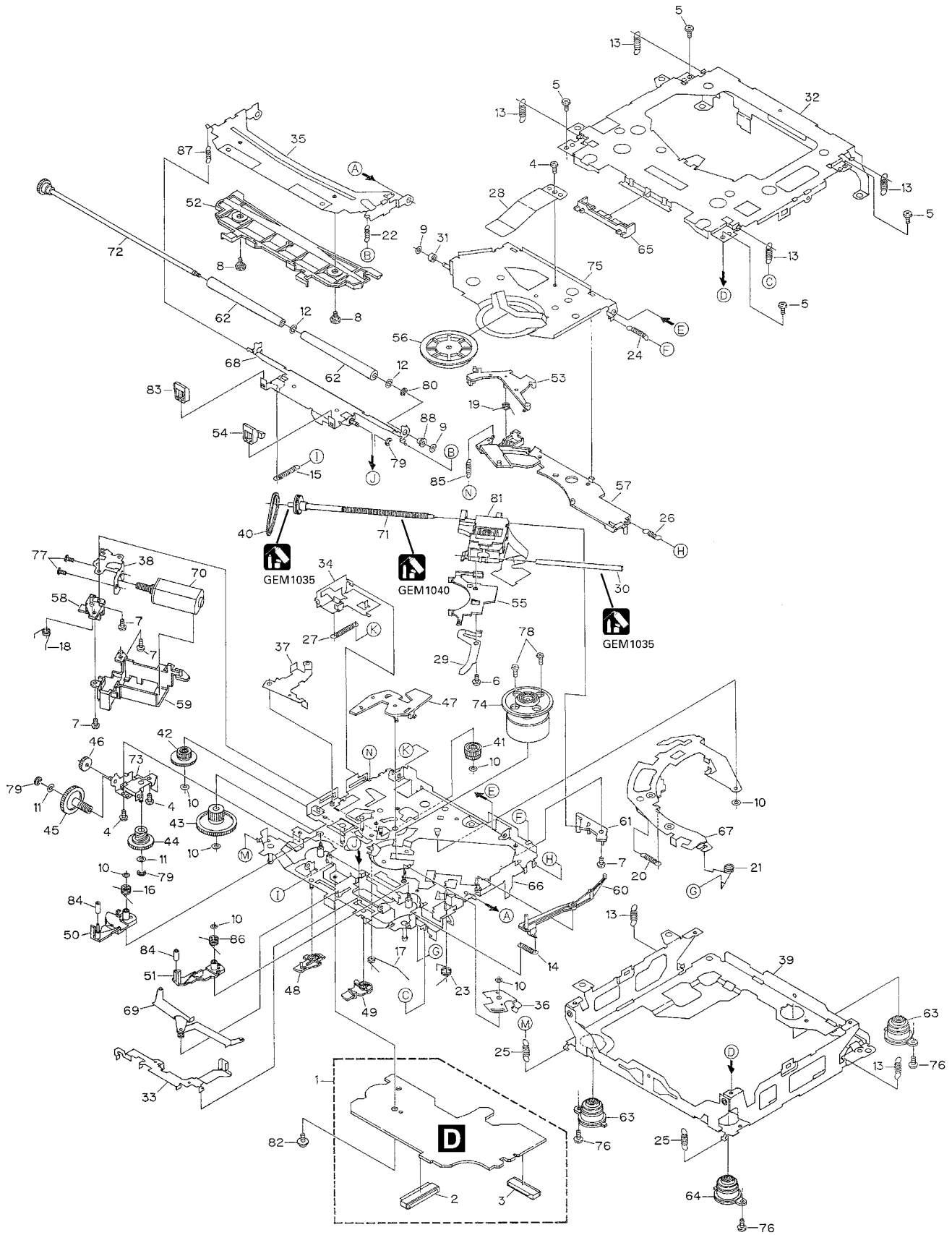

● CD MECHANISM MODULE SECTION PARTS LIST

Mark No.	Description	Part No.	Mark No.	Description	Part No.
1	CD Core Unit(S9MP3)	CWX2618	46	Gear	CNV6320
2	Connector(CN901)	CKS4188	47	Arm	CNV6322
3	Connector(CN101)	CKS3486	48	Arm	CNV6323
4	Screw	BMZ20P025FMC	49	Arm	CNV6324
5	Screw	BSZ20P040FMC	50	Arm	CNV6888
6	Screw(M2x4)	CBA1362	51	Arm	CNV6889
7	Screw(M2x3)	CBA1527	52	Guide	CNV6327
8	Screw	CBA1545	53	Arm	CNV6924
9	Washer	CBF1037	54	Guide	CNV6921
10	Washer	CBF1038	55	Rack	CNV6923
11	Washer	CBF1039	56	Clamper	CNV6331
12	Washer	CBF1060	57	Arm	CNV6332
13	Spring	CBH2378	58	Guide	CNV6333
14	Spring	CBH2379	59	Cover	CNV6334
15	Spring	CBH2514	60	Arm	CNV6335
16	Spring	CBH2533	61	Guide	CNV6336
17	Spring	CBH2382	62	Roller	CNV6338
18	Spring	CBH2383	63	Damper	CNV6175
19	Spring	CBH2384	64	Damper	CNV6662
20	Spring	CBH2527	65	Guide	CNV6925
21	Spring	CBH2386	66	Chassis Unit	CXB7980
22	Spring	CBH2537	* 67	Arm Unit	CXB7983
23	Spring	CBH2390	68	Arm Unit	CXB7984
24	Spring	CBH2391	69	Arm Unit	CXB7985
25	Spring	CBH2523	70	Motor Unit(M2)	CXB5903
26	Spring	CBH2426	71	Screw Unit	CXB5904
27	Spring	CBH2444	72	Gear Unit	CXB8076
28	Spring	CBL1561	73	Bracket Unit	CXB7982
29	Spring	CBL1553	74	Motor Unit(M1)	CXB6007
30	Shaft	CLA3845	75	Arm Unit	CXB8504
31	Roller	CLA3910	76	Screw(M2x5)	EBA1028
32	Frame	CNC9654	77	Screw	JFZ20P020FMC
33	Lever	CNC9664	78	Screw	JGZ17P020FZK
34	Lever	CNC8949	79	Washer	YE15FUC
35	Arm	CNC9661	80	Washer	YE20FUC
36	Arm	CNC9016	81	Pickup Unit(Service)(P9MP3)	CXX1550
37	Arm	CNC9017	82	Screw	IMS26P030FMC
38	Bracket	CNC9123	83	Guide	CNV6922
39	Frame	CNC9656	84	Roller	CNV6887
40	Belt	CNT1086	85	Spring	CBH2509
41	Gear	CNV6886	86	Spring	CBH2512
42	Gear	CNV6316	87	Spring	CBH2536
43	Gear	CNV6317	88	Collar	CNV6906
44	Gear	CNV6318			
45	Gear	CNV6319			

### 3. BLOCK DIAGRAM AND SCHEMATIC DIAGRAM

#### 3.1 BLOCK DIAGRAM

A

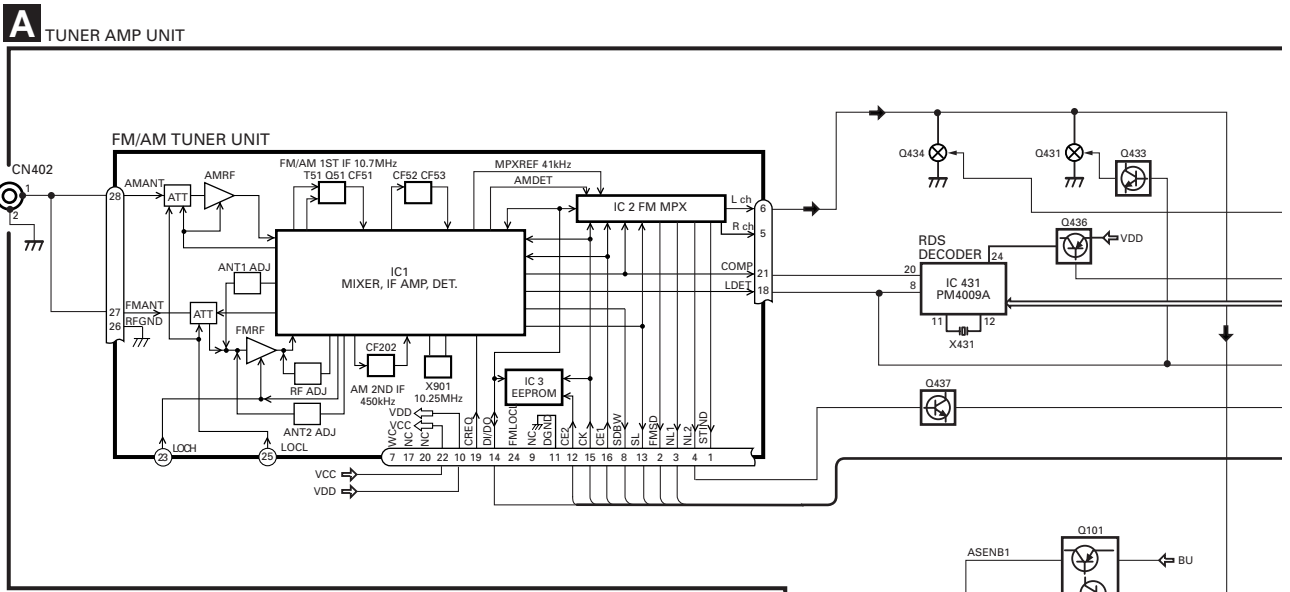

B

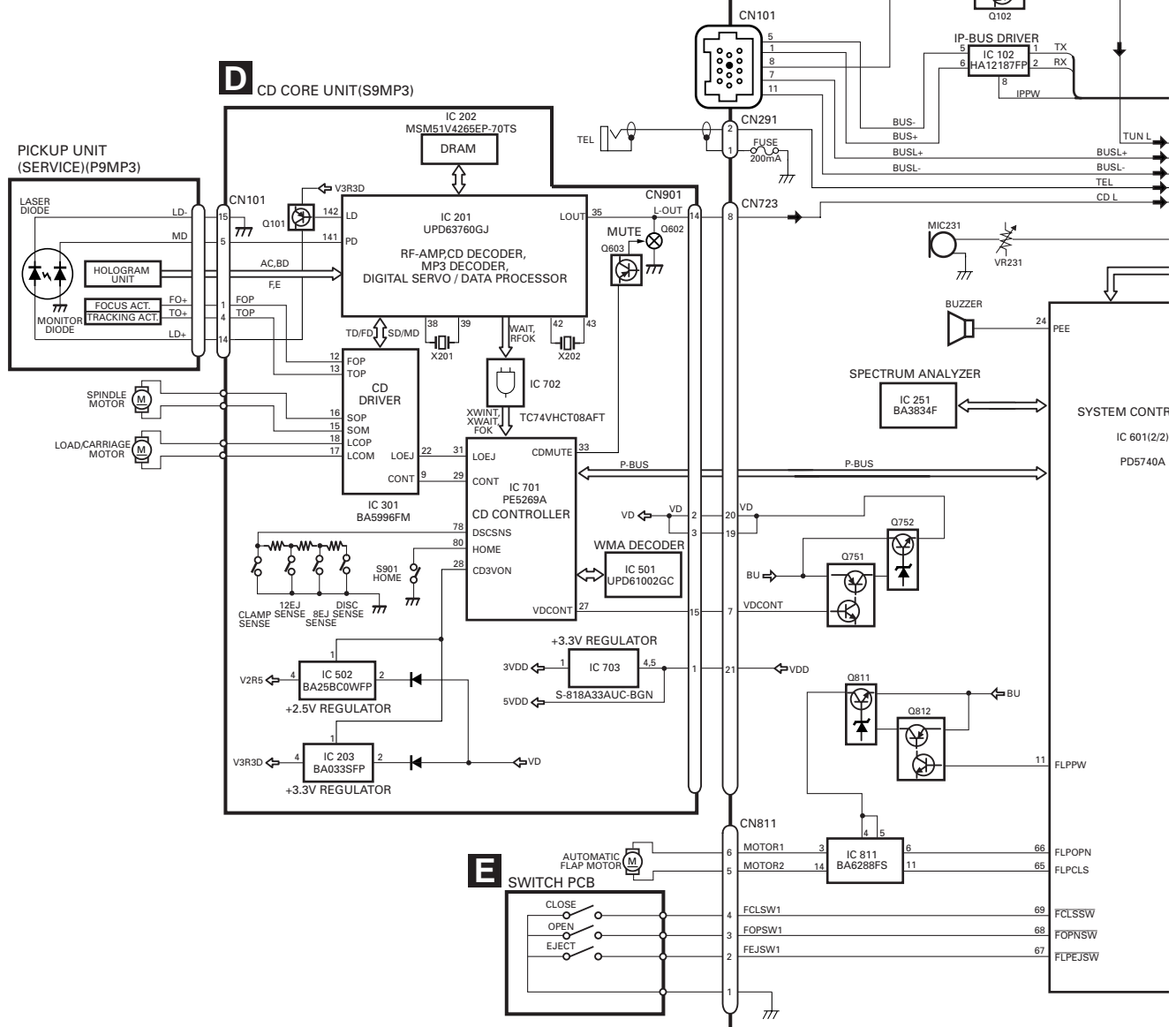

C

D

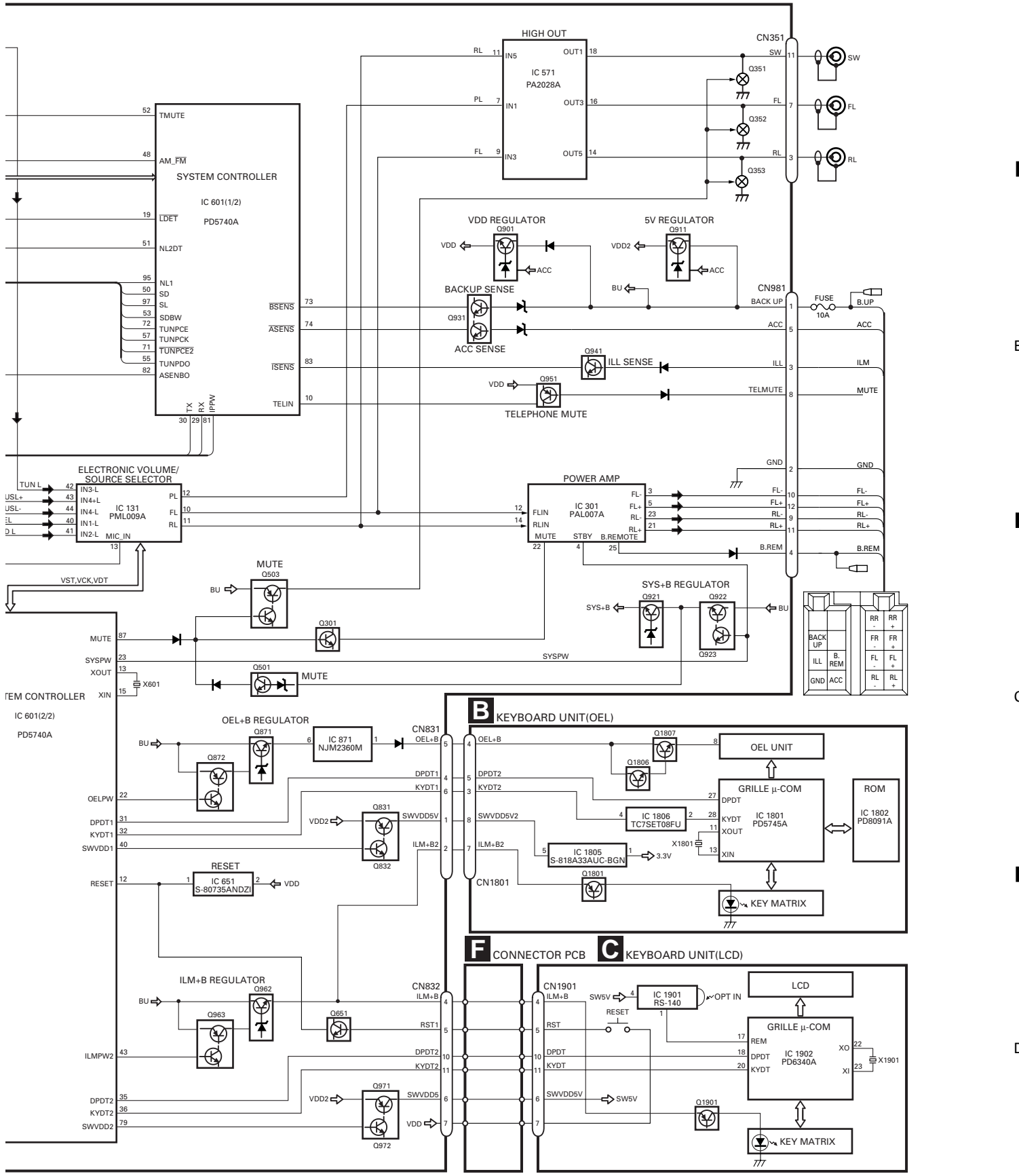

A

B

C

D

### 3.2 OVERALL CONNECTION DIAGRAM(GUIDE PAGE)

Note: When ordering service parts, be sure to refer to "EXPLODED VIEWS AND PARTS LIST" or "ELECTRICAL PARTS LIST".

# A-a

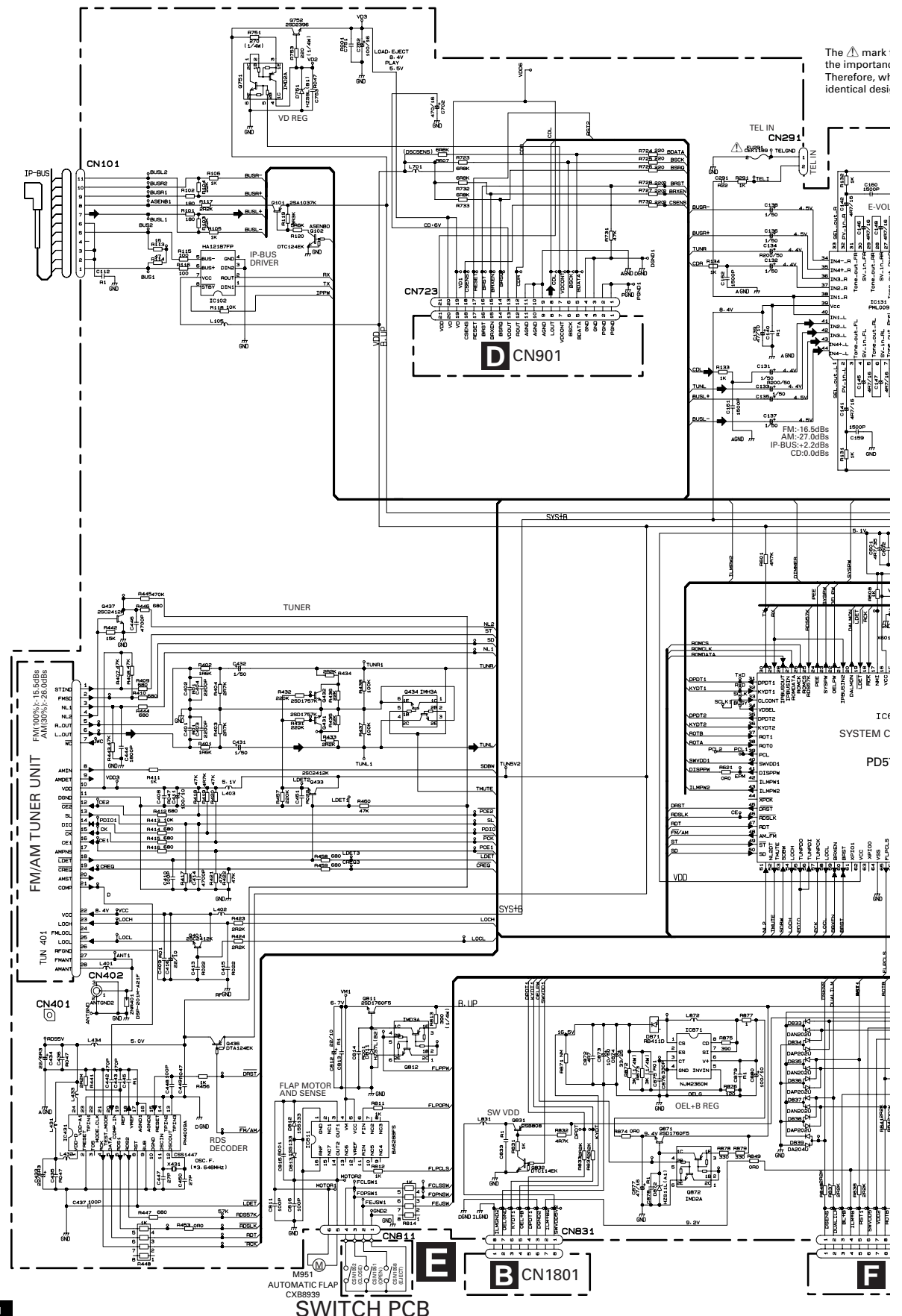
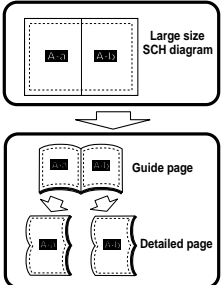

The  $\Delta$  mark: the important Therefore, with identical desi

A

B

C

D



# A-b

found on some component parts indicates  
 ice of the safety factor of the part.  
 hen replacing, be sure to use parts of  
 igation.

## A TUNER AMP UNIT

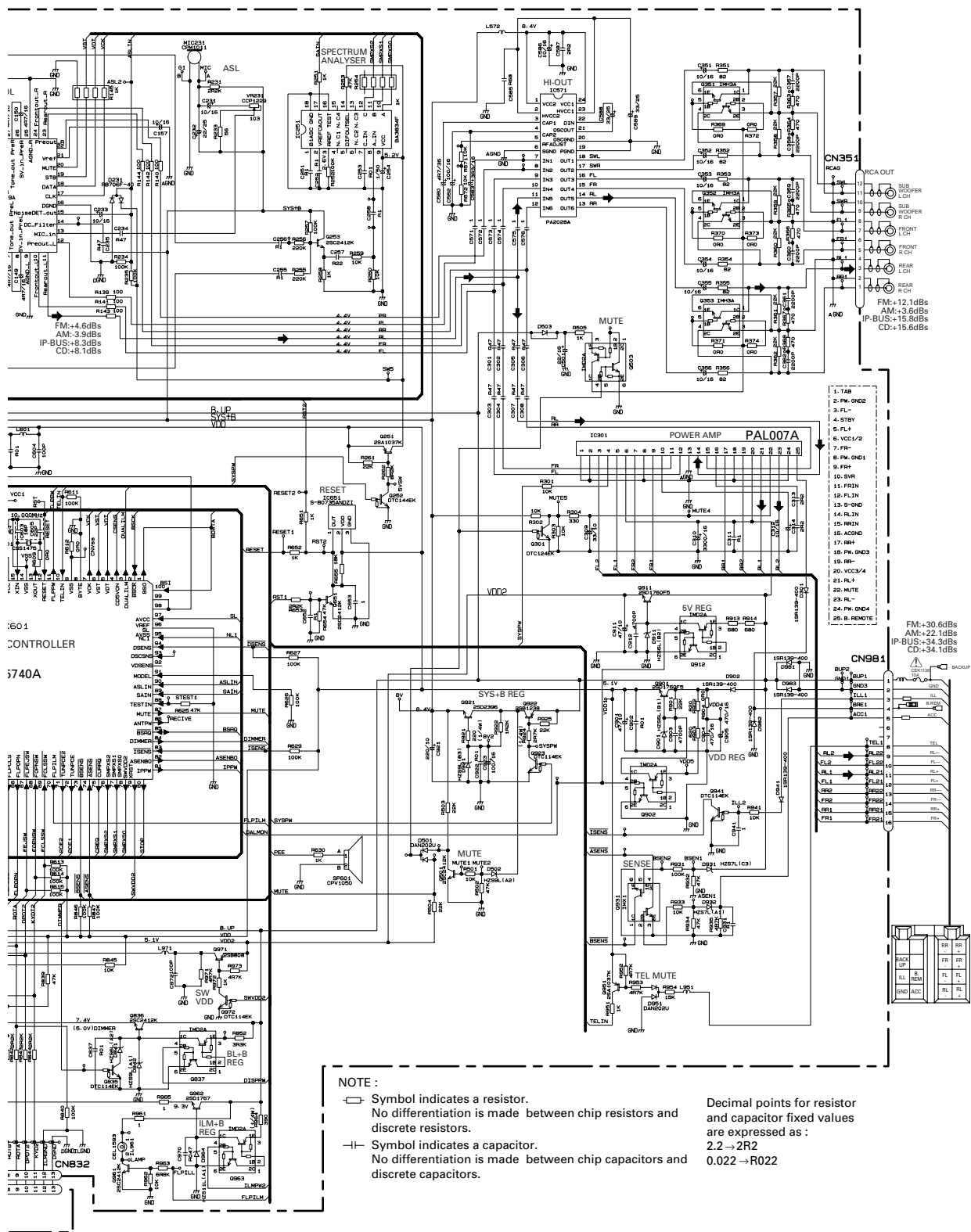

**NOTE :**  
 □ Symbol indicates a resistor.  
 No differentiation is made between chip resistors and discrete resistors.  
 □ Symbol indicates a capacitor.  
 No differentiation is made between chip capacitors and discrete capacitors.

Decimal points for resistor and capacitor fixed values are expressed as :  
 2.2 → 2R2  
 0.022 → R022



A

B

C

D

A-a A-b

The  $\Delta$  ma the import: Therefore, identical dt

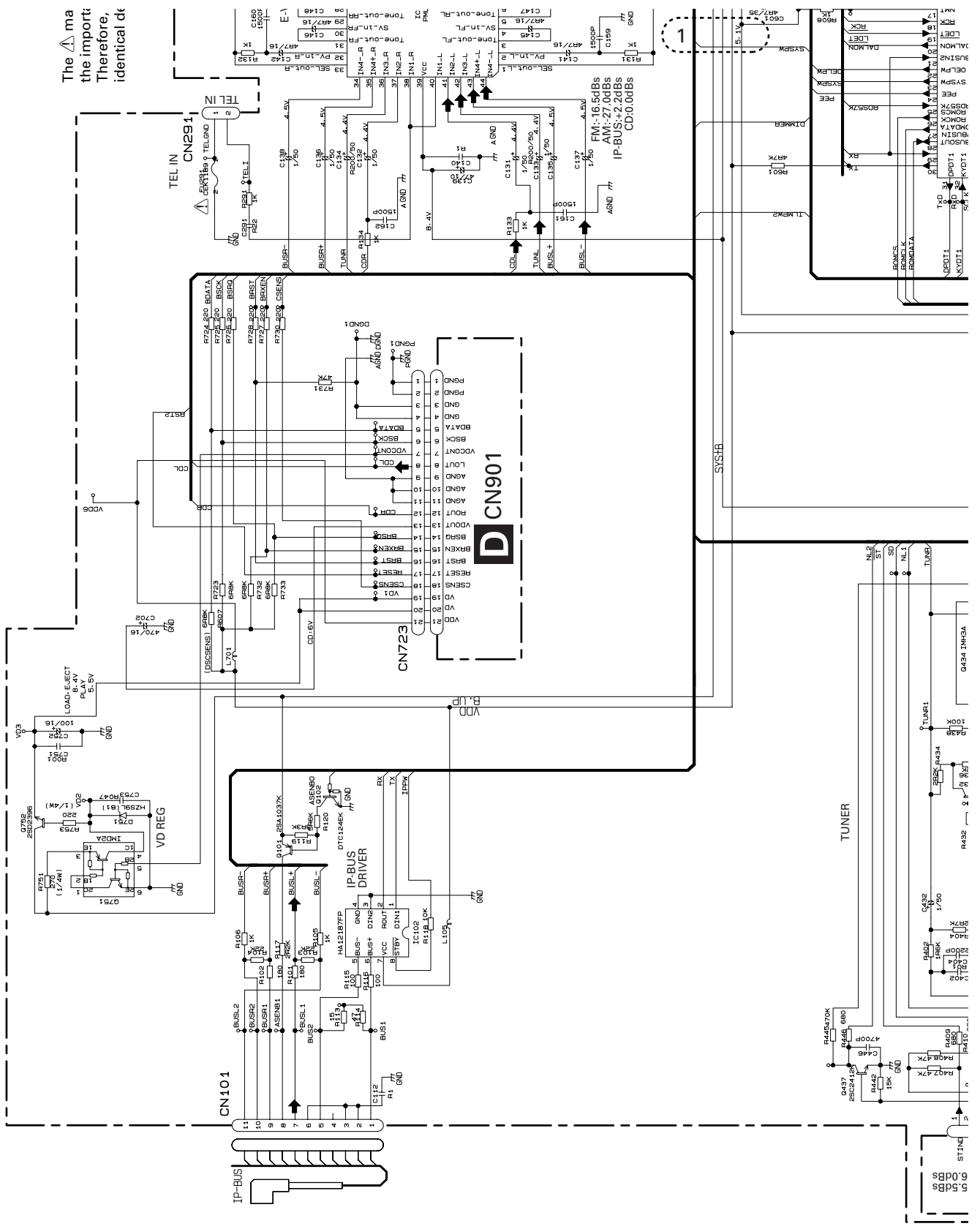



A-a A-b

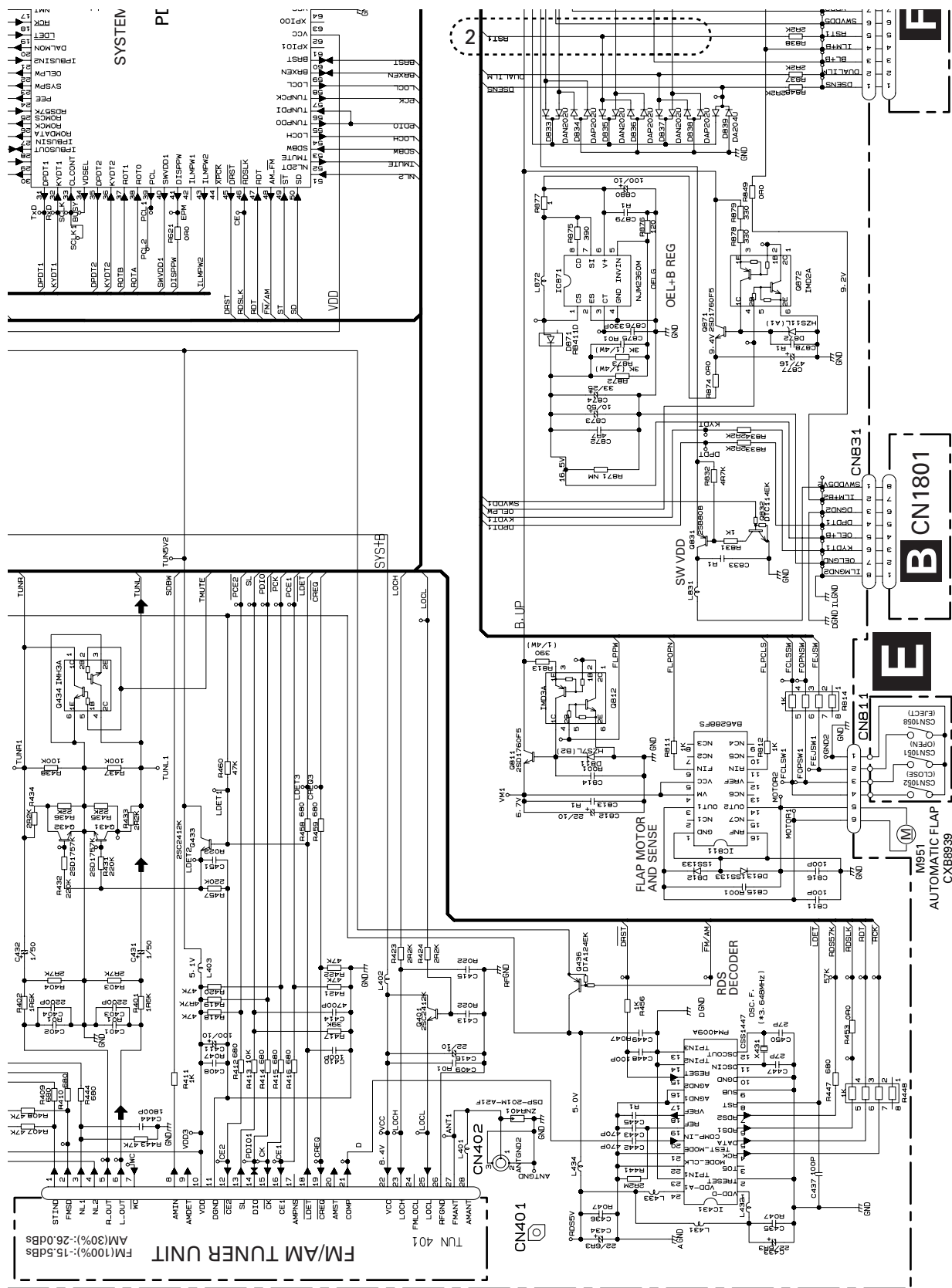

A-a E

# A TUNER AMP UNIT

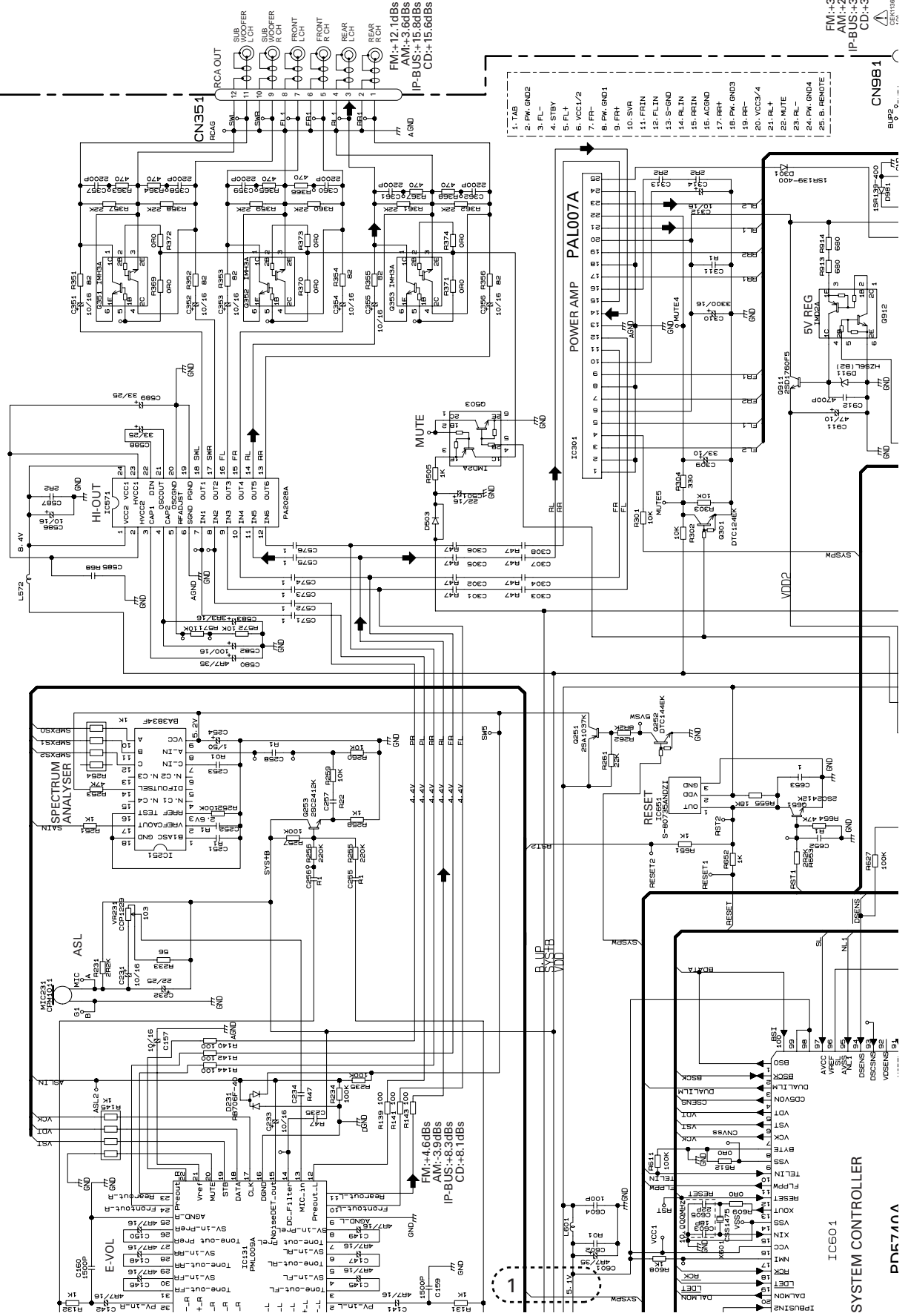

3  $\Delta$  mark found on some component parts indicates importance of the safety factor of the part. Before replacing, be sure to use parts of identical designation.

A-a A-b

FM:~30.6dBs  
 AM:~22.1dBs  
 IP-BUS:~34.30dBs  
 CD:~34.1dBs



SYSTEM CONTROLLER  
 IC601  
 PD5740A

CN981  
 BIPOLAR...

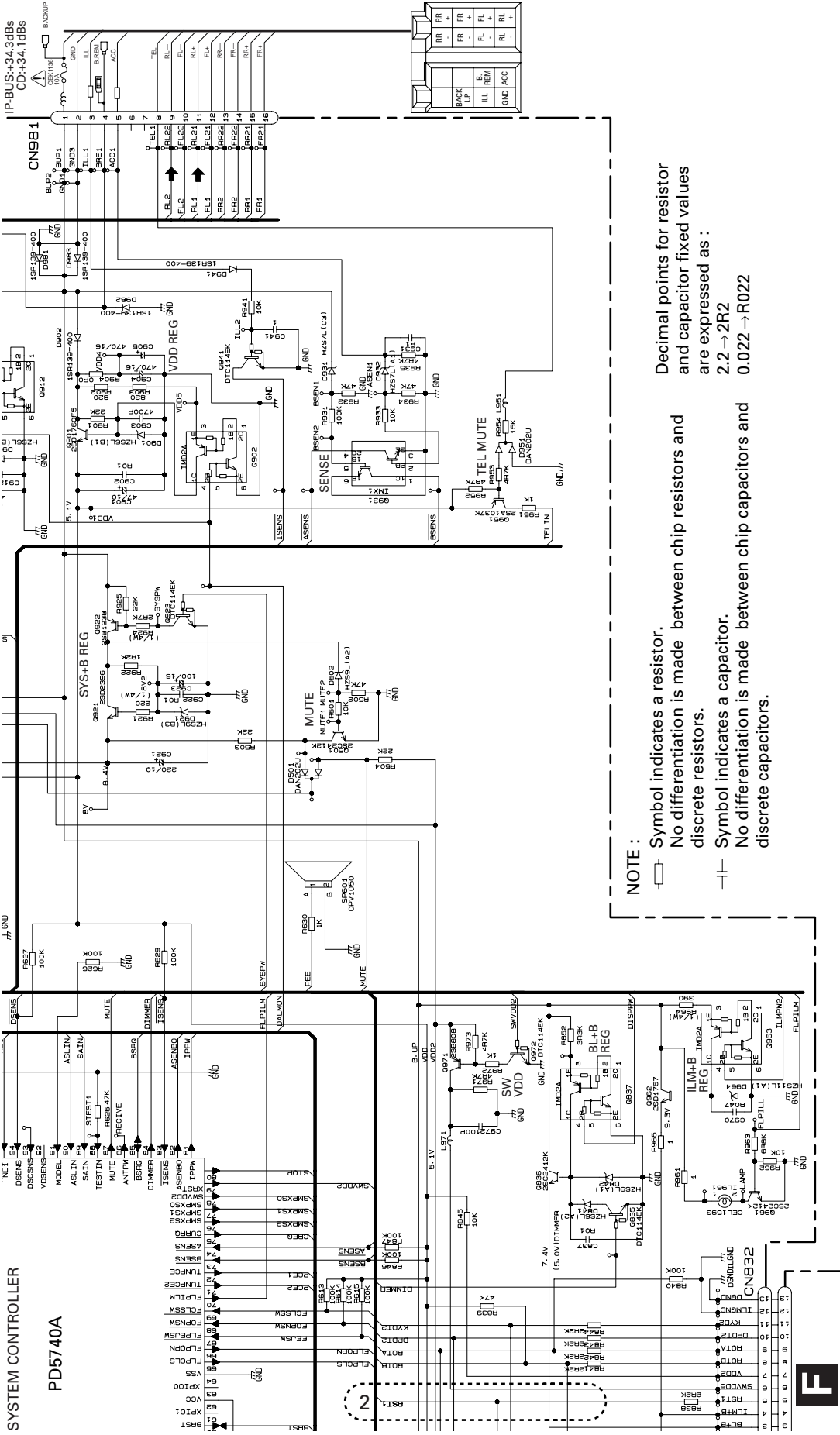
BACKUP  
 CAPACITOR



**NOTE :**

-  Symbol indicates a resistor. No differentiation is made between chip resistors and discrete resistors.
-  Symbol indicates a capacitor. No differentiation is made between chip capacitors and discrete capacitors.

Decimal points for resistor and capacitor fixed values are expressed as:  
 2.2 → 2R2  
 0.022 → R022

A-a A-b

A

B

C

D

F

A-b

3.3 KEYBOARD UNIT(OEL)

A

B

C

D

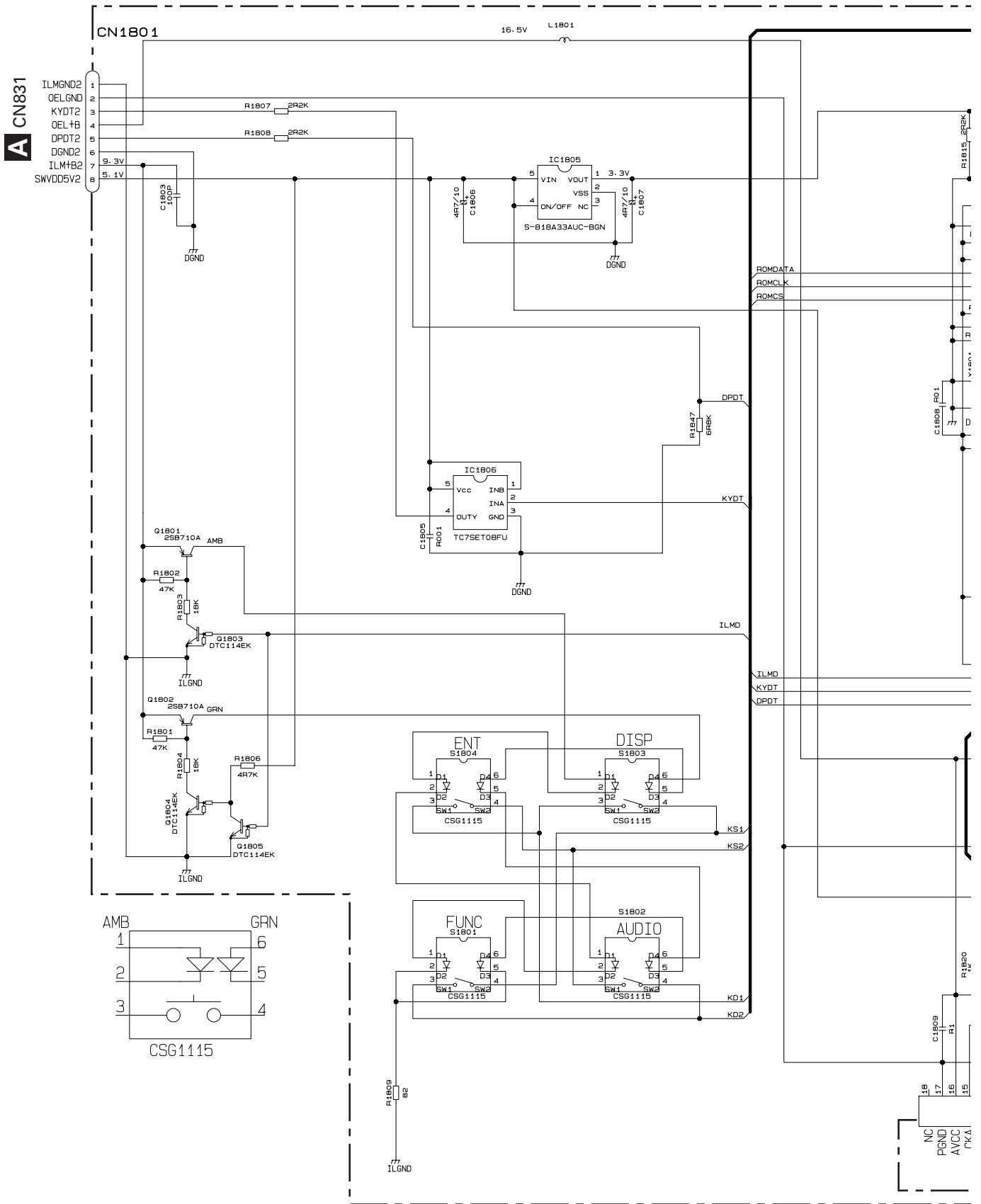

1

2

3

4

**B** KEYBOARD UNIT(OEL)

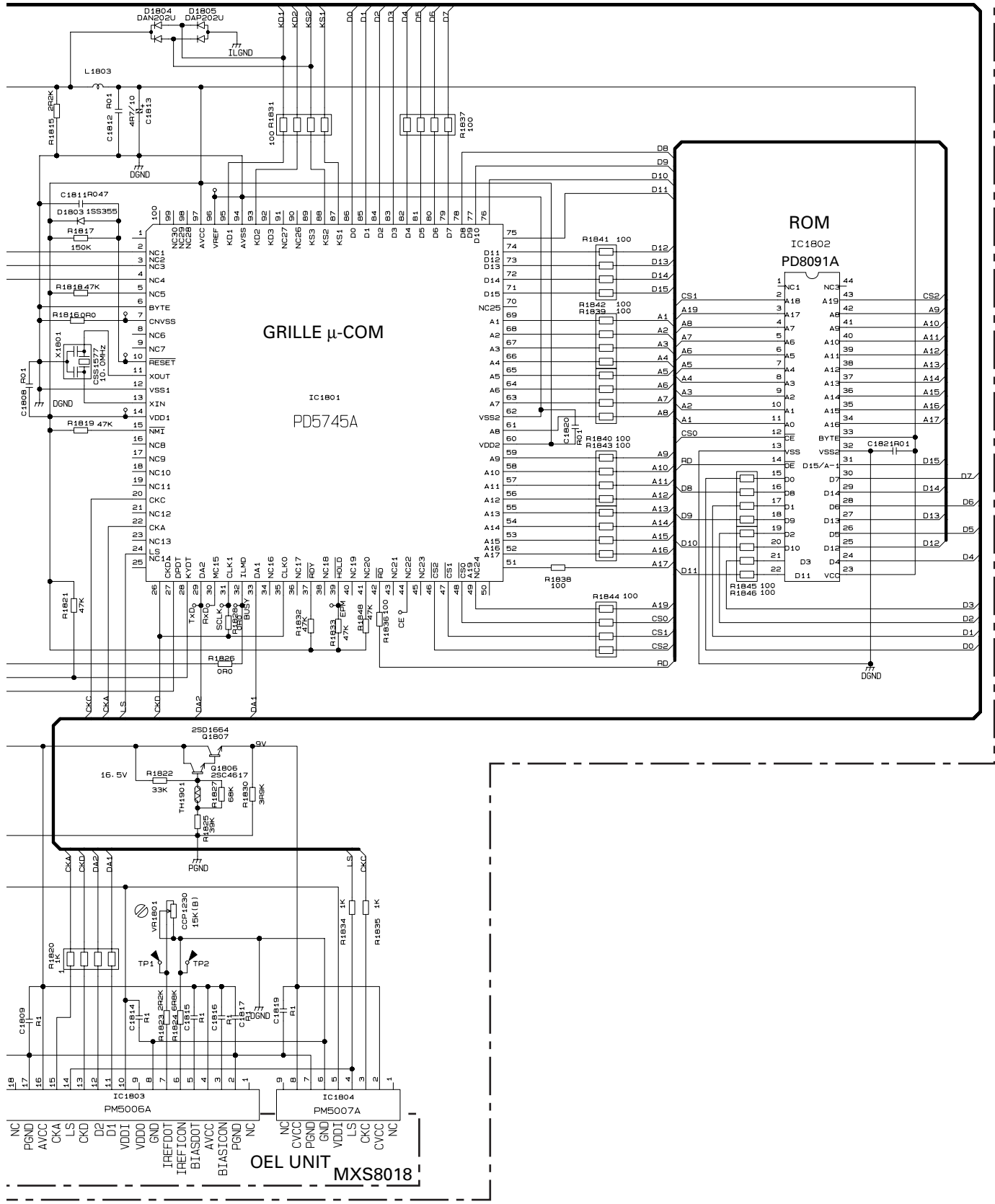

3.4 KEYBOARD UNIT(LCD)

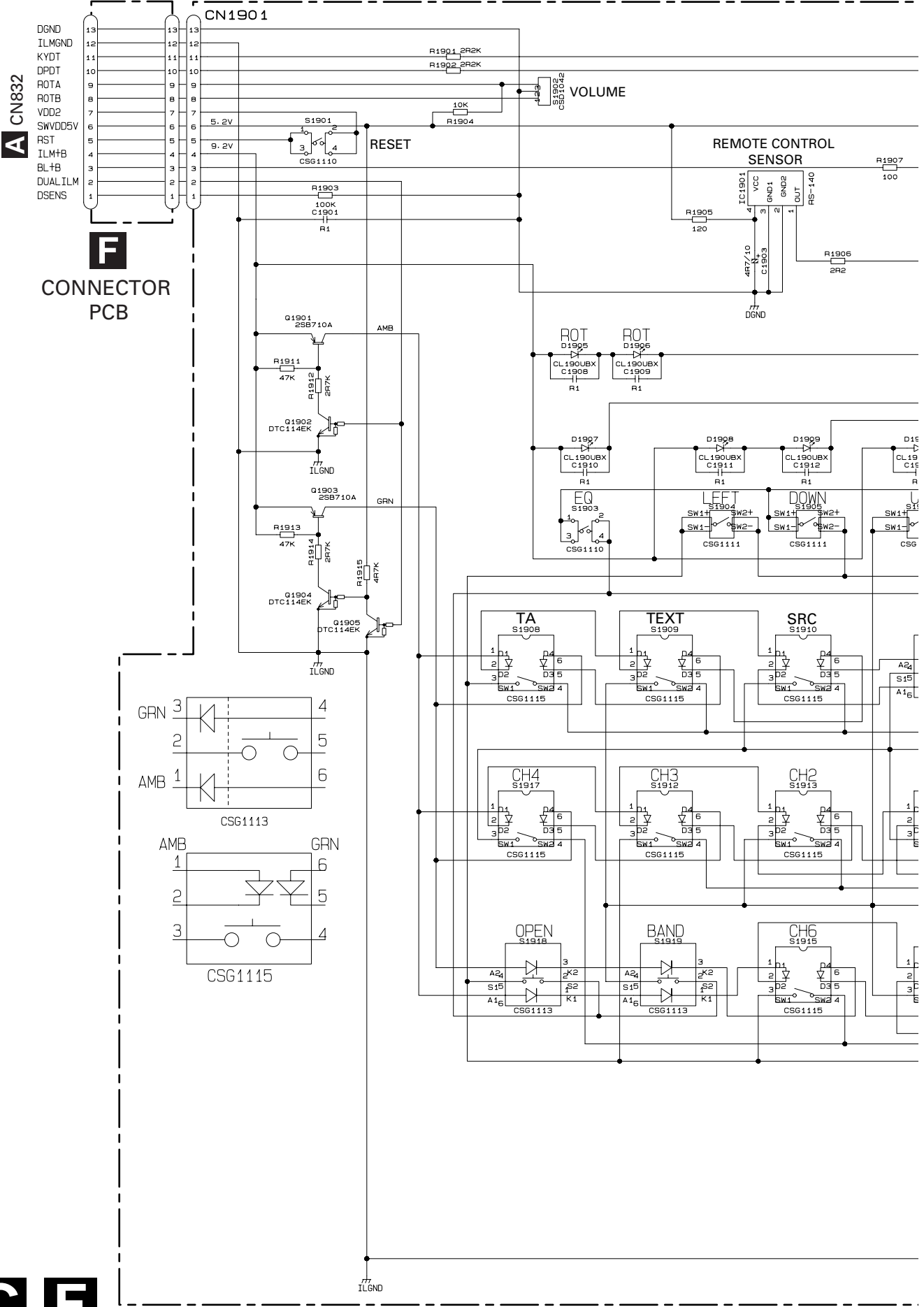

**C** KEYBOARD UNIT(LCD)

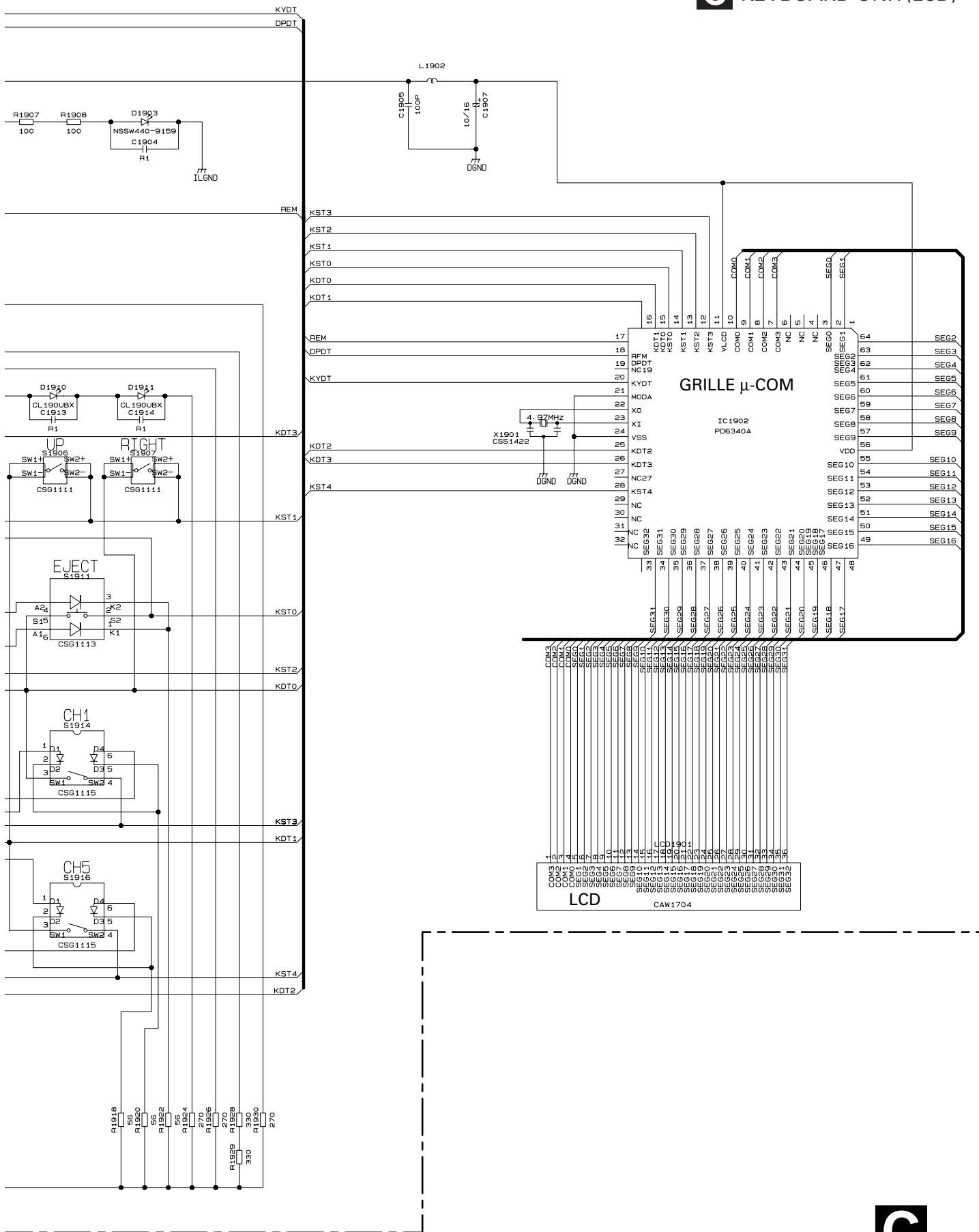

A

B

C

D



D-a

- SIGNAL LINE
- FOCUS SERVO LINE
- TRACKING SERVO LINE
- CARRIAGE SERVO LINE
- SPINDLE SERVO LINE

A

B

C

D

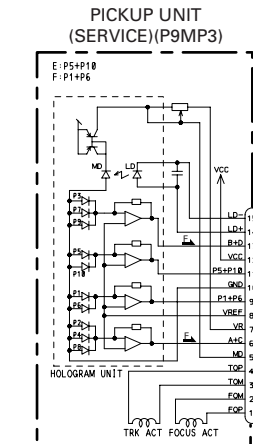

F. ACT: Applying positive voltage to FOP, the lens moves DIST. slides.  
 T. ACT: Applying positive voltage to TOP, the lens moves outer circumference.

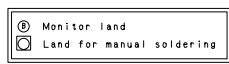

SWITCHES:  
 CD CORE UNIT(S9MP3)  
 S901: HOME SWITCH ..... ON-OFF  
 S902: CLAMP SWITCH ..... ON-OFF  
 S903: DSCSNS SWITCH ..... ON-OFF  
 S904: 12EJ SWITCH ..... ON-OFF  
 S905: BEJ SWITCH ..... ON-OFF  
 The underlined indicates the switch position.

MOTOR DRIVER LOGIC TABLE

	LOAD	EJ	PLAY	OFF
CLCONT	H	H	L	L
LOEJ	L	H	L	-
CONT	L	L	H	L

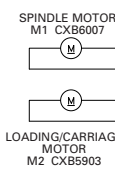



D-b

D CD CORE UNIT (S9MP3)

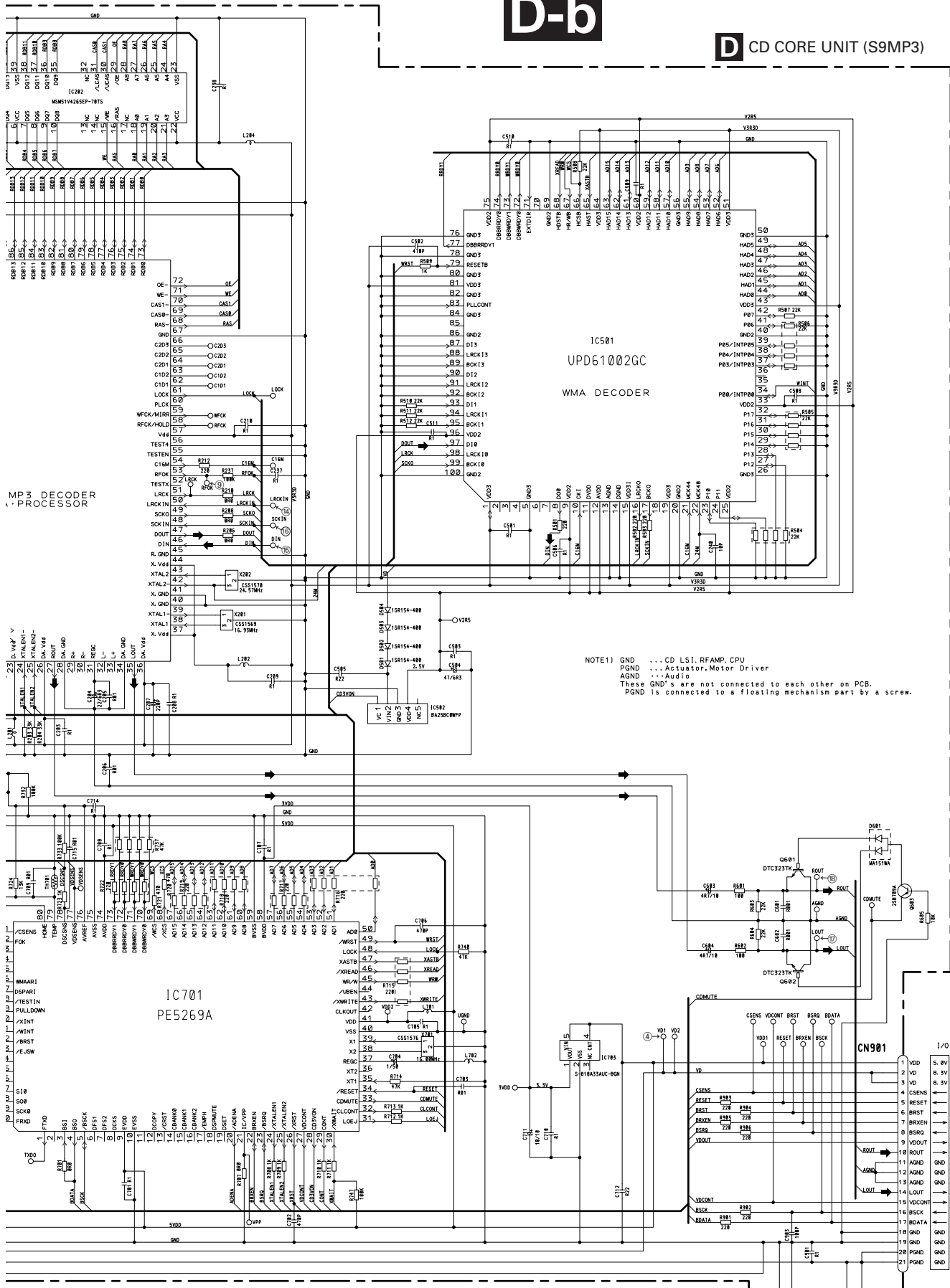

NOTE1) GND ... CD LSI, RFAMP, CPU  
 PGND ... Actuator, Motor Driver  
 AEND ... Audio  
 These GND's are not connected to each other on PCB.  
 PGND is connected to a floating mechanism part by a screw.

A CN723

D

A

D-a D-b

B

C

D

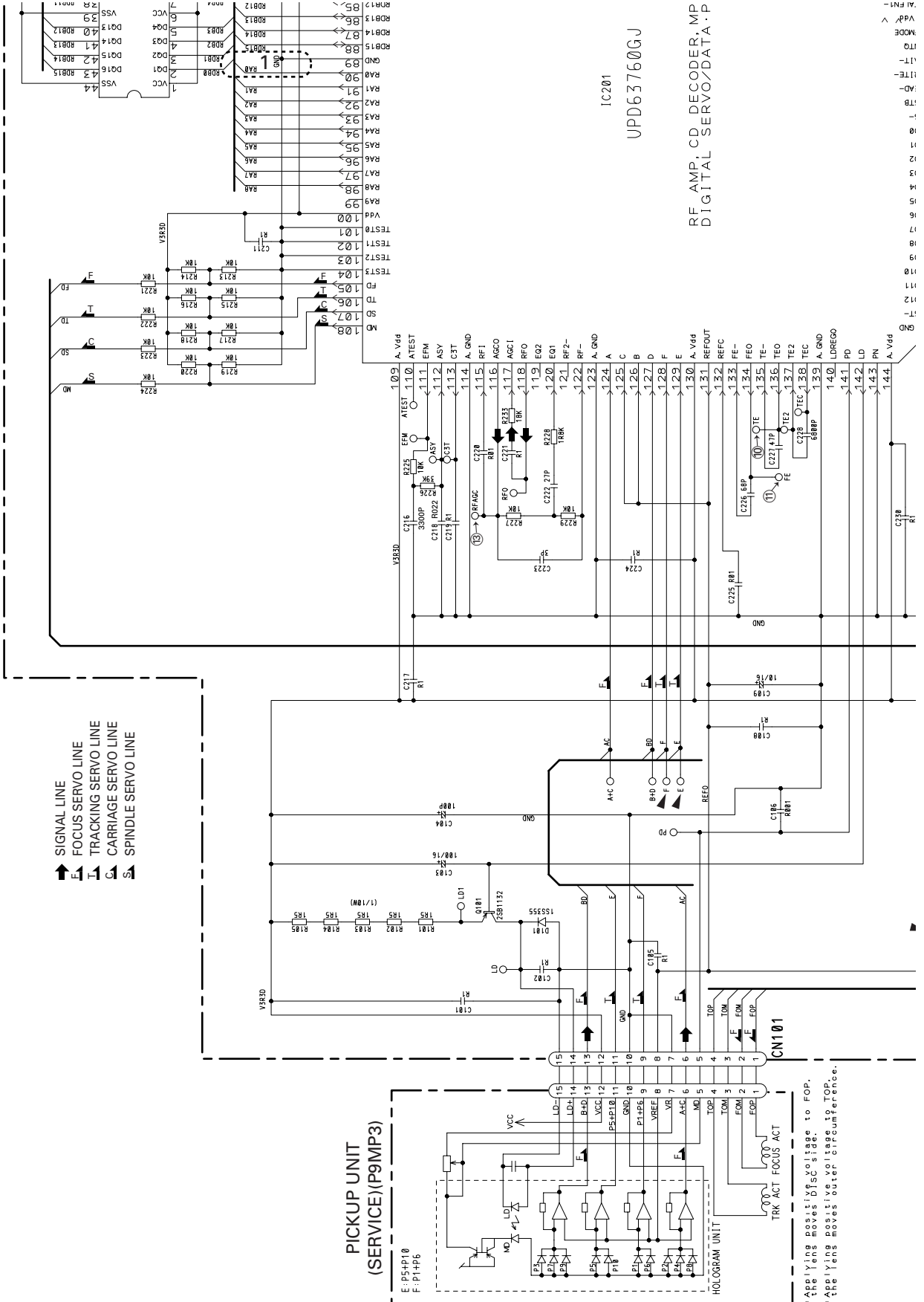

D-a D-b

A

B

C

D

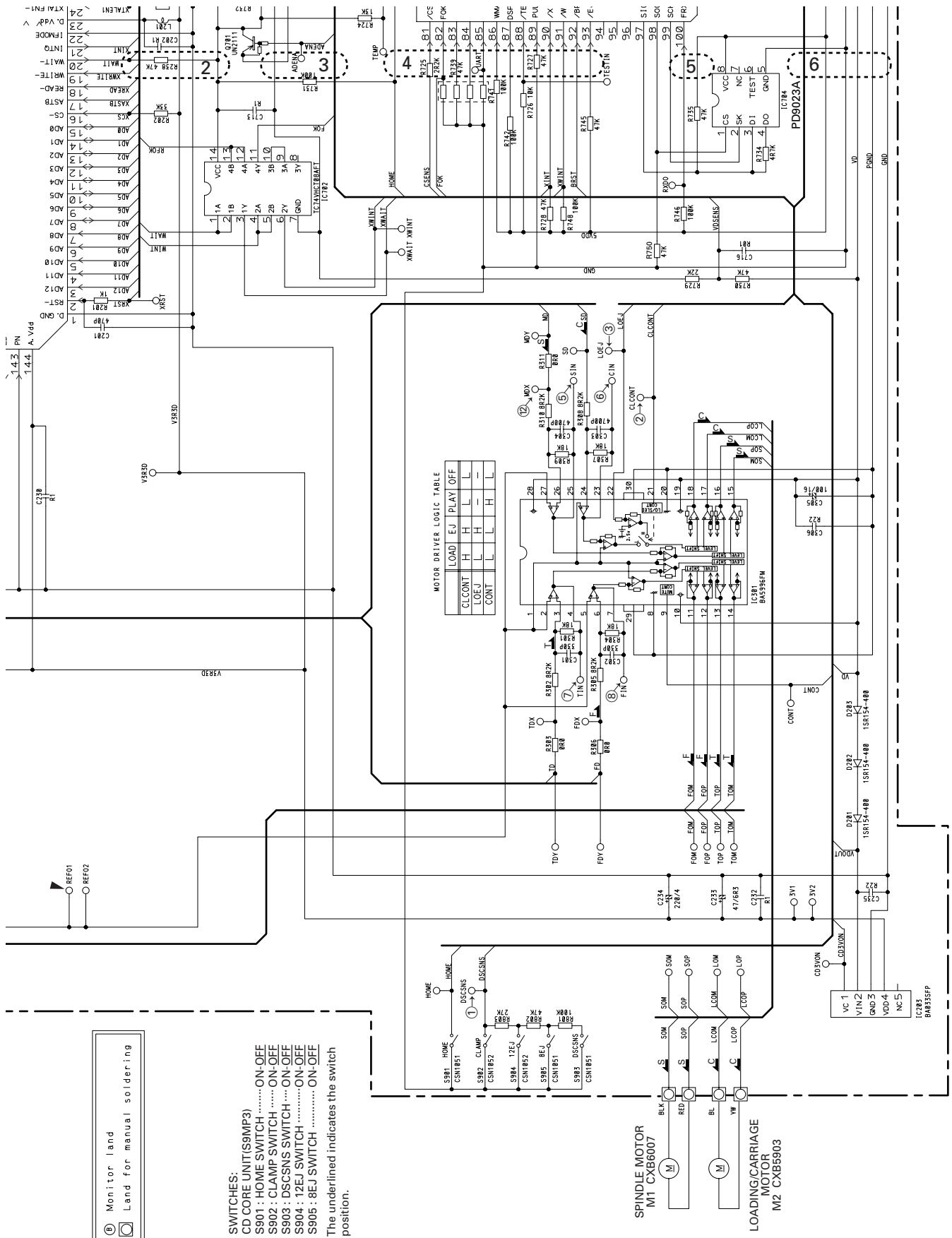

MOTOR DRIVER LOGIC TABLE

	LOAD	EJ	PLAY	OFF
CLCONT	H	H	L	L
LOEJ	L	H	H	-
CONT	L	L	H	L

**SWITCHES:**  
 CD CORE UNIT(SSMP3)  
 S901 : HOME SWITCH .....ON-OFF  
 S902 : CLAMP SWITCH .....ON-OFF  
 S903 : DSCNS SWITCH .....ON-OFF  
 S904 : 12EJ SWITCH .....ON-OFF  
 S905 : 8EJ SWITCH .....ON-OFF

The underlined indicates the switch position.

Ⓜ Monitor land  
 Ⓞ Land for manual soldering

SPINDLE MOTOR  
M1 CXB6007

LOADING/CARRIAGE  
MOTOR  
M2 CXB5903



NOTE1) GND ...CD LSI..RFAMP..CPU  
 PGND ...Actuator..Motor Driver  
 AGND ...Audio  
 These GND's are not connected to each other on PCB.  
 PGND is connected to a floating mechanism part by a screw.

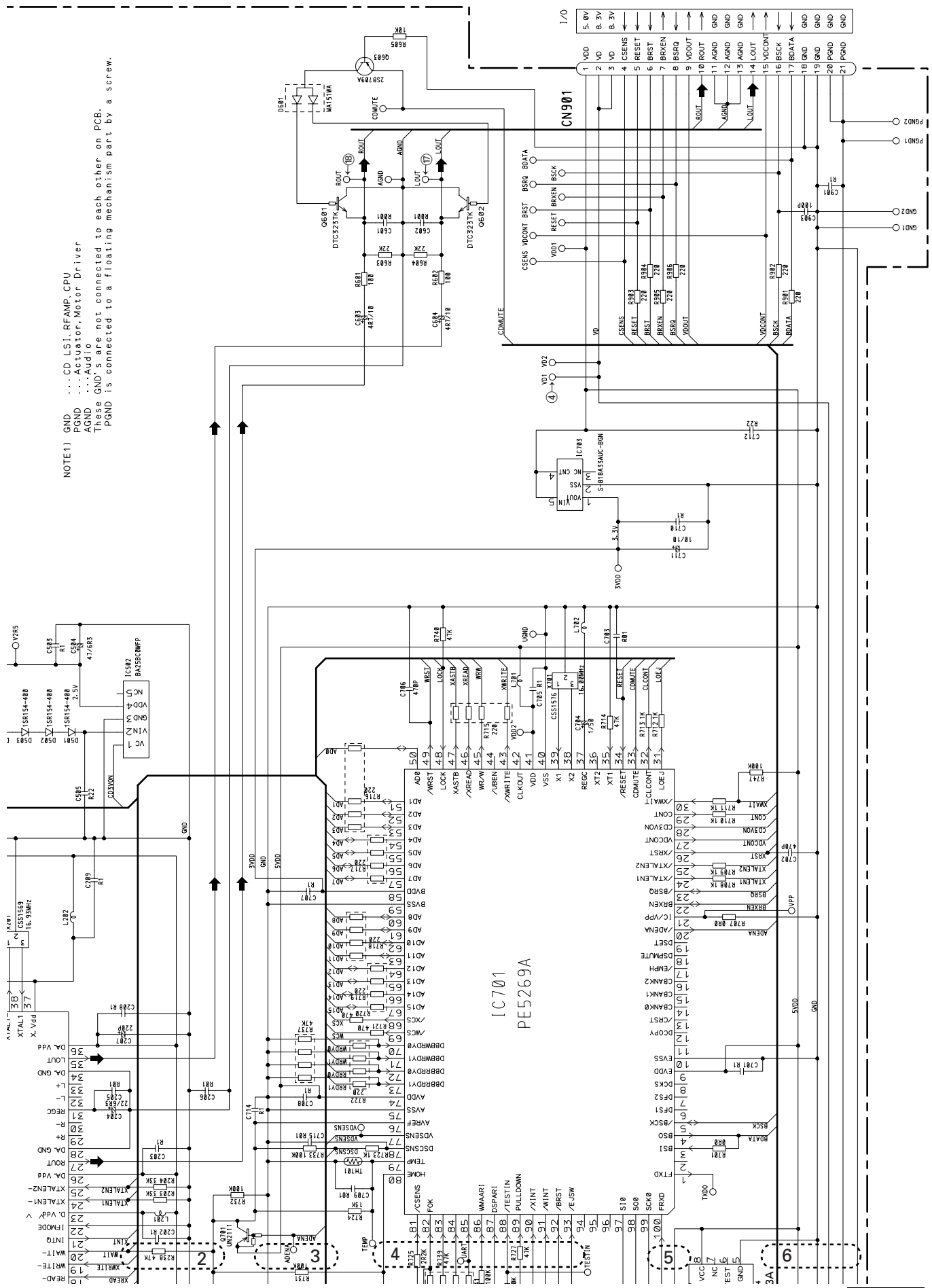

D-a D-b

D-a D-b

D-a D-b

D-a D-b

D-b

Note:1. The encircled numbers denote measuring points in the circuit diagram.  
 2. Reference voltage  
 REFO1 : 1.65V

● Waveforms

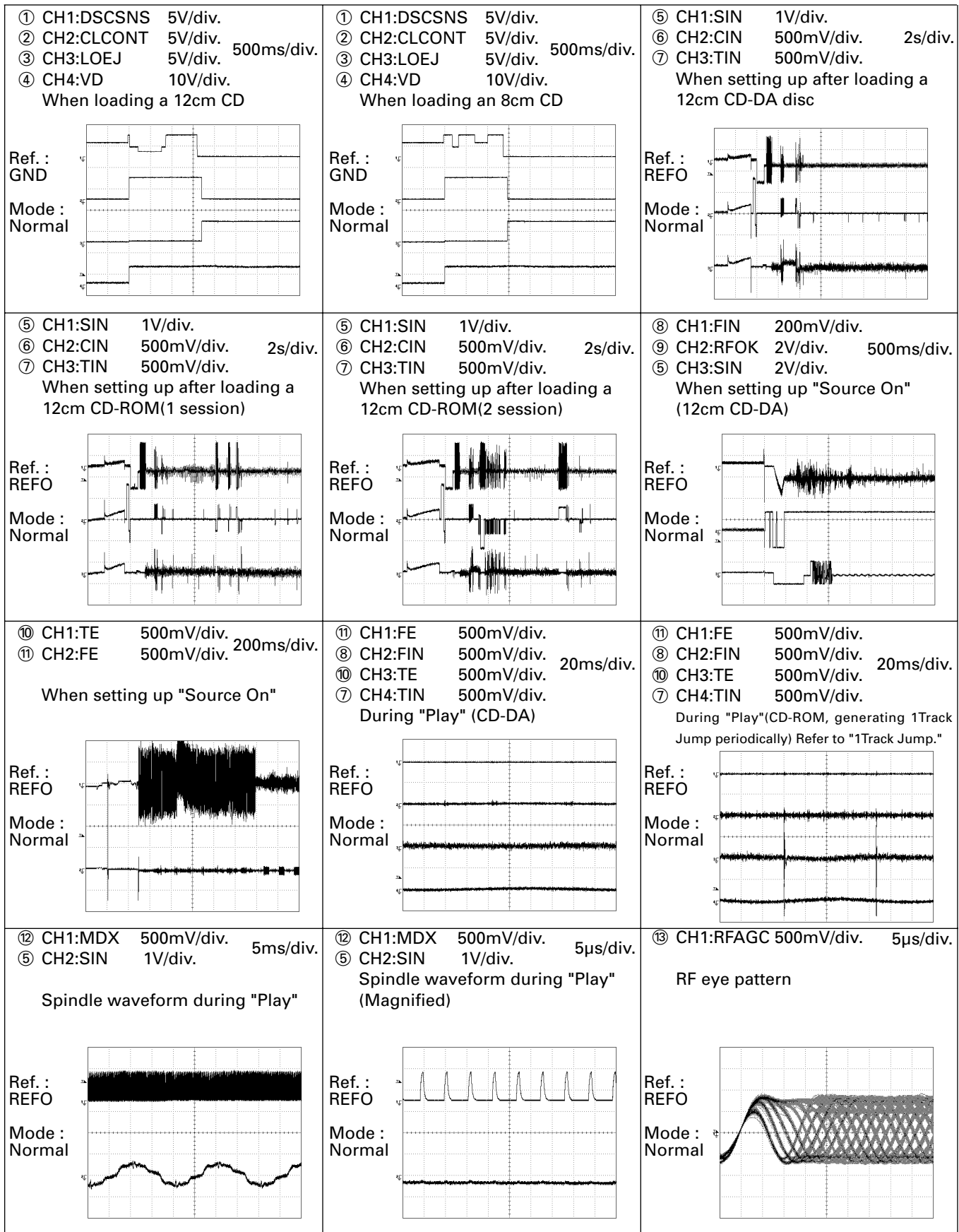

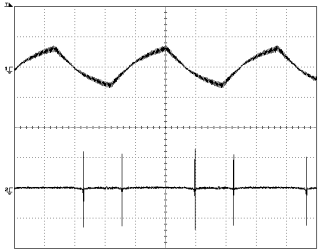
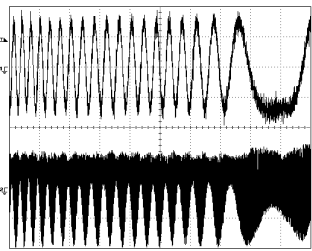
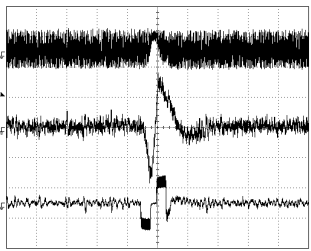
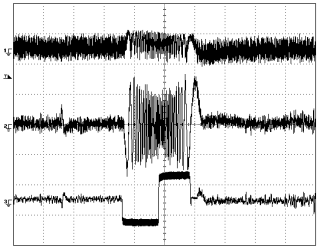
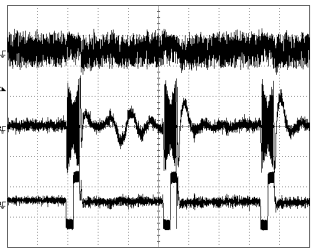
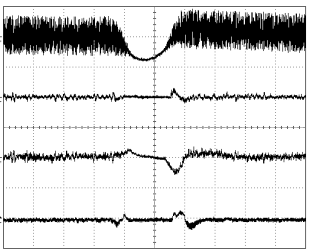
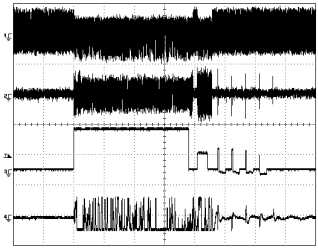
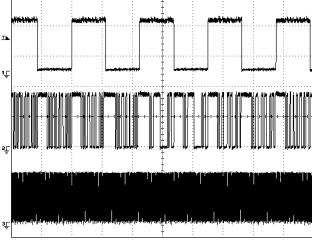
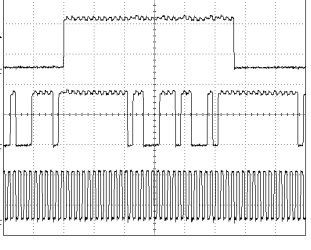
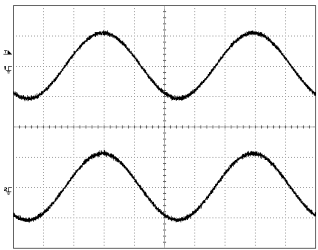
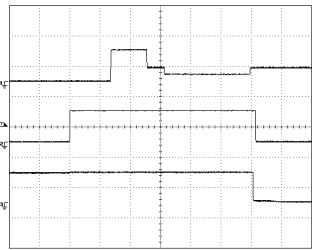
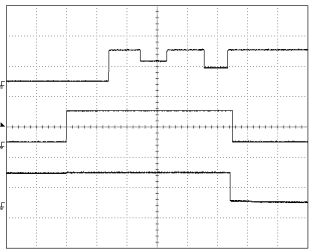
<p>⑧ CH1:FIN 500mV/div. 200ms/div. ⑪ CH2:FE 500mV/div.</p> <p><b>Focus Search</b></p>  <p>Ref. : REFO Mode : TEST</p>	<p>⑩ CH1:TE 500mV/div. 2ms/div. ⑬ CH2:RFAGC 500mV/div.</p> <p><b>When "Tracking Open"</b></p>  <p>Ref. : REFO Mode : TEST</p>	<p>⑬ CH1:RFAGC 1V/div. ⑩ CH2:TE 500mV/div. 500µs/div. ⑦ CH3:TIN 500mV/div.</p> <p><b>1Track Jump</b></p>  <p>Ref. : REFO Mode : TEST</p>
<p>⑬ CH1:RFAGC 1V/div. ⑩ CH2:TE 500mV/div. 1ms/div. ⑦ CH3:TIN 500mV/div.</p> <p><b>32Track Jump</b></p>  <p>Ref. : REFO Mode : TEST</p>	<p>⑬ CH1:RFAGC 1V/div. ⑩ CH2:TE 500mV/div. 5ms/div. ⑦ CH3:TIN 500mV/div.</p> <p><b>100Track Jump</b></p>  <p>Ref. : REFO Mode : TEST</p>	<p>⑬ CH1:RFAGC 1V/div. ⑦ CH2:TIN 1V/div. 500µs/div. ⑩ CH3:TE 1V/div. ⑧ CH4:FIN 1V/div.</p> <p><b>When reproducing black dots(800µm)</b></p>  <p>Ref. : REFO Mode : Normal</p>
<p>⑬ CH1:RFAGC 1V/div. ⑩ CH2:TE 1V/div. 500µs/div. ⑥ CH3:CIN 500mV/div. ⑤ CH4:SIN 2V/div.</p> <p><b>During inside/outside search (outer circumference → inner circumference)</b></p>  <p>Ref. : REFO Mode : Normal</p>	<p>⑭ CH1:LRCKIN 2V/div. ⑮ CH2:DIN 2V/div. 10µs/div. ⑯ CH3:SCKIN 2V/div.</p> <p><b>Digital Audio</b></p>  <p>Ref. : GND Mode : Normal</p>	<p>⑭ CH1:LRCKIN 2V/div. ⑮ CH2:DIN 2V/div. 2µs/div. ⑯ CH3:SCKIN 2V/div.</p> <p><b>Digital Audio (Magnified)</b></p>  <p>Ref. : REFO Mode : Normal</p>
<p>⑰ CH1:LOUT 1V/div. 200µs/div. ⑱ CH2:ROUT 1V/div.</p> <p><b>Analog Audio (Magnified)</b></p>  <p>Ref. : AGND Mode : Normal</p>	<p>① CH1:DSCSNS 5V/div. ② CH2:CLCONT 5V/div. 10µs/div. ③ CH3:LOEJ 5V/div.</p> <p><b>When "Eject" (12cm CD)</b></p>  <p>Ref. : GND Mode : Normal</p>	<p>① CH1:DSCSNS 5V/div. ② CH2:CLCONT 5V/div. 10µs/div. ③ CH3:LOEJ 5V/div.</p> <p><b>When "Eject" (8cm CD)</b></p>  <p>Ref. : GND Mode : Normal</p>

# 4. PCB CONNECTION DIAGRAM

## 4.1 TUNER AMP UNIT

### NOTE FOR PCB DIAGRAMS

1.The parts mounted on this PCB include all necessary parts for several destination.  
 For further information for respective destinations, be sure to check with the schematic diagram.

2.Viewpoint of PCB diagrams

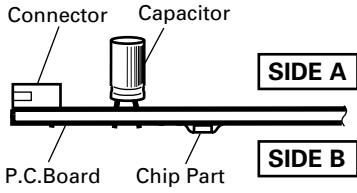

### **A** TUNER AMP UNIT

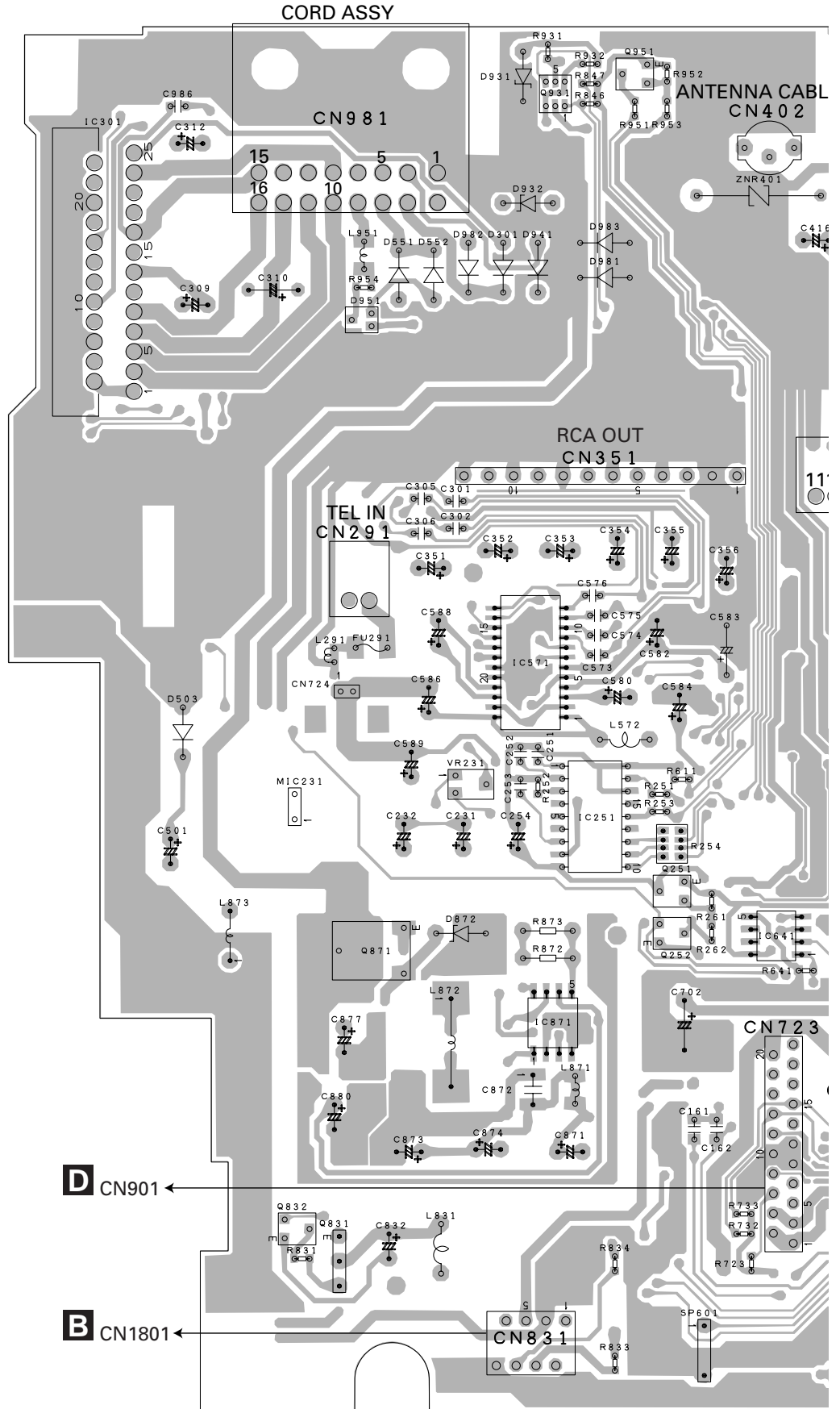



SIDE A

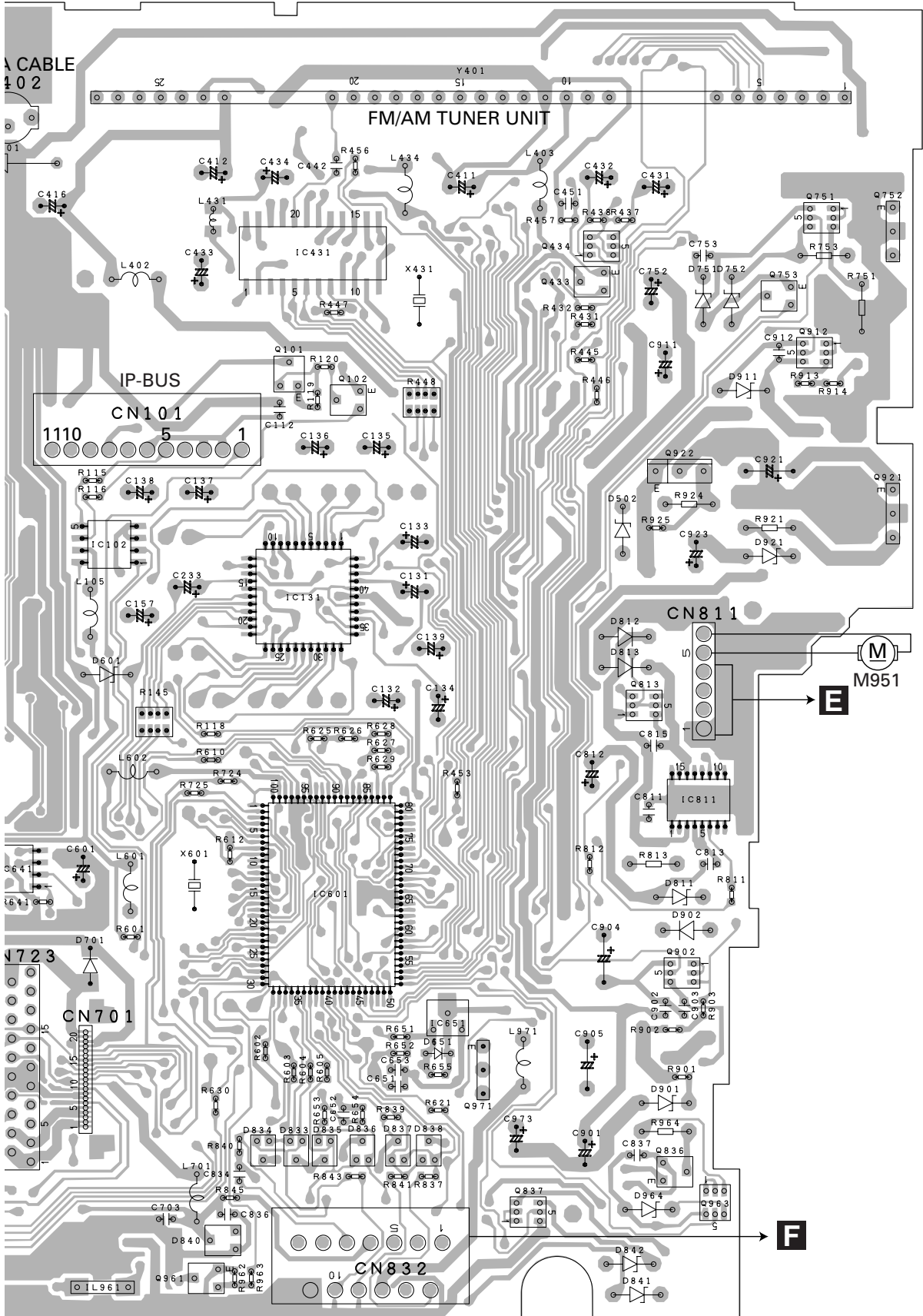

- IC, Q
- Q951
- Q931
- IC301
- Q752 Q751
- Q434
- IC431
- Q753 Q433
- Q912
- Q101 Q102
- Q922
- Q921
- IC102
- IC131
- IC571
- Q813
- IC251
- IC811 Q251
- Q252 IC641
- Q871
- IC601
- IC871 Q902
- IC651
- Q971
- Q832
- Q831 Q836
- Q837
- Q963
- Q961

FRONT

A

**A** TUNER AMP UNIT

A

IC,Q

- Q437
- Q401
- Q432
- Q941
- Q301 Q302 Q431 Q436
- IC551
- Q911
- Q923 Q353 Q352 Q351
- Q503
- Q501
- Q253
- Q811
- Q812
- Q872
- Q901
- Q651 Q972
- Q962
- Q834
- Q835
- Q833

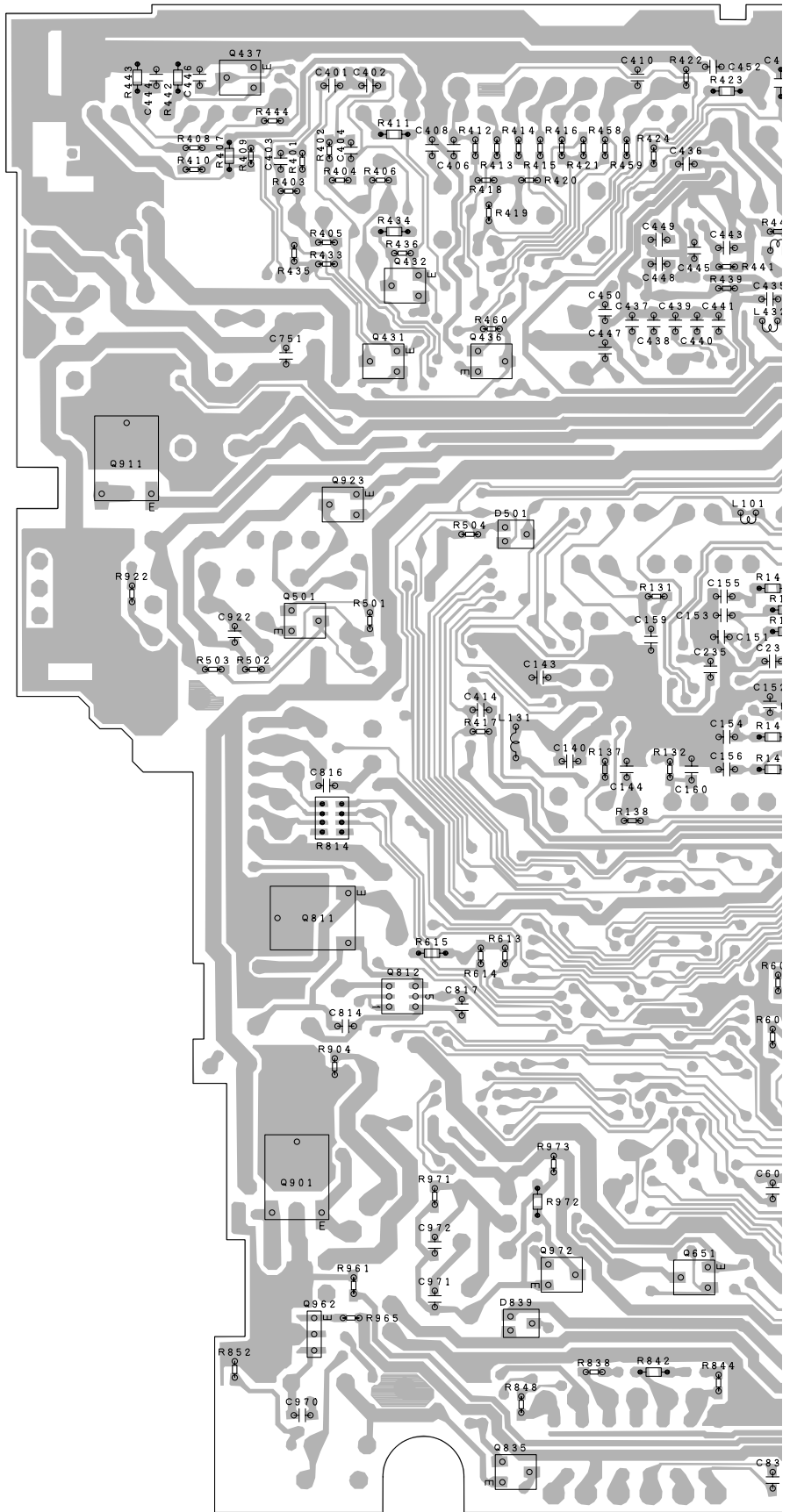

B

C

D

SIDE B

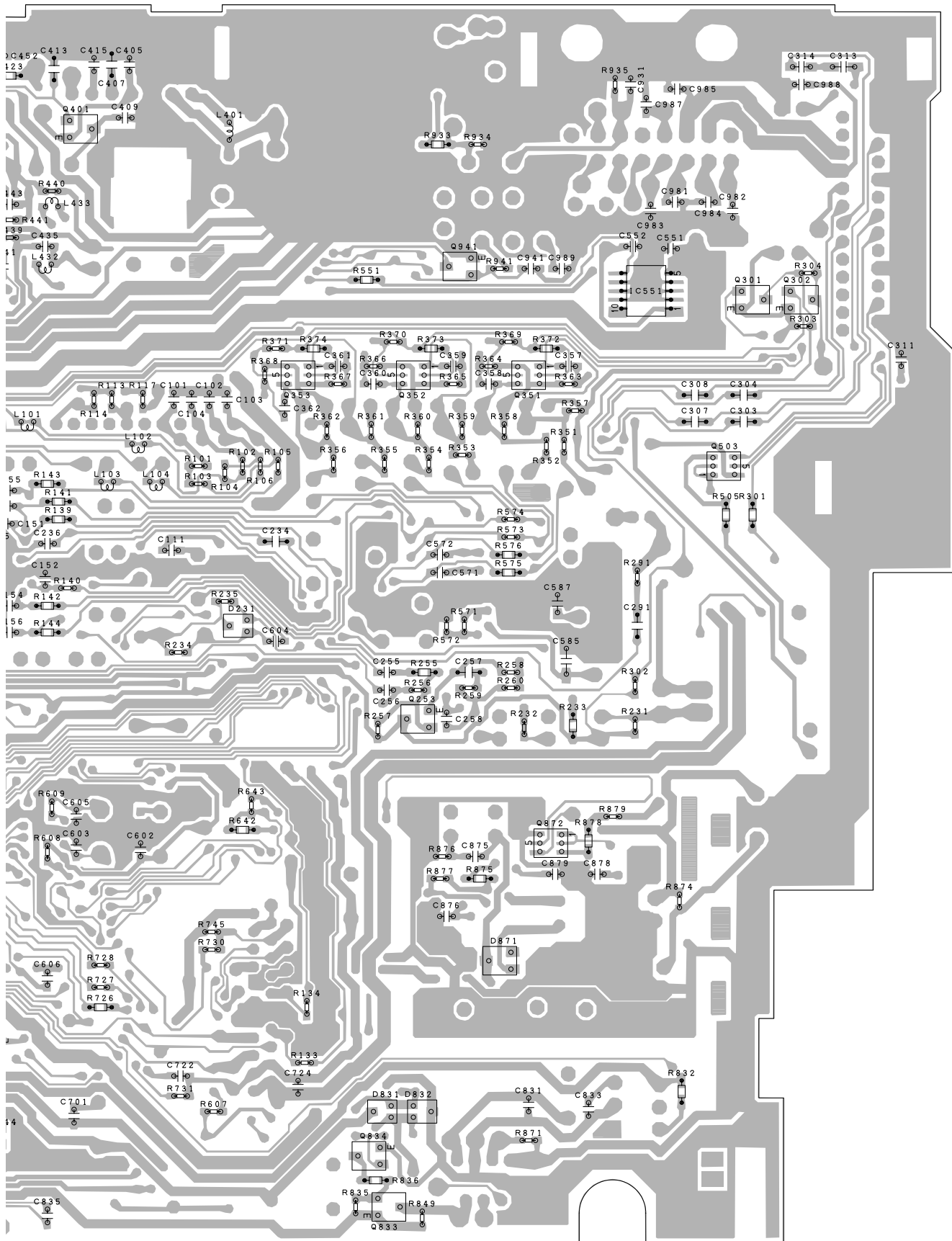

A

B

C

D

A

4.2 KEYBOARD UNIT(OEL)

**B** KEYBOARD UNIT(OEL) **SIDE A**

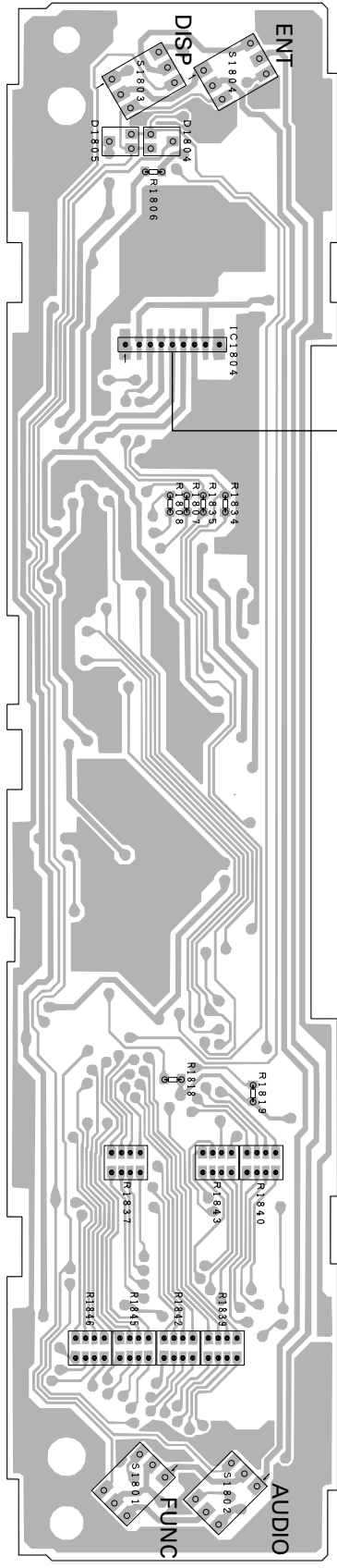

**B** KEYBOARD UNIT(OEL) **SIDE B**

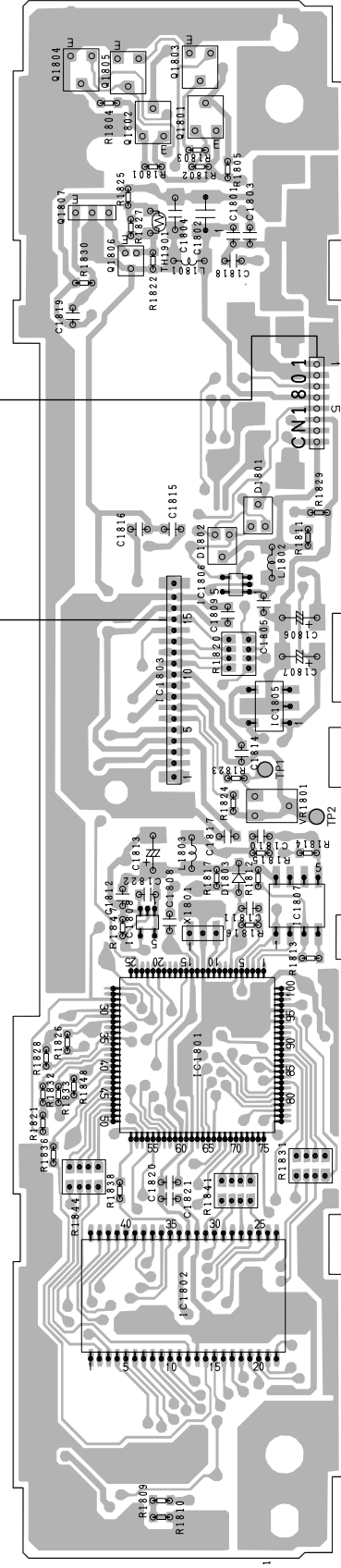

**A**  
CN831

→ OEL UNIT ←

- IC,Q ADJ
- Q1807
- Q1805
- Q1804
- Q1806
- Q1805
- Q1802
- IC1808
- IC1803
- Q1803
- Q1802
- IC1801
- IC1801
- IC1806
- IC1805
- IC1807
- IC1807
- IC1807

4.3 KEYBOARD UNIT(LCD)

**C** KEYBOARD UNIT(LCD) **SIDE A**

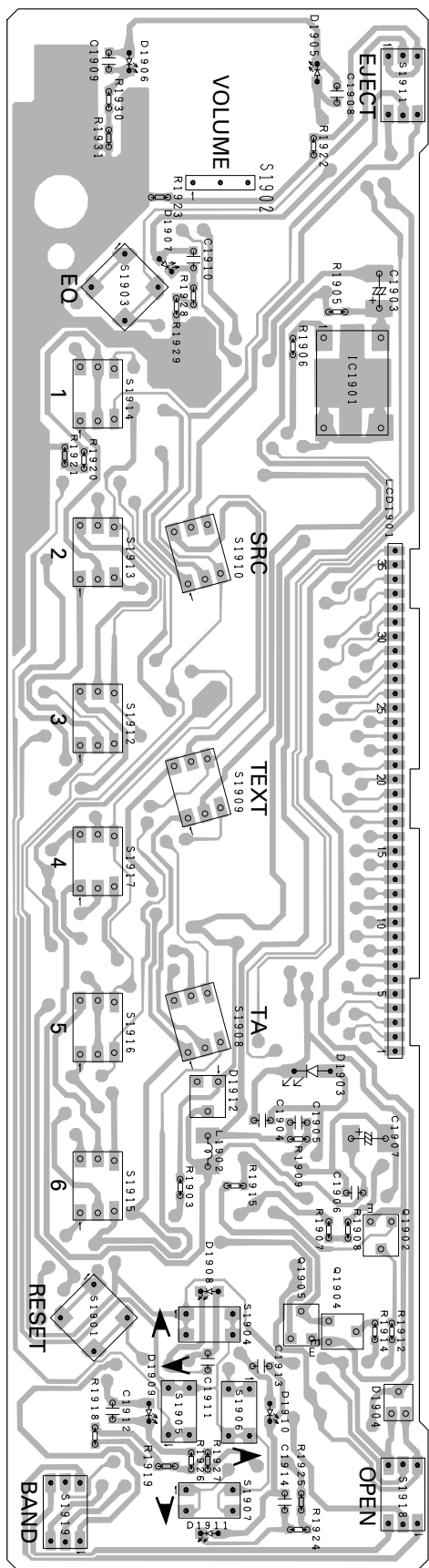

- IC0
- Q1902
- IC1901
- Q1904
- Q1905

**C** KEYBOARD UNIT(LCD) **SIDE B**

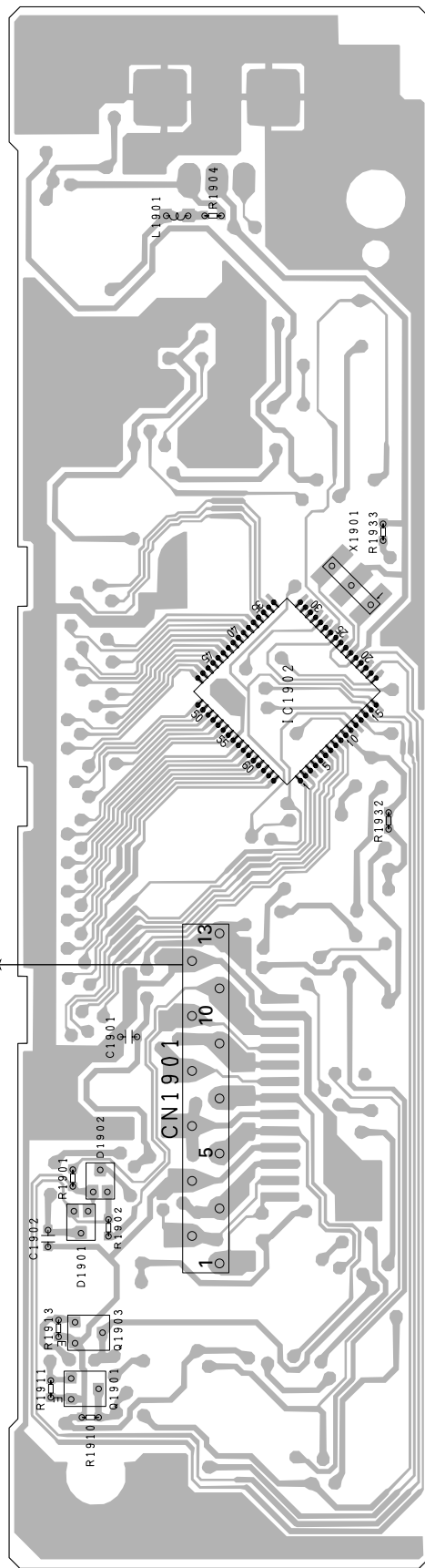

- IC0
- Q1903
- Q1901
- Q1902
- 200IC1

A  
B  
C  
D



4.4 CD MECHANISM MODULE

D CD CORE UNIT (S9MP3)

SIDE A

A

B

C

D

IC, Q

Q603

IC701

IC703

Q701

IC201

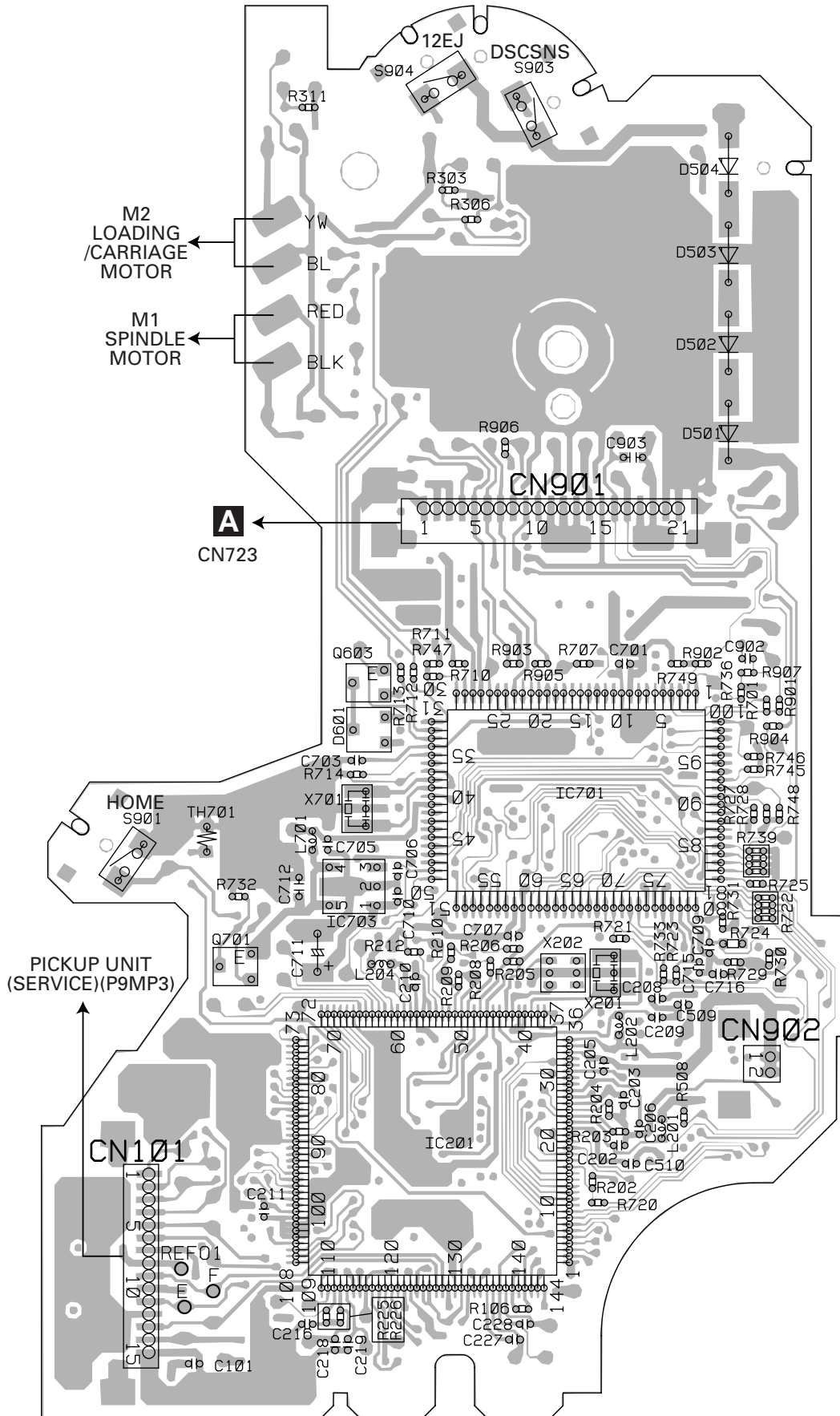



**D** CD CORE UNIT (S9MP3)

**SIDE B**

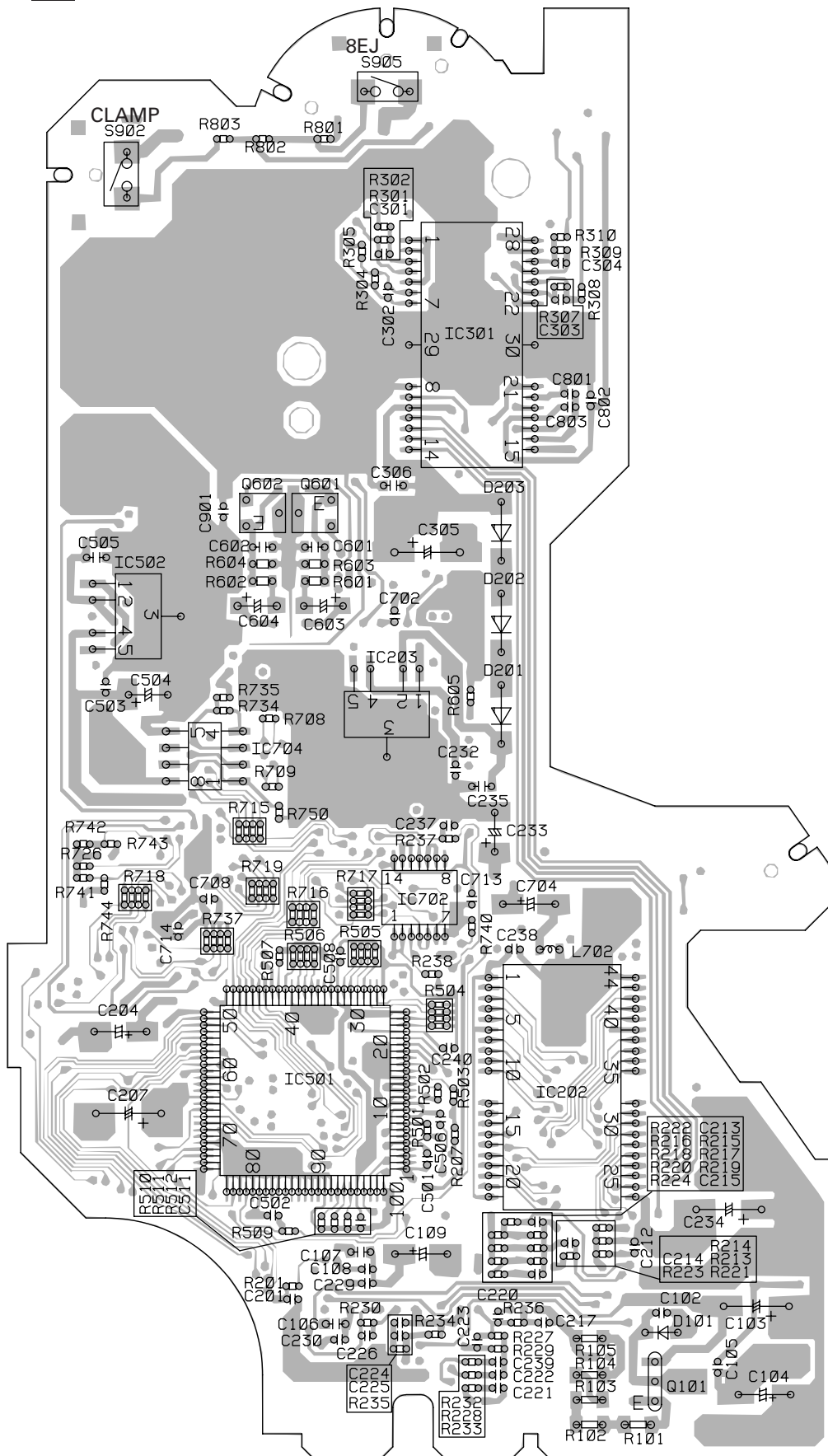

- IC, Q
- A
- IC301
- B
- Q602  
Q601
- IC502
- IC203
- IC704
- C
- IC702
- IC501  
IC202
- D
- Q101

### 4.5 SWITCH PCB

**E** SWITCH PCB

**SIDE A**

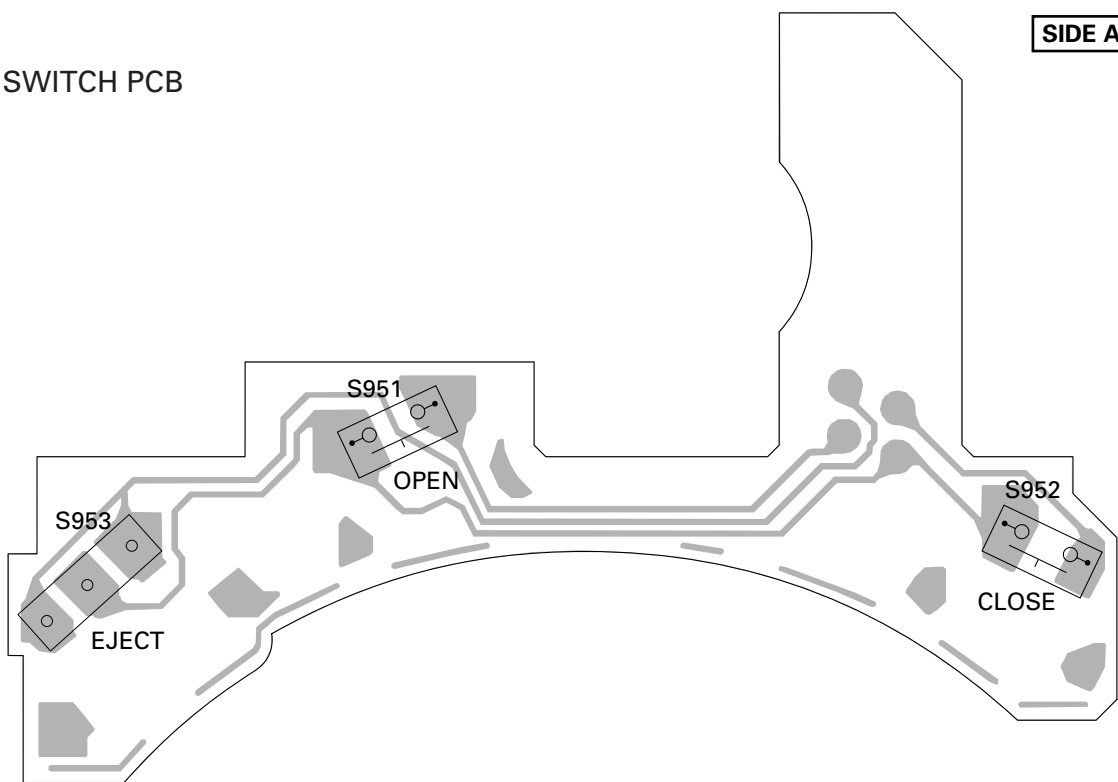

**E** SWITCH PCB

**SIDE B**

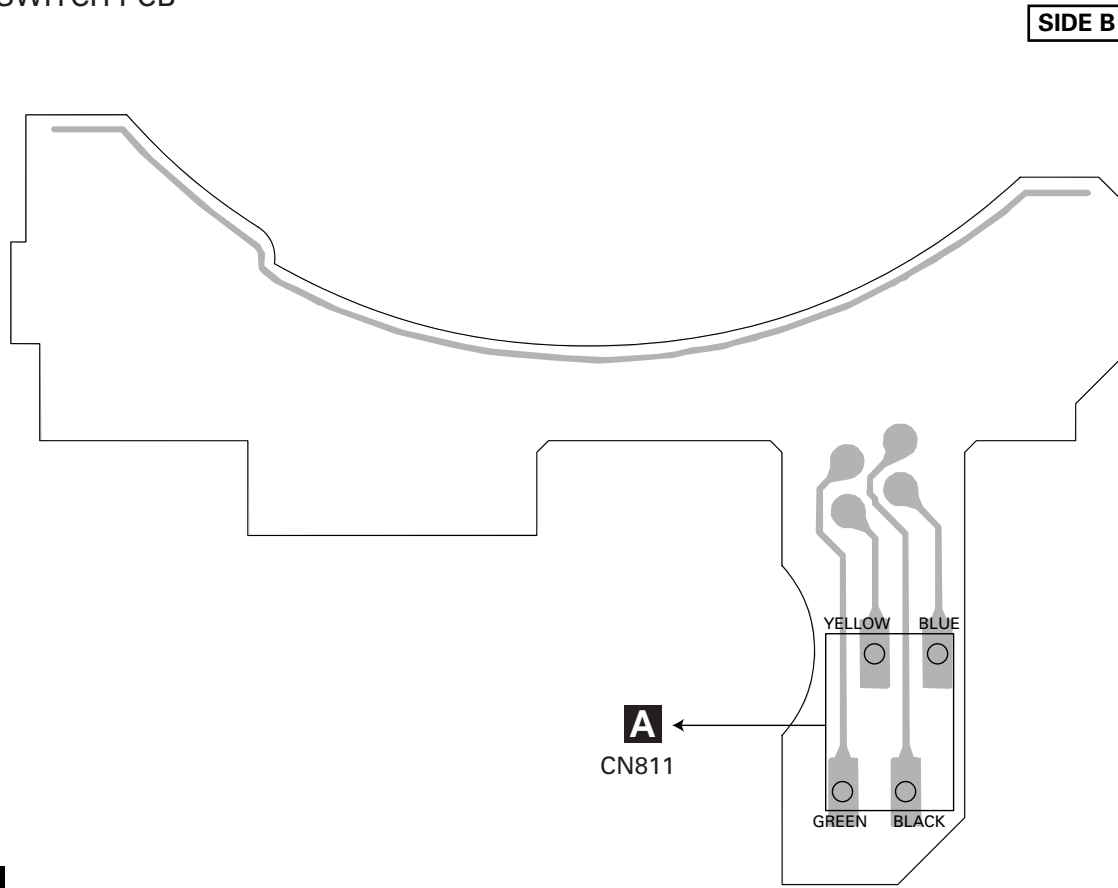



### 4.6 CONNECTOR PCB

**F** CONNECTOR PCB **SIDE A**

**F** CONNECTOR PCB **SIDE B**

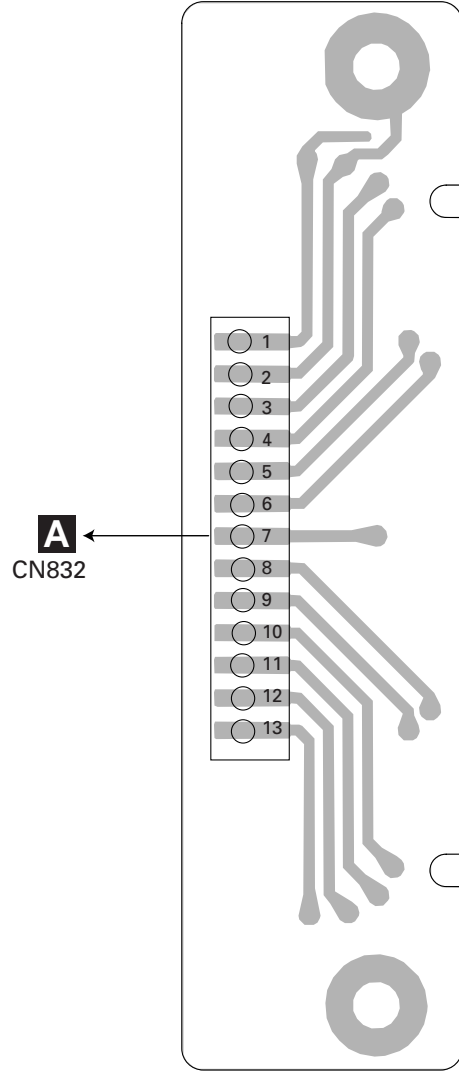
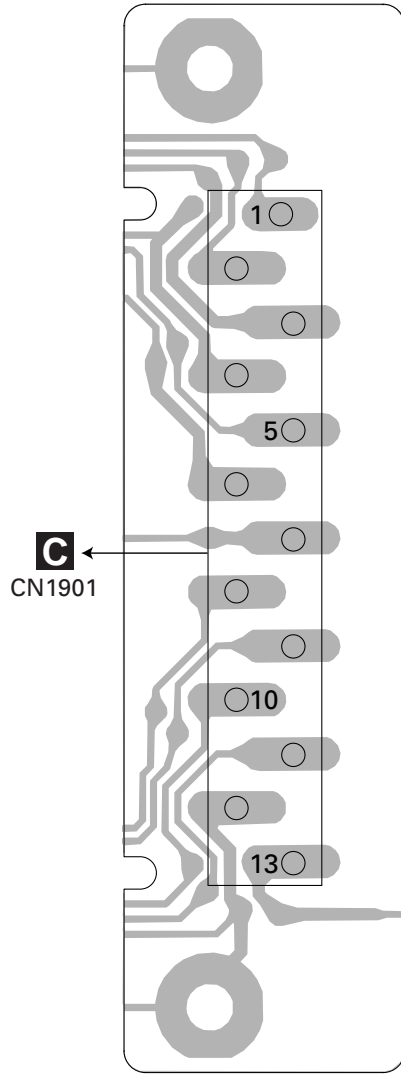

## 5. ELECTRICAL PARTS LIST

**NOTES:**

- Parts whose parts numbers are omitted are subject to being not supplied.
- The part numbers shown below indicate chip components.

Chip Resistor

RS1/OSOOOJ,RS1/OOSOOOJ

Chip Capacitor (except for CQS.....)

CKS....., CCS....., CSZS.....

====Circuit Symbol and No.====Part Name	Part No.	====Circuit Symbol and No.====Part Name	Part No.
<b>A</b> Unit Number : CWM8041		Q 961 Transistor	2SC2412K
Unit Name : Tuner Amp Unit		Q 962 Transistor	2SD1767
MISCELLANEOUS		Q 963 Transistor	IMD2A
IC 102 IC	HA12187FP	Q 971 Transistor	2SB808
IC 131 IC	PML009A	Q 972 Transistor	DTC114EK
IC 251 IC	BA3834F	D 231 Diode	RB706F-40
IC 301 IC	PAL007A	D 301 Diode	1SR139-400
IC 431 IC	PM4009A	D 501 Diode	DAN202U
		D 502 Diode	HZS9L(A2)
		D 503 Diode	1SS133
IC 571 IC	PA2028A	D 751 Diode	HZS9L(B1)
IC 601 IC	PD5740A	D 811 Diode	HZS7L(B2)
IC 651 IC	S-80735ANDZI	D 812 Diode	1SS133
IC 811 IC	BA6288FS	D 813 Diode	1SS133
IC 871 IC	NJM2360M	D 833 Diode	DAN202U
Q 101 Transistor	2SA1037K	D 834 Diode	DAP202U
Q 102 Transistor	DTC124EK	D 835 Diode	DAN202U
Q 251 Transistor	2SA1037K	D 836 Diode	DAP202U
Q 252 Transistor	DTC144EK	D 837 Diode	DAN202U
Q 253 Transistor	2SC2412K	D 838 Diode	DAP202U
Q 301 Transistor	DTC124EK	D 839 Diode Network	DA204U
Q 351 Transistor	IMH3A	D 841 Diode	HZS6L(A2)
Q 352 Transistor	IMH3A	D 842 Diode	HZS9L(A1)
Q 353 Transistor	IMH3A	D 871 Diode	RB411D
Q 401 Transistor	2SC2412K	D 872 Diode	HZS11L(A1)
Q 431 Transistor	2SD1757K	D 901 Diode	HZS6L(B1)
Q 432 Transistor	2SD1757K	D 902 Diode	1SR139-400
Q 433 Transistor	2SC2412K	D 911 Diode	HZS6L(B2)
Q 434 Transistor	IMH3A	D 921 Diode	HZS9L(B3)
Q 436 Transistor	DTA124EK	D 931 Diode	HZS7L(C3)
Q 437 Transistor	2SC2412K	D 932 Diode	HZS7L(A1)
Q 501 Transistor	2SC2412K	D 941 Diode	1SR139-400
Q 503 Transistor	IMD2A	D 951 Diode	DAN202U
Q 651 Transistor	2SC2412K	D 964 Diode	HZS11L(A1)
Q 751 Transistor	IMD2A	D 981 Diode	1SR139-400
Q 752 Transistor	2SD2396	D 982 Diode	1SR139-400
Q 811 Transistor	2SD1760F5	D 983 Diode	1SR139-400
Q 812 Transistor	IMD3A	ZNR 401 Surge Protector	DSP-201M-A21F
Q 831 Transistor	2SB808	L 105 Ferri-Inductor	LAU2R2K
Q 832 Transistor	DTC114EK	L 401 Inductor	LCTB4R7K2125
Q 835 Transistor	DTC114EK	L 402 Inductor	LAU1R0K
Q 836 Transistor	2SC2412K	L 403 Inductor	LAU100K
Q 837 Transistor	IMD2A	L 431 Inductor	CTF1529
Q 871 Transistor	2SD1760F5	L 432 Inductor	CTF1378
Q 872 Transistor	IMD2A	L 433 Inductor	CTF1378
Q 901 Transistor	2SD1760F5	L 434 Ferri-Inductor	LAU2R2K
Q 902 Transistor	IMD2A	L 572 Ferri-Inductor	LAU101K
Q 911 Transistor	2SD1760F5	L 601 Inductor	LAU100K
Q 912 Transistor	IMD2A	L 701 Inductor	LAU100K
Q 921 Transistor	2SD2396	L 831 Inductor	LAU100K
Q 922 Transistor	2SB1238	L 872 Inductor	CTF1510
Q 923 Transistor	DTC114EK	L 951 Inductor	CTF1530
Q 931 Transistor	IMX1	L 971 Inductor	LAU100K
Q 941 Transistor	DTC114EK	X 431 Crystal Resonator 3.648MHz	CSS1447
Q 951 Transistor	2SA1037K	X 601 Radiator 10.00MHz	CSS1475

====Circuit Symbol and No.====Part Name	Part No.	====Circuit Symbol and No.====Part Name	Part No.
IL 961 Lamp 14V 40mA	CEL1593	R 365	RS1/16S471J
VR 231 Semi-fixed 10kΩ(B)	CCP1229	R 366	RS1/16S471J
FU 291 Fuse 200mA	CEK1189	R 367	RS1/16S471J
MIC 231 Microphone	CPM1011	R 368	RS1/16S471J
SP 601 Buzzer	CPV1050	R 369	RS1/16S0R0J
FM/AM Tuner Unit	CWE1562	R 370	RS1/16S0R0J
		R 371	RS1/16S0R0J
		R 372	RS1/16S0R0J
		R 373	RS1/16S0R0J
		R 374	RS1/16S0R0J
<b>RESISTORS</b>			
R 101	RS1/16S181J		
R 102	RS1/16S181J		
R 103	RS1/16S223J	R 401	RS1/16S162J
R 104	RS1/16S223J	R 402	RS1/16S162J
R 105	RS1/16S102J	R 403	RS1/16S272J
		R 404	RS1/16S272J
R 106	RS1/16S102J	R 407	RS1/16S473J
R 113	RS1/16S150J		
R 114	RS1/16S470J	R 408	RS1/16S473J
R 115	RS1/16S101J	R 409	RS1/16S681J
R 116	RS1/16S101J	R 410	RS1/16S681J
		R 411	RS1/16S102J
		R 412	RS1/16S681J
R 117	RS1/16S222J		
R 118	RS1/16S103J		
R 119	RS1/16S332J	R 413	RS1/16S103J
R 120	RS1/16S562J	R 414	RS1/16S681J
R 131	RS1/16S102J	R 415	RS1/16S681J
		R 416	RS1/16S681J
		R 417	RS1/16S393J
R 132	RS1/16S102J		
R 133	RS1/16S102J		
R 134	RS1/16S102J	R 418	RS1/16S473J
R 139	RS1/16S101J	R 419	RS1/16S472J
R 140	RS1/16S101J	R 420	RS1/16S473J
		R 421	RS1/16S473J
		R 422	RS1/16S473J
R 141	RS1/16S101J		
R 142	RS1/16S101J		
R 143	RS1/16S101J	R 423	RS1/16S222J
R 144	RS1/16S101J	R 424	RS1/16S222J
R 145	RAB4C102J	R 431	RS1/16S224J
		R 432	RS1/16S224J
		R 433	RS1/16S222J
R 231	RS1/16S222J		
R 233	RS1/16S560J		
R 234	RS1/16S104J	R 434	RS1/16S222J
R 235	RS1/16S104J	R 435	RS1/16S223J
R 251	RS1/16S102J	R 436	RS1/16S223J
		R 437	RS1/16S104J
		R 438	RS1/16S104J
R 252	RS1/16S104J		
R 253	RS1/16S473J		
R 254	RAB4C102J	R 441	RS1/16S225J
R 255	RS1/16S224J	R 442	RS1/16S153J
R 256	RS1/16S224J	R 443	RS1/16S473J
		R 444	RS1/16S681J
		R 445	RS1/16S474J
R 257	RS1/16S104J		
R 258	RS1/16S102J		
R 259	RS1/16S103J	R 446	RS1/16S681J
R 260	RS1/16S103J	R 447	RS1/16S681J
R 261	RS1/16S223J	R 448	RAB4C102J
		R 453	RS1/16S0R0J
		R 456	RS1/16S102J
R 262	RS1/16S822J		
R 291	RS1/16S102J		
R 301	RS1/16S103J	R 457	RS1/16S224J
R 302	RS1/16S103J	R 458	RS1/16S681J
R 303	RS1/16S103J	R 459	RS1/16S681J
		R 460	RS1/16S473J
		R 501	RS1/16S103J
R 304	RS1/16S331J		
R 351	RS1/16S820J		
R 352	RS1/16S820J	R 502	RS1/16S473J
R 353	RS1/16S820J	R 503	RS1/16S223J
R 354	RS1/16S820J	R 504	RS1/16S223J
		R 505	RS1/16S102J
		R 571	RS1/16S103J
R 355	RS1/16S820J		
R 356	RS1/16S820J		
R 357	RS1/16S223J	R 572	RS1/16S103J
R 358	RS1/16S223J	R 601	RS1/16S472J
R 359	RS1/16S223J	R 607	RS1/16S682J
		R 608	RS1/16S102J
		R 609	RS1/16S0R0J
R 360	RS1/16S223J		
R 361	RS1/16S223J		
R 362	RS1/16S223J		
R 363	RS1/16S471J		
R 364	RS1/16S471J		

====Circuit Symbol and No.====Part Name	Part No.	====Circuit Symbol and No.====Part Name	Part No.
R 611	RS1/16S104J	R 922	RS1/16S122J
R 612	RS1/16SOR0J	R 924	RD1/4PU272J
R 613	RS1/16S104J	R 925	RS1/16S223J
R 614	RS1/16S104J	R 931	RS1/16S104J
R 615	RS1/16S104J	R 932	RS1/16S473J
R 621	RS1/16SOR0J	R 933	RS1/16S103J
R 625	RS1/16S473J	R 934	RS1/16S473J
R 626	RS1/16S104J	R 935	RS1/16S472J
R 627	RS1/16S104J	R 941	RS1/16S103J
R 629	RS1/16S104J	R 951	RS1/16S102J
R 630	RS1/16S102J	R 952	RS1/16S472J
R 651	RS1/16S102J	R 953	RS1/16S472J
R 652	RS1/16S102J	R 954	RS1/16S153J
R 653	RS1/16S222J	R 961	RS1/16S1R0J
R 654	RS1/16S473J	R 962	RS1/16S103J
R 655	RS1/16S183J	R 963	RS1/16S682J
R 723	RS1/16S682J	R 964	RD1/4PU391J
R 724	RS1/16S221J	R 965	RS1/16S1R0J
R 725	RS1/16S221J	R 971	RS1/16S472J
R 726	RS1/16S221J	R 972	RS1/16S102J
R 727	RS1/16S221J	R 973	RS1/16S472J
R 728	RS1/16S221J	CAPACITORS	
R 730	RS1/16S221J		
R 731	RS1/16S473J	C 112	CKSRYB104K16
R 732	RS1/16S682J	C 131	CEAL1R0M50
R 733	RS1/16S682J	C 132	CEAL1R0M50
R 751	RD1/4PU271J	C 133	CEALR22M50
R 753	RD1/4PU221J	C 134	CEALR22M50
R 811	RS1/16S102J	C 135	CEAL1R0M50
R 812	RS1/16S102J	C 136	CEAL1R0M50
R 813	RD1/4PU391J	C 137	CEAL1R0M50
R 814	RAB4C102J	C 138	CEAL1R0M50
R 831	RS1/16S102J	C 139	CEJQ470M10
R 832	RS1/16S472J	C 140	CKSRYB104K16
R 833	RS1/16S222J	C 141	CEALNP4R7M16
R 834	RS1/16S222J	C 142	CEALNP4R7M16
R 837	RS1/16S222J	C 145	CEALNP4R7M16
R 838	RS1/16S222J	C 146	CEALNP4R7M16
R 839	RS1/16S473J	C 147	CEALNP4R7M16
R 840	RS1/16S104J	C 148	CEALNP4R7M16
R 841	RS1/16S222J	C 149	CEALNP4R7M16
R 842	RS1/16S222J	C 150	CEALNP4R7M16
R 843	RS1/16S222J	C 157	CEAL100M16
R 844	RS1/16S222J	C 159	CCSQCH152J50
R 845	RS1/16S103J	C 160	CCSQCH152J50
R 846	RS1/16S104J	C 161	CCSQCH152J50
R 847	RS1/16S104J	C 162	CCSQCH152J50
R 848	RS1/16S222J	C 231	CEJQ100M16
R 849	RS1/16SOR0J	C 232	CEJQ220M25
R 852	RS1/16S332J	C 233	CEAL100M16
R 872	RD1/4PU302J	C 234	CKSRYB474K10
R 873	RD1/4PU302J	C 235	CKSRYB474K10
R 874	RS1/16SOR0J	C 251	CKSRYB104K16
R 875	RS1/16S391J	C 252	CKSRYB104K16
R 876	RS1/16S121J	C 253	CKSRYB103K50
R 877	RS1/16S1R0J	C 254	CEJQ1R0M50
R 878	RS1/16S331J	C 255	CKSRYB104K16
R 879	RS1/16S331J	C 256	CKSRYB104K16
R 901	RS1/16S223J	C 257	CKSRYB224K10
R 902	RS1/16S821J	C 258	CKSRYB104K16
R 903	RS1/16S821J	C 291	CKSRYB224K16
R 904	RS1/16SOR0J	C 301	CKSRYB474K10
R 913	RS1/16S681J	C 302	CKSRYB474K10
R 914	RS1/16S681J	C 303	CKSRYB474K10
R 921	RD1/4PU221J	C 304	CKSRYB474K10
		C 305	CKSRYB474K10
		C 306	CKSRYB474K10
		C 307	CKSRYB474K10

====Circuit Symbol and No.====Part Name	Part No.	====Circuit Symbol and No.====Part Name	Part No.
C 308	CKSRYP474K10	C 603	CCSRCH180J50
C 309	CEHAR330M10	C 604	CCSRCH101J50
C 310	CCH1433	C 605	CCSRCH220J50
C 311	CKSRYP104K16	C 652	CKSRYP104K16
C 312	CEHAR100M16	C 653	CKSRYP105K10
C 313	CKSQYB225K10	C 702	470µF/16V
C 314	CKSQYB225K10	C 751	
C 351	CEAL100M16	C 752	
C 352	CEAL100M16	C 753	
C 353	CEAL100M16	C 811	
C 354	CEAL100M16	C 812	
C 355	CEAL100M16	C 813	
C 356	CEAL100M16	C 814	
C 357	CKSRYP222K50	C 815	
C 358	CKSRYP222K50	C 816	
C 359	CKSRYP222K50	C 833	
C 360	CKSRYP222K50	C 837	
C 361	CKSRYP222K50	C 872	4.7µF
C 362	CKSRYP222K50	C 873	
C 401	CKSRYP103K50	C 874	
C 402	CKSRYP103K50	C 875	
C 403	CKSRYP222K50	C 876	
C 404	CKSRYP222K50	C 877	
C 408	CKSRYP473K50	C 878	
C 409	CKSRYP103K50	C 879	
C 410	CCSRCH101J50	C 880	
C 411	CEJQ101M10	C 901	
C 413	CKSRYP223K50	C 902	
C 414	CKSRYP472K50	C 903	
C 415	CKSRYP223K50	C 904	470µF/16V
C 416	CEJQ220M10	C 905	470µF/16V
C 431	CEJQ1R0M50	C 911	
C 432	CEJQ1R0M50	C 912	
C 433	CEJQ220M6R3	C 921	
C 434	CEJQ220M6R3	C 922	
C 435	CKSRYP473K50	C 923	
C 436	CKSRYP473K50	C 931	
C 437	CCSRCH101J50	C 941	
C 442	CCSRCH471J50	C 970	
C 443	CCSRCH471J50	C 972	
C 444	CKSRYP182K50	<b>B</b> Unit Number : CWM8050	
C 445	CKSRYP104K16	Unit Name : Keyboard Unit(OEL)	
C 446	CKSRYP472K50	<b>MISCELLANEOUS</b>	
C 447	CCSRCH270J50	IC 1801	IC
C 448	CCSRCH101J50	IC 1802	IC
C 449	CKSRYP473K50	IC 1805	IC
C 450	CCSRCH270J50	IC 1806	IC
C 451	CKSRYP223K50	Q 1801	Transistor
C 501	CEJQ220M16	Q 1802	Transistor
C 571	CKSRYP105K10	Q 1803	Transistor
C 572	CKSRYP105K10	Q 1804	Transistor
C 573	CKSRYP105K10	Q 1805	Transistor
C 574	CKSRYP105K10	Q 1806	Transistor
C 575	CKSRYP105K10	Q 1807	Transistor
C 576	CKSRYP105K10	D 1803	Diode
C 580	CEAL4R7M35	D 1804	Diode
C 582	CEJQ101M16	D 1805	Diode
C 583	CASAQ3R3M16	L 1801	Inductor
C 585	CKSYB684K25	L 1803	Inductor
C 586	CEAL100M16	TH 1901	Thermistor
C 587	CKSQYB225K10	X 1801	Radiator 10.0MHz
C 588	CEJQ330M25	S 1801	Push Switch
C 589	CEJQ330M25	S 1802	Push Switch
C 601	CEAL4R7M35	S 1803	Push Switch
C 602	CKSRYP103K50	S 1804	Push Switch
		VR 1801	Semi-fixed 15kΩ(B) OEL Unit

====Circuit Symbol and No.====Part Name Part No.

RESISTORS

R 1801	RS1/16S473J
R 1802	RS1/16S473J
R 1803	RS1/16S183J
R 1804	RS1/16S183J
R 1806	RS1/16S472J
R 1807	RS1/16S222J
R 1808	RS1/16S222J
R 1809	RS1/16S820J
R 1815	RS1/16S222J
R 1816	RS1/16S0R0J
R 1817	RS1/16S154J
R 1818	RS1/16S473J
R 1819	RS1/16S473J
R 1820	RAB4C102J
R 1821	RS1/16S473J
R 1822	RS1/16S333J
R 1823	RS1/16S222J
R 1824	RS1/16S682J
R 1825	RS1/16S393J
R 1826	RS1/16S0R0J
R 1827	RS1/16S683J
R 1828	RS1/16S0R0J
R 1830	RS1/16S392J
R 1831	RAB4C101J
R 1832	RS1/16S473J
R 1833	RS1/16S473J
R 1834	RS1/16S102J
R 1835	RS1/16S102J
R 1836	RS1/16S101J
R 1837	RAB4C101J
R 1838	RS1/16S101J
R 1839	RAB4C101J
R 1840	RAB4C101J
R 1841	RAB4C101J
R 1842	RAB4C101J
R 1843	RAB4C101J
R 1844	RAB4C101J
R 1845	RAB4C101J
R 1846	RAB4C101J
R 1847	RS1/16S682J
R 1848	RS1/16S473J

CAPACITORS

C 1803	CCSRCH101J50
C 1805	CKSRYB102K50
C 1806	CSZSR4R7M10
C 1807	CSZSR4R7M10
C 1808	CKSRYB103K50
C 1809	CKSRYB104K25
C 1811	CKSRYB473K50
C 1812	CKSRYB103K50
C 1813	CSZSR4R7M10
C 1814	CKSRYB104K16
C 1815	CKSRYB104K25
C 1816	CKSRYB104K25
C 1817	CKSRYB104K25
C 1819	CKSRYB104K16
C 1820	CKSRYB103K50
C 1821	CKSRYB103K50

====Circuit Symbol and No.====Part Name Part No.

 Unit Number : CWM8055  
Unit Name : Keyboard Unit(LCD)

MISCELLANEOUS

IC 1901	IC	RS-140
IC 1902	IC	PD6340A
Q 1901	Transistor	2SB710A
Q 1902	Transistor	DTC114EK
Q 1903	Transistor	2SB710A
Q 1904	Transistor	DTC114EK
Q 1905	Transistor	DTC114EK
D 1903	LED	NSSW440-9159
D 1905	LED	CL190UBX
D 1906	LED	CL190UBX
D 1907	LED	CL190UBX
D 1908	LED	CL190UBX
D 1909	LED	CL190UBX
D 1910	LED	CL190UBX
D 1911	LED	CL190UBX
L 1902	Inductor	CTF1530
X 1901	Ceramic Resonator 4.97MHz	CSS1422
S 1901	Switch	CSG1110
S 1902	Encoder	CSD1042
S 1903	Switch	CSG1110
S 1904	Push Switch	CSG1111
S 1905	Push Switch	CSG1111
S 1906	Push Switch	CSG1111
S 1907	Push Switch	CSG1111
S 1908	Push Switch	CSG1115
S 1909	Push Switch	CSG1115
S 1910	Push Switch	CSG1115
S 1911	Push Switch	CSG1113
S 1912	Push Switch	CSG1115
S 1913	Push Switch	CSG1115
S 1914	Push Switch	CSG1115
S 1915	Push Switch	CSG1115
S 1916	Push Switch	CSG1115
S 1917	Push Switch	CSG1115
S 1918	Push Switch	CSG1113
S 1919	Push Switch	CSG1113
LCD1901	LCD	CAW1704

RESISTORS

R 1901	RS1/16S222J
R 1902	RS1/16S222J
R 1903	RS1/16S104J
R 1904	RS1/16S103J
R 1905	RS1/16S121J
R 1906	RS1/16S2R2J
R 1907	RS1/16S101J
R 1908	RS1/16S101J
R 1911	RS1/16S473J
R 1912	RS1/16S272J
R 1913	RS1/16S473J
R 1914	RS1/16S272J
R 1915	RS1/16S472J
R 1918	RS1/16S560J
R 1920	RS1/16S560J
R 1922	RS1/16S560J
R 1924	RS1/16S271J
R 1926	RS1/16S271J
R 1928	RS1/16S331J
R 1929	RS1/16S331J
R 1930	RS1/16S271J

====Circuit Symbol and No.====Part Name	Part No.	====Circuit Symbol and No.====Part Name	Part No.
<b>CAPACITORS</b>		<b>RESISTORS</b>	
C 1901	CKSRYP104K25	R 101	RS1/10S1R5J
C 1903	CSZSR4R7M10	R 102	RS1/10S1R5J
C 1904	CKSRYP104K16	R 103	RS1/10S1R5J
C 1905	CCSRCH101J50	R 104	RS1/10S1R5J
C 1908	CKSRYP104K16	R 105	RS1/10S1R5J
C 1909	CKSRYP104K16	R 201	RS1/16SS102J
C 1910	CKSRYP104K16	R 202	RS1/16SS333J
C 1911	CKSRYP104K16	R 203	RS1/16SS333J
C 1912	CKSRYP104K16	R 204	RS1/16SS333J
C 1913	CKSRYP104K16	R 206	RS1/16SS0R0J
C 1914	CKSRYP104K16	R 208	RS1/16SS0R0J
<b>E</b> Unit Number : Unit Name : Switch PCB		R 210	RS1/16SS0R0J
		R 212	RS1/16SS221J
<b>MISCELLANEOUS</b>		R 213	RS1/16SS1002D
		R 214	RS1/16SS1002D
S 951	Switch(OPEN) CSN1051	R 215	RS1/16SS1002D
S 952	Spring Switch(CLOSE) CSN1052	R 216	RS1/16SS1002D
S 953	Switch(EJECT) CSN1058	R 217	RS1/16SS1002D
<b>D</b> Unit Number : CWX2618 Unit Name : CD Core Unit(S9MP3)		R 218	RS1/16SS1002D
		R 219	RS1/16SS1002D
<b>MMISCELLANEOUS</b>		R 220	RS1/16SS1002D
		R 221	RS1/16SS103J
IC 201	IC UPD63760GJ	R 222	RS1/16SS103J
IC 202	IC MSM51V4265EP-70TS	R 223	RS1/16SS103J
IC 203	IC BA033SFP	R 224	RS1/16SS103J
IC 301	IC BA5996FM	R 225	RS1/16SS103J
IC 501	IC UPD61002GC	R 226	RS1/16SS393J
IC 502	IC BA25BC0WFP	R 227	RS1/16SS103J
IC 701	IC PE5269A	R 228	RS1/16SS182J
IC 702	IC TC74VHCT08AFT	R 229	RS1/16SS103J
IC 703	IC S-818A33AUC-BGN	R 233	RS1/16SS183J
IC 704	IC PD9023A	R 237	RS1/16SS104J
Q 101	Transistor 2SB1132	R 238	RS1/16SS473J
Q 601	Transistor DTC323TK	R 301	RS1/16SS183J
Q 602	Transistor DTC323TK	R 302	RS1/16SS822J
Q 603	Transistor 2SB709A	R 303	RS1/16SS0R0J
Q 701	Transistor UN2111	R 304	RS1/16SS183J
D 101	Diode 1SS355	R 305	RS1/16SS822J
D 201	Diode 1SR154-400	R 306	RS1/16SS0R0J
D 202	Diode 1SR154-400	R 307	RS1/16SS183J
D 203	Diode 1SR154-400	R 308	RS1/16SS822J
D 501	Diode 1SR154-400	R 309	RS1/16SS183J
D 502	Diode 1SR154-400	R 310	RS1/16SS822J
D 503	Diode 1SR154-400	R 311	RS1/16SS0R0J
D 504	Diode 1SR154-400	R 501	RS1/16SS221J
D 601	Chip Diode MA151WA	R 502	RS1/16SS221J
L 201	Inductor CTF1546	R 503	RAB4CQ223J
L 202	Inductor CTF1546	R 504	RAB4CQ223J
L 204	Inductor CTF1546	R 505	RAB4CQ223J
L 701	Inductor CTF1546	R 506	RAB4CQ223J
L 702	Inductor LCYBR22J1608	R 507	RS1/16SS223J
TH 701	Thermistor CCX1037	R 508	RS1/16SS223J
X 201	Ceramic Resonator 16.93MHz	R 509	RS1/16SS102J
X 202	Ceramic Resonator 24.57MHz	R 510	RS1/16SS223J
X 701	Ceramic Resonator 16.00MHz	R 511	RS1/16SS223J
S 901	Spring Switch (HOME) CSN1051	R 512	RS1/16SS223J
S 902	Spring Switch (CLAMP) CSN1052	R 601	RS1/16S101J
S 903	Spring Switch (DSCSNS) CSN1051	R 602	RS1/16S101J
S 904	Spring Switch (12EJ) CSN1052	R 603	RS1/16S223J
S 905	Spring Switch (8EJ) CSN1051	R 604	RS1/16S223J
S 903	Spring Switch (DSCSNS) CSN1051	R 605	RS1/16SS103J
S 904	Spring Switch (12EJ) CSN1052	R 701	RS1/16SS0R0J
S 905	Spring Switch (8EJ) CSN1051	R 707	RS1/16SS0R0J
		R 708	RS1/16SS102J
		R 709	RS1/16SS102J

# DEH-P8400MP

====Circuit Symbol and No.====Part Name	Part No.	====Circuit Symbol and No.====Part Name	Part No.
R 710	RS1/16SS102J	C 217	CKSSYB104K10
R 711	RS1/16SS102J	C 218	CKSSYB223K16
R 712	RS1/16SS102J	C 219	CKSSYB104K10
R 713	RS1/16SS102J	C 220	CKSSYB103K16
R 714	RS1/16SS473J	C 221	CKSSYB104K10
R 715	RAB4CQ221J	C 222	CCSSCH270J50
R 716	RAB4CQ221J	C 223	CCSSCJ3R0C50
R 717	RAB4CQ221J	C 224	CKSSYB104K10
R 718	RAB4CQ221J	C 225	CKSSYB103K16
R 719	RAB4CQ221J	C 226	CCSSCH680J50
R 720	RS1/16SS471J	C 227	CCSSCH470J50
R 721	RS1/16SS471J	C 228	CKSSYB682K25
R 722	RAB4CQ221J	C 230	CKSSYB104K10
R 723	RS1/16SS102J	C 232	CKSSYB104K10
R 724	RN1/16SE1302D	C 233	47µF/6.3V CCH1436
R 725	RS1/16SS222J	C 234	CEV221M4
R 726	RS1/16SS103J	C 235	CKSRYB224K16
R 727	RS1/16SS473J	C 237	CKSSYB104K10
R 728	RS1/16SS473J	C 238	CKSSYB104K10
R 729	RS1/16SS223J	C 240	CCSSCH100D50
R 730	RS1/16SS473J	C 301	CKSSYB331K50
R 731	RS1/16SS104J	C 302	CKSSYB331K50
R 732	RS1/16SS104J	C 303	CKSSYB472K25
R 733	RS1/16SS104J	C 304	CKSSYB472K25
R 734	RS1/16SS472J	C 305	CEV101M16
R 735	RS1/16SS473J	C 306	CKSRYB224K16
R 737	RAB4CQ473J	C 501	CKSSYB104K10
R 739	RAB4CQ473J	C 502	CKSSYB471K50
R 740	RS1/16SS473J	C 503	CKSSYB104K10
R 741	RS1/16SS104J	C 504	47µF/6.3V CCH1436
R 742	RS1/16SS104J	C 505	CKSRYB224K16
R 745	RS1/16SS473J	C 506	CKSSYB104K10
R 746	RS1/16SS104J	C 508	CKSSYB104K10
R 747	RS1/16SS104J	C 509	CKSSYB104K10
R 748	RS1/16SS104J	C 510	CKSSYB104K10
R 750	RS1/16SS473J	C 511	CKSSYB104K10
R 801	RS1/16SS104J	C 601	CCSRCH102J50
R 802	RS1/16SS473J	C 602	CCSRCH102J50
R 803	RS1/16SS273J	C 603	CSZS4R7M10
R 901	RS1/16SS221J	C 604	CSZS4R7M10
R 902	RS1/16SS221J	C 701	CKSSYB104K10
R 903	RS1/16SS221J	C 702	CKSSYB471K50
R 904	RS1/16SS221J	C 703	CKSSYB103K16
R 905	RS1/16SS221J	C 704	CEV1R0M50
R 906	RS1/16SS221J	C 705	CKSSYB104K10
<b>CAPACITORS</b>			
C 101	CKSSYB104K10	C 706	CKSSYB471K50
C 102	CKSSYB104K10	C 707	CKSSYB104K10
C 103	CEV101M16	C 708	CKSSYB104K10
C 104	CEV101M4	C 709	CKSSYB103K16
C 105	CKSSYB104K10	C 710	CKSSYB104K10
C 106	CKSRYB102K50	C 711	10µF/10V CCH1349
C 108	CKSSYB104K10	C 712	CKSRYB224K16
C 109	CEV100M16	C 713	CKSSYB104K10
C 201	CKSSYB471K50	C 714	CKSSYB104K10
C 202	CKSSYB104K10	C 715	CKSSYB103K16
C 203	CKSSYB104K10	C 716	CKSSYB103K16
C 204	CEV220M6R3	C 901	CKSSYB104K10
C 205	CKSSYB103K16	C 903	CCSRCH101J50
C 206	CKSSYB103K16	<b>Miscellaneous Parts List</b>	
C 207	CEV221M4		
C 208	CKSSYB104K10	M 1	Pickup Unit(Service)(P9MP3) CXX1550
C 209	CKSSYB104K10	M 2	Motor Unit(SPINDLE) CXB6007
C 210	CKSSYB104K10	M 951	Motor Unit(LOADING/CARRIAGE) CXB5903
C 211	CKSSYB104K10		Motor Unit(AUTOMATIC FLAP) CXB8939
C 216	CKSSYB332K50		



## 6. ADJUSTMENT

### 6.1 JIG CONNECTION DIAGRAM

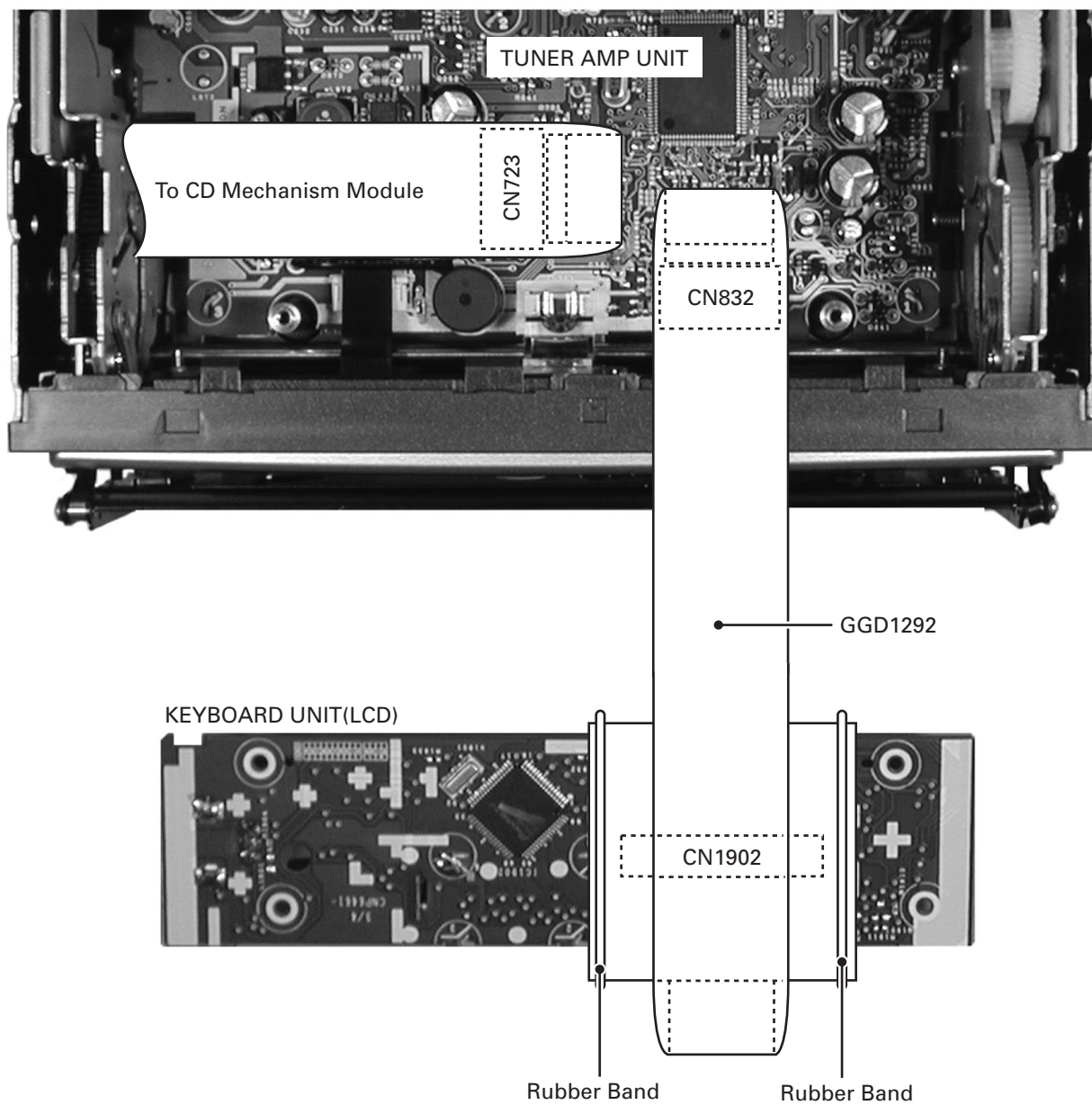

## 6.2 OEL UNIT ADJUSTMENT



### ● Adjustment point

KEYBOARD UNIT(OEL) (SIDE B)

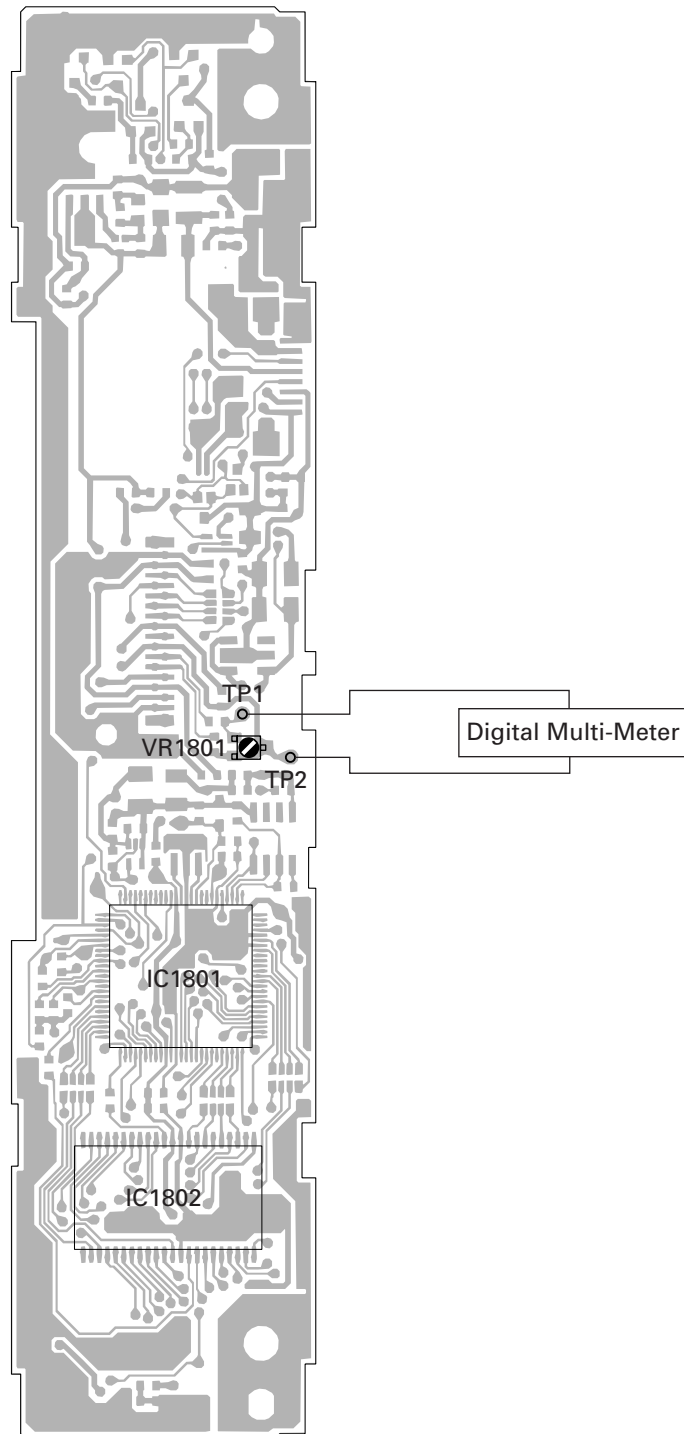

<When the OEL Unit has been replaced>

1. Use VR1801 to adjust the resistance between TP1 and TP2 to 6.1k $\Omega$ .

## 6.3 CD ADJUSTMENT

### 1) Precautions

- This unit uses a single power supply (+3.3V) for the regulator. The signal reference potential, therefore, is connected to REFO1 (approx. 1.65V) instead of GND.

If REFO1 and GND are connected to each other by mistake during adjustments, not only will it be impossible to measure the potential correctly, but the servo will malfunction and a severe shock will be applied to the pick-up. To avoid this, take special note of the following.

Do not connect the negative probe of the measuring equipment to REFO1 and GND together. It is especially important not to connect the channel 1 negative probe of the oscilloscope to REFO1 with the channel 2 negative probe connected to GND.

Since the frame of the measuring instrument is usually at the same potential as the negative probe, change the frame of the measuring instrument to floating status.

If by accident REFO1 comes in contact with GND, immediately switch the regulator or power OFF.

- Always make sure the regulator is OFF when connecting and disconnecting the various filters and wiring required for measurements.
- Before proceeding to further adjustments and measurements after switching regulator ON, let the player run for about one minute to allow the circuits to stabilize.
- Since the protective systems in the unit's software are rendered inoperative in test mode, be very careful to avoid mechanical and /or electrical shocks to the system when making adjustment.
- The RFI and RFO signals are easy to oscillate because of a wide band. When observing them, insert a resistor of about 1 k $\Omega$  to the series.
- This equipment will not guarantee the load ejection operation when the mechanical unit is turned upside down. In particular, if the ejection operation is incorrectly performed and recovery is disabled, the recovery is enabled by resetting a product or turning ACC off to on.

### 2) Test Mode

This mode is used for adjusting the CD mechanism module of the device.

- Test mode starting procedure  
Reset while pressing the **4** and **6** keys together.
- Test mode cancellation  
Switch ACC, back-up OFF.
- After pressing the EJECT key, do not press any other key until the disk is completely ejected.
- If the **▶** or **◀** key is pressed while focus search is in progress, immediately turn the power off (otherwise the actuator may be damaged due to adhesion of the lenses).
- Jump operation of TRs other than 100TR continues after releasing the key. CRG move and 100TR jump operations are brought into the "Tracking close" status when the key is released.
- Powering Off/On resets the jump mode to "Single TR(91)", the RF AMP gain setting to 0 dB, and the automatic adjustment value to the initial value.

● Flow Chart

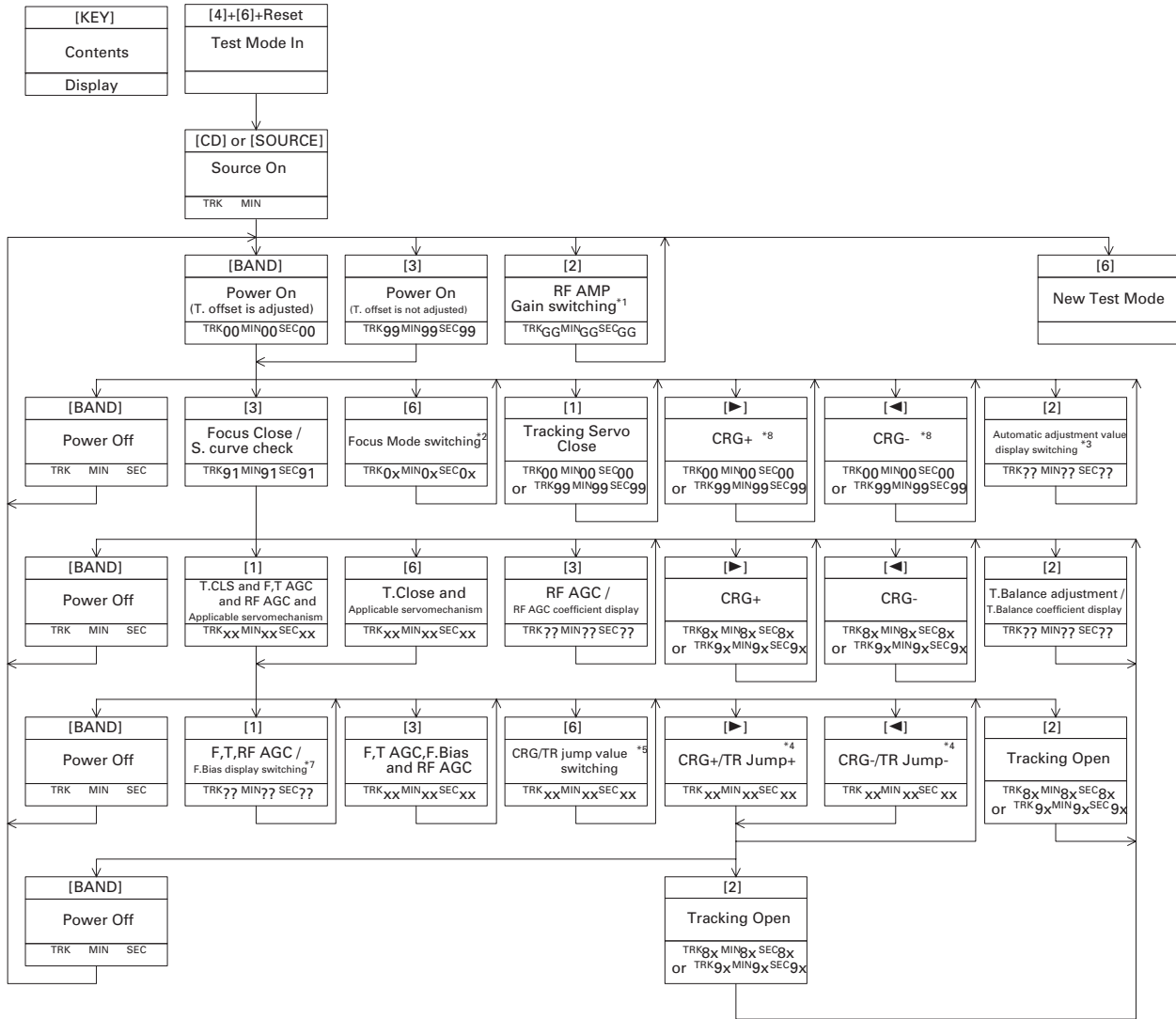

- \*1)  $\begin{matrix} \text{TYP} \\ \text{TRK} & \text{MIN} & \text{SEC} \end{matrix} \rightarrow \begin{matrix} +12\text{dB} \\ \text{TRK}_{12} & \text{MIN}_{12} & \text{SEC}_{12} \end{matrix}$
- \*2) Focus Close setting  $\begin{matrix} \text{TRK}_{00} & \text{MIN}_{00} & \text{SEC}_{00} \\ \text{or TRK}_{99} & \text{MIN}_{99} & \text{SEC}_{99} \end{matrix} \rightarrow \begin{matrix} \text{S. curve check setting} \\ \text{TRK}_{01} & \text{MIN}_{01} & \text{SEC}_{01} \end{matrix} \rightarrow \begin{matrix} \text{F. EQ measurement setting} \\ \text{TRK}_{02} & \text{MIN}_{02} & \text{SEC}_{02} \end{matrix}$
- \*3) F.Offset Display  $\rightarrow$  T.Offset Display  $\rightarrow$  Switch to the order of the original display
- \*4) 1TR/32TR/100TR
- \*5)  $\begin{matrix} \text{Single TR} \\ \text{TRK}_{91} & \text{MIN}_{91} & \text{SEC}_{91} \\ \text{or TRK}_{81} & \text{MIN}_{81} & \text{SEC}_{81} \end{matrix} \rightarrow \begin{matrix} \text{32TR} \\ \text{TRK}_{92} & \text{MIN}_{92} & \text{SEC}_{92} \\ \text{or TRK}_{82} & \text{MIN}_{82} & \text{SEC}_{82} \end{matrix} \rightarrow \begin{matrix} \text{100TR} \\ \text{TRK}_{93} & \text{MIN}_{93} & \text{SEC}_{93} \\ \text{or TRK}_{83} & \text{MIN}_{83} & \text{SEC}_{83} \end{matrix} \rightarrow \begin{matrix} \text{CRG Move} \\ \text{TRK}_{94} & \text{MIN}_{94} & \text{SEC}_{94} \\ \text{or TRK}_{84} & \text{MIN}_{84} & \text{SEC}_{84} \end{matrix}$
- \*6) Only at the time of CRG move or 100TR jump
- \*7)  $\text{TRK}/\text{MIN}/\text{SEC} \rightarrow \text{F.AGC Gain} \rightarrow \text{T.AGC Gain} \rightarrow \text{F.Bias} \rightarrow \text{RF AGC Gain}$
- \*8) CRG motor voltage = 2 [V]

[Key]	Operation	
	Test Mode	New Test Mode
[BAND]	Power On/Off	Error occurrence time/cause display switching
[▶]	CRG +/TR Jump+ (Direction of the external surface)	TRK+/FF
[◀]	CRG -/TR Jump- (Direction of the internal surface)	TRK-/REV
[1]	T.CLS and AGC and Applicable servomechanism/AGC,AGC display switching	SCAN
[2]	RF Gain switching/Offset adjustment display/T.Balance adjustment/T.OPN	MODE
[3]	F.CLS,S.Curve/Rough Servo and RF AGC/F,T,RF AGC	(ITP)
-	SPDL 1X/2X switching (Double-speed compatibility only)	-
-	Error rate measurement	-
[6]	F.Mode switching/T.CLS/CRG/TR Jump switching	Auto/Manual switching

## 6.4 CHECKING THE GRATING AFTER CHANGING THE PICKUP UNIT

### • Note :

The grating angle of the PU unit cannot be adjusted after the PU unit is changed. The PU unit in the CD mechanism module is adjusted on the production line to match the CD mechanism module and is thus the best adjusted PU unit for the CD mechanism module. Changing the PU unit is thus best considered as a last resort. However, if the PU unit must be changed, the grating should be checked using the procedure below.

### • Purpose :

To check that the grating is within an acceptable range when the PU unit is changed.

### • Symptoms of Mal-adjustment :

If the grating is off by a large amount symptoms such as being unable to close tracking, being unable to perform track search operations, or taking a long time for track searching.

### • Method :

- |                       |                            |
|-----------------------|----------------------------|
| • Measuring Equipment | • Oscilloscope, Two L.P.F. |
| • Measuring Points    | • E, F, REFO1              |
| • Disc                | • ABEX TCD-782             |
| • Mode                | • TEST MODE                |

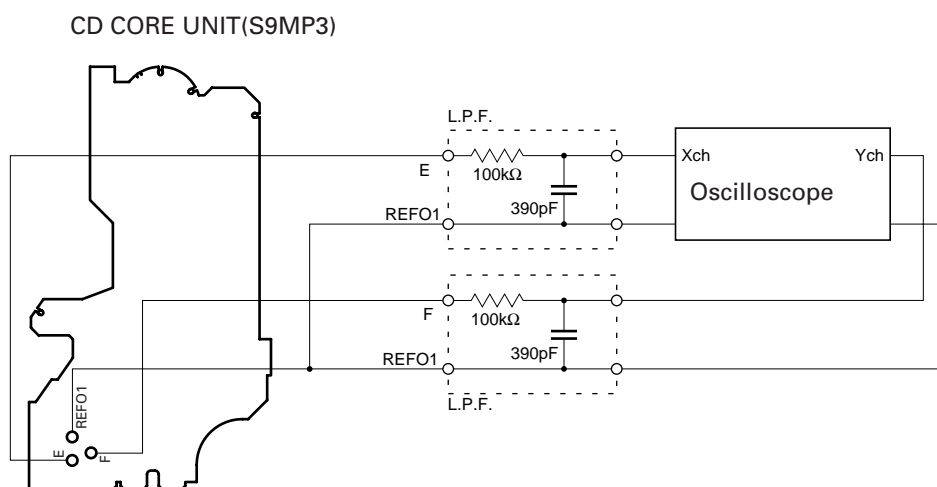

### • Checking Procedure

1. In test mode, load the disc and switch the 5V regulator on.
2. Using the ► and ◀ buttons, move the PU unit to the innermost track.
3. Press key **3** to close focus, the display should read "91". Press key **2** to implement the tracking balance adjustment the display should now read "81". Press key **3**. The display will change, returning to "81" on the fourth press.
4. As shown in the diagram above, monitor the LPF outputs using the oscilloscope and check that the phase difference is within  $75^\circ$ . Refer to the photographs supplied to determine the phase angle.
5. If the phase difference is determined to be greater than  $75^\circ$  try changing the PU unit to see if there is any improvement. If, after trying this a number of times, the grating angle does not become less than  $75^\circ$  then the mechanism should be judged to be at fault.

### • Note

Because of eccentricity in the disc and a slight misalignment of the clamping center the grating waveform may be seen to "wobble" ( the phase difference changes as the disc rotates). The angle specified above indicates the average angle.

### • Hint

Reloading the disc changes the clamp position and may decrease the "wobble".

**Grating waveform**

Ech → Xch 20mV/div, AC

Fch → Ych 20mV/div, AC

0°

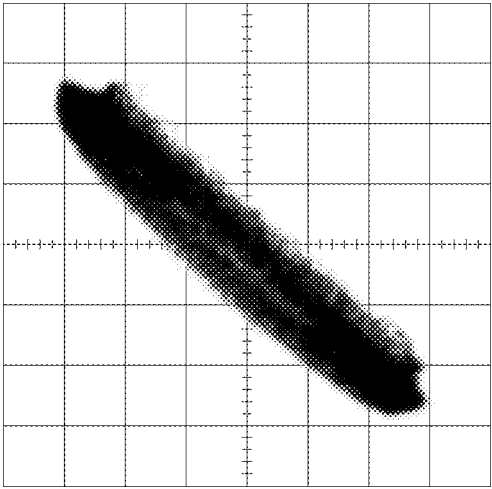

30°

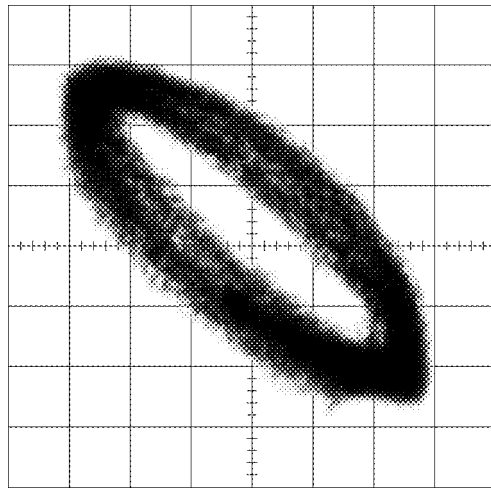

45°

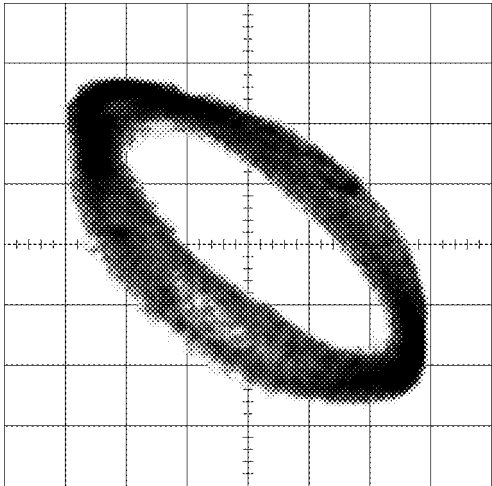

60°

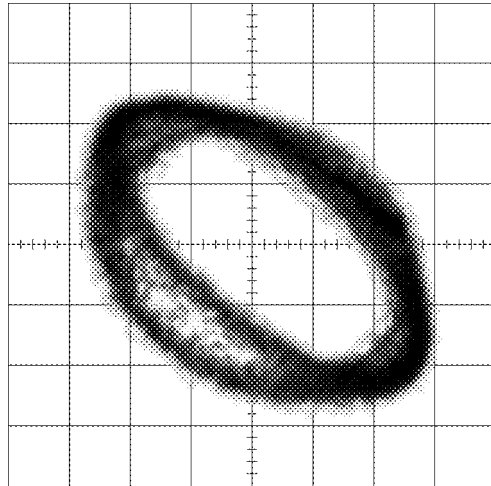

75°

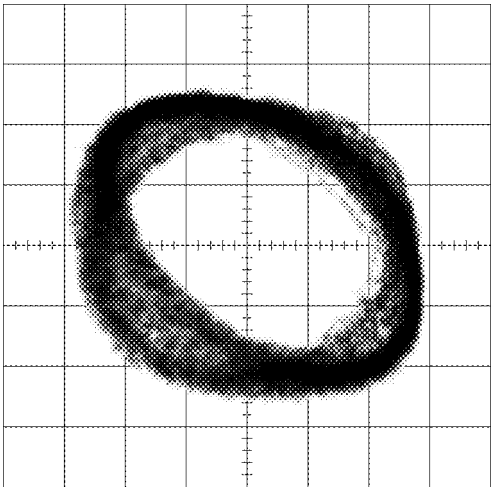

90°

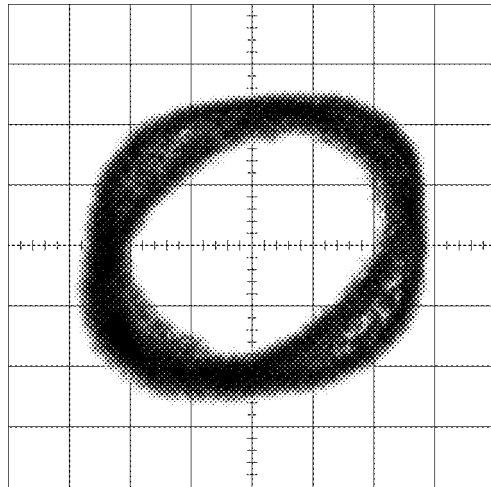

## 6.5 CD TEST MODE

### ● Error Messages

If a CD is not operative or stopped during operation due to an error, the error mode is turned on and cause(s) of the error is indicated with a corresponding number. This arrangement is intended at reducing nonsense calls from the users and also for facilitating trouble analysis and repair work in servicing.

#### (1) Basic Indication Method

1) When SERRORM is selected for the CSMOD (CD mode area for the system), error codes are written to DMIN (minutes display area) and DSEC (seconds display area). The same data is written to DMIN and DSEC. DTNO remains in blank as before.

#### 2) Head unit display examples

Depending on display capability of LCD used, display will vary as shown below. xx contains the error number.

8-digit display	6-digit display	4-digit display
ERROR-xx	ERR-xx	E-xx

#### (2) Error Code List

Code	Class	Displayed error code	Description of the code and potential cause(s)
10	Electricity	Carriage Home NG SERVO LSI Com- munication Error	CRG can't be moved to inner diameter. CRG can't be moved from inner diameter. → Failure on home switch or CRG move mechanism. Communication error between microcomputer and SERVO LSI.
11	Electricity	Focus Servo NG	Focusing not available. → Stains on rear side of disc or excessive vibrations on REWRITABLE.
12	Electricity	Spindle Lock NG Subcode NG	Spindle not locked. Sub-code is strange (not readable). → Failure on spindle, stains or damages on disc, or excessive vibrations. A disc not containing CD-R data is found. Turned over disc are found, though rarely. CD signal error.
17	Electricity	Setup NG	AGC protection doesn't work. Focus can be easily lost. → Damages or stains on disc, or excessive vibrations on REWRITABLE.
30	Electricity	Search Time Out	Failed to reach target address. → CRG tracking error or damages on disc.
44	Electricity	ALL Skip	Skip setting for all track. (CD-R/RW)
50	Mechanism	CD On Mech Error	Mechanical error during CD ON. → Defective loading motor, mechanical lock and mechanical sensor.
A0	System	Power Supply NG	Power (VD) is ground faulted. → Failure on SW transistor or power supply (failure on connector).

Remarks: Mechanical errors are not displayed (because a CD is turned off in these errors).

Unreadable TOC does not constitute an error. An intended operation continues in this case.

Upper digits of an error code are subdivided as shown below:

1x: Setup relevant errors, 3x: Search relevant errors, Ax: Other errors.

## ● New Test Mode

S-CD plays the same way as before.

If an error such as off focus, spindle unlocking, unreadable sub-code, or sound skipping occurs after setup, its cause and time occurred (in absolute time) are displayed.

During setup, operational status of the control software is displayed.

These displays and functions are prepared for enhancing aging in the servicing and efficiency of trouble analysis.

### (1) Shifting to the New Test Mode

- ① Turn on the current test mode by starting the reset from the key.
- ② Select S-CD for the source through the specified procedure including use of the [SOURCE] key, and inserting the disc. Then, press the [Jump Mode Selector] key while maintaining the regulator turned off.
- ③ After the above operations, the new test mode remains on irrespective of whether the S-CD is turned on or off.  
You can reset the new test mode by turning on the reset start.

### (2) Key Correspondence

Key	Test mode		New test mode	
	Regulator Off	Regulator On	In-play	Error Production
BAND	To regulator on	To regulator off	–	Time/Err.No. switching
▶	–	FWD-Kick	FF/TR+	–
◀	–	REV-Kick	REV/TR-	–
1	–	Tracking Close	Scan	–
2	–	Tracking Open	Mode	–
3	–	Focus Close	–	–
–	–	Focus Open	–	–
–	–	Jump Off	–	–
6	To new test mode	Jump mode switching	Auto/Manu	–

Note: Eject and CD on/off is performed in the same procedure as that for the normal mode.

### (3) Cause of Error and Error Code

Code	Class	Contents	Description and cause
40	Electricity	Off focus detected.	FOK goes low. → Damages/stains on disc, vibrations or failure on servo.
41	Electricity	Spindle unlocked.	LOCK = Low continued for 150 msec. → Damages/stains on disc, vibrations or failure on servo.
42	Electricity	Sub-code unreadable.	Sub-code was unreadable for 500 msec. → Damages/stains on disc, vibrations or failure on servo.
43	Electricity	Sound skipping detected.	Last address memory function was activated. → Damages/stains on disc, vibrations or failure on servo.

Note: Mechanical errors during aging are not displayed.



## (4) Display of Operational Status during Setup

Status No.	Contents	Protective action
21	Focus search start	Focus search timeout.
22	Focus search 2	Focus search timeout.
23	Focus search 3	Focus search timeout.
24	Focus search 4	Focus search timeout.
25	Focus search(Setup protection)	Focus slips off.
26	Focus search(Fast recovery)	Focus slips off.
27	RF detection	Focus slips off.
28	Spindle rough servocontrol	Focus slips off.
29	Tracking balance adjustment start	Focus slips off.
30	Tracking balance adjustment 2	Focus slips off.
31	Tracking balance adjustment 3	Focus slips off.
32	Tracking close start(Spindle stationary servocontrol setting)	Focus slips off.
33	Tracking close 2	Focus slips off.
34	Tracking close 3	Focus slips off.
35	Focus/Tracking AGC start	Focus slips off.
36	Focus/Tracking AGC 2	Focus slips off.
37	Focus/Tracking AGC 3	Focus slips off.
38	Focus/Tracking AGC 4	Focus slips off.
39	Focus/Tracking AGC 5	Focus slips off.
40	Focus/Tracking AGC 6	Focus slips off.
41	Focus/Tracking AGC 7	Focus slips off.
42	Focus/Tracking AGC 8	Focus slips off.
43	FE bias start	Focus slips off.
44	FE bias 2	Focus slips off.
45	RF AGC start	Focus slips off.
46	RF AGC 2	Focus slips off.
47	Lock check start	Focus slips off.
48	Lock is being checked	Focus slips off.
49	Subcode check start	Focus slips off, spindle lock is not performed.
50	Subcode is being checked	Focus slips off, no subcode can be read.

## (5) Display Examples

### 1) During Setup

8-digit display, 6-digit display	4-digit display(Auto setting)	4-digit display(Manual setting)
TNO. Min Sec	TNO.	Min Sec
11 11' 11"	11	11' 11"

### 2) During Operation (TOC read, TRK search, Play, FF and REV)

The same as in the normal mode.

### 3) When a Protection Error Occurred

#### (A) Error display ((A)←→(B), (C) : BAND key)

8-digit display	6-digit display	4-digit display
ERROR-xx	ERR-xx	E-xx

#### (B) Error occurrence timing display in track no. ((B)←→(C) : Auto/Manual key)

8-digit display, 6-digit display	4-digit display(Auto setting)
TNO. Min Sec	TNO.
10 40' 05"	10

#### (C) Error occurrence timing display in absolute time. ((B)←→(C) : Auto/Manual key)

8-digit display, 6-digit display	4-digit display(Manual setting)
TNO. Min Sec	Min Sec
10 40' 05"	40' 05"

## 7. GENERAL INFORMATION

### 7.1 DIAGNOSIS

#### 7.1.1 DISASSEMBLY

##### ● Removing the Case Unit (Fig.1)

**1** Remove the screw and then remove the Case Unit.

\*) Release the latches in order of the number indicated in Fig.1.

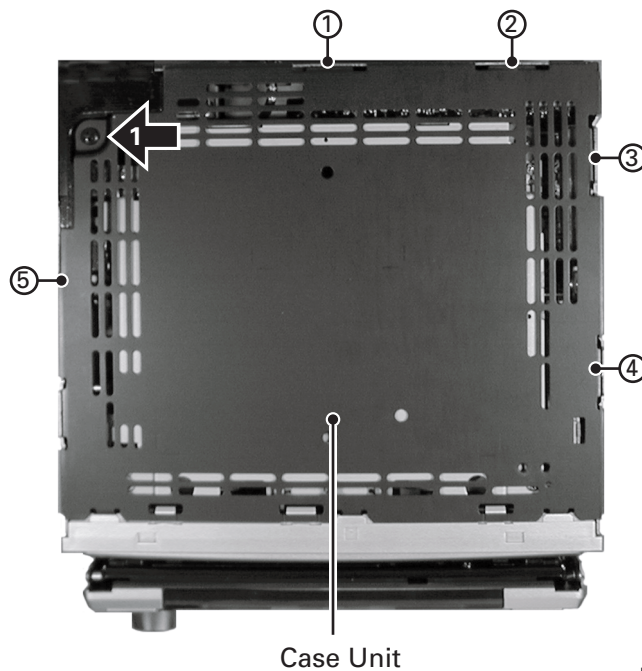

Fig.1

##### ● Removing the CD Mechanism Module (Fig.2)

**1** Remove the four screws.

Disconnect the connector and then remove the CD Mechanism Module.

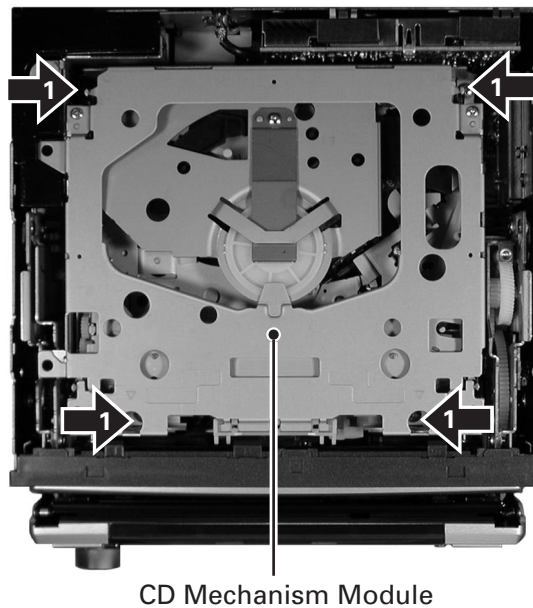

Fig.2

● **Moving the Arm Unit position (Fig.3)**

Use the finger. Rotate the gear in the direction indicated by arrow in Fig.3 until the Arm Unit moves to the 3 positions of a Fig.3.

\*) There is a possibility of bending if load is added to the arm parts, It becomes the cause of defect of move of the grille parts. When you place a product, please go in the CLOSE POSITION.

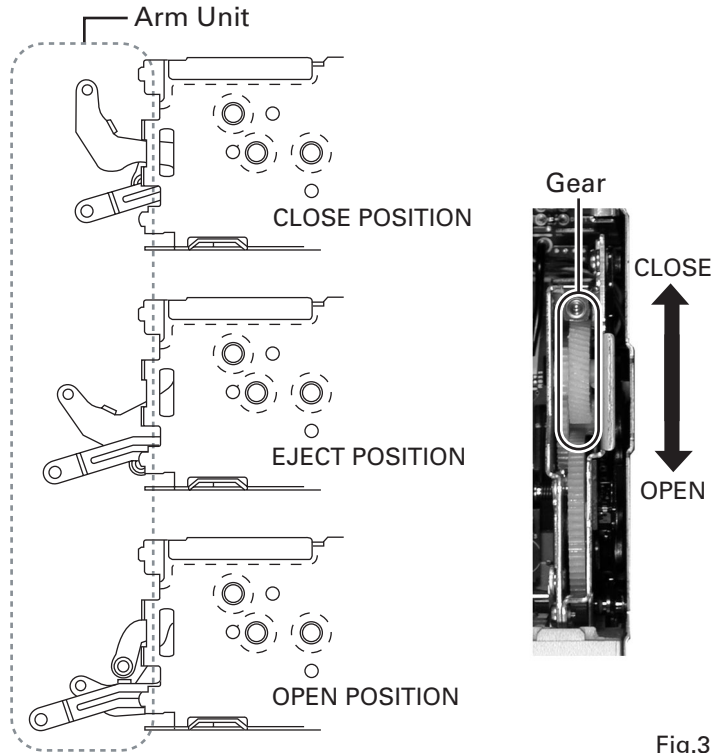

Fig.3

● **Removing the Detach Grille Assy and Grille Assy**

Move the Arm Unit to the OPEN POSITION. (Fig.3)

**1** Remove the two screws. (Fig.4)

Disconnect the connector and then remove the Detach Grille Assy.

\*) When installing the screws, please make sure that the spring is also installed.

**2** Remove the two screws. (Fig.4)

Move the Arm Unit to the EJECT POSITION. (Fig.3)

Disconnect the connector and then remove the Grille Assy.

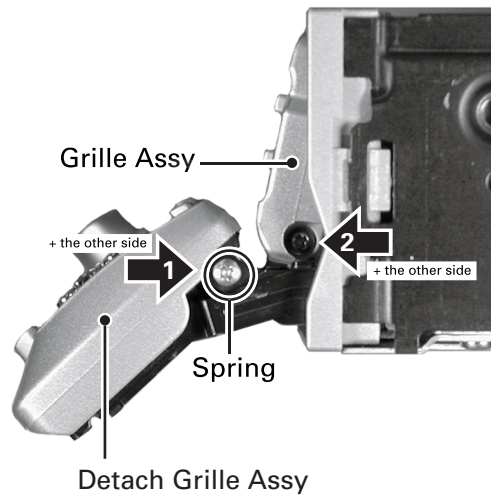

Fig.4

● **Removing the Panel Unit**

Move the Arm Unit to the OPEN POSITION. (Fig.3)

**1** Remove the two screws and then remove the Panel Unit. (Fig.5)

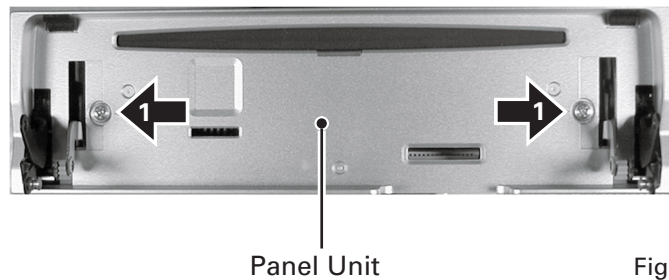

Fig.5

● **Removing the Gear Unit**

Move the Arm Unit to the CLOSE POSITION. (Fig.3)

- ➔ **1** Remove the four screws and then remove the Gear Unit. (Fig.6)

\*) When you remove or install the Gear Unit, do so with the Arm Unit in the CLOSE POSITION.

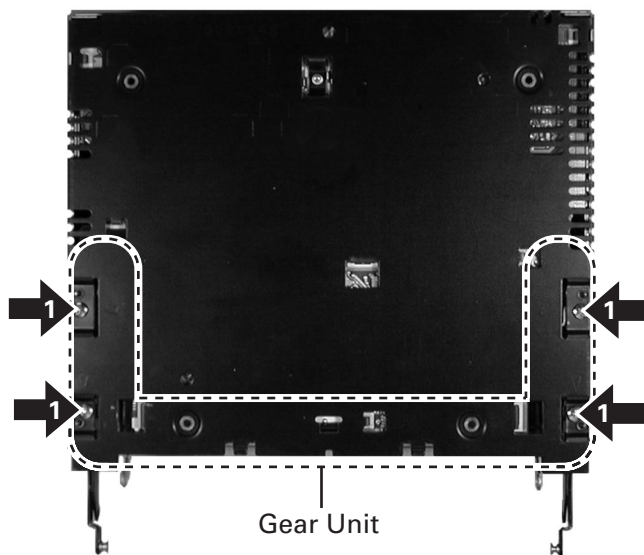
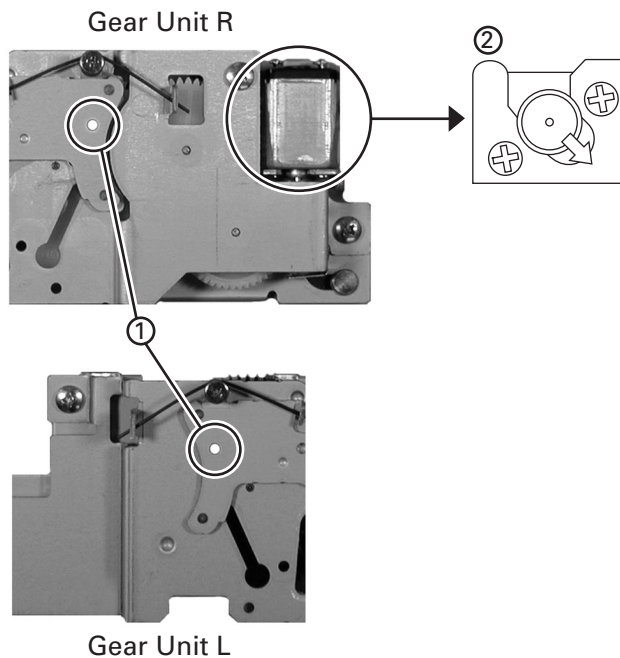

Fig.6

● **Checkpoints for the Gear Unit**

1. When you disassemble or assemble the Gear Unit, do so with the Arm Unit in the CLOSE POSITION.  
Make sure that the Arm Unit is in the CLOSE POSITION by seeing the other side of the unit through the fully circular hole shown in the figure.
2. When you install the motor, fix the screws holding the motor in the direction of the arrow shown in the figure.



● **Removing the Tuner Amp Unit (Fig.7)**

There are two ways of removing the Tuner Amp Unit.

One is to remove the Gear Unit (Fig.6), then Tuner Amp Unit, and the other is to remove the Panel (Fig.5), then Tuner Amp Unit.

**1** Remove the two screws.

Release the two latches and then remove the Holder.

**2** Remove the screw.

**3** Remove the two screws.

**4** Straight the tabs at three locations indicated.

**5** Remove the screw and then remove the Tuner Amp Unit.

\*) Tuner Amp Unit is different partially from this photo.

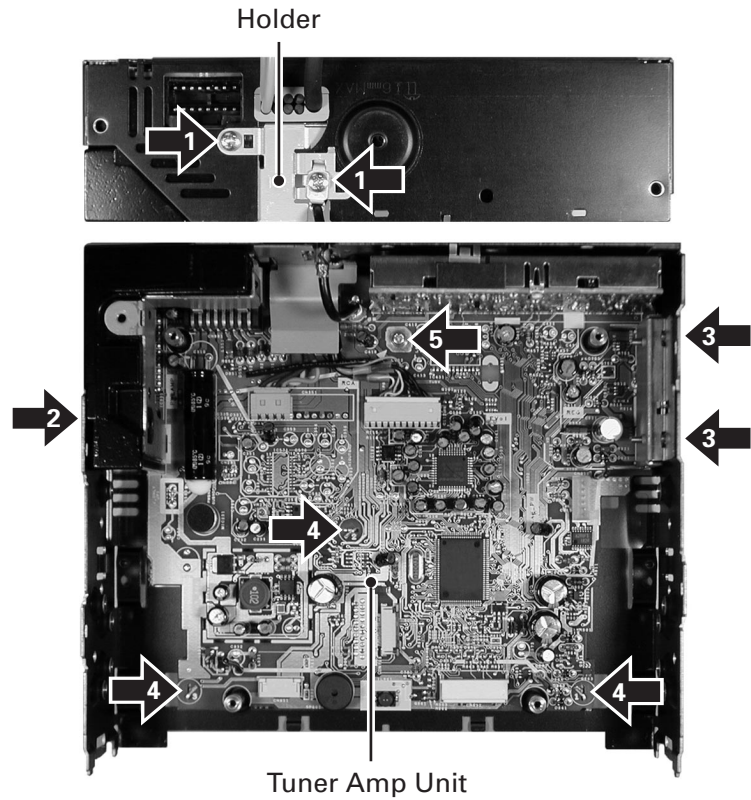

Fig.7

### ● Removing the OEL Unit

1. Apply hot air to the cable pins for the anode terminal using a blower used for removing a flat-packaged IC or something like that. When all the pins are peeling off from the PCB, pinch the cable with a pair of tweezers and remove it slowly from the PCB. (Fig.8)

\* Be careful not to remove other electrical parts when you use a blower. Especially, when hot air is appropriated to the VR1902 too much, the volume will destroy.

\* Flexible cable may not remove easily by transforming the Bosses by the hot air of the Blower.

2. Five tabs are extended until becoming straight in the direction of the arrow and then remove the Holder. (Fig.8)

3. Slowly set up the OEL Unit. At this time, the stress is prevented from hanging to flexible cable in the Cathode terminal. (Fig.9)

4. The Cathode terminal is removed according to the procedure same as the Anode terminal, and the OEL Unit is removed. (Fig.9)

5. Remove the Holder. (Remove after removing the Cathode terminal without fail.) (Fig.9)

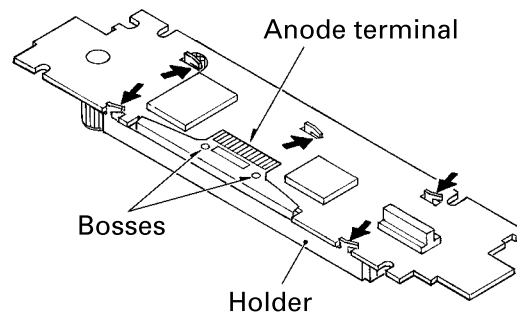

Fig.8

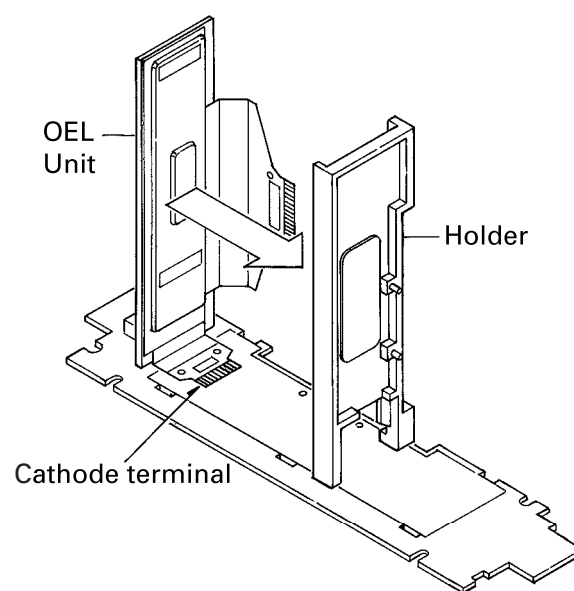

Fig.9

### ● Installing the OEL Unit

1. Install the Holder in the OEL Unit. (Fig.10)

2. When soldering the flexible cable for the Cathode terminal on the PCB, use a pair of tweezers. First, insert the tips of tweezers into 2 holes in the flexible cable, then into the 2 holes in the PCB. (Fig.10)

3. Position the flexible cable on the PCB so that their lands touch each other. (Fig.10)

4. Apply solder to each pin of the flexible cable. (Fig.10)

\* Appropriate soldering iron lightly so that the stress should not hang to Flexible cable.

5. Lay down the OEL Unit. (Fig.10)

6. Install the Holder. (Fig.8)

7. When soldering the flexible cable for the Anode terminal on the PCB, first, insert the Bosses on the PCB into the 2 holes in the flexible cable. Then, take the same procedures 2 and 3 as that for the Cathode terminal to solder the cable pins. (Fig.8)

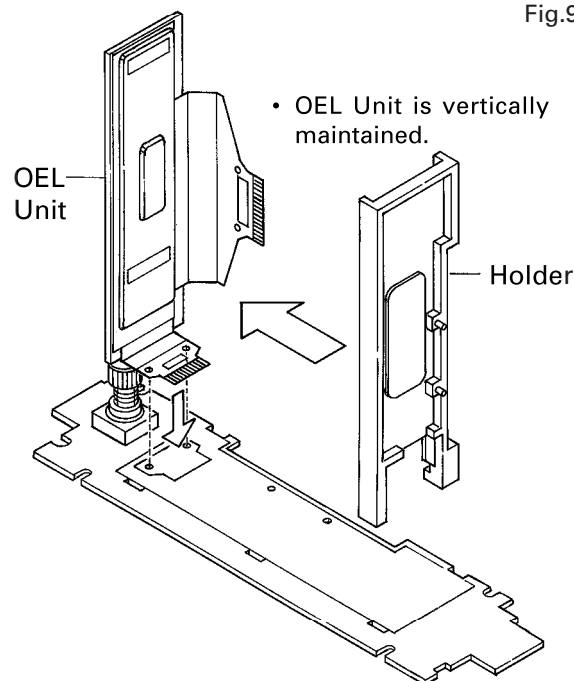
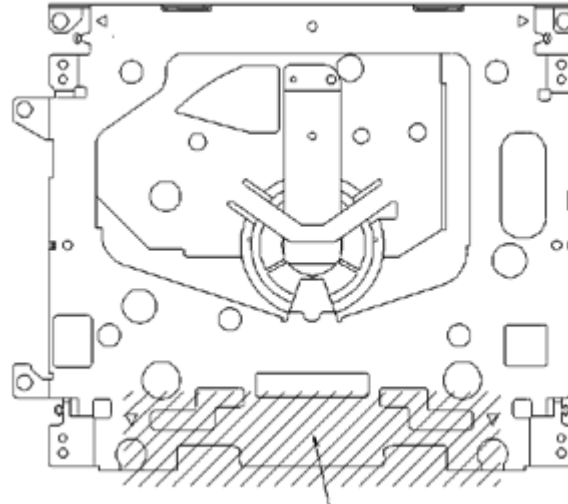

Fig.10

● **How to hold the Mechanical Unit**

1. Hold the top and bottom frame.
2. Do not squeeze top frame's front portion too tight, because it is fragile.



Do not squeeze.

● **How to remove the Top and Bottom Frame**

1. When the disk is in "clamp" state, unlock Spring A (6 pieces) and Spring B (2 pieces), and unscrew screws (4 pieces).
2. Unlock each 1 of pawl at the both side of the frame, then remove the top frame.
3. Remove the Carriage Mechanical part in such way that; you remove the mechanical part from 3 pieces of Damper while slowly pulling up the part.
4. Now, the top frame has been removed, and under this state, fix the genuine Connector again, and eject the disk.

(Caution)

When you reassemble the Carriage Mechanical part, apply a bit of alcohol to Dampers.

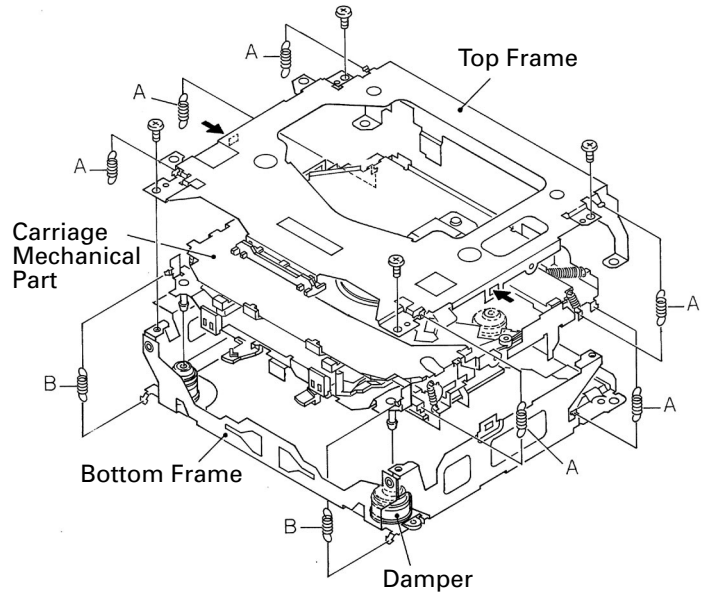

● **How to remove the Guide Arm Assy**

1. Unlock the spring (1 piece) at the right side of the assembly.
2. Unscrew screws (2 pieces), then remove the Screw Gear Bracket.
3. Shift the Guide Arm Assy to the left and slowly rotate it to the upper direction.
4. When the Guide Arm Assy rotates approximately 45 degree, shift the Assy to the right side direction and remove it.

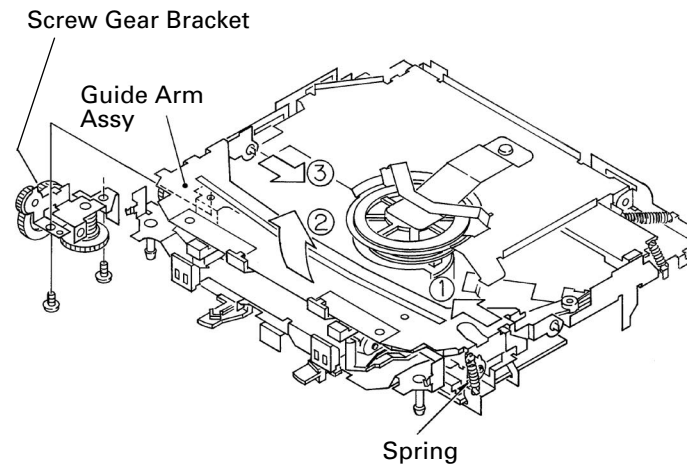



### ● How to remove the CD Core Unit(S9MP3)

1. Give jumper-solder treatment to the Flexible Wire of the Pickup unit, then remove the wire from the Connector.
2. Remove all 4 points of solder-treatment on the Lead Wire. Also, unscrew the screw(1 piece).
3. Then, Remove the CD Core Unit(S9MP3).

(Caution)

Be careful not to damage SW when you reassemble the CD Core Unit(S9MP3) into the device.

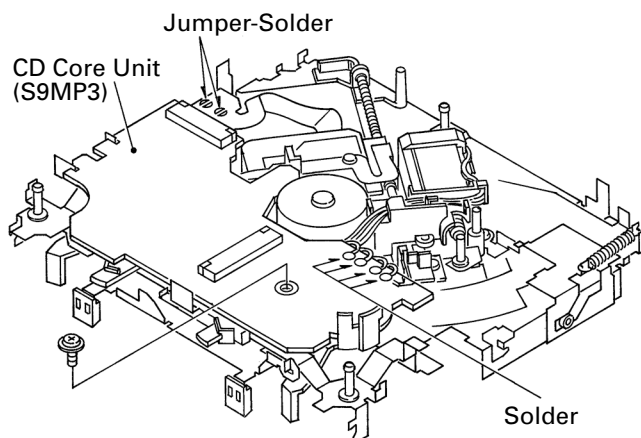

### ● How to remove the Loading Arm Assy

1. Unlock the spring (1 piece) and remove the E ring (1 piece) of the Fulcrum Shaft.
2. Shift the arm to the left side direction and unlock pins (2 pieces).

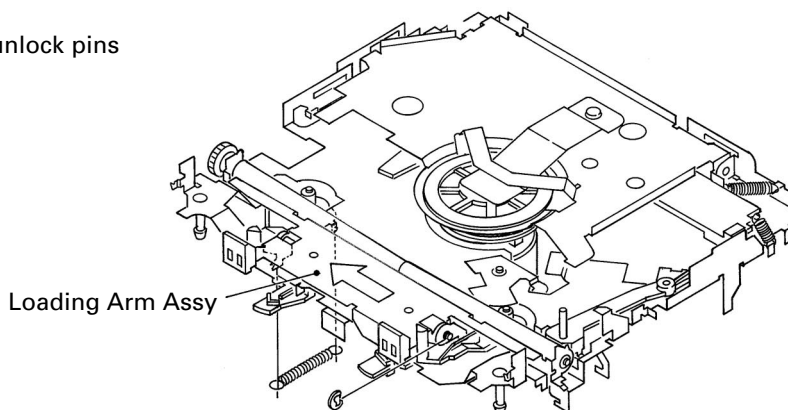

### ● How to remove the Pickup Unit

1. Unscrew 2 pieces of screws, then remove the Pulley Cover.
2. Remove the Feed Screw unit from the pawl of the Feed Screw Guide (The pawl is located inside the guide).
3. Remove the belt from the Pulley, then remove the Pickup unit.

(Caution)

Make sure not to stain the belt with grease when you fix the belt.

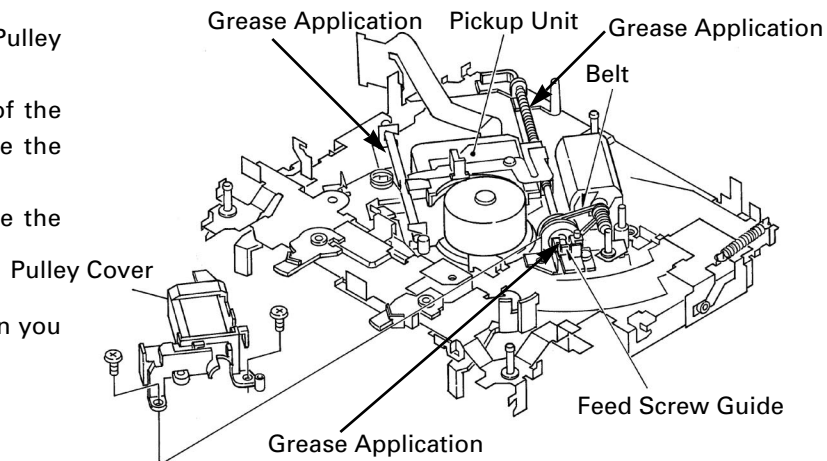

● Lubricants Points



(1) Drive Unit  
Grease (GEM1013) Application to all points.

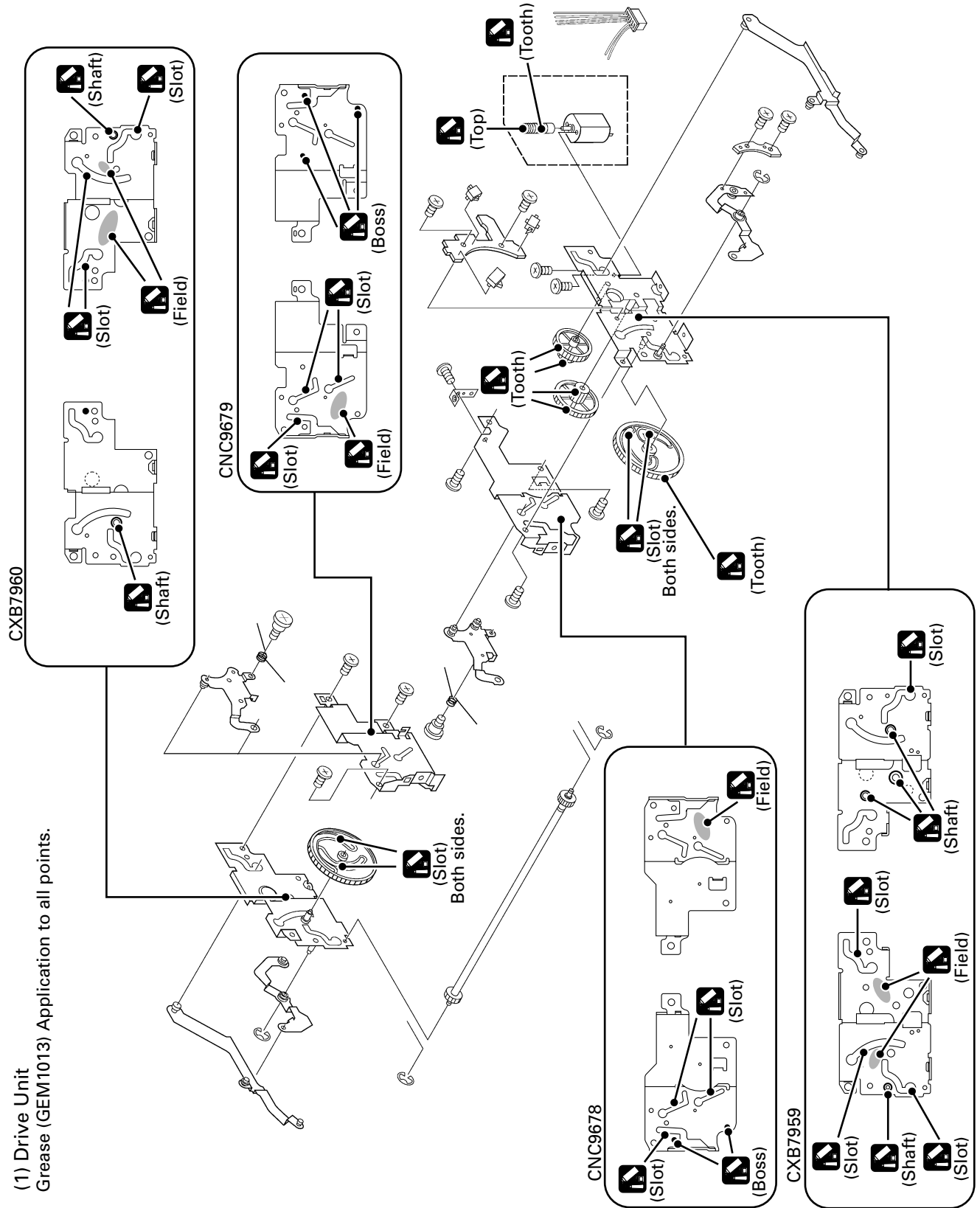

(2) Button (CAC7247)

Lubricants (GEM1016) Application to all points.

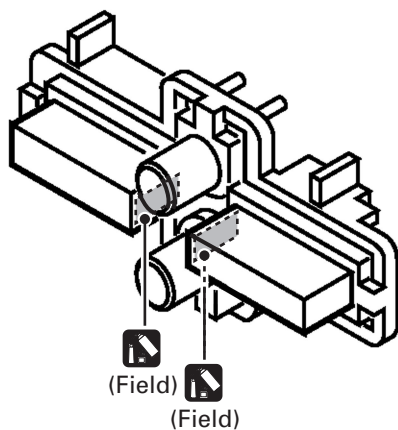

(3) Case Unit (CXB7968)

Lubricants (PN-38KE) Application to all points.

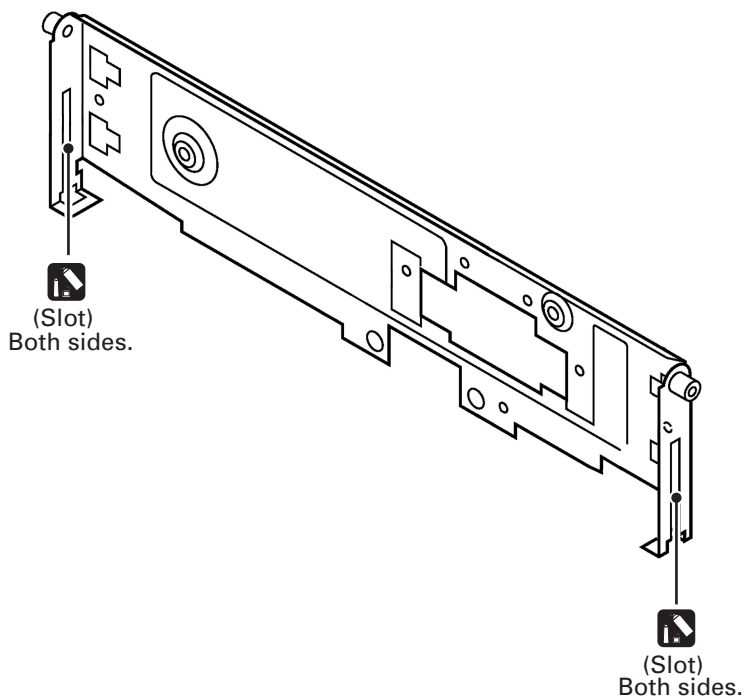

7.1.2 CONNECTOR FUNCTION DESCRIPTION

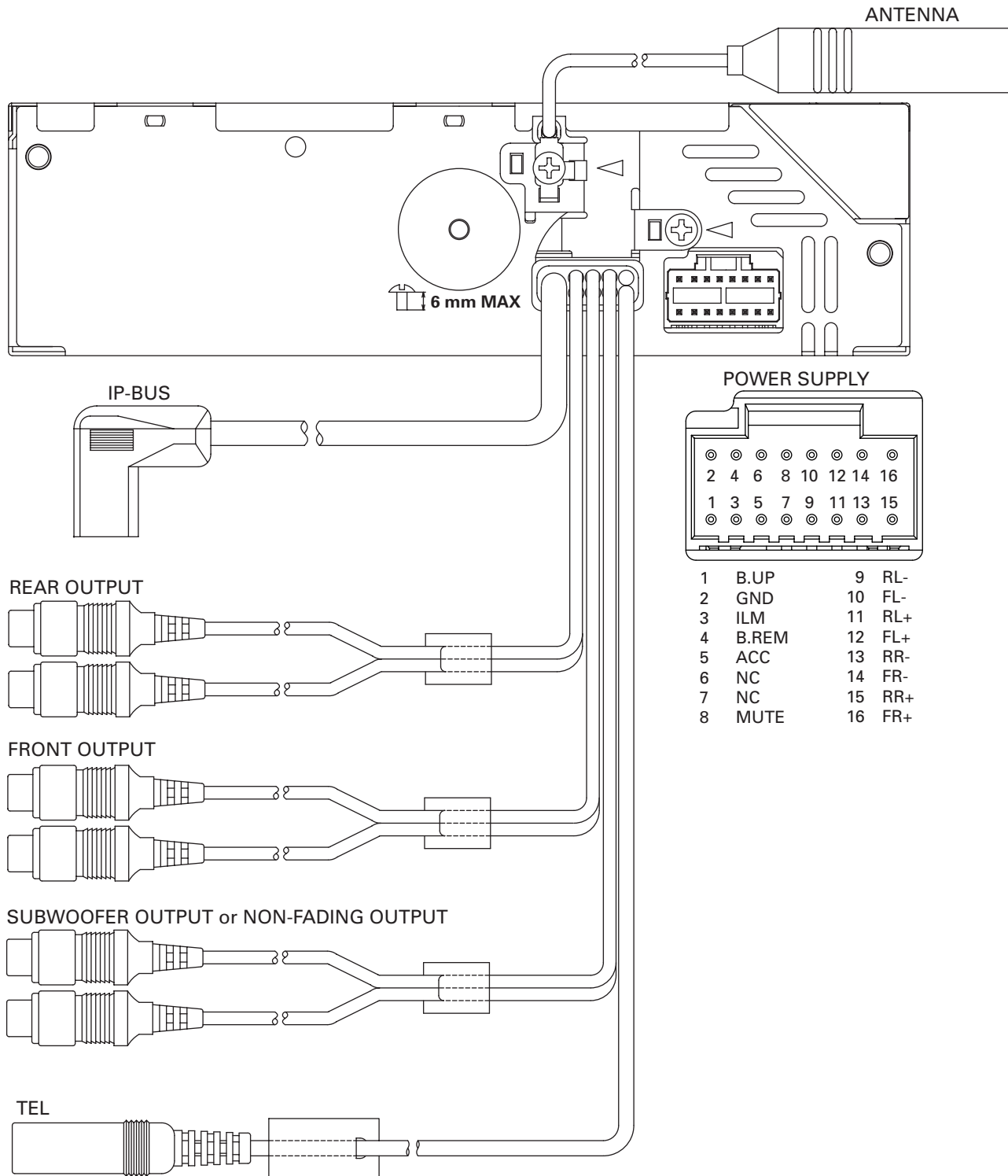

## 7.2 PARTS

### 7.2.1 IC

PD5740A	BA033SFP
PAL007A	BA5996FM
PD8091A	PE5269A
PD5745A	S-818A33AUC-BGN
PD6340A	BA25BC0WFP
UPD63760GJ	PD9023A
MSM51V4265EP-70TS	UPD61002GC

#### ● Pin Functions (PD5740A)

Pin No.	Pin Name	I/O	Function and Operation
1	BSO	O	P-BUS:Data output
2	$\overline{\text{BSCK}}$	O	P-BUS:Clock output
3	DUALILM	O	LCD:Illumination color select output
4	CD5VON	O	CDS:Eject sense output
5	VDT	O	EVOL:Data output
6	VST	O	EVOL:Strobe output
7	VCK	O	EVOL:Clock output
8	BYTE		Vss
9	VSS		Vss
10	TELIN	I	TEL:Telephone mute input
11	FLPPW	O	Auto flap motor power supply control output
12	RESET	I	Reset input(RESET)
13	XOUT	O	Clock output
14	VSS		Power supply input(Vss)
15	XIN	I	Clock input
16	VCC		Power supply input(Vcc)
17	NMI		Not used(Vcc)(Pull up)
18	$\overline{\text{RCK}}$	I	RDS:Clock input
19	$\overline{\text{LDET}}$	I	RDS:PLL lock detection input
20	DALMON	O	Consumption current reduction output
21	IPBUSIN2	I	IP-BUS:Input 2
22	OELPW	O	OEL Unit:Power supply output(16.5V)
23	SYSPW	O	System power control output
24	PEE	O	Beep tone output
25	RDS57K	I	RDS:57KHz pulse count input
26	ROMCS	O	External ROM:Chip select output
27	ROMCK	O	External ROM:Clock output
28	ROMDATA	I/O	External ROM:Data input / output
29	IPBUSIN	I	IP-BUS:Data input
30	IPBUSOUT	O	IP-BUS:Data output
31	DPDT1	O	OEL Unit:Grille microcomputer communication data output
32	KYDT1	I	OEL Unit:Grille microcomputer communication data input
33,34	NC		Not used
35	DPDT2	O	LCD:Grille microcomputer communication data output
36	KYDT2	I	LCD:Grille microcomputer communication data input
37, 38	ROT1, 0	I	Rotary encoder pulse input 1, 0
39	PCL	O	Clock adjustment output
40	SWVDD1	O	OEL Unit:Grille microcomputer power supply output(5.1V)
41	DISPPW	O	LCD:Power supply control output
42	ILMPW1	O	OEL Unit:Illumination power supply output(9.3V)
43	ILMPW2	O	LCD:Illumination power supply output
44	NC		Not used
45	$\overline{\text{DRST}}$	O	RDS:Reset output

# DEH-P8400MP

Pin No.	Pin Name	I/O	Function and Operation
46	RDSLK	I	RDS:Lock signal input
47	RDT	I	RDS:Data input
48	AM_FM	O	RDS:Decoder power supply control output
49	ST	I	TUNER:Stereo input
50	SD	I	TUNER:SD input
51	NL2DT	I	RDS:Noise level 2 input
52	TMUTE	O	RDS:Mute output
53	SDBW	I	RDS:In case of NF, SD input
54	LOCH	O	Local H output
55	TUNPDO	O	TUNER:PLL data output
56	TUNPDI	I	TUNER:PLL data input
57	TUNPCK	O	TUNER:PLL clock output
58	LOCL	O	Local L output
59	BRXEN	I/O	P-BUS:Communication input / output
60	BRST	O	P-BUS:Reset output
61	NC		Not used
62	VCC		Power supply input(Vcc)
63	NC		Not used
64	VSS		Connect to GND
65	FLPCLS	O	Auto flap close output
66	FLPOPEN	O	Auto flap open output
67	FLPEJSW	I	Auto flap eject sense input
68	FOPNSW	I	Auto flap open sense input
69	FCLSSW	I	Auto flap close sense input
70	FLPILM	O	DISC loading slot illumination output
71	TUNPCE2	O	TUNER:PLL chip enable output 2
72	TUNPCE	O	TUNER:PLL chip enable output
73	BSENS	I	Backup sense input
74	ASENS	I	ACC sense input
75	CURRO	O	RDS:Voltage FIX output
76-78	SMPXS2-0	O	Multiplexor select output 2-0
79	SWVDD2	O	LCD:Grille microcomputer power supply output(5V)
80	NC		Not used
81	IPPW	O	IP-BUS:Driver power supply control output
82	ASENBO	O	IP-BUS:Slave ACC sense output
83	ISENS	I	Illumination sense input
84	DIMMER	O	LCD:Dimmer output
85	BSRQ	I	P-BUS:Communication request input
86	NC		Not used
87	MUTE	O	Mute output
88	TESTIN	I	Test program input
89	SAIN	I	Spectrum Analyzer input
90	ASLIN	I	ASL input
91	MODEL	I	Model select input
92,93	NC		Not used
94	DSSENS	I	Detach sense input
95	NL1	I	RDS:Noise level input 1
96	AVSS		A/D converter power supply input(Vss)
97	SL	I	TUNER:Signal level input
98	VREF		A/D converter reference voltage(Vref)
99	AVCC		A/D converter power supply input(Vcc)
100	BSI	I	P-BUS:Data input

\*PD5740A

IC's marked by \* are MOS type.

Be careful in handling them because they are very liable to be damaged by electrostatic induction.

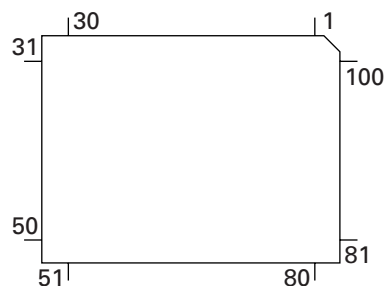

PAL007A

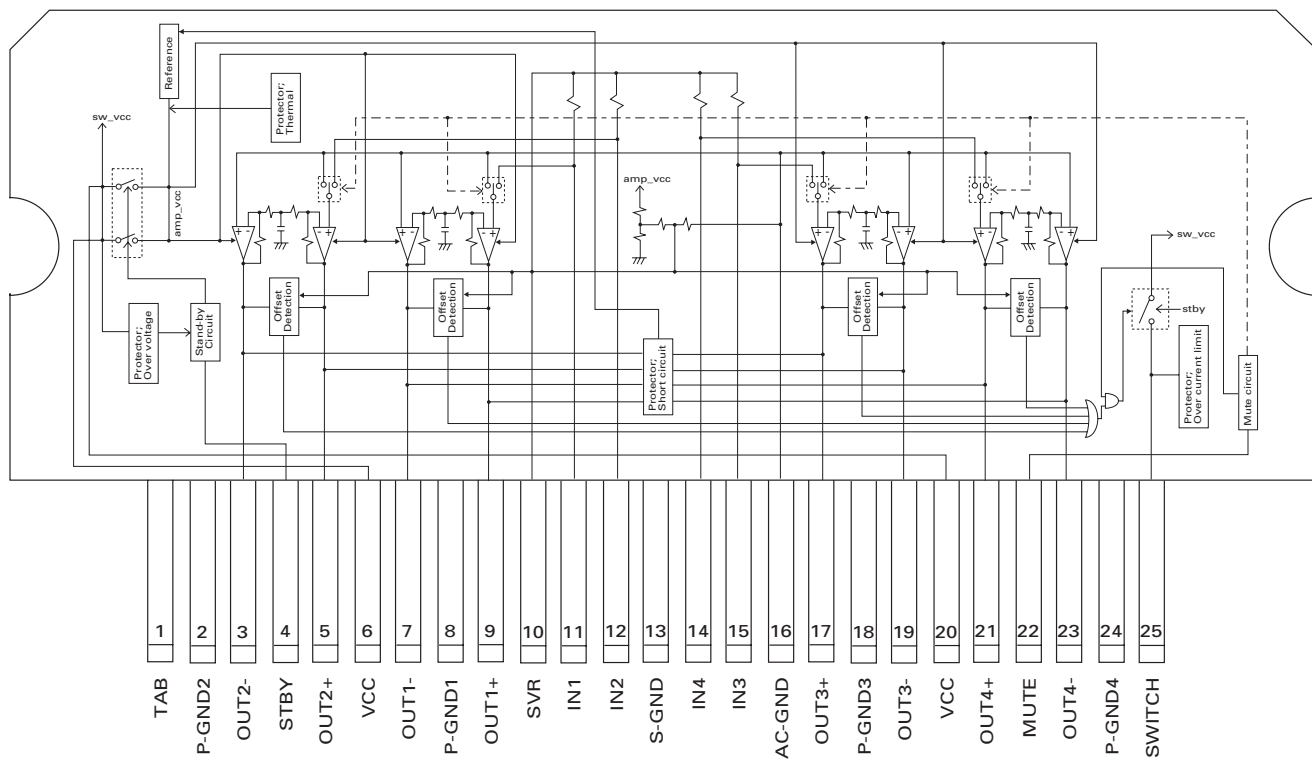

\*PD8091A

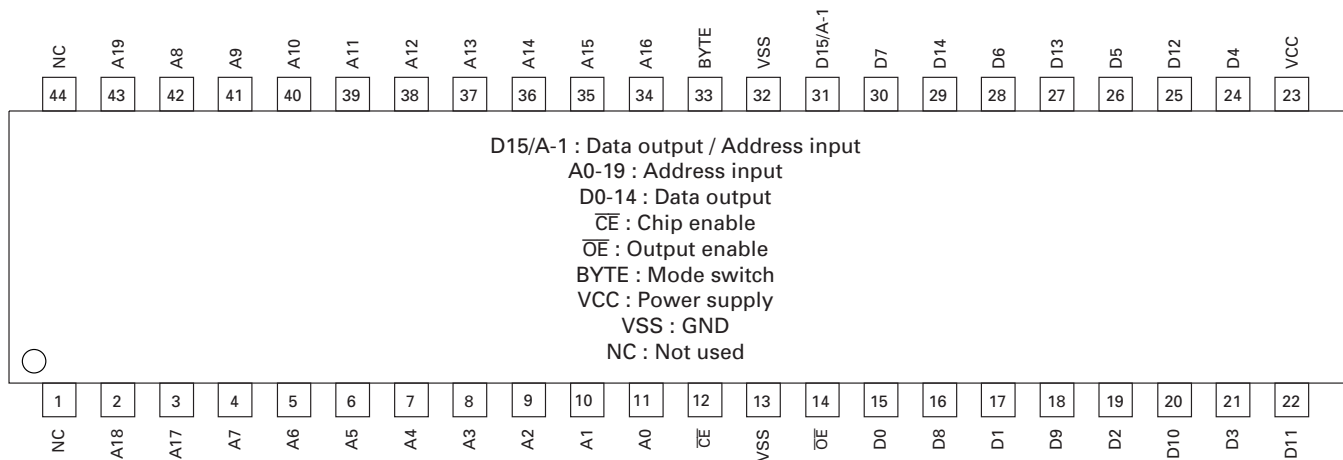

## ● Pin Functions (PD5745A)

Pin No.	Pin Name	I/O	Function and Operation
1-5	NC		Not used
6	BYTE	I	GND connection
7	CNVSS	I	GND connection
8, 9	NC		Not used
10	RESET	I	Reset input
11	XOUT	O	Crystal oscillating element connection pin
12	VSS		VSS connection
13	XIN	I	Crystal oscillating element connection pin
14	VDD		VDD connection
15	NMI	I	NVI input
16-19	NC		Not used
20	CKC	O	Fixed pulse output for cathode driver
21	NC		Not used
22	CKA	O	Fixed pulse output for anode driver
23	NC		Not used
24	LS	O	Line sink signal output
25	NC		Not used
26	CKD	O	Data transport / driver clock output
27	DPDT	I	Display data input
28	KYDT	O	Key data output
29	DA2	O	Display data MSB output
30	NC		Not used
31	CLK1	I	Clock input for UART1
32	ILMD	O	Dual illumination select output
33	DA1	O	Display data LSB output
34	NC		Not used
35	CLK0	I	Clock input for UART0
36	NC		Not used
37	RDY	I	Pull up
38	NC		Not used
39	HOLD	I	Pull up
40,41	NC		Not used
42	RD	O	Read strobe output
43-45	NC		Not used
46	CS2	O	Bank address select output
47	CS1	O	Bank address select output
48	CS0	O	External ROM chip select output
49	A19	O	Address bus 19 output
50	NC		Not used
51-59	A17-A9	O	Address bus 17-9 output
60	VDD		VDD connection
61	A8	O	Address bus 8 output
62	VSS		GND connection
63-69	A7-A1	O	Address bus 7-1 output
70	NC		Not used
71-86	D15-D0	I/O	Data bus 15-0 input / output
87,88	KS1,2	I/O	key strobe input / output
89-92	NC		Not used
93	KD2	I	key data input
94	AVSS		VSS connection
95	KD1	I	key data input
96	VREF		VSS connection
97	AVCC		VCC connection
98-100	NC		Not used



\*PD5745A

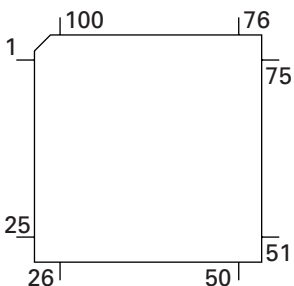

● Pin Functions (PD6340A)

Pin No.	Pin Name	I/O	Function and Operation
1-5	SEG4-0	O	LCD segment output
6-9	COM3-0	O	LCD common output
10	VLCD		LCD drive power supply
11-14	KST3-0	O	Key strobe output
15,16	KDT0,1	I	Key data input (analogue input)
17	REM	I	Remote control reception
18	DPDT	I	Display data input
19	NC		Not used
20	KYDT	O	Key data output
21	MODA		GND
22	X0		Crystal oscillator connection pin
23	X1		Crystal oscillator connection pin
24	VSS		GND
25,26	KDT2,3	I	Key data input
27	NC		Not used
28	KST4	O	Key strobe output
29-32	NC		Not used
33-55	SEG35-13	O	LCD segment output
56	VDD		Power supply
57-64	SEG12-5	O	LCD segment output

\*PD6340A

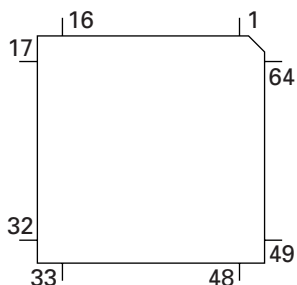

## ● Pin Functions (UPD63760GJ)

Pin No.	Pin Name	I/O	Function and Operation
1	R.GND		GND for DRAM I/F
2	RST	I	Input of reset
3-7	AB12-8	I	Address bus 12-8 from the microcomputer
8-15	AD7-0	I/O	Address/data bus 7-0 to the microcomputer
16	CS	I	Chip selection
17	ASTB	I	Address strobe
18	READ	I	Control signals (read)
19	WRITE	I	Control signals (write)
20	WAIT	O	Control signals (wait)
21	INTQ		Interruption signals to the external microcomputer
22	IFMODE	I	Switching between the data buses (16bit/8bit)
23	D.VDD		Power supply for digital circuits
24	XTALEN1	I	Permission to oscillate 16.9344MHz
25	XTALEN2	I	Permission to oscillate 24.576MHz
26	DA.VDD		Power supply for DAC
27	ROUT	O	Output of audio for the right channel
28	DA.GND		GND for DAC
29	R+	O	Output of the right channel audio PWM
30	R-	O	Output of the right channel audio PWM
31	REGC		Connected to the capacitor for band gap
32	L-	O	Output of the left channel audio PWM
33	L+	O	Output of the left channel audio PWM
34	DA.GND		GND for DAC
35	LOUT	O	Output of audio for the left channel
36	DA.VDD		Power supply for DAC
37	X.VDD		Power supply for the crystal oscillator
38	XTAL1		Connected to the crystal oscillator (16.9344MHz)
39	XTAL1		Connected to the crystal oscillator (16.9344MHz)
40, 41	X.GND		Ground for the crystal oscillator
42	XTAL2		Connected to the crystal oscillator (24.576MHz)
43	XTAL2		Connected to the crystal oscillator (24.576MHz)
44	X.VDD		Power supply for the crystal oscillator
45	D.GND		GND for digital circuits
46	DIN	I	Input of audio data
47	DOUT	O	Output of audio data
48	SCKIN	I	Clock input for audio data
49	SCKO	O	Clock output for audio data
50	LRCKIN	I	Input of LRCK for audio data
51	LRCK	O	Output LRCK for audio data
52	TESTX	O	Output for tests
53	RFOK	O	Output of RFOK
54	C16M	O	Output of 16.9344MHz
55	TESTEN	I	Connected to GND
56	TEST4	I	Connected to GND
57	D.VDD		Power supply for digital circuits
58	RFCK/HOLD	O	Output of RFCK/HOLD signal
59	WFCK/MIRR	O	Output of WFCK/MIRR signal
60	PLCK	O	Output of PLCK
61	LOCK	O	Output of LOCK
62	C1D1	O	Information on error correction
63	C1D2	O	Information on error correction
64	C2D1(RMUTE)	O	Information on error correction (mute for Rch)
65	C2D2(LMUTE)	O	Information on error correction (mute for Lch)
66	C2D3	O	Information on error correction
67	D.GND		Ground for digital circuits
68	RAS	O	Output of DRAM RAS

Pin No.	Pin Name	I/O	Function and Operation
69	CAS <sub>0</sub>	O	Output of DRAM Lower CAS
70	CAS <sub>1</sub>	O	Output of DRAM Upper CAS
71	WE	O	Output of DRAM WE
72	OE	O	Output of DRAM OE
73-88	RDB0-15	I/O	Input/output of DRAM Data0-15
89	D.GND		Ground for digital circuits
90-99	RA0-9	O	Output of DRAM Address0-9
100	D.VDD		Power supply for digital circuits
101-104	TEST0-3	I	Connected to GND
105	FD	O	Output of focus drive PWM
106	TD	O	Output of tracking drive PWM
107	SD	O	Output of thread drive PWM
108	MD	O	Output of spindle drive PWM
109	A.VDD		Power supply for the analog system
110	ATEST	O	Analog tests
111	EFM	O	Output of EFM signals
112	ASY	I	Input of asymmetry
113	C3T		Connection to the capacitor for detecting 3T
114	A.GND		Ground for the analog system
115	RFI	I	Input of RF
116	AGCO	O	Output of RF
117	AGCI	I	Input of AGC
118	RFO	O	Output of RF(AGC)
119, 120	EQ2, 1		Equalizer 2, 1
121	RF2-	I	Reversal input of RF2
122	RF-	I	Reversal input of RF
123	A.GND		Ground for the analog system
124	A	I	Input of A
125	C	I	Input of C
126	B	I	Input of B
127	D	I	Input of D
128	F	I	Input of F
129	E	I	Input of E
130	A.VDD		Power supply for the analog system
131	REFOUT	O	Output of reference voltage
132	REFC		Connected to the capacitor for output of REFOUT
133	FE-	I	Reversal input of FE
134	FEO	O	Output of FE
135	TE-	I	Reversal input of TE
136	TEO	O	Output of TE
137	TE2	O	TE2
138	TEC	I	TEC
139	A.GND		Ground for the analog system
140	LDREGO	O	Output of REG voltage for APC
141	PD	I	Input of PD
142	LD	O	Output of LD
143	PN	I	Assignment of pickup polarity
144	A.VDD		Power supply for the analog system

# DEH-P8400MP

\*UPD63760GJ

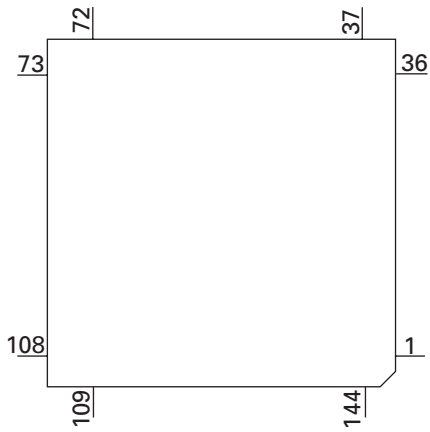

\*MSM51V4265EP-70TS

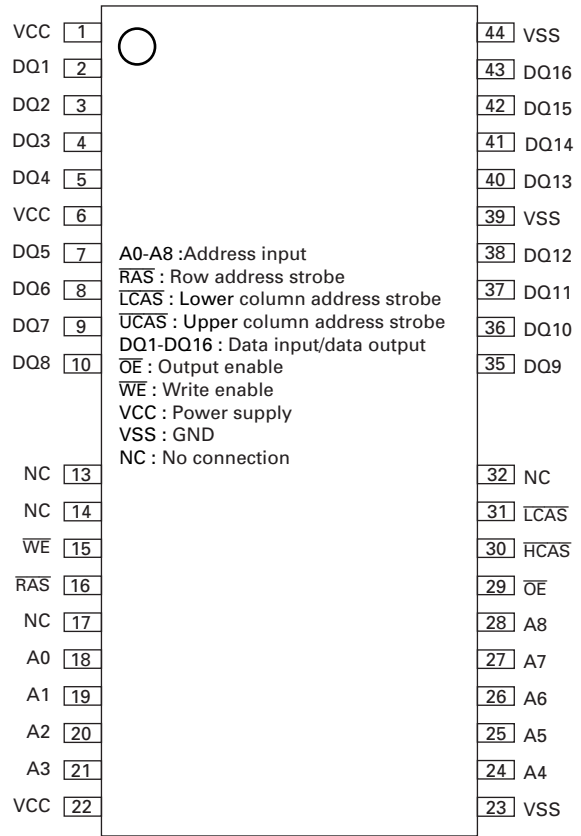

BA033SFP

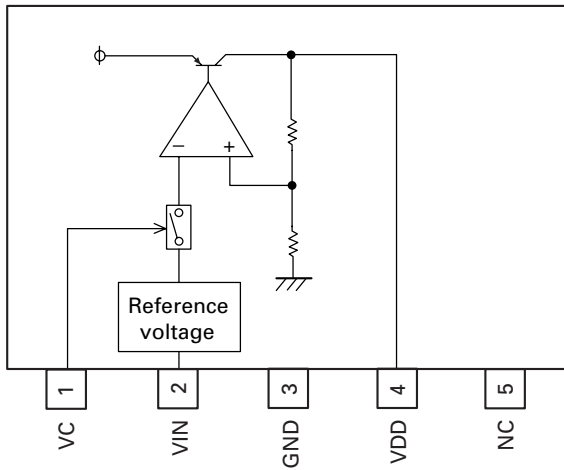

● Pin Functions(BA5996FM)

Pin No.	Pin Name	Function and Operation
1	VR	Input pin for reference voltage
2	OPIN2(+)	Input pin for non-inverting input for CH2 preamplifier
3	OPIN2(-)	Input pin for inverting input for CH2 preamplifier
4	OPOUT2	Output pin for CH2 preamplifier
5	OPIN1(+)	Input pin for non-inverting input for CH1 preamplifier
6	OPIN1(-)	Input pin for inverting input from CH1 preamplifier
7	OPOUT1	Output pin for CH1 preamplifier
8	GND	Ground pin
9	MUTE	Mute control pin
10	POWVCC1	Power supply pin for CH1, CH2, and CH3 at "Power" stage
11	VO1(-)	Driver CH1 - Negative output
12	VO1(+)	Driver CH2 - Positive output
13	VO2(-)	Driver CH2 - Negative output
14	VO2(+)	Driver CH2 - Positive output
15	VO3(+)	Driver CH2 - Positive output
16	VO3(-)	Driver CH2 - Negative output
17	VO4(+)	Driver CH4 - Positive output
18	VO4(-)	Driver CH4 - Negative output
19	POWVCC2	Power supply pin for CH4 at "Power" stage
20	GND	Ground pin
21	CNT	Control pin
22	LDIN	Loading input
23	OPOUTSL	Output pin for preamplifier for thread
24	OPINSL	Input pin for preamplifier for thread
25	OPOUT3	CH3 preamplifier output pin
26	OPIN3(-)	Input pin for inverting input for CH3 preamplifier
27	OPIN3(+)	Input pin for non-inverting input for CH3 preamplifier
28	PREVCC	PreVcc

BA5996FM

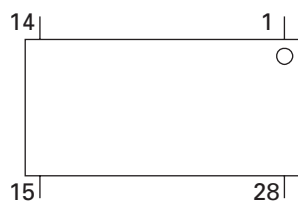

## ● Pin Functions (PE5269A)

Pin No.	Pin Name	I/O	Format	Function and Operation
1	FTXD	O	C	For rewriting Flash EP-ROM (sending signals)
2	NC			Open
3	BSI	I		Input of P-Bus serial data
4	BSO	O	C	Output of P-Bus serial data
5	B $\overline{\text{SCK}}$	I/O	/C	Input/output of P-Bus serial clock
6, 7	DFS1, 2	O	C	Output 1, 2 of settings of DA I/F IC sampling frequency
8	DCKS	O	C	Output for selection of DA I/F IC clock subharmonic number
9	EVDD			Positive power supply for E power
10	EVSS			Potential of GND of E power
11	NC			Open
12	DCOPY	O	C	Output of settings of DA I/F IC copy flag
13	$\overline{\text{CRST}}$	O	C	Output of reset control of Compression IC
14-16	CBANK0-2	O	C	Output 0-2 of bank settings of Compression IC
17	$\overline{\text{EMPH}}$	O	C	Output of information on emphasis
18	DSPMUTE	O	C	Output of DOUT Mute
19	DSET	O	C	Output for lighting the disc set indicator
20	ADENA	O	C	Output of control of A/D reference voltage supply
21	IC/VPP			IC: connected directly to VSS / VPP: Pull-down
22	BRXEN	I/O	/C	P-Bus receiving enabled
23	$\overline{\text{BSRQ}}$	I/O	/C	Request for P-Bus service request
24	XTALEN1	O	C	Output of permission to oscillate CD LSI 16.9344MHz
25	XTALEN2	O	C	Output of permission to oscillate CD LSI 24.576MHz
26	XRST	O	C	Output of control of CD LSI reset
27	VDCONT	O	C	Output of control of VD power supply
28	CD3VON	O	C	Output of control of CD +3.3V power supply
29	CONT	O	C	Output of control of power supply to servo driver
30	$\overline{\text{XWAIT}}$	I		Input of control signals of CD LSI wait
31	LOEJ	O	C	Output for switching between LOAD/EJECT directions
32	CLCONT	O	C	Output for switching between driver inputs
33	CDMUTE	O	C	Output of control of CD Mute
34	$\overline{\text{RESET}}$	I		Input of system reset
35	XT1	I		Connected to the oscillator for subclock (connected to VSS via the resistor)
36	XT2			Connected to the oscillator for subclock (Open)
37	REGC			Connected to the capacity stabilizing output of the regulator (an electrolytic capacitor of about 1 $\mu$ F)
38	X2			Connected to the oscillator for the main clock
39	X1	I		Connected to the oscillator for the main clock
40	VSS			Potential of GND
41	VDD			Positive power supply (5V)
42	CLKOUT	O	C	Output of internal system clock (Open)
43	XWRITE	O		Output of control signals of CD LSI light
44	$\overline{\text{UBEN}}$	O		Not used (Open)
45	WR/W	O		Output of Read/Write control signals of WMA decoder
46	$\overline{\text{XREAD}}$	O		Output of read control signals of CD LSI
47	XASTB	O		Output of CD LSI address strobe
48	LOCK	I		Input of spindle lock
49	$\overline{\text{WRST}}$	O	C	Output for reset control of WMA decoder
50-57	AD0-7	I/O	/C	Address/Data Bus 0-7
58	BVDD			B power supply, positive supply (3.3V)
59	BVSS			B power supply, potential of GND
60-67	AD8-15	I/O	/C	Address/Data Bus 8-15
68	XCS	O	C	Output for chip selection of CD LSI
69	$\overline{\text{WCS}}$	O	C	Output for chip selection of WMA decoder
70, 71	DBBWRDY0, 1	I		Input of write-ready flag with WMA decoder DBBIO, 1
72, 73	DBBRRDY0, 1	I		Input of read-ready flag with WMA decoder DBBO0, 1
74	AVDD			A power supply, positive supply (5V)
75	AVSS			A power supply, potential of GND

Pin No.	Pin Name	I/O	Format	Function and Operation
76	AVREF			Input of reference voltage for A/D converter
77	VDSSENS			Input of sensing short of VD power supply
78	DSCSNS			Input of sensing disc status
79	TEMP			Input of sensing information on temperature
80	HOME	I		Input of sensing Home SW
81	CSENS	I		Input of sensing the flap closed
82-85	NC			Connected to AVDD or AVSS via the resistor
86	WMAARI	I		Input of sensing existence of WMA decoder & DA I/F IC
87	DRAMARI	I		Input of sensing existence of external DRAM for CD LSI
88	TESTIN	I		Input with starting test program for checking chips
89	NC			Connected to EVDD or EVSS via the resistor
90	XINT			Input of interruption signals of CD LSI
91	WINT			Input of interruption signals of WMA decoder
92	BRST	I		Input of reset of P-Bus
93	EJSW	I		Input of Eject key
94-96	NC			Open
97	ROMDATA	I/O	/C	Input/output of E2PROM data
98	ROMCS	O	C	Output for chip selection of E2PROM
99	ROMCK	O	C	Output of clock of E2PROM
100	FRXD	I		For rewriting Flash EP-ROM (receiving signals)

\*PE5269A

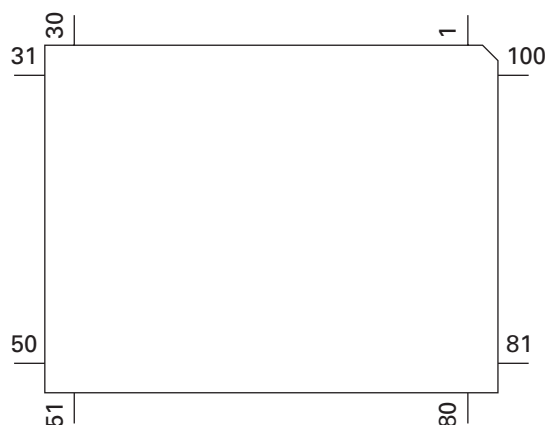

Format	Meaning
C	C MOS

# DEH-P8400MP

\*S-818A33AUC-BGN

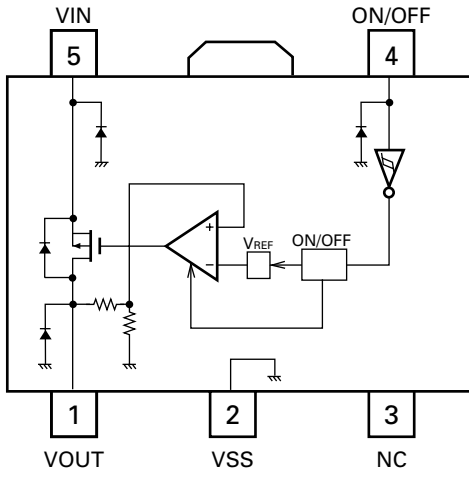

BA25BC0WFP

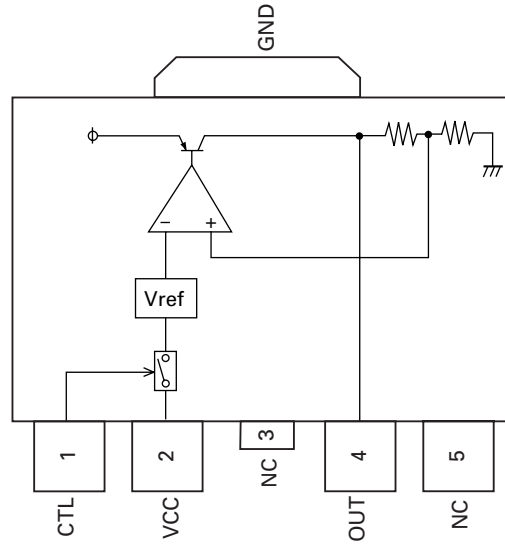

\*PD9023A

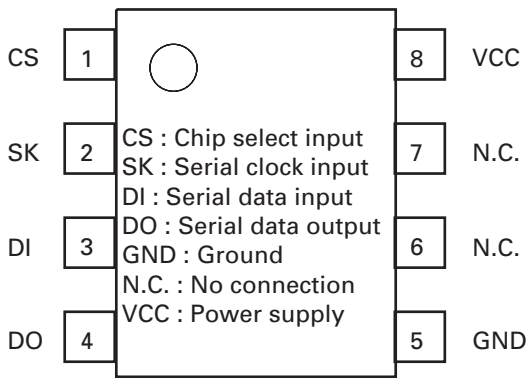



● **Pin Function (UPD61002GC)**

Pin No.	Pin Name	I/O	Function and Operation
1	VDD3	I/O	Power supply (3.3V)
2-4	NC		Not used
5	GND3		GND
6,7	NC		Not used
8	DO0	O	PCM output data
9	VDD2		Power supply (2.5V)
10	CKI	I	Clock input
11	DVDD		Power supply (PLL) (Digital)
12	AVDD		Power supply (PLL) (Analog)
13	AGND		GND (PLL) (Analog)
14	DGND		GND (PLL) (Digital)
15	VDD3I		Interface terminal protection
16	LRCKO	O	PCM output LRCK
17	BCKO	O	PCM output bit clock
18	NC		Not used
19	VDD3		Power supply (3.3V)
20	GND2		GND
21	MCK44	I	Audio master clock input
22	MCK48	I	Audio master clock input
23,24	P10, 11	I/O	Port
25	VDD2		Power supply (2.5V)
26	GND3		GND
27-32	P12-17	I/O	Port
33	VDD2		Power supply (2.5V)
34	P00/INTP00	I/O	Port
35,36	NC		Not used
37	P03/INTP03	I/O	Port
38	P04/INTP04	I/O	Port
39	P05/INTP05	I/O	Port
40	GND2		GND
41,42	P06, 07	I/O	Port
43	VDD3		Power supply (3.3V)
44-49	HAD0-5	I/O	Host address / Data bus
50	GND3		GND
51	VDD3		Power supply (3.3V)
52-55	HAD6-9	I/O	Host address / Data bus
56	GND3		GND
57-59	HAD10-12	I/O	Host address / Data bus
60	VDD2		Power supply (2.5V)
61-63	HAD13-15	I/O	Host address / Data bus
64	VDD3		Power supply (3.3V)
65	HAST	I	Host address strobe
66	HCSB	I	Host chip select
67	HR/WB	I	Host read / Write status
68	HDSTB	I	Host data strobe
69	GND2		GND
70	NC		Not used
71	EXTDIR	I	Bus direction flag from external
72,73	DBBWRDY0, 1	O	DBB write ready flag
74	DBBRRDY0	O	DBB read ready flag
75	VDD2		Power supply (2.5V)
76	GND3		GND
77	DBBRRDY1	O	DBB read ready flag
78	GND3		GND
79	RESETB	I	Reset
80	GND3		GND
81	VDD3		Power supply (3.3V)
82	GND3		GND
83	PLLCONT	I	PLL control
84	GND3		GND

# DEH-P8400MP

Pin No.	Pin Name	I/O	Function and Operation
85	NC		Not used
86	GND2		GND
87	DI3	I	PCM input data
88	LRCKI3	I	PCM input LRCK
89	BCKI3	I	PCM input bit clock
90	DI2	I	PCM input data
91	LRCKI2	I	PCM input LRCK
92	BCKI2	I	PCM input bit clock
93	DI1	I	PCM input data
94	LRCKI1	I	PCM input LRCK
95	BCKI1	I	PCM input bit clock
96	VDD2		Power supply (2.5V)
97	DI0	I	PCM input data
98	LRCKI0	I	PCM input LRCK
99	BCKI0	I	PCM input bit clock
100	GND2		GND

\*UPD61002GC

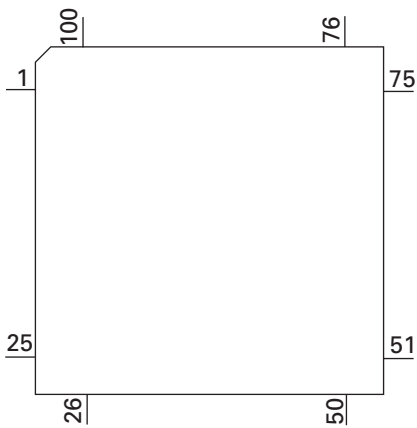

## ● FM/AM Tuner Unit

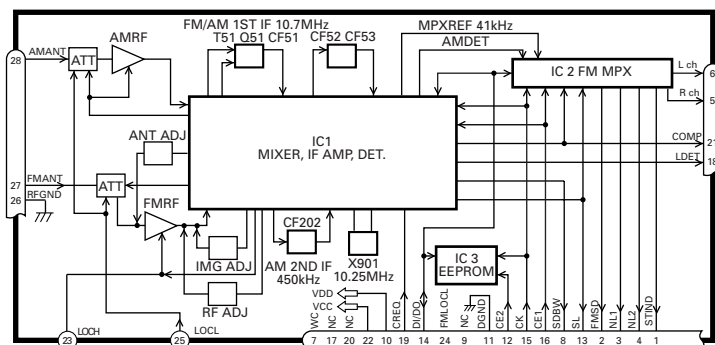

No.	Symbol	I/O	Explain	
1	STIND	O	stereo indicator	"Low" when the FM stereo signals are received. To be pulled up to the "VDD" at 47kΩ.
2	FMSD	O	FM station detector	"High" when signals are received. To be pulled up to the "VDD" at 47kΩ Meanwhile, 10kΩ should be used when taking diver FIX trigger from here and "High: 0.9VDD or more" and "Low: 250mV or less". (Should satisfy the diver IC specifications)
3	NL1	O	noise level-1	"High" when noise is received. Output for the RDS. GND at 47kΩ //1,800pF.
4	NL2	O	noise level-2	"High" when noise is received. Output for the RDS. GND at 36kΩ //330pF.
5	Rch	O	R channel output	FM stereo "R-ch" signal output or AM audio output. Add the specified de-emphasis constant.
6	Lch	O	L channel output	FM stereo "L-ch" signal output or AM audio output. Add the specified de-emphasis constant.
7	WC		write control	EEPROM write control. Writing permissible at "Low". Normally open.
8	SDBW	O	SD bandwidth	SD bandwidth signal output. For detection of detuning data for the RDS.
9	NC			Not used
10	VDD		power supply	Power supply pin for the digital section. DC 5V +/- 0.25V. Be careful about overlapping noise in the logic section.
11	DGND		digital ground	Grounding for the digital section.
12	CE2	I	chip enable-2	EEPROM chip enable. Active a "Low" To be pulled up to the "VDD" at 47kΩ
13	SL	I/O	signal level	Received FM/AM signal level (strength) output. Connect the specified load resistor and capacitor (10k Ω + 39k Ω //4,700pF)
14	DI/DO	I/O	data input/ data output	Data input/Data output To be pulled up to the "VDD" at 47kΩ
15	CK	I	clock	Clock input To be pulled up to the "VDD" at 47kΩ
16	CE1	I	chip enable-1	AF-RF chip enable. Active at "High" To be grounded at 47kΩ
17	NC			Not used
18	LDET	O	lock detector	Active at "Low". To be pulled up to the "VDD" at 47kΩ
19	CREQ	I	current request	Active at "Low". To be grounded at 47kΩ
20	NC			Not used
21	COMP	O	composite signal	FM composite signal output. r out < 100Ω
22	VCC		power supply	Analog section power supply pin.DC 8.4V +/- 0.3V
23	LOCH	I	local high	FM local high pin. When seeking local high, apply 5V together with "LOCL".
24	FMLOCL	I	FM local low	FM local low pin. When seeking local low, apply 5V to the base of the NPN transistor with which the specified resistor is being connected to the emitter. Keep it open in case of ordinary marketed models.
25	LOCL	I	local low	FM/AM local low pin. When seeking local low, apply 5V to the base of the NPN transistor. Since this pin is exclusive for AM when the FMLOCL is in use, do not drive it under FM.
26	RFGND		RF ground	Grounding for the antenna section.
27	FMANT	I	FM antenna input	FM antenna input. 75Ω. Surge absorber (DSP-201M-S00B) is necessary.
28	AMANT	I	AM antenna input	AM antenna input. High impedance. Connect to the antenna through an L (LAU type) of 4.7μH.To cope with the power transmission line hums, insert a series circuit consisting of an L (a coil of about 100mH) + R (a resistor of 470 Ω to 2.2kΩ) between the GND.

### 7.2.2 DISPLAY

● CAW1704

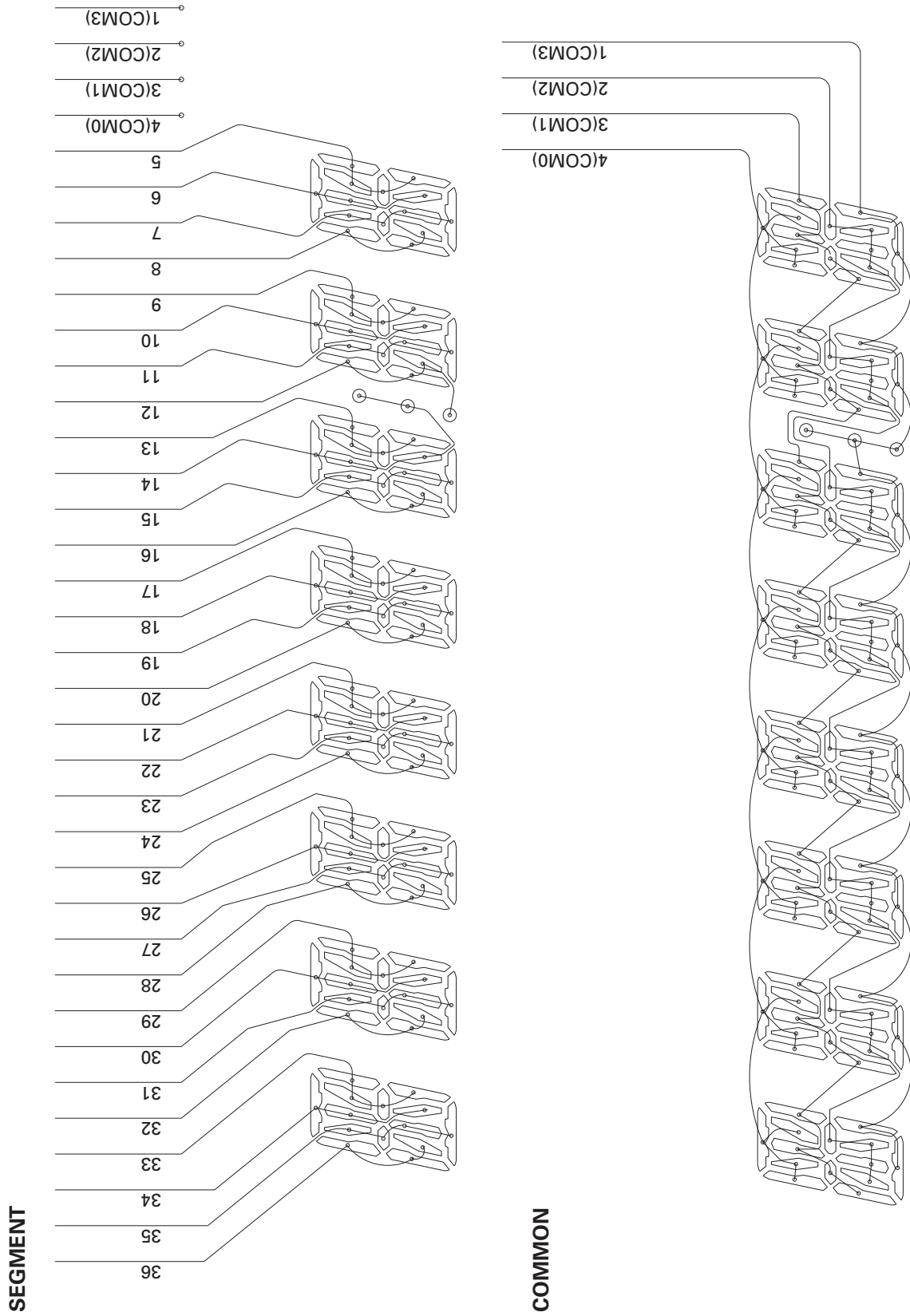

### 7.3 OPERATIONAL FLOW CHART

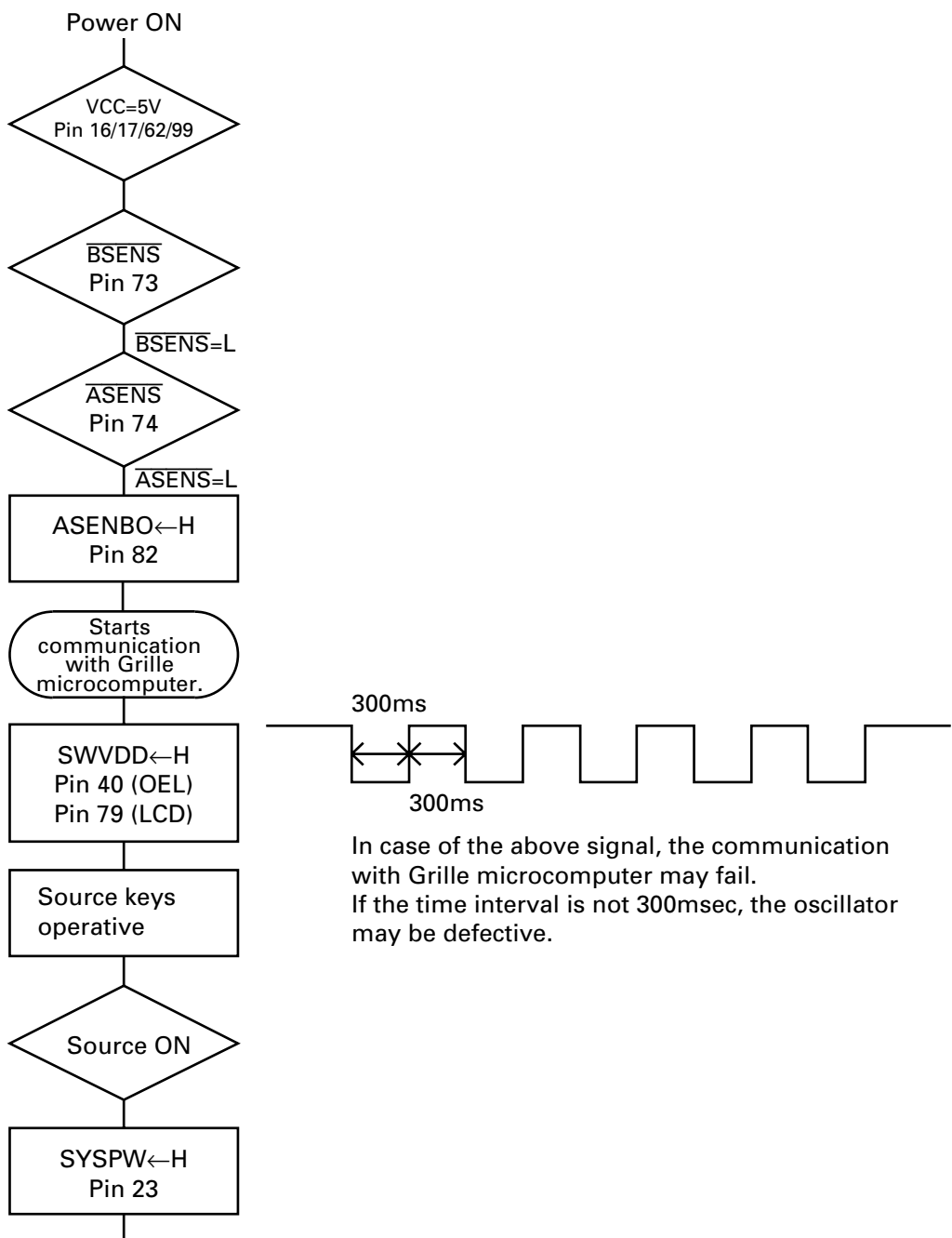

Completes power-on operation.  
(After that, proceed to each source operation)

### 7.4 CLEANING

Before shipping out the product, be sure to clean the following portions by using the prescribed cleaning tools:

Portions to be cleaned	Cleaning tools
CD pickup lenses	Cleaning liquid : GEM1004 Cleaning paper : GED-008

## 8. OPERATIONS AND SPECIFICATIONS

### 8.1 OPERATIONS

#### HEAD UNIT

##### ● CLOSE POSITION

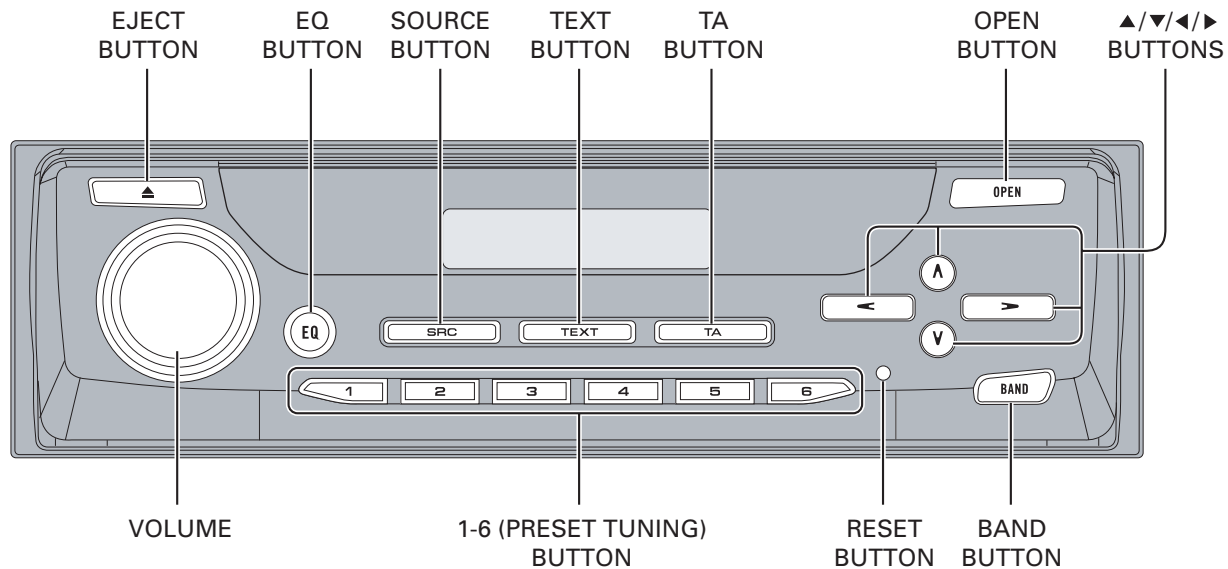

##### ● OPEN POSITION

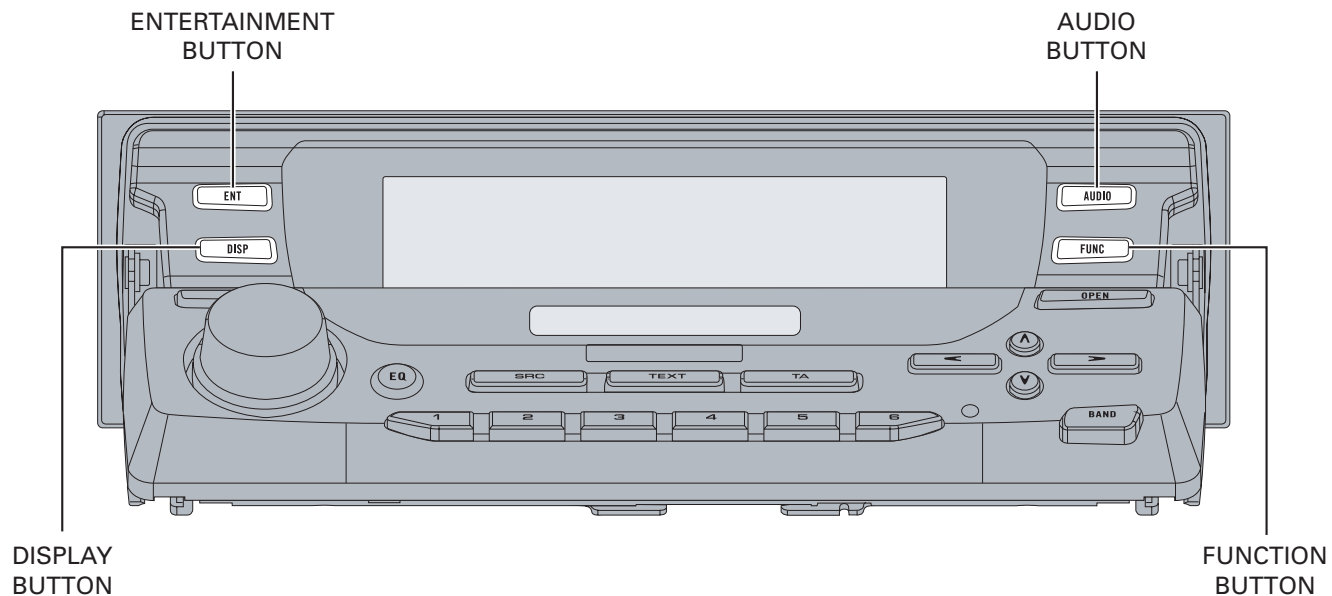

REMOTE CONTROL ASSY

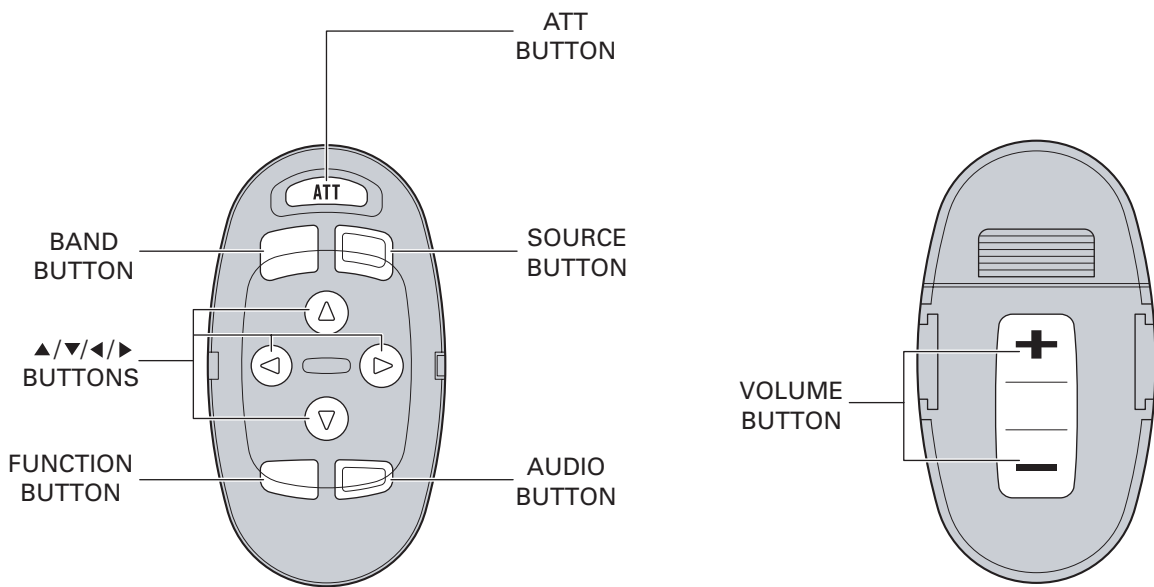

**CONNECTION DIAGRAM**

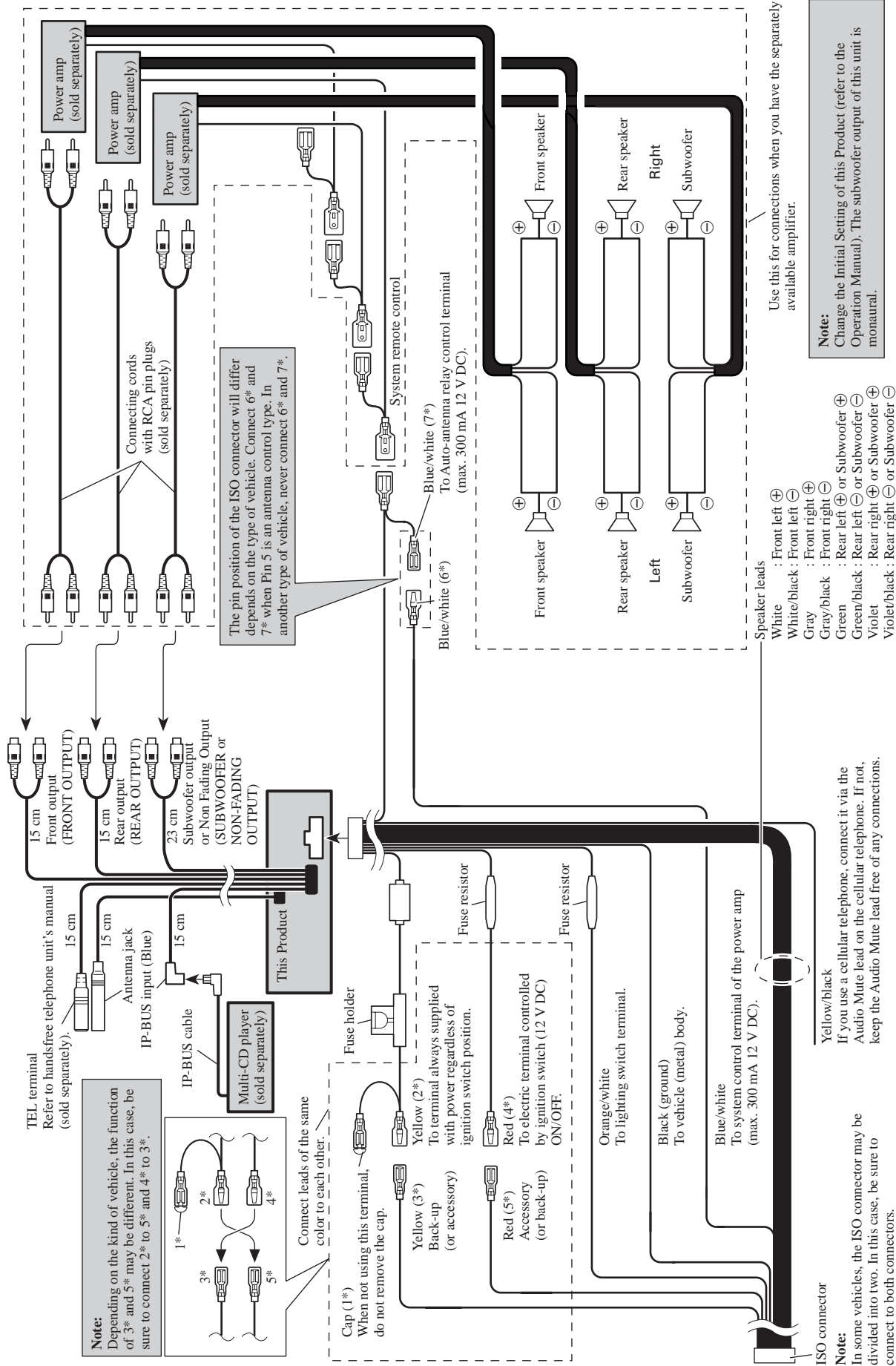



## 8.2 SPECIFICATIONS

### Specifications

#### General

Power source .....	14.4 V DC (10.8 – 15.1 V allowable)
Grounding system .....	Negative type
Max. current consumption .....	10.0 A
Backup current .....	5mA or less

#### Dimensions (W x H x D)

(When closed)	
Mouting size .....	178 x 50 x 157 mm
Nose .....	188 x 58 x 28 mm
(When opened)	
Mouting size .....	178 x 50 x 157 mm
Nose .....	188 x 68 x 50 mm
Weight .....	1.7 kg

#### Audio

Max. Power .....	50 W x 4 for Subwoofer (70 W x 1 ch/2 $\Omega$ ) 25 W x 4 (BRI)
Continuous power .....	27 W x 4 (DIN45324, +B=14.4 V)
Load impedance .....	4 $\Omega$ (4 – 8 $\Omega$ [2 $\Omega$ for 1 ch] allowable)
Preout max output level/output impedance .....	4.0 V/1 k $\Omega$
Equalizer (3band parametric equalizer):	
(Low)	
Frequency .....	40/80/100/160 Hz
Q Factor .....	0.35/0.59/0.95/1.15 (+6 dB when boosted)
Gain .....	$\pm 12$ dB
(Mid)	
Frequency .....	200/500/1k/2k Hz
Q Factor .....	0.35/0.59/0.95/1.15 (+6 dB when boosted)
Gain .....	$\pm 12$ dB
(High)	
Frequency .....	3.15k/8k/10k/12.5k Hz
Q Factor .....	0.35/0.59/0.95/1.15 (+6 dB when boosted)
Gain .....	$\pm 12$ dB
Loudness contour	
(Low) .....	
	+3.5 dB (100 Hz)
	+3 dB (10 kHz)
(Mid) .....	
	+10 dB (100 Hz)
	+6.5 dB (10 kHz)

(High) .....	+11 dB (100 Hz)
	+11 dB (10 kHz)
	(Volume : -30 dB)

#### Tone control

(Bass)	
Frequency .....	40/63/100/160 Hz
Gain .....	$\pm 12$ dB
(Treble)	
Frequency .....	2.5k/4k/6.3k/10k Hz
Gain .....	$\pm 12$ dB

#### HPF

Frequency .....	50/80/125 Hz
Slope .....	-12 dB/oct

#### SW

Frequency .....	50/80/125 Hz
Slope .....	-18 dB/oct
Gain .....	$\pm 12$ dB
Phase .....	Normal/Reverse

#### CD player

System .....	Compact disc audio system
Usable discs .....	Compact disc
Signal format:	
Sampling frequency .....	44.1 kHz
Number of quantization bits .....	16; linear
Frequency characteristics	
.....	5 – 20,000 Hz ( $\pm 1$ dB)
Signal-to-noise ratio .....	94 dB (1 kHz) (IEC-A network)
Dynamic Range .....	92 dB (1 kHz)
Number of channels .....	2 (stereo)
MP3 decoding format .....	MPEG-1&2 Audio Layer-3
WMA decoding format .....	Ver. 7 & 8

#### FM tuner

Frequency range .....	87.5 – 108 MHz
Usable sensitivity .....	9 dBf (0.8 $\mu$ V/75 $\Omega$ , mono, S/N:30 dB)
50 dB quieting sensitivity .....	15 dBf (1.5 $\mu$ V/75 $\Omega$ , mono)
Signal-to-noise ratio .....	70 dB (IEC-A network)
Distortion .....	0.3% (at 65 dBf, 1 kHz, stereo)
Frequency response .....	30 – 15,000 Hz ( $\pm 3$ dB)
Stereo separation .....	40 dB (at 65 dBf, 1 kHz)

#### MW

Frequency range .....	531 – 1,602 kHz (9 kHz)
Usable sensitivity .....	18 $\mu$ V (S/N: 20 dB)
Selectivity .....	50 dB ( $\pm 9$ kHz)

#### LW

Frequency range .....	153 – 281 kHz
Usable sensitivity .....	30 $\mu$ V (S/N: 20 dB)
Selectivity .....	50 dB ( $\pm 9$ kHz)



#### Note

- Specifications and the design are subject to possible modifications without notice due to improvements.