

Technical Service Manual

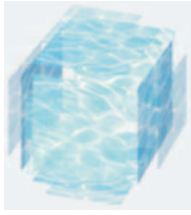

Dishwasher

Contents

Specification	2
Function Description	3-4
Water circuit	3-5
Theory of parts	6-24
Location	6
PCB	7-8
Inlet valve	9-11
Drain pump	12-13
Heater	14-15
Washing pump	16-17
Pressure switch	18
NTC	19-20
Flowmeter	21-22
Safety Hose	23-24
Diverter valve	25
Test program	26-30
Procedure	27
Error code	28-30
Inspection	31-34
Troubleshooting	35-39

SAFETY NOTICE

This documentation is only intended for qualified technicians who are aware of the respective safety regulations.

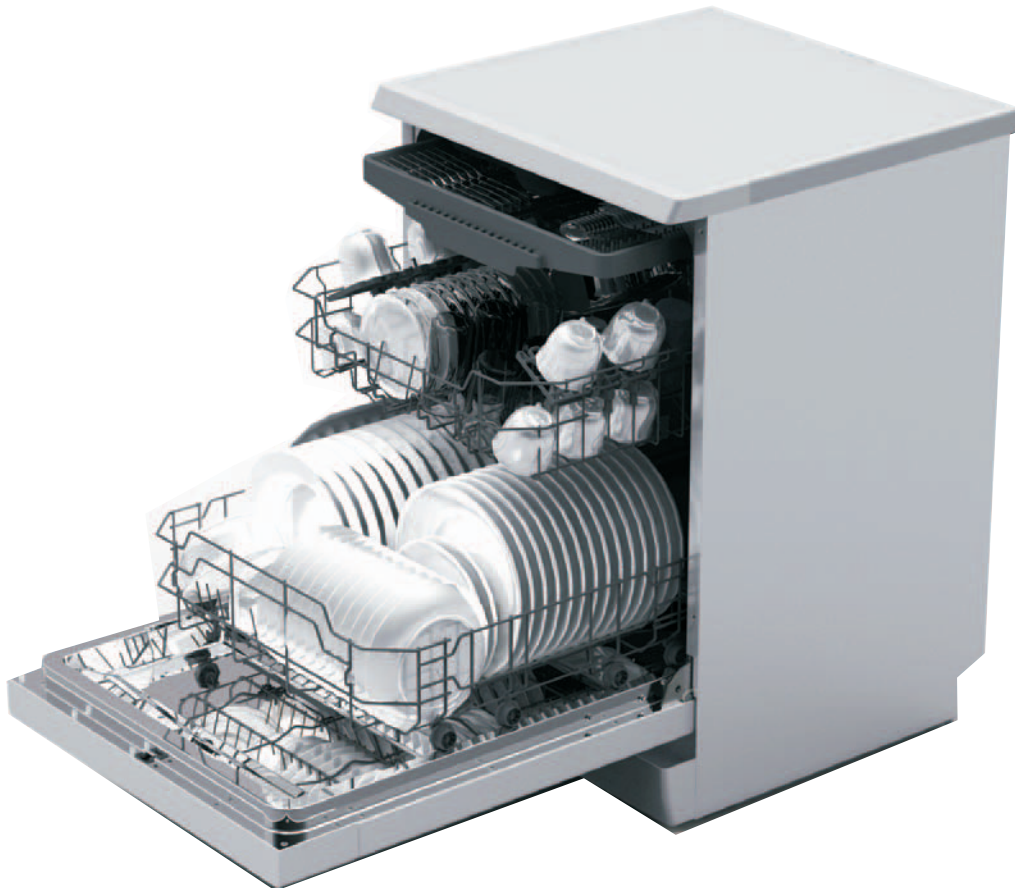

Electrical supply	220-240V, 50Hz
Supply water pressure	0.04MPa-1.0MPa
Supply water temperature	below 60°C

For the basic operation instructions, please refer to the instruction manual attached with each unit.

Note: This page is for models with common inlet hose.

Water circuit scheme

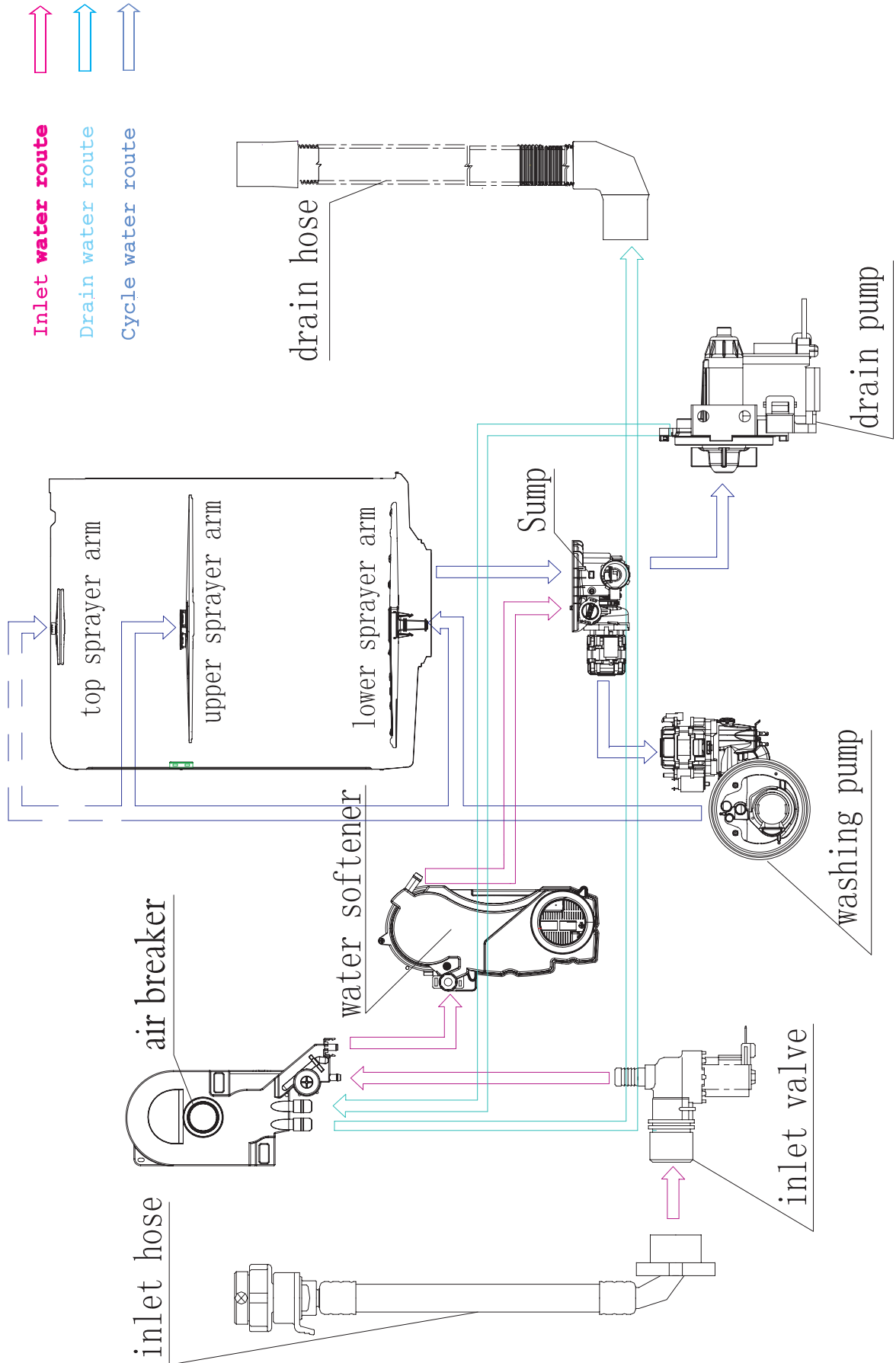

Note: This page is for models with aquastop hose.

Water circuit scheme

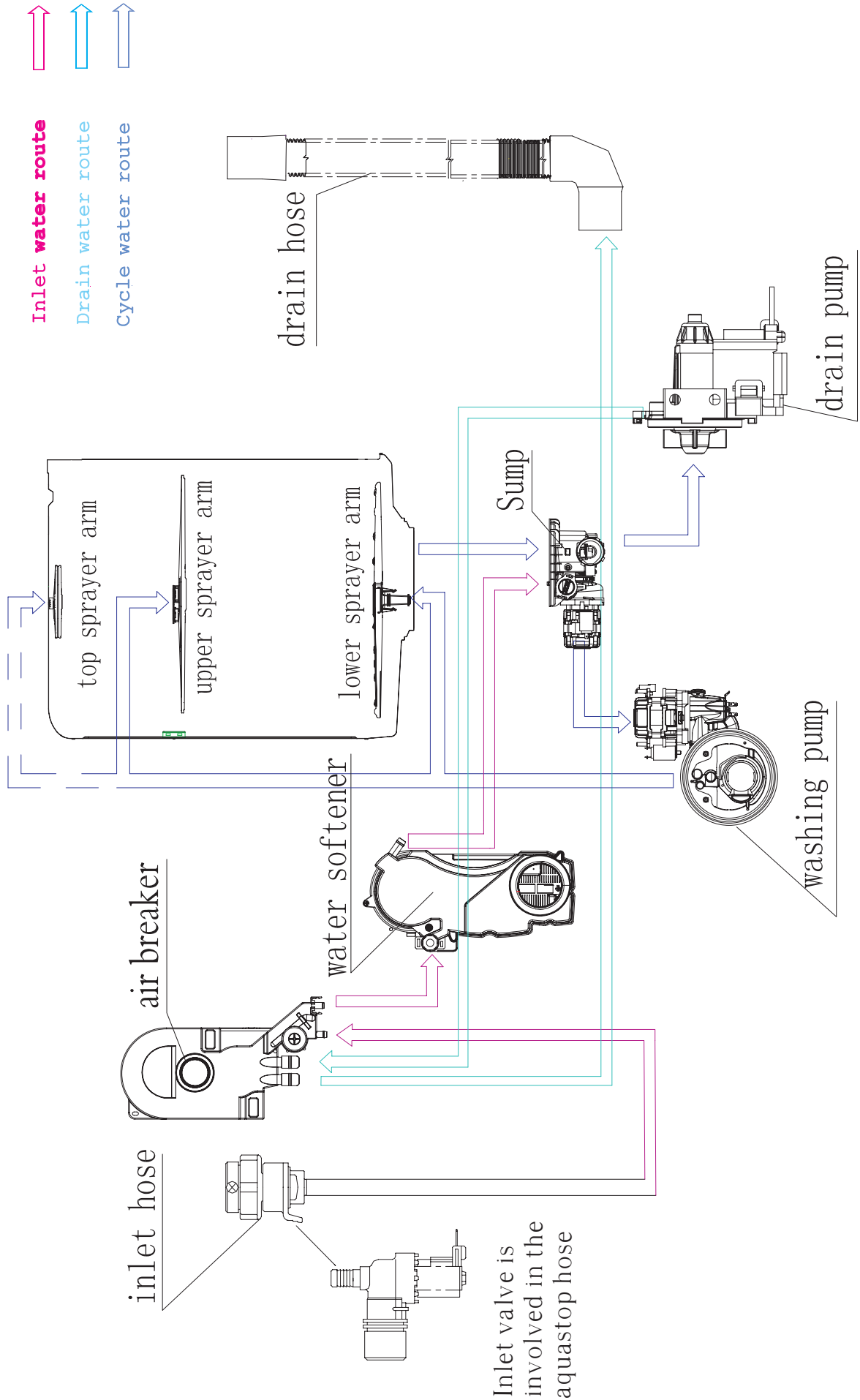

Process of water inlet (indicated by magenta route)

In this process, regeneration water route is cut off, main water route is open. The water in the main water route is softened when pass through the softener, and then enter in the tub. During this phase, some of inlet water will be stored in the air breaker to be regenerating water.

Process of cycle washing (indicated by blue route)

Cycle washing action is driven by washing pump motor. Water can obtain the power during it passing through the working washing pump, then be pumped into spray arm, pass from spray arm nozzles, over the dishes, into sump ,where connect to washing pump, and to get in the next water cycle.

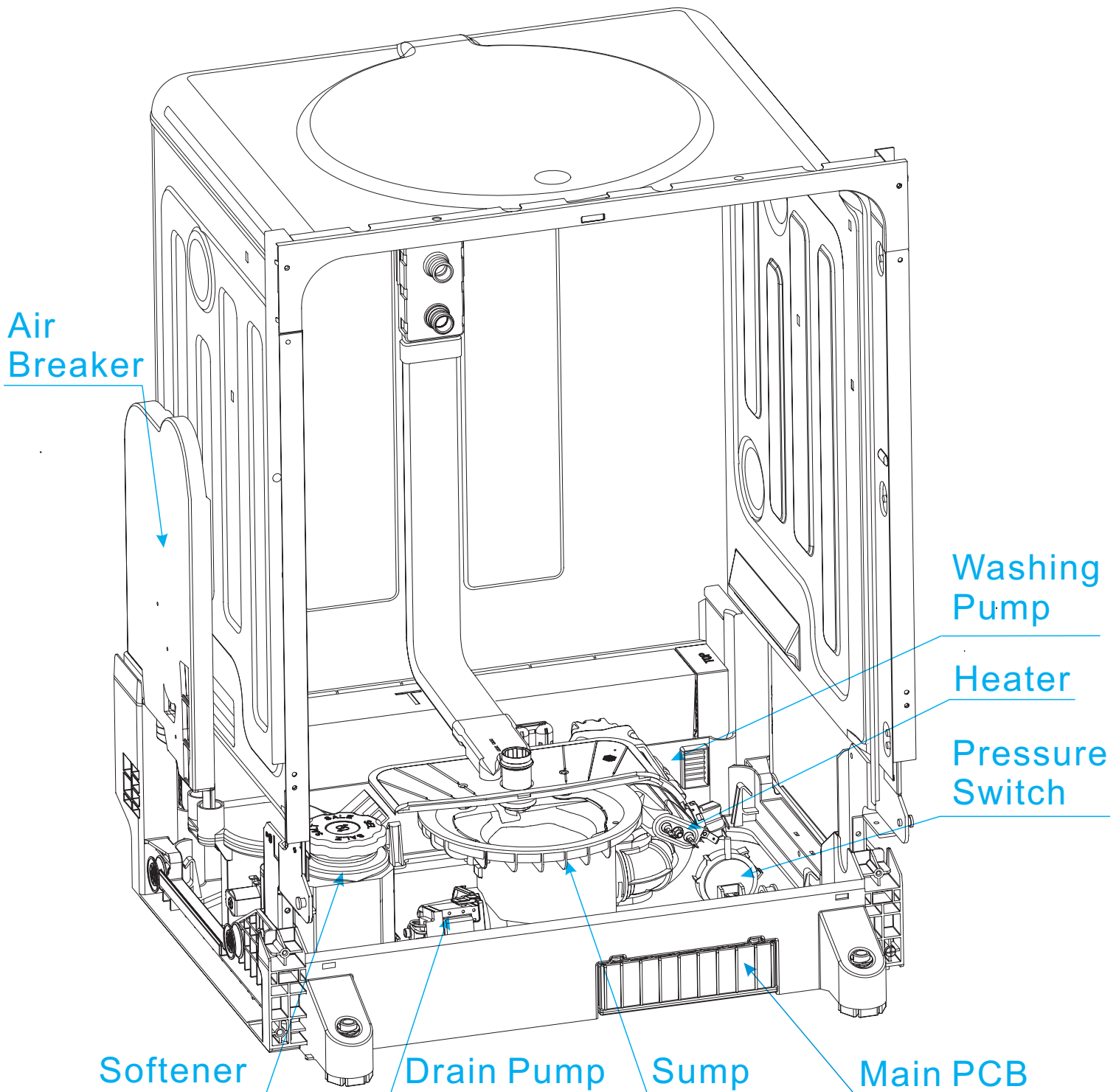

Please Note: Explode view and part list of each model have some different visions. So please refer to the newest vision Midea sent you

PCB

Printed Circuit Board is the control center of dishwasher, which receive and process signal from components, send order to components and deal with the feedback information, etc.

Access PCB

Removing the protecting box.

The PCB can be removed from the protecting box in the bottom of machine.

1. Disconnect power supply;
2. Take out cutlery basket, basket and filter system;
3. Remove the screws for fixing protecting box and open the protecting box cap;

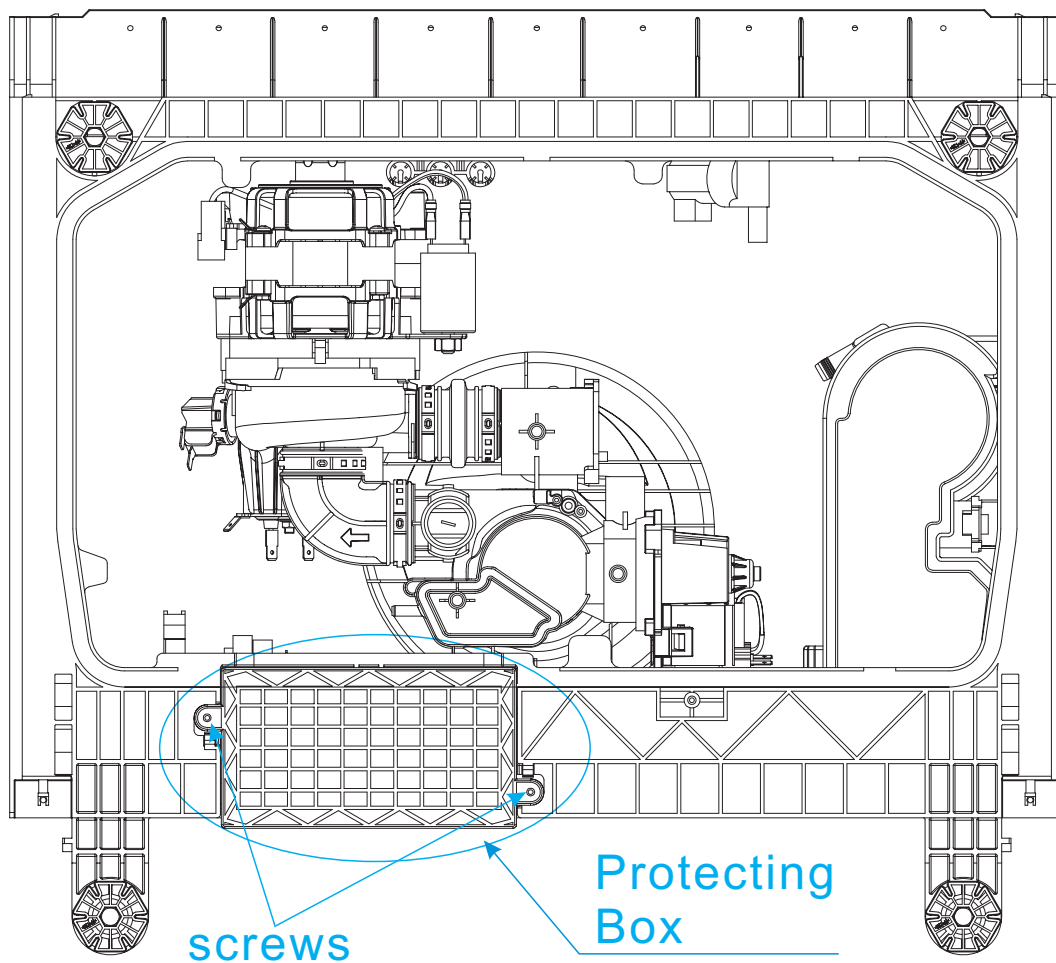

Bottom view

4. Remove the screws securing the PCB to protecting box;
5. Disconnect the connector form PCB;
6. Remove the PCB;
7. Reverse the above procedure to install.

View of PCB

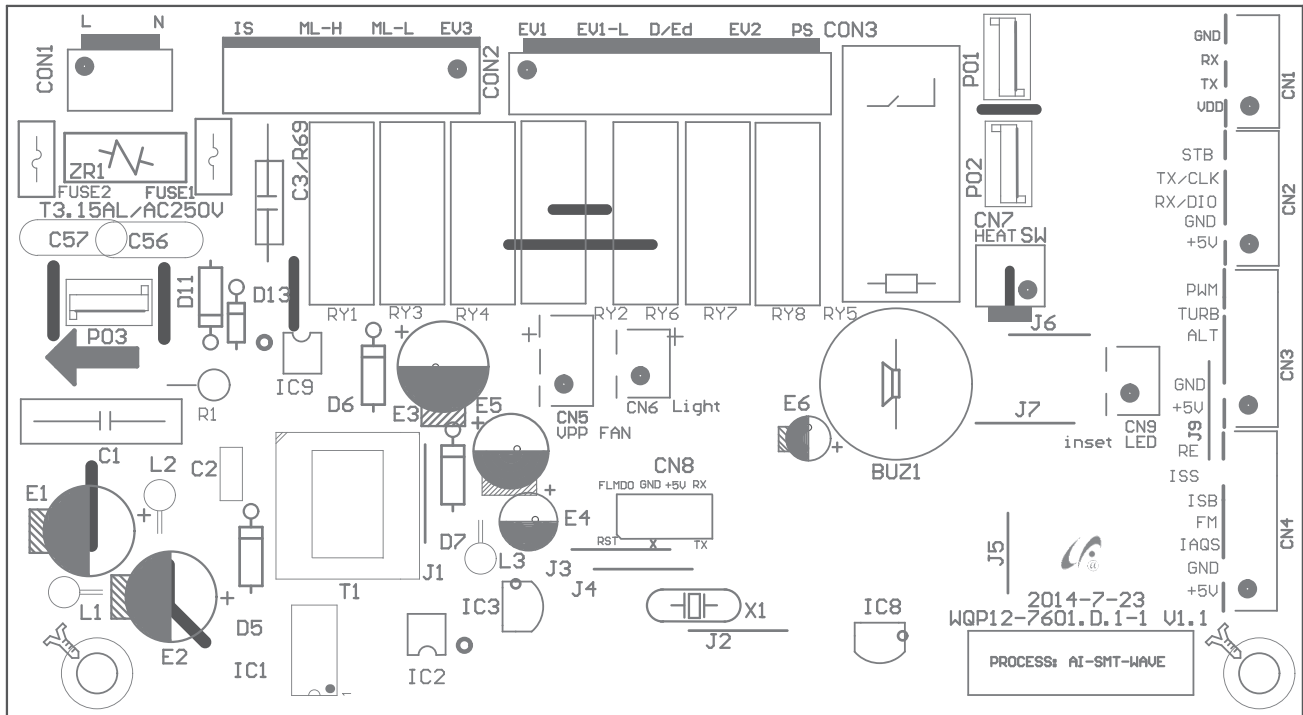

Note: This map is applies to 7601 model.

Description

NO.	Mark	Function
1	ML-H	Higher-speed Washing Pump
2	PS	Drain Pump
3	EV1	Inlet Valve
4	P01/P02	Heating Element
5	EV2	Regeneration Valve of Softener
6	EV3	Diverter Valve
7	ML-L	Lower-speed Washing Pump
8	D/Ed	Dispenser
9	FAN	Fan
10	BUZ1	Buzzer
11	LIGHT	Top light
12	RE	Thermister
13	IS	Door
14	IAQS	Overflow detect
15	ISS	Salt detect
16	ISB	Rinse detect
17	FM	Flowermeter
18	TURB	Turbidity detect

There is small pole's location difference between different models.
But the marks on PCB have the same meaning described on the left side.

Location of inlet valve

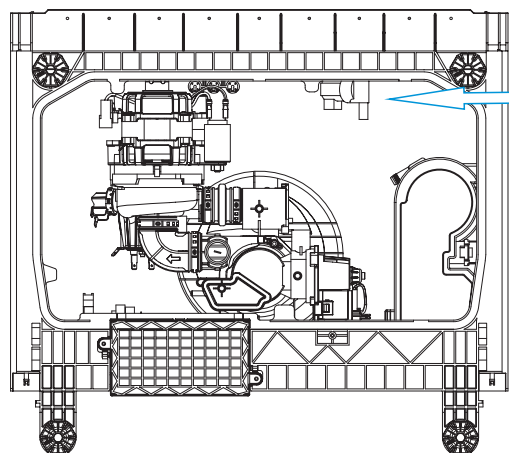

Bottom view

Appearance

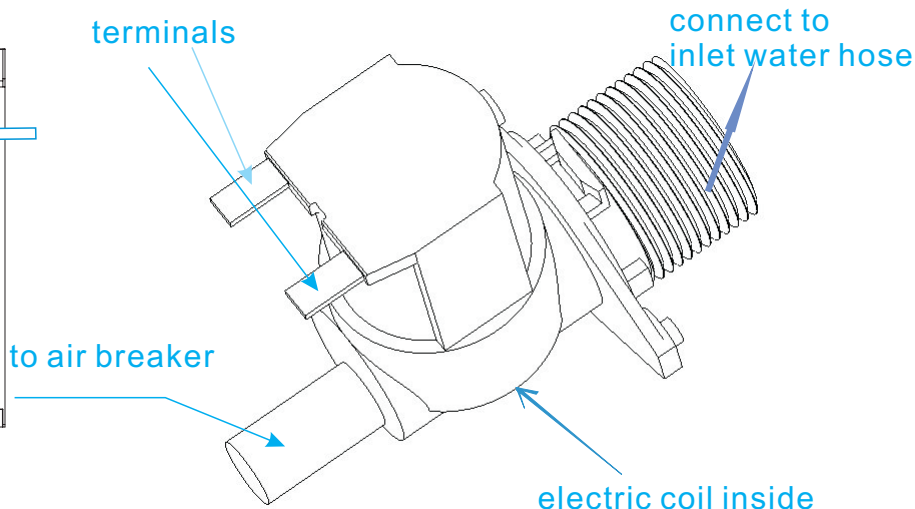

The work principle

The inlet valve is electromagnetic valve that decide whether water enter or not. Valves are normally closed. Each time the appliance requires water, the controller will convey an electric signal to the coils to open the valve.

The inlet valve consists of electric coil, valve body, valve pole, filter etc.

In a word, the electromagnetic valve can act to allow water enter into machine, when it receives the order given by controller.

The defeat point

1. The valve coil is broken, so the valve can't open. It will cause the E1 error.
2. The filter is jammed, so water can't enter. It will cause the E1 error.
3. The connector is loose, so the valve can't open. It will cause the E1 error.
4. The valve pole is rusted or locked by dreg, so the valve can't open or close. It will cause the E1 or E4 error.

Technical data

Nominal voltage	220-240VAC
Frequency	50/60Hz
Resistance	Approx:3.4 - 4.4kΩ
Work duty	100%ED T25 3min/5min T60
Flux	2.5L/min 15%
Power	5W
Work Pressure	MAX.Working Pressure 1MPa

Access inlet valve

1. Disconnect power.
2. Remove the water inlet hose. (Note : Be careful of remain water drop.)
3. Remove the cover of the bottom board.

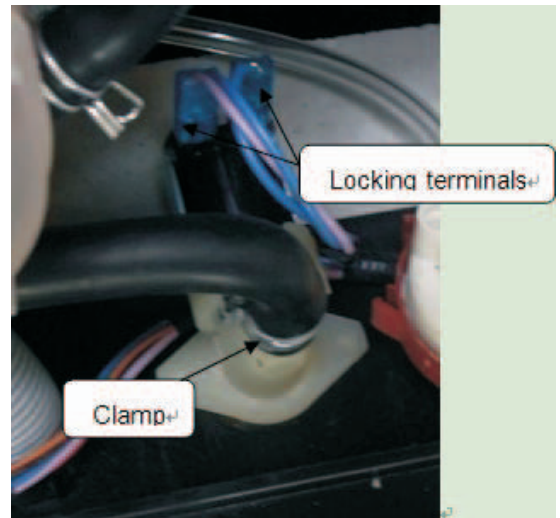
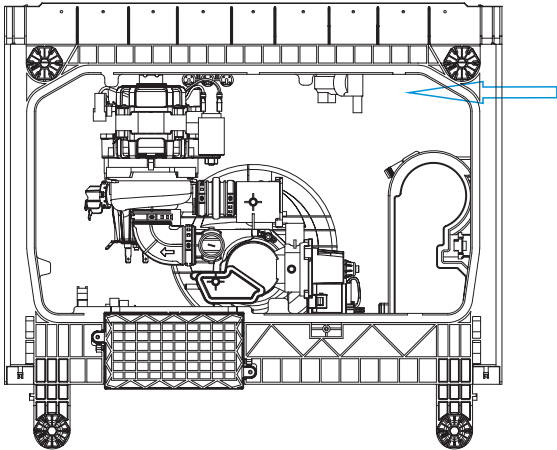

4. Disconnect the 2 terminal lugs from the inlet valve.
5. Pull out the valve a little then contrarotate it to take it off.
6. Remove the clamp and disconnect the inlet hose (to air breaker) from the water valve.
7. Reverse above procedures to install.

Inspect inlet valve

Check electric part

1. Open the protecting box and take out the PCB;
2. With the door closed, unplug the CON3 and ACN wires , then use the multi-meter Ω shelf to measure resistance between the blue wire (EV1) and the blue wire(ACN), the normal resistance is about 4.4K Ω to 4.8K Ω .
3. If the measured resistance is not correct, it means the valve coil is broken or the connector is loose. In this case, we should check the connection first. If the problem hasn't been solved by re-connection, we should replace the valve.
4. If the resistance is OK, we need to inspect the valve body.

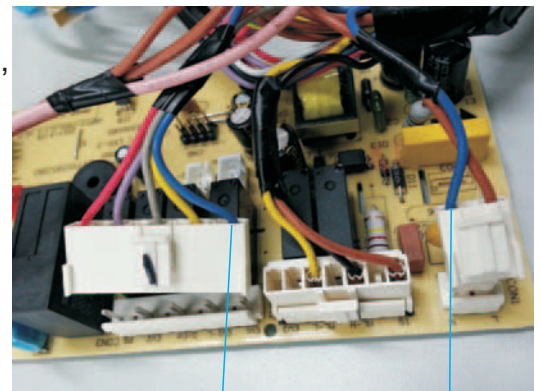

Check machine part

1. If the electric part is OK, we need to check the machine part.
2. Check the valve filter. if the valve filter is blocked, we need clear the residues.
3. If the valve filter is clear and the valve can't inlet water, check whether valve can act or not. If it isn't , we need replace the valve.
4. If the water is continue entering, we need replace the valve.

Location of Drain Pump

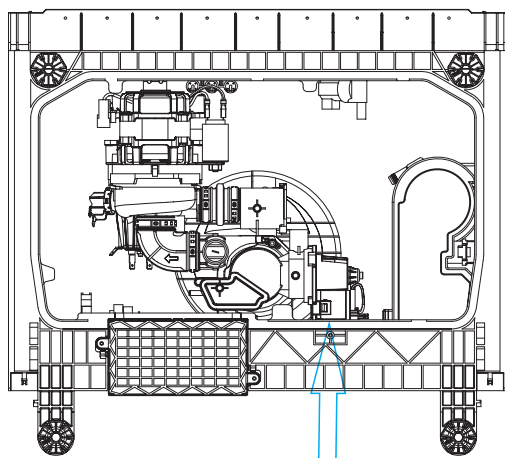

Bottom view

The work principle

Drain pump integrated into sump

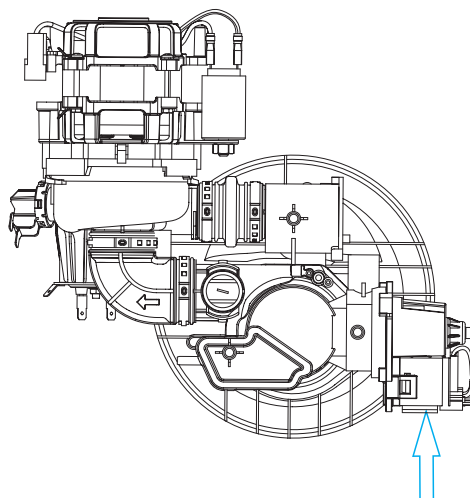

The work principle

Drain pump consists of electrical motor, impeller, inlet and outlet.

Drain pump is a kind of pump driven by permanent magnet synchronous motor. The rotor is made with permanent magnet material, the running inertia of rotor is very small, the stator consist of silicon steel stack and coil. When the drain pump is on power, the rotor will be very easy to start.

The defeat point

1. The motor coil is broken, so the drain pump can't work. It will cause the E1 error .
2. The magnetism of motor rotor is weak, so drain pump cannot work. It will cause the E1 error .
3. The connector is loose, so the drain pump can't work. It will cause the E1 error .
4. The rotor is locked by residues, so the drain can't work . It will cause the E1 error .
5. The drain pump assembly rack is loose, it will cause noise.
6. The non-return valve is bad, the remain water is too much.

Explanatory notes: failure of drain pump may cause E1, because if the water has not drained out, in next inflow process the pressure switch will act first to cut down the inlet valve, thus no water will get in and E1 error will occur.

Technical data

Nominal voltage	220-240VAC
Frequency	50Hz
Resistance	235Ω 15Ω
Delivery height	1M
Delivery performance	≥17l/min(230VAC)

Access drain pump

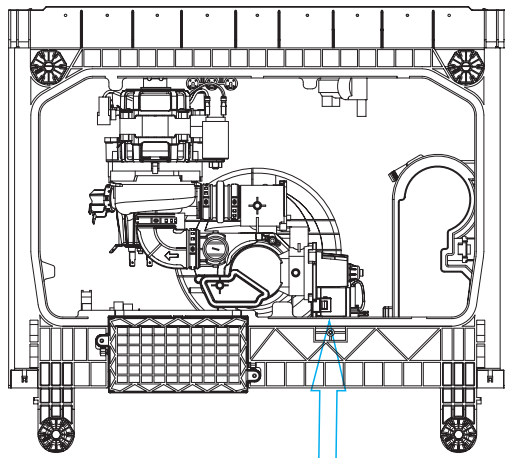

Bottom view

1. Drain off the water in the dishwasher, and disconnect the power supply.
(Note : Make sure to remove remained water in the dishwasher. If not, wet the floor.)
2. Remove the cover of the bottom board.
(Note:You should first loosen the top hooks, then the left and right hooks. And be care to do not break the hook.)
3. Label and disconnect the two terminal lugs from the drain pump.
4. Contrarotate the drain pump to take it off.
5. Reverse the above procedure to install.

Inspect drain pump

Check the electric part

1. Open the protecting box and take out the PCB;
2. With the door closed,unplug the CON3 and ACN wires, then use the multi-meter Ω shelf to measure the red wire (PS) and blue wire (ACN), the normal resistance is about 220Ω to 250Ω .
3. If the measured resistance is not correct, it means the pump coil is broken or connector is loose. In this case, we should check the connection first. If the problem hasn't been solved by re-connection, we should replace the drain pump.
4. If the resistance is OK, but it also can't work, maybe the magnetism is too weak, so we need to replace the drain pump.

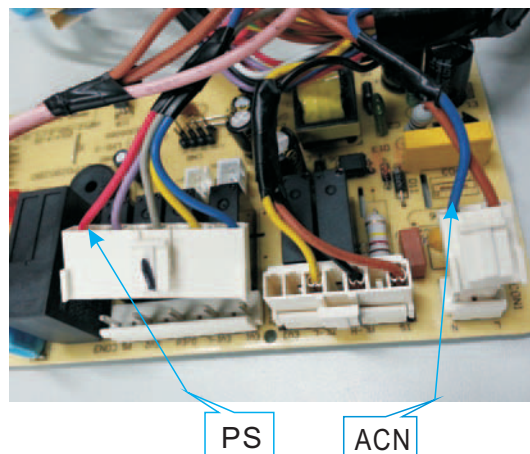

Check the machine part

1. If the electric part is OK, we need to check the machine part.
2. Remove bottom board.
3. If the non-return valve is wrongly assembled, the tub will remain much water. We need to re-assemble the non-return valve.
4. If the drain pump is working, but no water drain out or just a little. We should check the drain hose or drain body.

Location of Heater

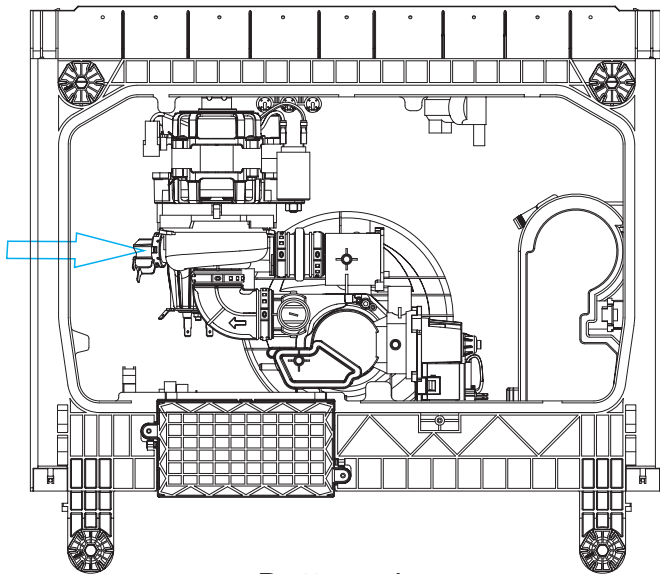

Bottom view

The work principle

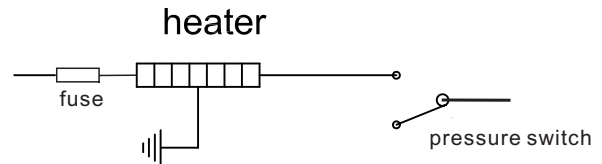

Technical data

Nominal voltage	220-240VAC
Rating power	1800W
Resistance	27.0-29.83Ω
Fuse	G5 184 C

The defeat point

1. The heater coil is broken, so the heater cannot work. It will cause the E3 error.
2. The Fuse is active, so the heater cannot work. It will cause the E3 error.
3. The connector is loose, so the heater cannot work. It will cause the E3 error.

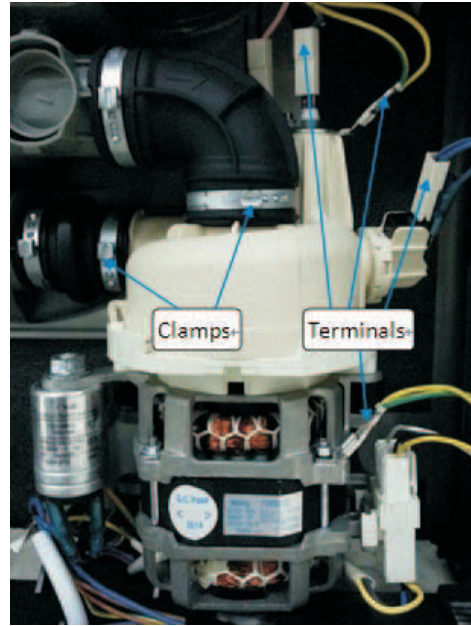
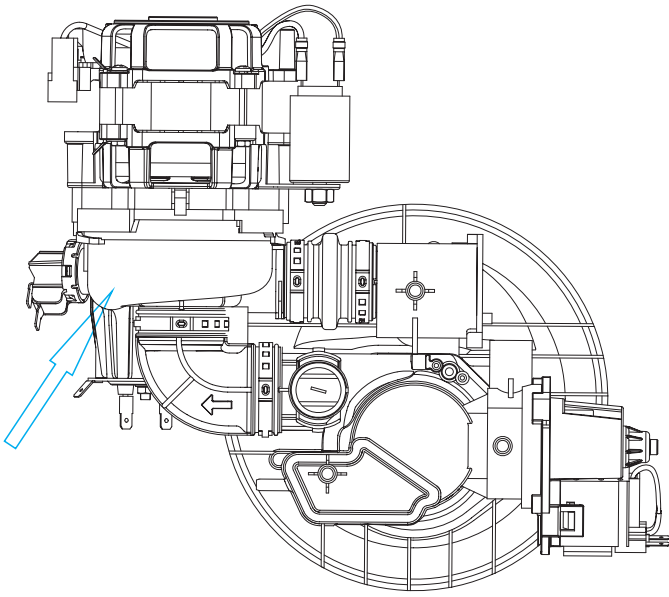

Access heater

1. Drain off the water in the dishwasher, and disconnect the power supply.
(Note : Make sure to remove remained water in the dishwasher. If not, wet the floor)
2. Remove bottom board.
3. Label and disconnect the terminals.
4. Remove the 2 clamps for fixing the pump hoses.
Caution: The clamp is easily damaged during removal and can't be reused. Replace the old clamp with a new universal clamp.
5. Contrarotate the upper pump to take it off.
6. Reverse above procedures to install.

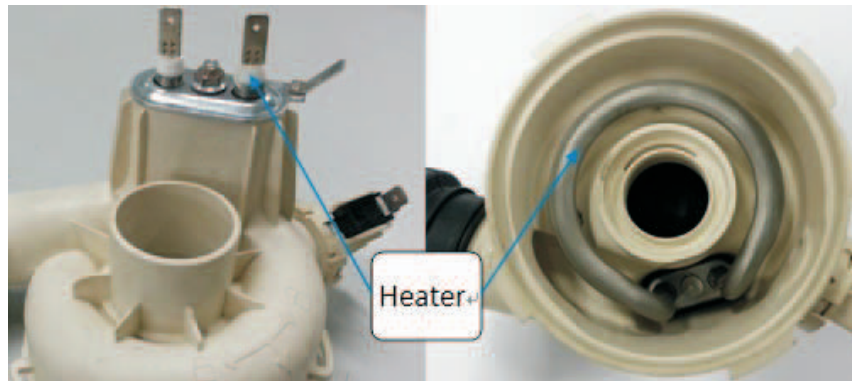

Inspect heater

1. Remove bottom board.
2. With the door closed, use the multi-meter Ω shelf to measure resistance between the two terminals shown in above right picture, the resistance is about 27Ω to 30Ω .
3. If the measured resistance is not correct, it means the heater coil or the thermostat is broken, we should replace the heating element or the thermostat.

Location of Washing Pump

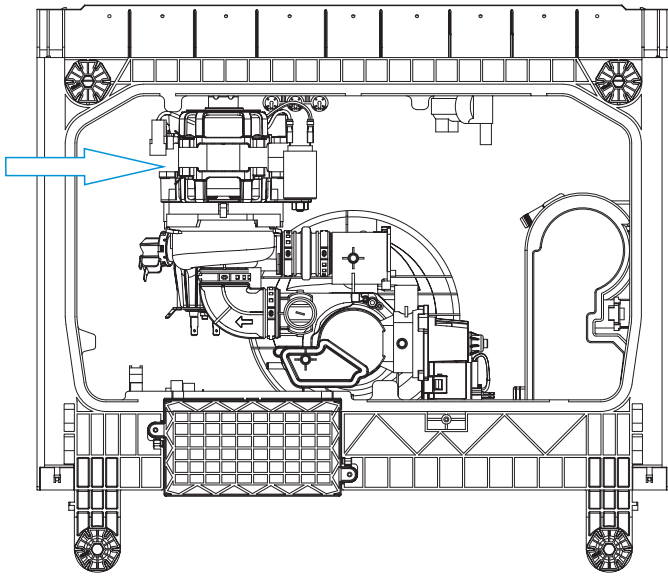

Bottom View

The work principle

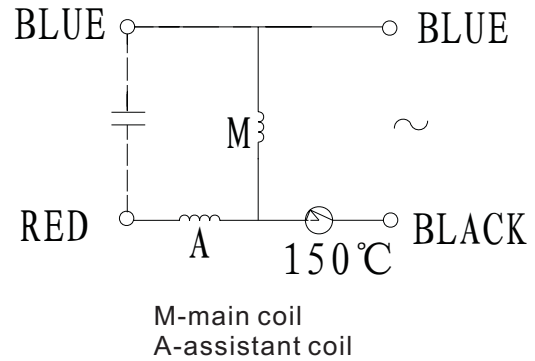

Washing pump is a kind of asynchronism motor with capacitor. The stator consist of silicon steel stack and two coils, main coil and assistant coil .

The defeat point

1. The motor coil is broken, so the wash pump can't work. It will cause E3 error.
2. The motor rotor capacitor is weaken, so washing pump can't start. In this case, it will send out the electromagnetism noise. If it is continue electrifying motor, the thermal protector will work. It will cause E3 error.
3. The connector is loose, the wash pump can't work. It will cause E3 error.
4. The rotor is locked by residues, so the wash pump can't work . It will cause the E3 error.
5. The drain pump assembly bracket is loose, it will cause noise.
6. If the machine hasn't been used for long time, there is a possibility the wash pump can't starting.

Technical data

Models	YXW50-2E
Items	
Nominal voltage	220-240VAC
Frequency	50Hz
Resistance	Main coil: 116.2 7%Ω Assistant: 101.5 7%Ω M1: 41.4 7%Ω
Delivery height	1.8m
Delivery performance	≥46l/min(235VAC)
Lock rotor current	0.44 15%(230VAC)
Operating current	0.96 10%(230VAC)
Capacitor	3μF 425V

Access Washing Pump

1. Disconnect power.
 2. Remove bottom board.
 3. Label and disconnect the terminals.
 4. Remove the 2 clamps for fixing the pump hoses.
- Caution: The clamp is easily damaged during removal and can't be reused. Replace the old clamp with a new universal clamp.
5. Contrarotate the upper pump to take it off.
 6. Remove the 1 screw foxing the impeller to the pump.
 7. Remove the 2 screws foxing the lower pump to the motor.
 8. Reverse above procedures to install.

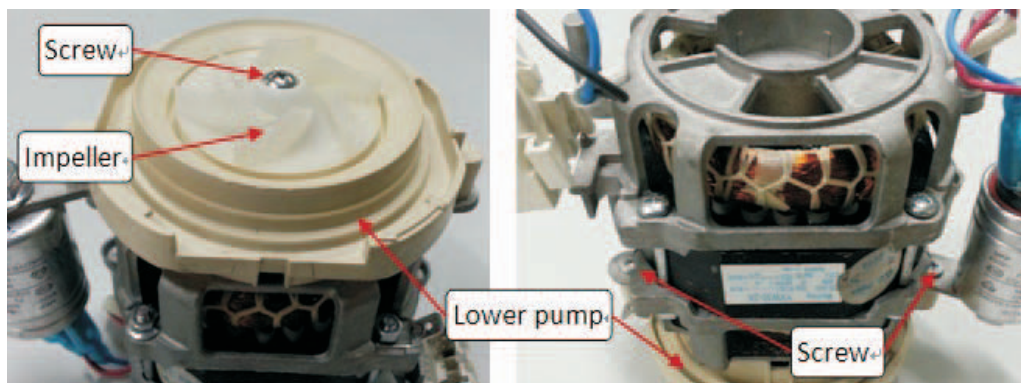

Inspect Washing Pump

Check the electric part

1. Open the control panel and take out PCB;
2. With the door closed, unplug the CON1 and CON2 , then use the multi-meter Ω shelf to test resistance between two wires (ML-H and ACN), the normal resistance is about 100Ω to 130Ω . And test resistance between two wires (ML-H and ML-L), the normal resistance is about 35Ω to 45Ω .
3. If any of the resistances is not correct, it means the pump coil is broken or the connector is loose, In this case, we should check the connection first. If the problem hasn't been solved by re-connection, we would replace the washing pump.
4. If the resistance is OK but it cannot work, it maybe the capacitor weakly, we need to replace the capacitor.

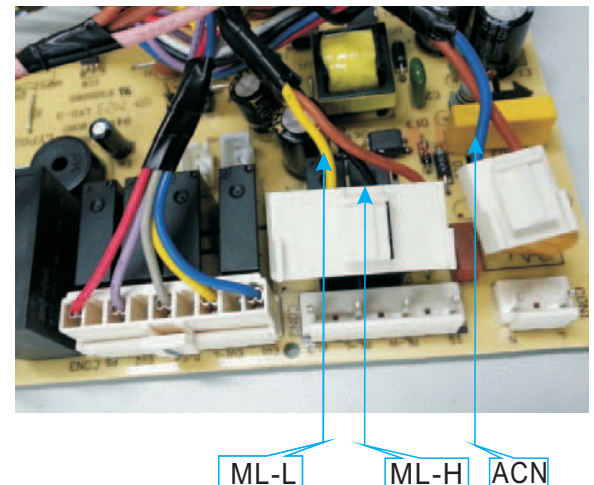

Check the machine part

1. If the electric part is OK, we need to check the machine part.
2. Remove bottom board.
3. Check the pump assembly, if the bracket is loose, it will bring the noise, we need to tighten it.
4. If the wash pump cannot start and the machine hasn't been used too long, maybe the seal element is bond.
5. If the drain pump is working, but no water out or just a little. We should check the vane wheel.

The work principle

The pressure switch consists of a moving diaphragm and disc which activate a change over contact. The contact can be calibrated to trip and reset at the desired pressure levels, The main application is to control the level of water in appliances. May also provide flood protection.

In our production, May also provide flood protection, like 135/115 serial.

1 - COM

2 - NC

3 - NO

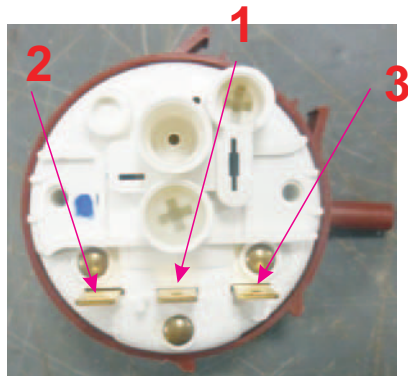

Front view



Back view

Location of NTC

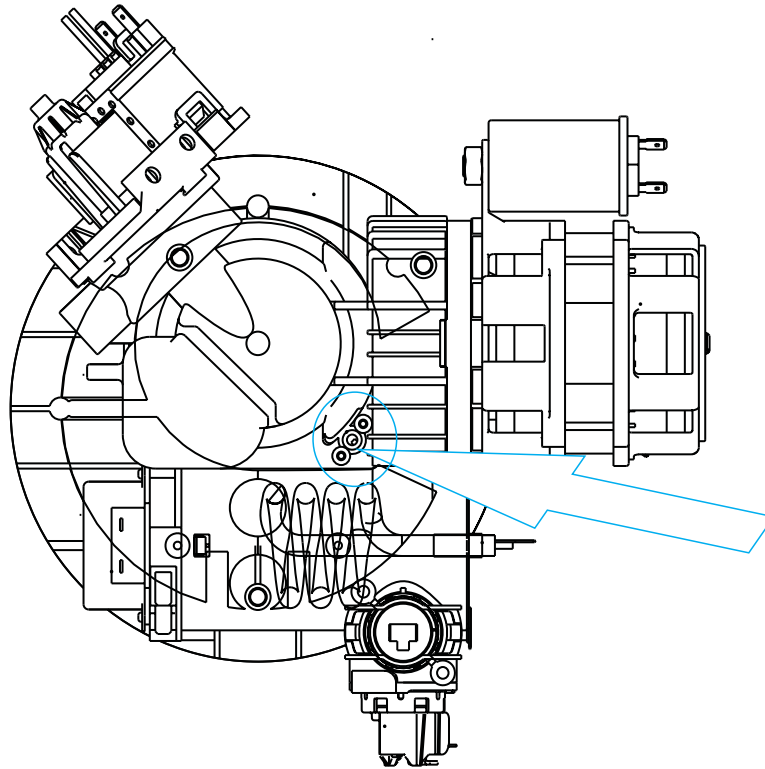

The work principle

Negative Temperature Coefficient Thermistor is integrated into sump, which is used for measuring temperature of water in the tub.

Access NTC

1. Remove bottom board.
2. Remove two screws securing the NTC to sump(shown in above picture).
3. Take out NTC.
4. Reverse the above procedure to install.

Inspect NTC

1. Open the protecting box and take out PCB;
2. With the door closed, unplug the RE connector (shown in below picture), then use the multi-meter Ω shelf to test resistance between two blue wires (RE and GND), the normal resistance is shown in below table.
3. If the resistance is not correct, it means NTC circuit has a problem. In this case, we should check the connection first. If the problem hasn't been solved by re-connection, we would replace the NTC.

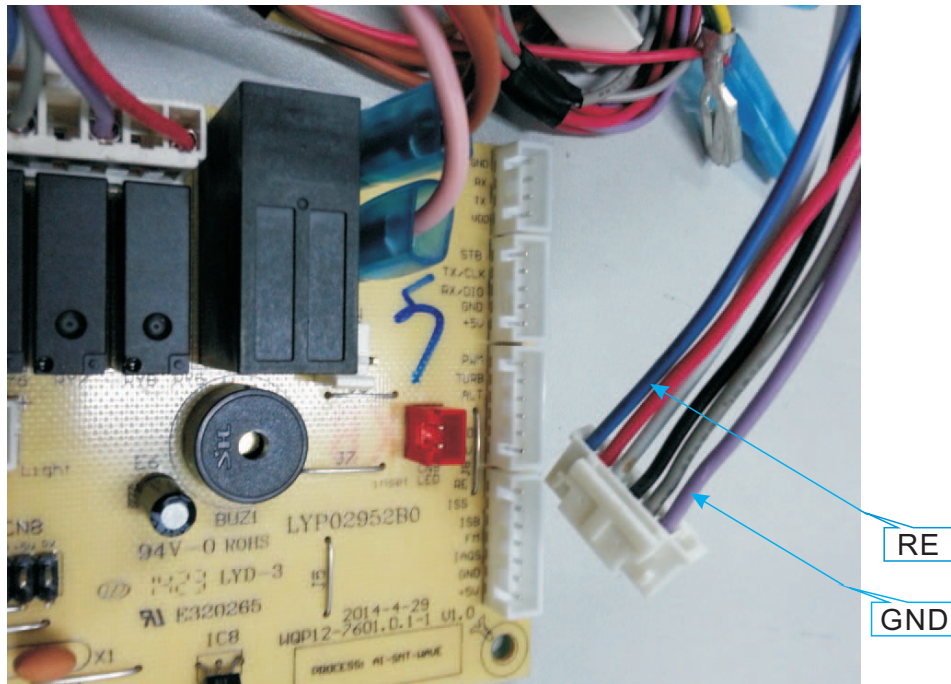

NTC resistance table

NTC	15°C	17.48K Ω
	20°C	12.12K Ω
	25°C	10K Ω
	30°C	8.299K Ω
	40°C	5.807K Ω
	50°C	4.144K Ω
	60°C	3.011K Ω
	70°C	2.224K Ω
	80°C	1.667K Ω
	85°C	1.451K Ω

Location of Flowmeter

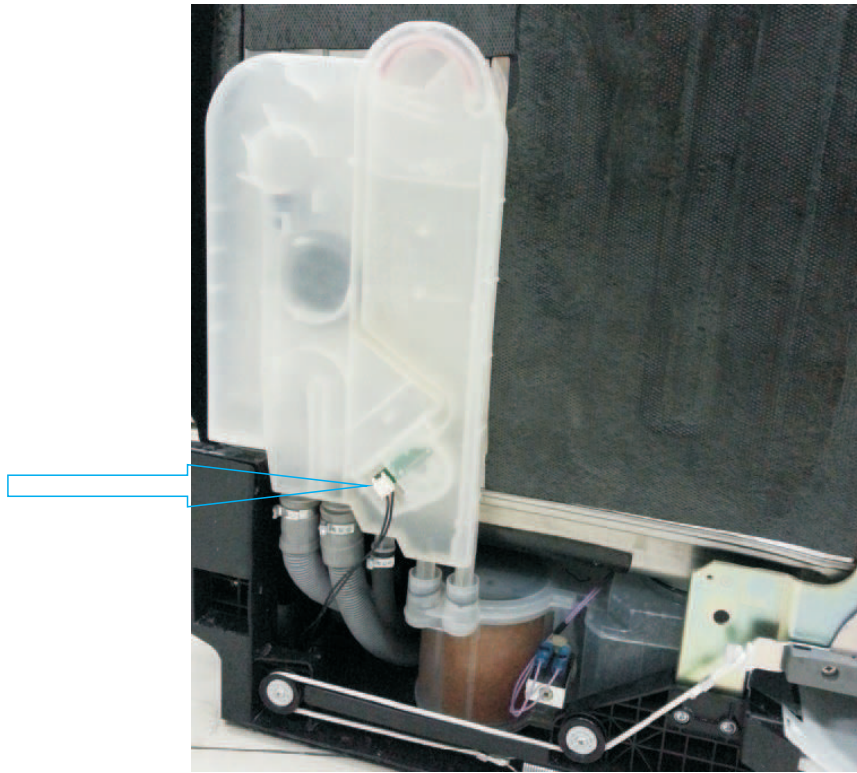

The work principle

Flowmeter is integrated into Air Breaker. Function of Flowmeter is measure how much water has entered in appliance. it consists of impeller, tongue tube and terminal, etc.

When water pass through the flowmeter, moving water can rotate magnetic impeller, the tongue tube can sense the impeller's magnetic and send electronic pulses.



Flowmeter

Access Flowmeter

1. Remove the baseboard, top panel and left side panel.
2. Remove the plastic nut inside tub, which secures the air breaker to tub. (Because flowmeter is integrated into air breaker, replace air breaker if flowmeter has failure.)
3. Disconnect the wire and remove clamp fastening hose to air breaker.
4. Take out air breaker.
5. Reverse the above procedure to install.

Inspect Flowmeter

1. Open the protecting box and take out PCB;
2. With the door closed, unplug the CON2 wire (shown in below picture), then use the multi-meter Diode shelf to test between black wire (FM) and blue wire (GND) to confirm whether electrical pulse is sent out while water is passing through flowmeter, or not.
3. If there is continual electrical pulse, the multi-meter will send out sound "de" continually.
4. If there is no electrical pulse, the multi-meter will not send sound. In this case, it means something wrong with flowmeter circuit. We should check the connection first. If the problem hasn't been solved by re-connection, we should replace the air breaker..

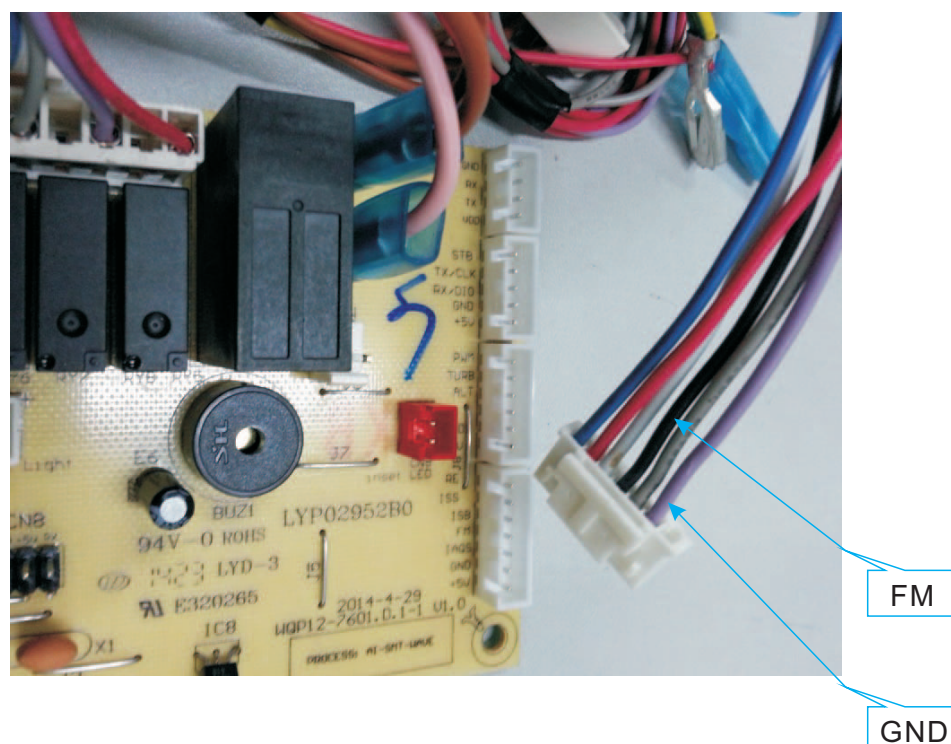

Location of Safety Hose

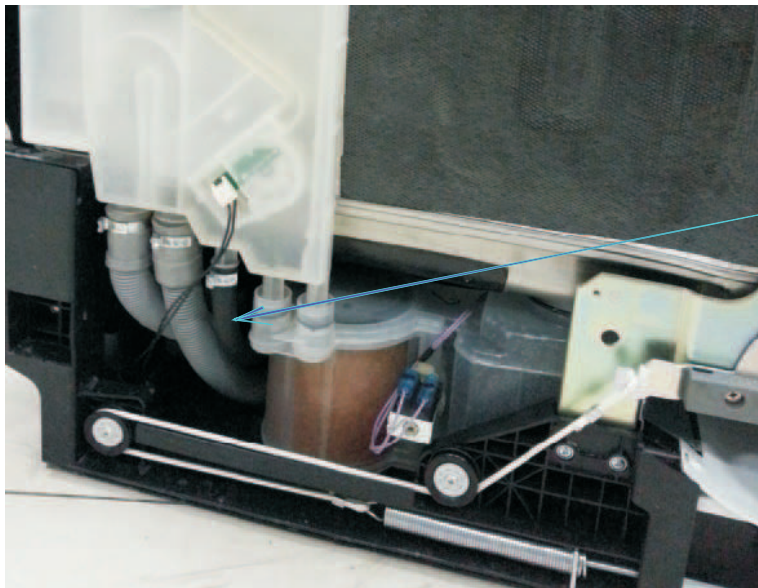

Electronic Aquastop Hose

The work principle

Mechanical Aquastop Hose

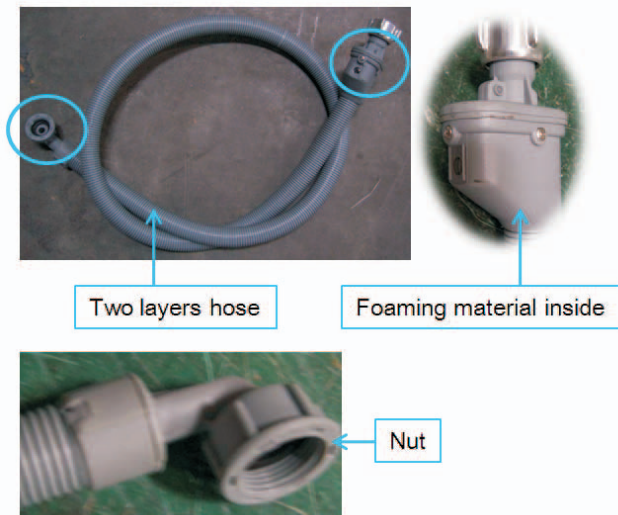

Electronic Aquastop Hose

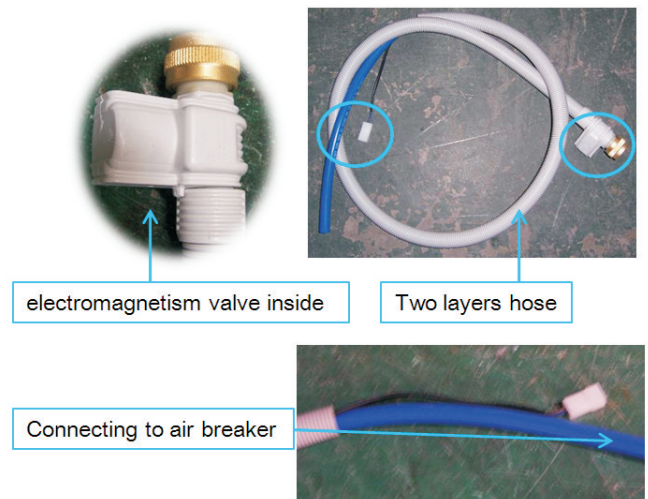

There are two types of Safety Hose, mechanical Aquastop hose and electronic Aquastop hose, which have different principles and assembly modes.

Mechanical Aquastop safety hose has two layers. If water leak and fill the air space between two layers, the foaming material will expand and lock the hose. In this situation, the machine might set off E1 alarm.

Electronic Aquastop safety hose also has two layers. But the difference from mechanical is that if the water leak and flow on the bottom tray, the flooding pressure switch on the tray will act, the electromagnetic valve on the hose will cut off the water road and the machine will set off E4 alarm.

Access Safety Hose

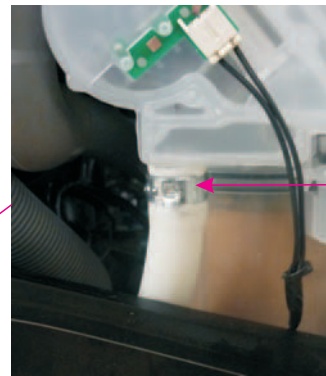
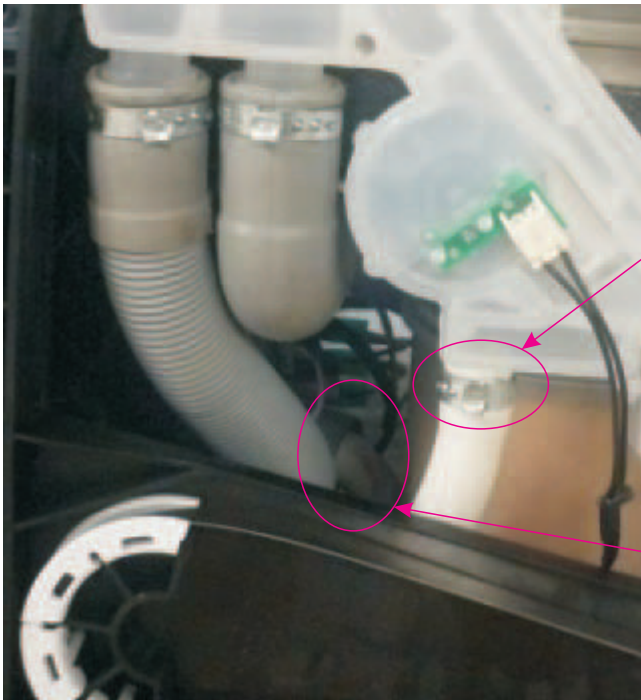

clamp

wire connector
(no need to distinguish
positive and negative electrode)

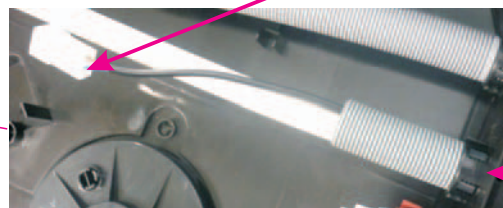

clamp ring

1. Remove baseboard, side baseboard, top panel and left side panel.
2. Remove clamp, cut the bound belt and disconnect the wire connector. Then the Inlet hose can be pulled out.
3. Reverse the above procedure to assemble.

Mechanical Aquastop Hose

Mechanical Aquastop hose is connected to appliance just as universal water inlet hose.

Inspect Safety Hose

Electronic Aquastop Hose

1. Open the protecting box and take out the PCB;
2. With the door closed, unplug the CON3 and ACN wires, then use the multi-meter Ω shelf to measure resistance between the blue wire (EV1) and blue wire (ACN). Open circuit and short circuit are both incorrect.
3. If the measured resistance is not correct, it means the valve coil is broken or the connector is loose. In this case, we should check the connection first. If the problem hasn't been solved by re-connection, we should replace the safety hose.

Mechanical Aquastop Hose

Maybe moisture absorption of foaming material in mechanical device cause a self-lock fault (can't fill the water) and this lock is non-resettable.

The work principle

Diverter, also named alternating flow control valve, is used to control the flow of water between the upper and lower spray arms and can also be used on some models to stop the flow of water to the upper spray arm on models equipped with a half load feature.

Hydraulic scheme

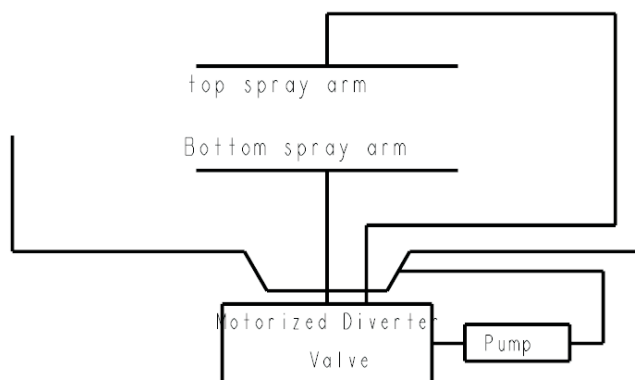

Access Diverter valve

1. Disconnect power.
2. Remove bottom board.
3. Label and disconnect the 4 terminals.
4. Remove 1 screw fastening the diverter valve to sump.
5. Contrarotate the diverter valve to take it off.
6. Reverse the above procedure to install.

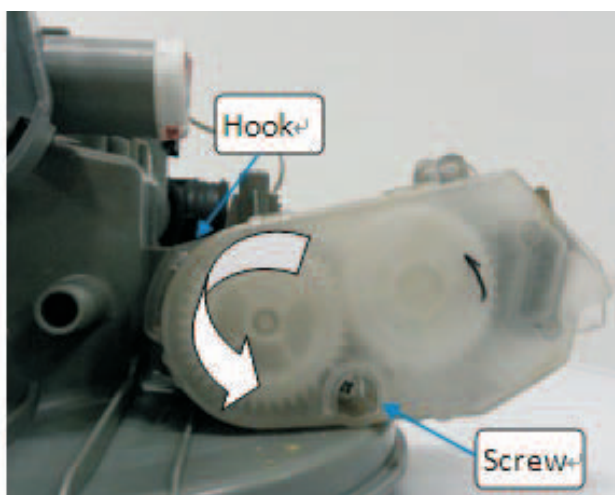
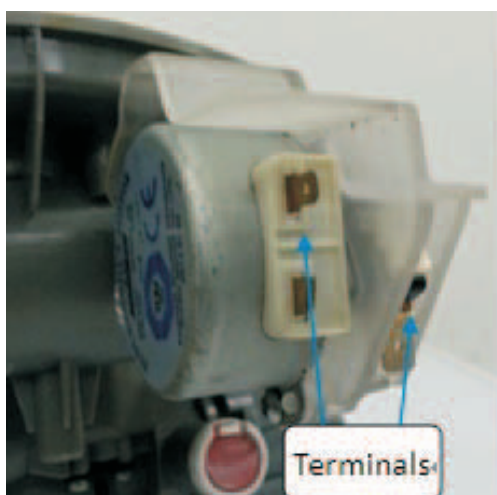
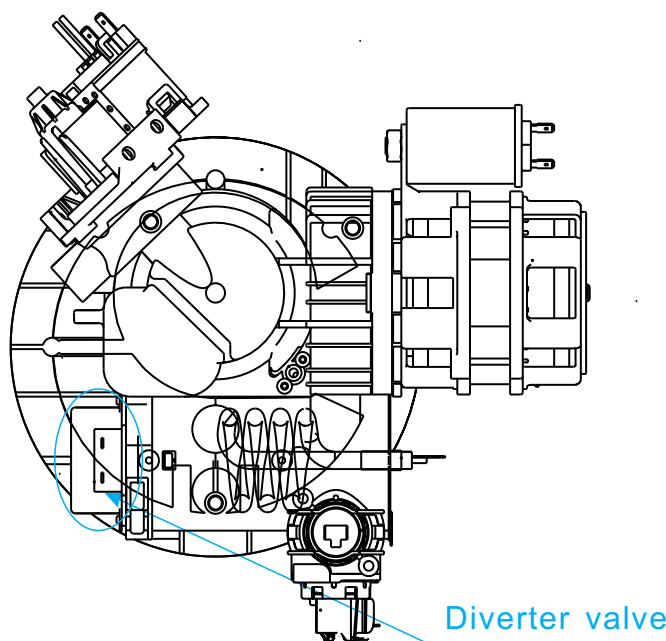

Note: This page is only for models with diverter value.

Test Program

In order to check the operation of components of appliance and find out the malfunction, we designed this program for technician.

How to activate Test Program

Test Program Operation	
How to activate Test Program	With door opened, Start/Pause + Power
Start Test Program	Close the door
Jump into next step	Start/Pause
E1	E1
E2	/
E3	E3
E4	E4
E6	E6
E7	E7
E8	E8

To activate test program, with the door opened and within 60s after power on, hold down the Program button and press the POWER button until the machine enter into Test Program. The appliance will pause and stand by(as step 00). Then close the door to start the Test Program.

During test program running, you can press Program button to jump into next step (except inlet valve step).

Note: 1. The way to activate test program is slightly different between different models.
2. Switch off the unit from the wall, then switch on before following the instructions above to activate the test cycle.

Procedure of Test Program (for models controlling water filling by flowmeter)			
No.	Display on the screen	Process	Description
0	8:88	Intialization	Power on, stand by
1	05 or Turbidity value	Inlet Valve	Open inlet valve and feeds with 3.6L water(45cm model feeds with 3.0L water). If the model is equipped with diverter, the diverter would move to positon rotating both upper and lower sprayarms. If the model is equipped with turbidity senser, turbidity value would be adjusted and shown on the screen.
2	04/Temperature value	Higher-speed Washing Pump and Heating Element	Run higher-speed washing pump and 10s later run heating element until the water temperature reaches 57°C. Then the machine will pause. Press Start/Pause button to jump into the next step.
3	03	Lower-speed Washing Pump and Dispenser	2s later run lower-speed washing pump for 8s, dispenser will act for 45s in this step.
4	02	Regeneration Valve	Open regeneration valve for 30s.
5	01	Drain Pump	Drain for 30s.
6	F*	finish	Buzz one sound, stop, and stand by.

How to know which error code has occurred

To know which error code has occurred, refer to the previous table named Test Program Operation.

Take E1 for example, If the error 1 has happened, the buzzer would alarm for 30 seconds and “E1” would be shown on display. Other error alarms would be shown in the same manner.

The corresponding relation between indicator combination and error code shown in above figure.

Notice: the majority of models are follow this regulation.

Attention

Priority level of E4 is the highest. E4 operation is valid after other error operations have done. When E4 operation has done, all the others are invalid.

In test program, E1, E3, E4, E6, E7 and E8 are valid.

Note: E8 is valid for models equipped with diverter valve(alternative washing function).

How does the appliance react when error code occurred

E1 Water filling exceed pre-set time

If the inlet valve has been opened for 4 minutes but the water quantity hasn't reached the desired value(measure by pluses), E1 would occur.

When E1 occurs, the drain pump will run until flowmeter keep motionless for 2 minutes and all the other components will be stopped immediately. At the same time, the buzzer will alarm for 30 seconds and error 1 will be shown.

E3 Heating exceed pre-set time

If the heating element has been working for 60 minutes but the water temperature detected by NTC hasn't reached desired value. E3 would occur.

When E3 occurs, the drain pump will run until flowmeter keep motionless for 2 minutes. and all the other components will be stopped immediately. At the same time, the buzzer will alarm for 30 seconds and the error 3 will be shown.

E4 Overflow

At any time, if overflow micro-switch act and keep for longer than 2 seconds, the E4 would occur. When E4 occurs, the drain pump will run until flowmeter keep motionless for 2 minutes . and all the other components will be stopped immediately.

At the same time, the buzzer will alarm for 30 seconds and error 4 will be shown.

Note: Priority level of E4 is the highest. E4 operation is valid after other error operations have done. When E4 operation has done, all the others are invalid.

E6 Open-circuit failure of thermistor

In test program, once open-circuit failure of thermistor is detected by controller, the E6 would occur. When E6 occurs, the drain pump will run until flowmeter keep motionless for 2 minutes. and all the other components will be stopped immediately.

At the same time, the buzzer will alarm for 30 seconds and error 6 will be shown.

E7 Short-circuit failure of thermistor

In test program, once short-circuit failure of thermistor is detected by controller, the E7 would occur. When E7 occurs, the drain pump will run until flowmeter keep motionless for 2 minutes . and all the other components will be stopped immediately. At the same time, the buzzer will alarm for 30 seconds and error 7 will be shown.

E8 Diverter valve fault

For models equipped with diverter(alternative washing function)

In the process of test program in which diverter valve should be act, if machine doesn't detect the feeding signal of diverter valve for 15 seconds or doesn't detect the diverter valve being positioned accurately in 60 seconds, the E8 would occur.

In the process of washing program in which diverter valve should be act, if machine doesn't detect the feeding signal of diverter valve for 15 seconds or doesn't detect the diverter valve being positioned accurately in 60 seconds, the diverter valve would stop and the E8 would be set off after ending washing program.

When E8 occurs, the drain pump will run until flowmeter keep motionless for 2 minutes and all the other components will be stopped immediately. At the same time, the buzzer will alarm for 30 seconds and the error code will be shown.

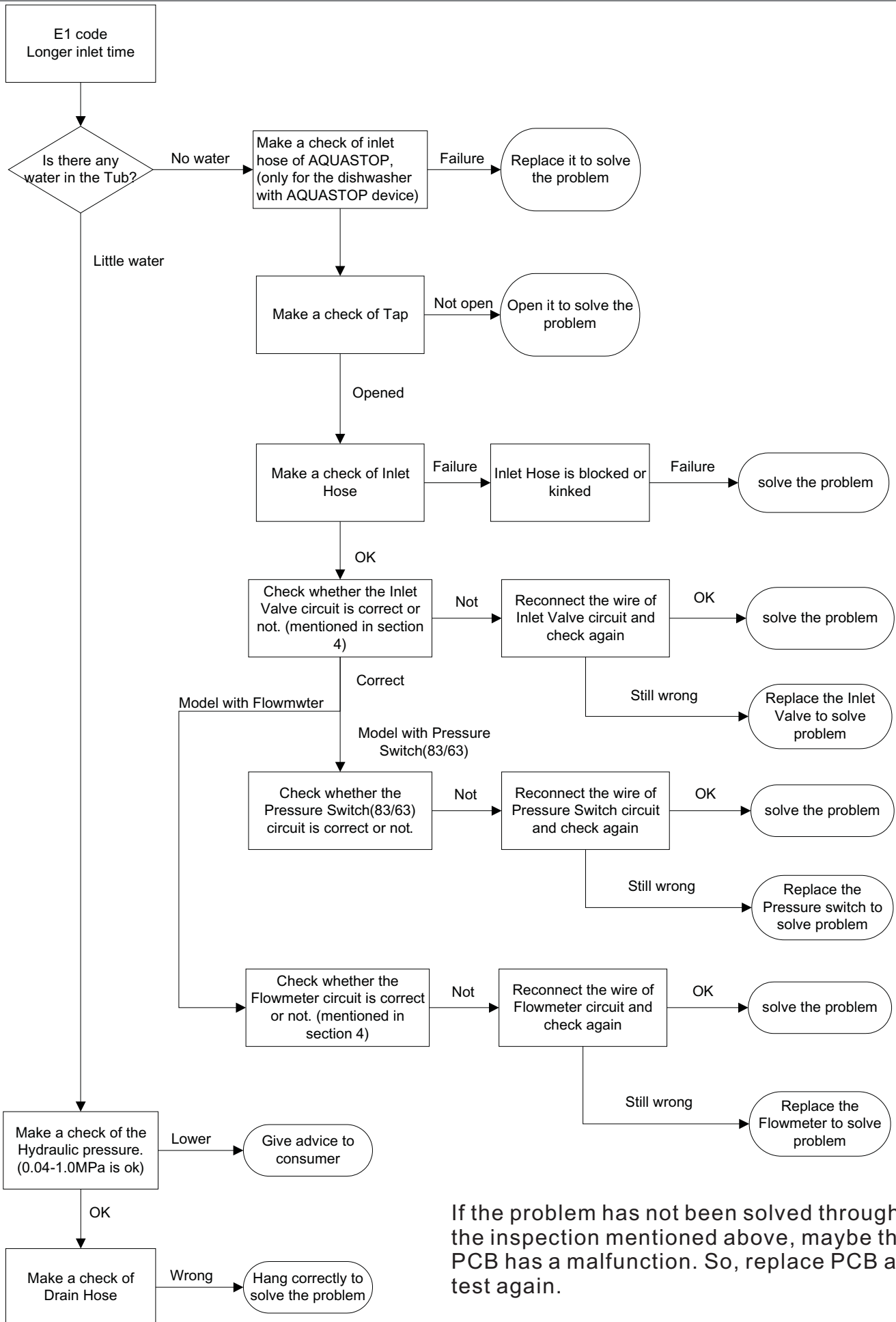

If the problem has not been solved through all the inspection mentioned above, maybe the PCB has a malfunction. So, replace PCB and test again.

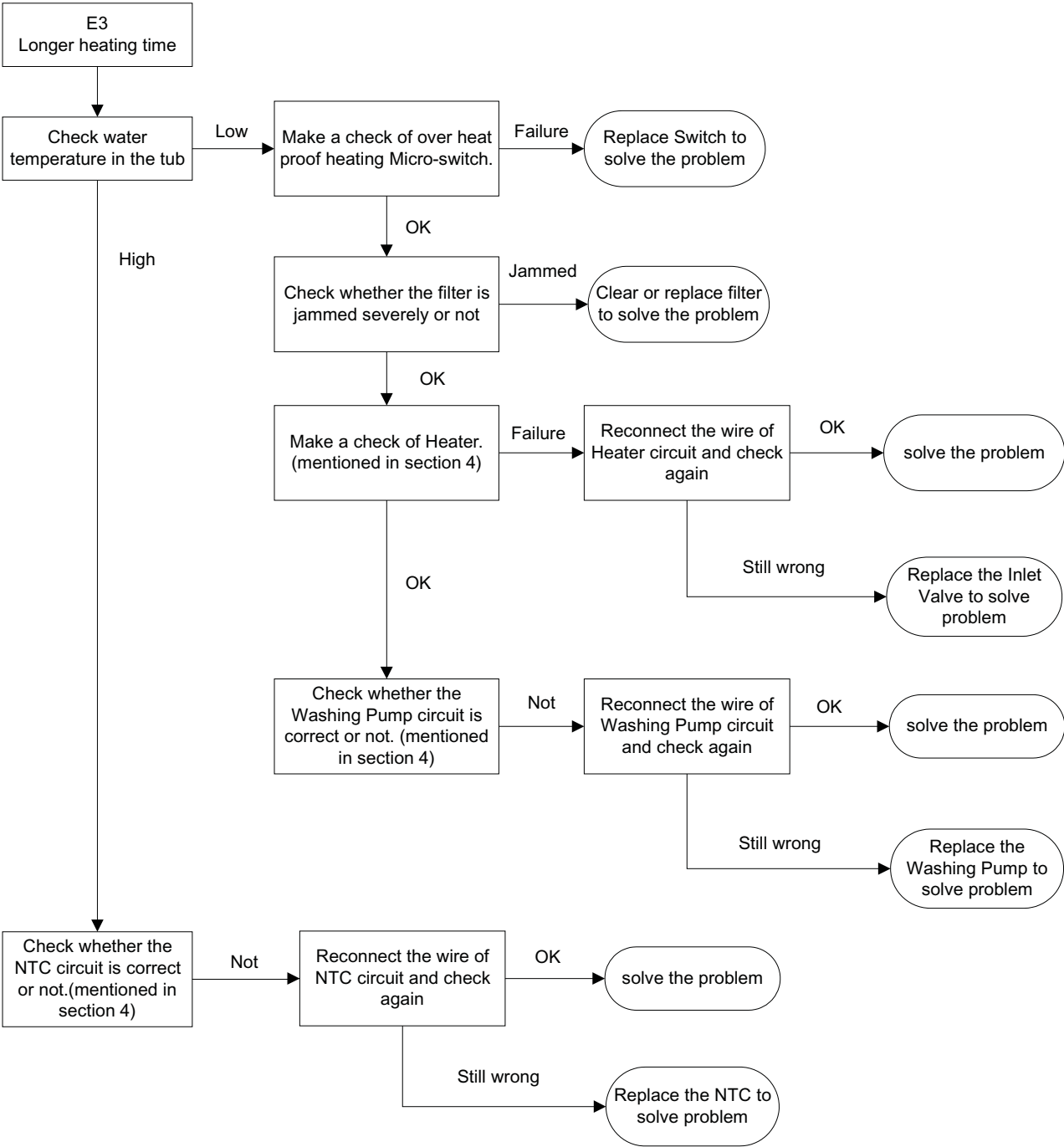

E4 tree -> Inspection

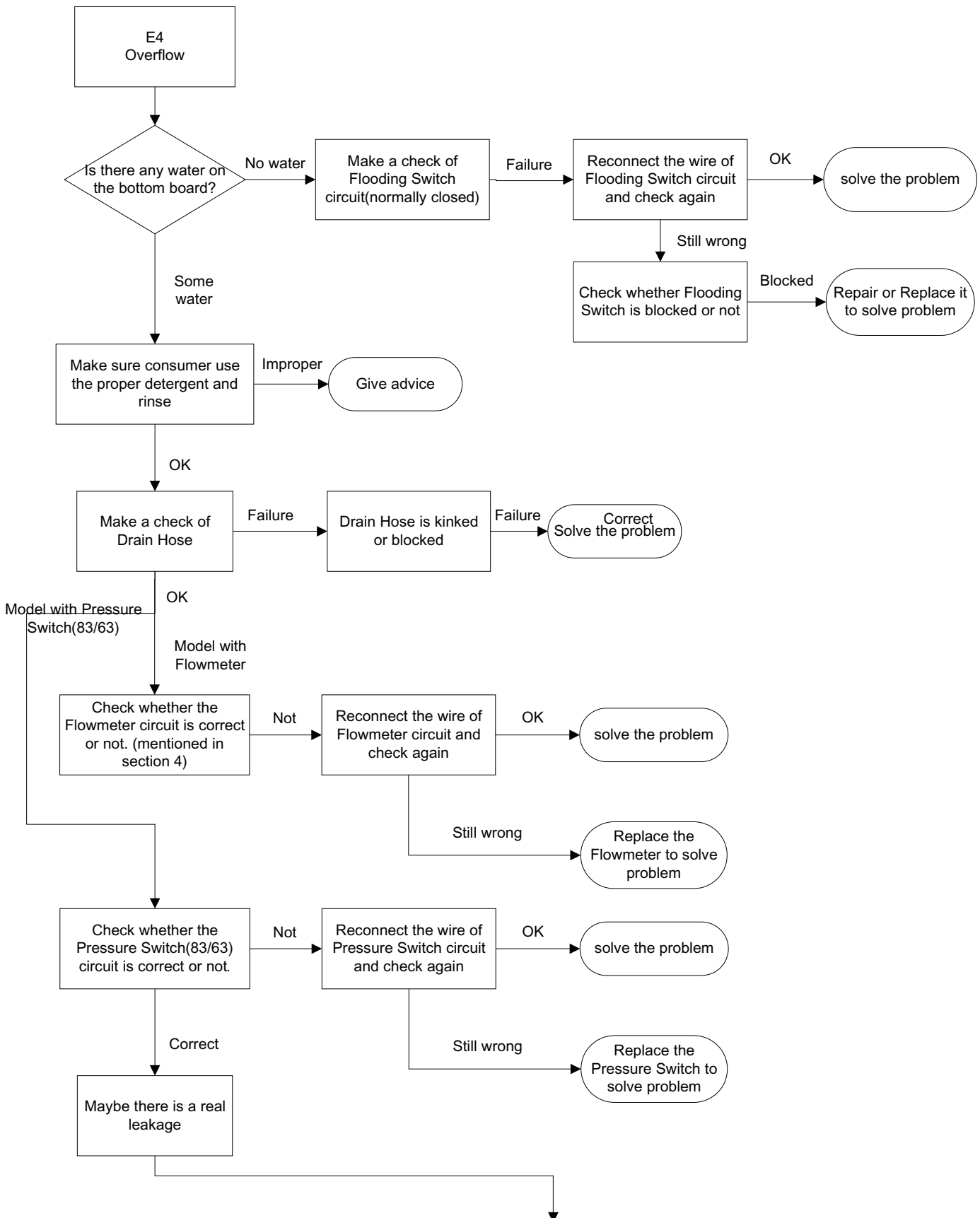

Do as follows

Remove two side panels

Remove the water from the bottom board and make sure there is no water at the bottom board.

Restart the dishwasher with a strong or standard wash program as a leakage could easily repeat at a higher temperature and after a long period of running time.

Observe the bottom tray every twenty minutes.

If any water appears, you will found out which areas, such as motor, drain pump, sump, softener, and hoses between them, and also clips at the end of each hose, besides the weld seam at the bottom of the tub.

If hours passed, but no water comes out, you should stop the dishwasher with sufficient water in the inner tub, and observe it again after leaving it alone for one to two hours.

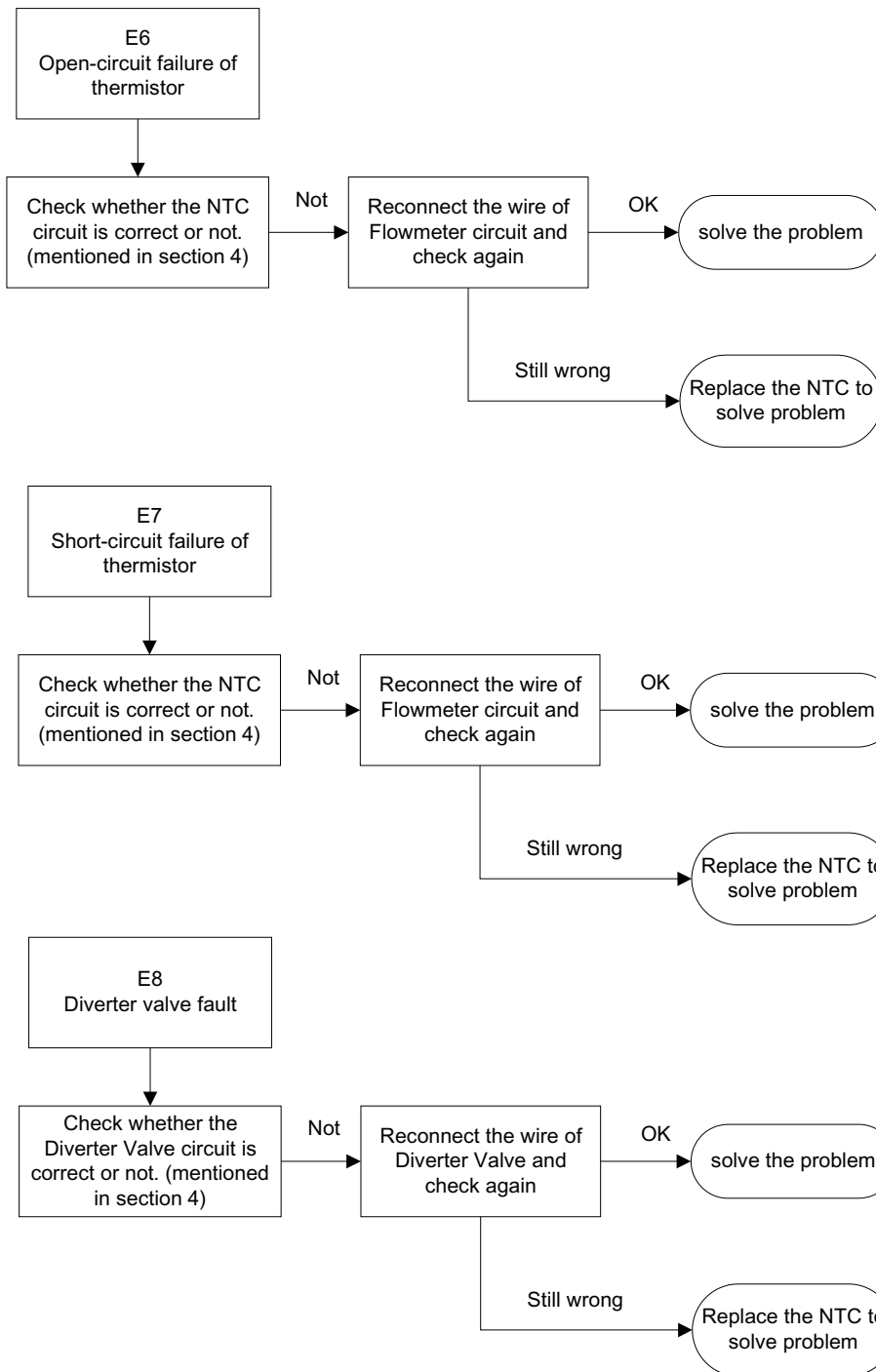

If the problem has not been solved through all the inspection mentioned above, maybe the PCB has a malfunction. So, replace PCB and test again.

Caution:

Because the real situation is unpredictable, inspection trees mentioned in this manual are for reference only.

symptom	possible reason	analysis	operation	remedy
E1 longer inlet time	check the AQUA STOP hose	defective AQUA STOP hose might cut off the water inlet route	for mechanical AQUA STOP hose, check whether the mechanical device is lock or not	replace the hose
	check the water supply	the tap isn't open	for electronic AQUA STOP hose, check whether the valve circuit is ok or not	reconnect or replace the hose
	check the inlet	lower hydraulic pressure	check whether the tap open or not	give advice
	check the inlet valve	inlet hose is blocked or kinked	make sure the hydraulic pressure in the range from 0.04 to 1.0 Mpa	give advice
	check the flowmeter	loosing connection or defective inlet valve might cause the E1 alarm	unblock or unkink	unblock or unkink
	check the pressure switch (83/63)	for models with flowmeter, defective flowmeter might cause the E1 alarm	check the circuit of inlet valve	reconnect or replace the valve
	check the drain	for models controlling water filling by pressure switch, defective pressure switch might cause the E1 alarm	check the circuit of flowmeter	reconnect or replace flowmeter
	check the pressure switch (140/120)	wrong installation of drain hose might cause water siphon out	check the circuit of pressure switch	reconnect or replace the pressure switch
	check the PCB	defective PCB might cause the E1 alarm	make sure it is intalled properly.(refer to instruction manual)	reinstall drain hose
			listen the sound to check whether the drain pump is run or not	replace the pressure switch (140/120)
			defective PCB might cause the E1 alarm	reconnect or replace PCB
				e

e

					clean the filter and give advice
				Advice: Even though a dishwasher is constantly being pounded with water and soap, it needs an occasional cleaning. Food particles, hard water deposits, mildew, mold and bacteria can build up along the surfaces and in the crevices of a dishwasher. Cleaning a dishwasher regularly will keep it functioning properly, keep your family healthy and safe, and keep your dishes coming out sparkling and safe. Make sure the hydraulic pressure in the range from 0.04 to 1.0 Mpa.	give advice
E3 heating fault	severely jammed filter might cause E3 alarm, so give advice to end customer on clean regularly the interior of dishwasher.	check the filter			
	low hydraulic pressure might cause the less filling water	check the hydraulic pressure			
	wrong installation of drain hose might cause water siphon out	check the drain hose			reinstall drain hose
	washing pump doesn't running might cause E3 alarm	check washing pump			replace the washing pump
	malfunction of heater or NTC might cause E3 alarm	check heater and NTC			replace the capacitor
	abnormal anti-drying pressure switch might cause E3 alarm	check anti-drying pressure switch			
	defective PCB also might cause E3 alarm, but its probability is small.	check PCB			replace the defective component
					replace the anti-drying pressure switch
					reconnect or replace PCB
					give advice to end customer advice on use the amount of detergent used during the wash cycle according to instruction manual

	check whether the appliance is level	if appliance is not level, it might cause the E4 alarm	make sure the appliance is level	level appliance
E4 overflow	check the drain pump	defective drain pump might cause the E4 alarm	the first step of all the washing program is drain, which could be used to test whether drain pump work normally or not	replace the drain pump
	check the amount of filling water	too much filling water could make a overflow	for models controlling water filling by pressure switch(83/63), run test program and check whether the amount of filling water is normal or not.	repace the pressure switch(83/63)
	check the float microswitch	sticking float microswitch could cause the E4 alarm	for models controlling water filling by flowmeter, run test program and check whether the amount of filling water is	replace the flowmeter
	find where leakage is	if there is a real leakage, finding where leakage is and solving the problem would be	disassemble the bottom tray and check whether the float microswitch moves freely up and down	repair or replace the float microswitch
			to find and solve problem, do as suggestion mentioned in service manual	repair or replace the defective component
E6 & E7 open-circuit & short-circuit	check the NTC	if the appliance detect the malfunction of NTC thermistor, E6 or E7 would be set off	check the NTC circuit and measure the resistance of NTC thermistor	reconnect or replace the NTC thermistor
	check the PCB	if the NTC thermistor is ok, but the alarm still be set off, the PCB might have defect	change the PCB to see if the appliance is run normally	reconnect or replace PCB
	check the loading	improper loading could block the spray arm, so give advice to end customer on how to load dishes and silverware peoperly.	following the advice on how to load mentioned in instruction manual, which is the necessary condition of getting good washing performance	give advice
	check filter	severely jammed filter might cause E3 alarm, so give advice to end customer on clean regularly the interior of dishwahser.	Advice: Even though a dishwasher is constantly being pounded with water and soap, it needs an occasional cleaning. Food particles, hard water deposits, mildew, mold and bacteria can and do build up along the surfaces and in the crevices of a dishwasher. Cleaning a dishwasher regularly will keep it functioning properly, keep your family healthy and safe, and keep your dishes coming out sparkling	clean the filter and give advice
	check the using program	improper program might cause poor performance		

check the use of detergent and rinse	improper amount of detergent and rinse aid and poor quality detergent and rinse aid might cause poor performance	refer to instruction manual	give advice
check the setting of salt consumption	improper salt consumption might cause the poor performance	Observe whether there are water spots or white film on washed dishes and glass which caused by hard water mineral. If water is too hard, there is a need to adjust salt consumption to adopt to the situation.(refer to instruction)	adjust salt consumption
check dispenser	malfunction of dispenser might cause the poor performance	Run the test program to see whether dispenser open normally.	replace the dispenser
poor washing performance		make sure the appliance is level	level appliance
		wrong installation of drain hose might cause water siphon out, so make sure it is installed properly.(refer to instruction)	reinstall drain hose
		low hydraulic pressure might cause the less filling water, so make sure the hydraulic pressure in the range from 0.04 to	give advice
		for models controlling water filling by flowmeter, defective flowmeter might cause less filling water. When you have eliminated other causes of less water, you could roughly judge the flowmeter is something wrong.	replace flowmeter
check the water level	less water might cause the poor performance	for models controlling water filling by pressure switch(83/63), defective pressure switch might cause less filling water. When you have eliminated other causes of less water, you could roughly judge the flowmeter is something wrong.	replace pressure switch
check heater and NTC	malfunction of heater or NTC might cause E3 alarm	When you have eliminated other causes of less water, you could roughly judge the pressure switch is something wrong. defective PCB also might cause less filling water, but its probability is small. So, the last choose is replace PCB.	replace PCB
check washing pump	washing pump not running	measure temperature of water in tub continuously when test program is running to see whether temperature increasing (aproximate 2 °C/min) is normal and the appliance pause when the water temperature reach 60 degreee or not. listen to the sound of appliance to see whether washing pump run or not	replace the defective component
			replace the washing pump

poor drying performance	check loading	improper loading might cause water remains on the dishes. Make sure tilt the dishes and load the glass bottom-side-up.	following the advice on how to load mentioned in instruction manual, which is the necessary condition of getting good drying performance	give advice
	check the using program	improper program might cause poor performance	refer to instruction manual	give advice
	check rinse aid dispenser	Rinse aid is formulated to ensure that food and chemical residues are not redeposited on your dishes during the final rinse cycle and dishwasher get expected drying performance. Malfunction of dispenser might cause the rinse	make sure the rinse aid container is not empty and rinse aid is normally release in the cycle.	fill rinse aid or replace dispenser
	-	get better drying performance	The air drying process can be speeded up if you open the dishwasher just after it is finished and the dishes are still hot. This will allow the moist air to leave the dishwasher as the dishes cool and dry.	give advice
noise	check whether the noise is normal	some audible sound are normal	-	give advice
	check the loading	dishes are not secure in the rack or something small has dropped	ensure everything is secured in the dishwasher	reload and give advice
	check the washing pump	malfunction of washing pump might make a abnormal noise	check the washing motor whether run normally	replace washing pump
	check the drain pump	blocked or defective drain pump might make a abnormal noise	check the drain motor whether run correctly	replace drain pump

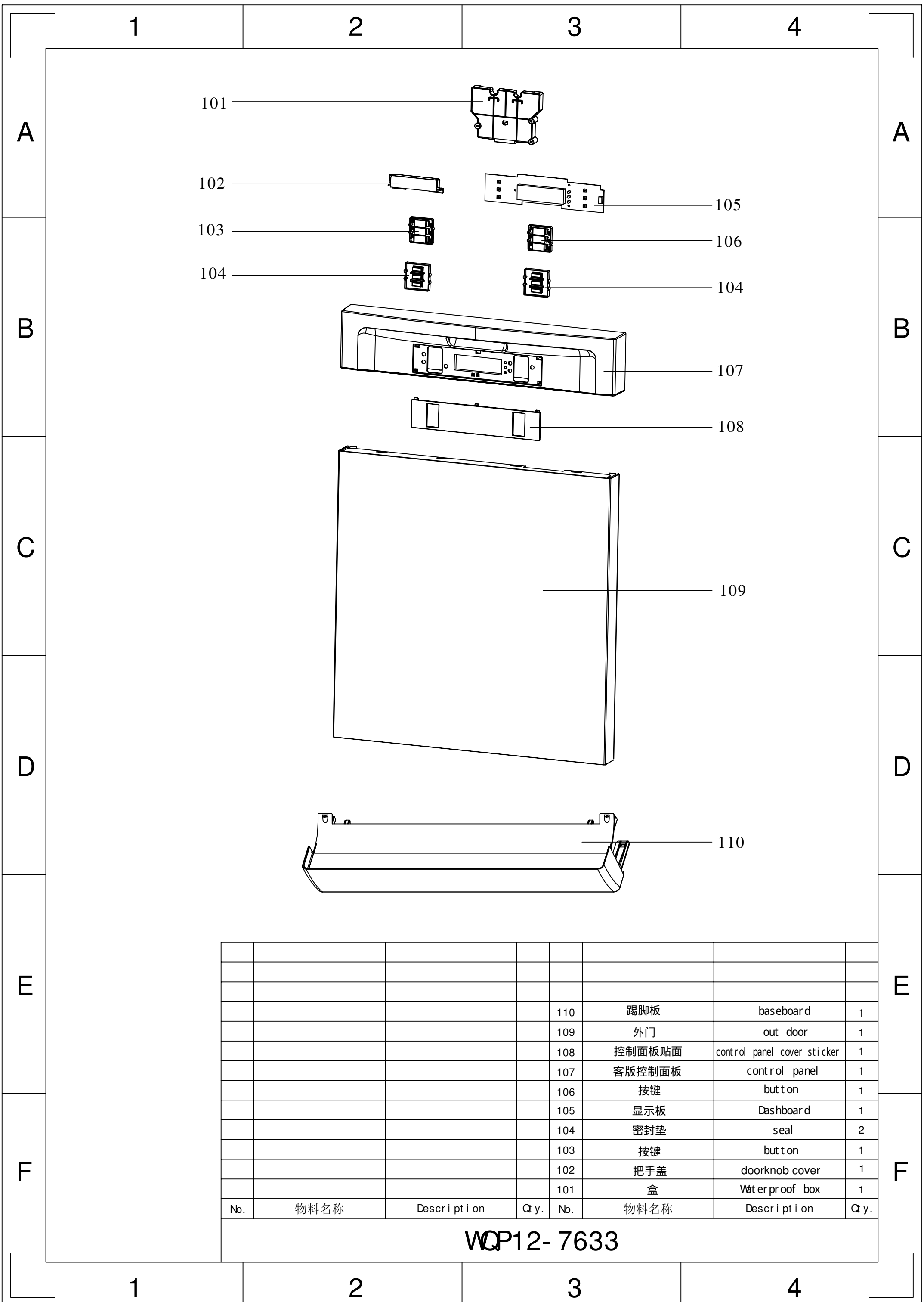

				110	踢脚板	baseboard	1
				109	外门	out door	1
				108	控制面板贴面	control panel cover sticker	1
				107	客版控制面板	control panel	1
				106	按键	button	1
				105	显示板	Dashboard	1
				104	密封垫	seal	2
				103	按键	button	1
				102	把手盖	doorknob cover	1
				101	盒	Waterproof box	1
No.	物料名称	Description	Qty.	No.	物料名称	Description	Qty.

WQP12-7633

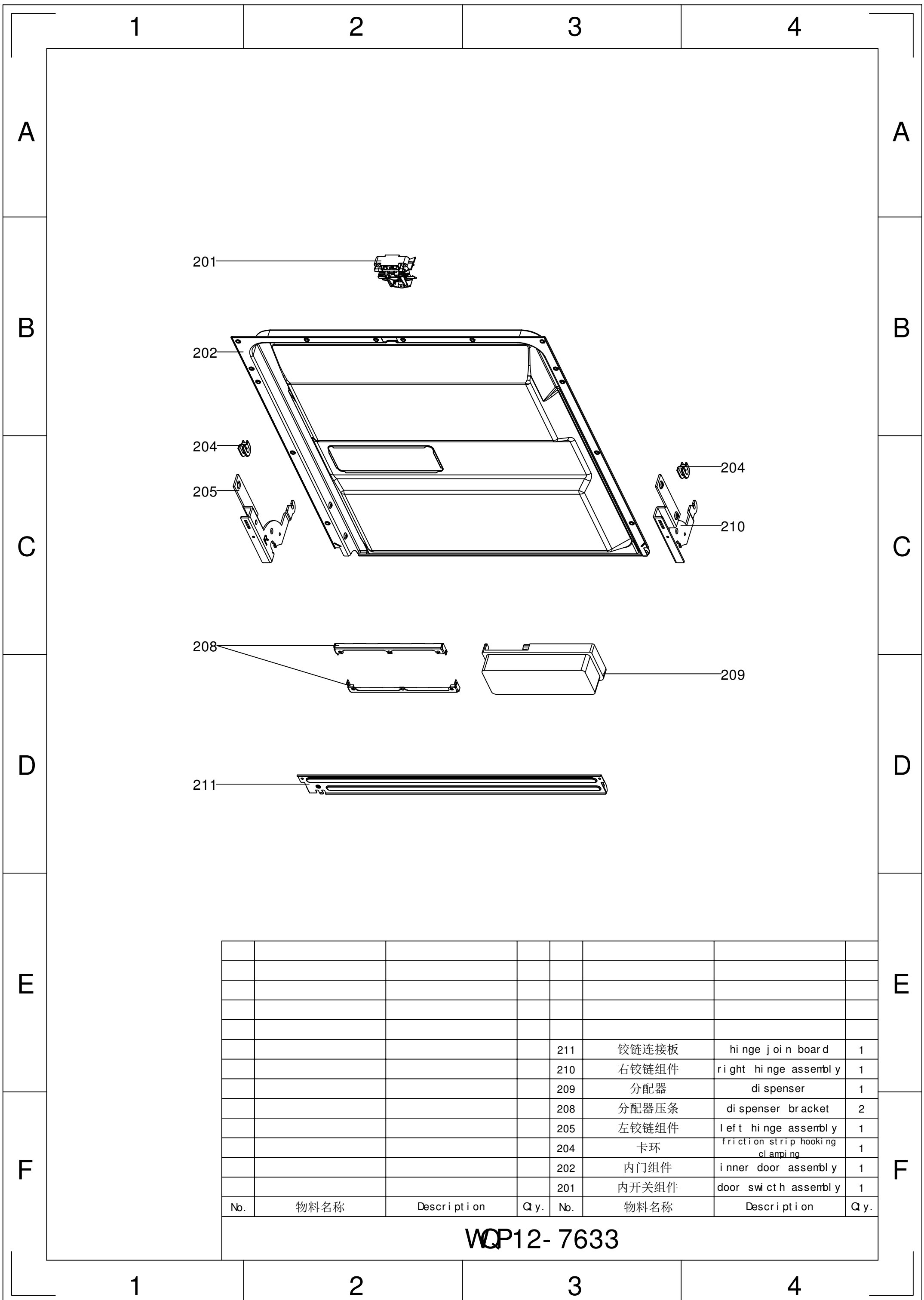

				211	铰链连接板	hi nge j oi n board	1
				210	右铰链组件	ri ght hi nge asse nbl y	1
				209	分配器	di spen ser	1
				208	分配器压条	di spen ser brack et	2
				205	左铰链组件	l eft hi nge asse nbl y	1
				204	卡环	fr i ct i on st r i p h o o k i n g cl a m p i n g	1
				202	内门组件	i n n e r d o o r a s s e n b l y	1
				201	内开关组件	d o o r s w i t c h a s s e n b l y	1
No.	物料名称	Descri pti on	Qty.	No.	物料名称	Descri pti on	Qty.

WQP12-7633

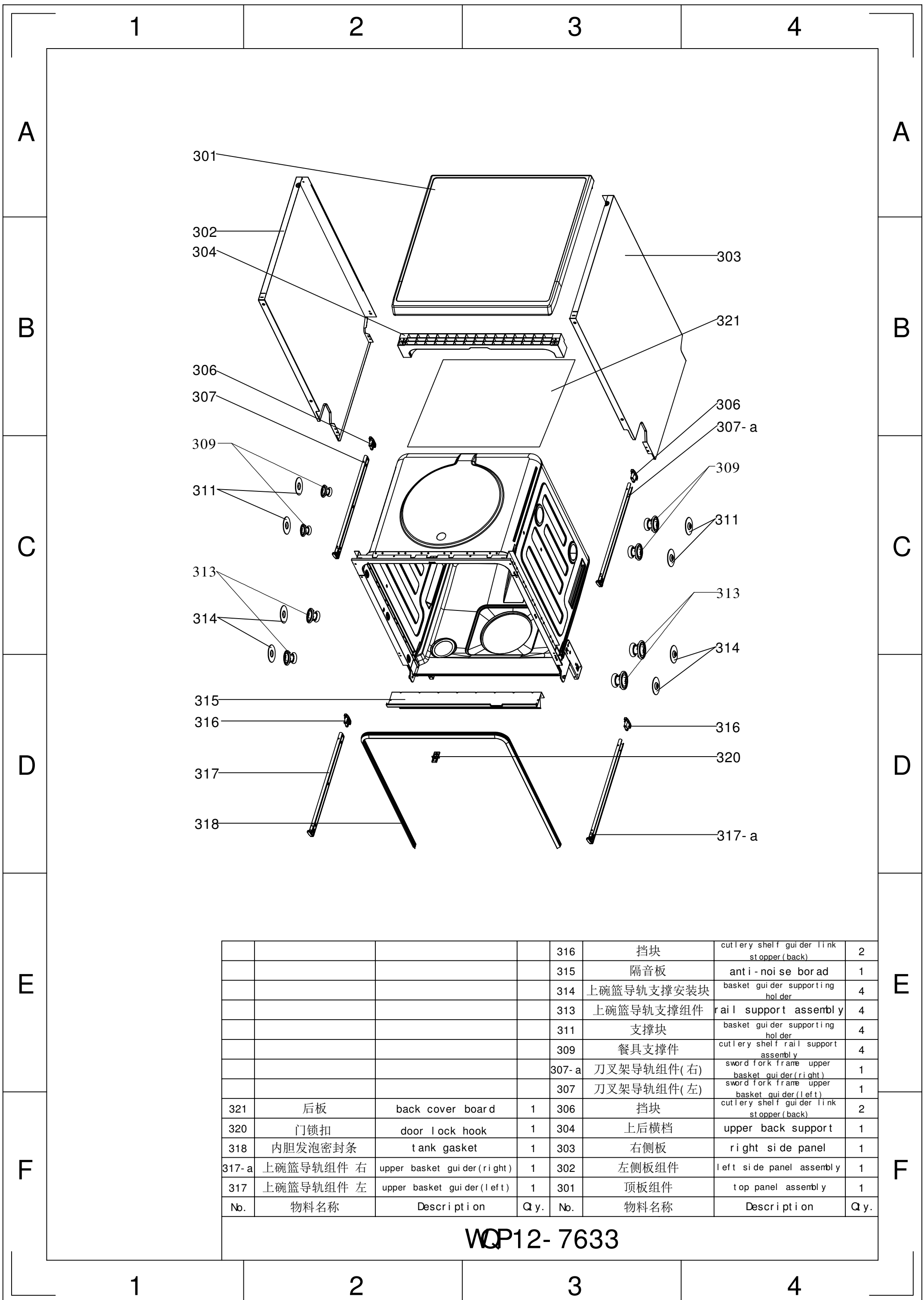

				316	挡块	cutlery shelf guide link stopper (back)	2
				315	隔音板	anti-noise board	1
				314	上碗篮导轨支撑安装块	basket guide supporting holder	4
				313	上碗篮导轨支撑组件	rail support assembly	4
				311	支撑块	basket guide supporting holder	4
				309	餐具支撑件	cutlery shelf rail support assembly	4
				307-a	刀叉架导轨组件(右)	sword fork frame upper basket guide(right)	1
				307	刀叉架导轨组件(左)	sword fork frame upper basket guide(left)	1
321	后板	back cover board	1	306	挡块	cutlery shelf guide link stopper (back)	2
320	门锁扣	door lock hook	1	304	上后横档	upper back support	1
318	内胆发泡密封条	tank gasket	1	303	右侧板	right side panel	1
317-a	上碗篮导轨组件 右	upper basket guide(right)	1	302	左侧板组件	left side panel assembly	1
317	上碗篮导轨组件 左	upper basket guide(left)	1	301	顶板组件	top panel assembly	1
Nb.	物料名称	Description	Qty.	Nb.	物料名称	Description	Qty.

WQP12-7633

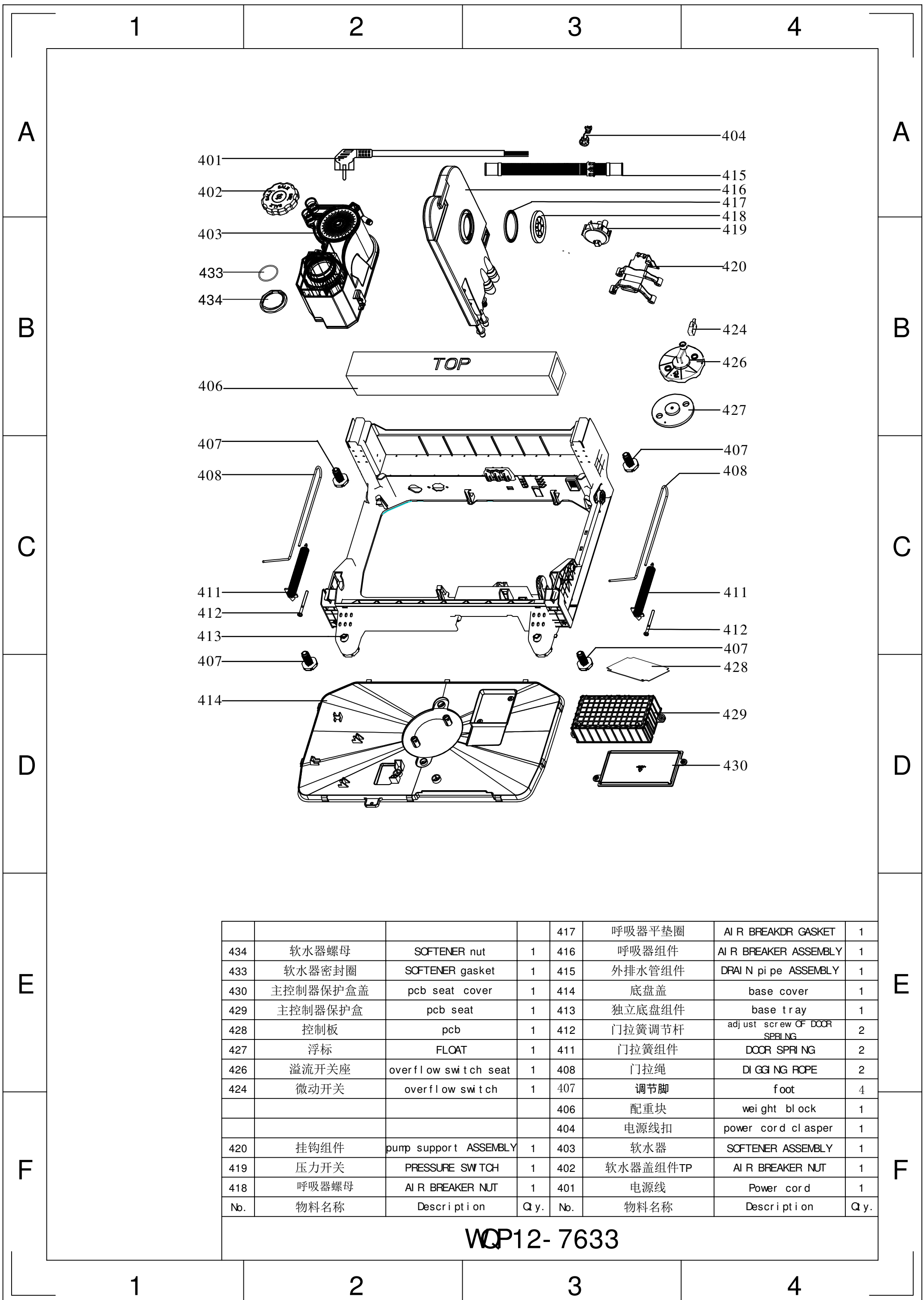

				417	呼吸器平垫圈	AI R BREAKDR GASKET	1
434	软水器螺母	SOFTENER nut	1	416	呼吸器组件	AI R BREAKER ASSEMBLY	1
433	软水器密封圈	SOFTENER gasket	1	415	外排水管组件	DRAI N pi pe ASSEMBLY	1
430	主控制器保护盒盖	pcb seat cover	1	414	底盘盖	base cover	1
429	主控制器保护盒	pcb seat	1	413	独立底盘组件	base tray	1
428	控制板	pcb	1	412	门拉簧调节杆	adjust screw OF DOOR SPRI NG	2
427	浮标	FLOAT	1	411	门拉簧组件	DOOR SPRI NG	2
426	溢流开关座	overflow switch seat	1	408	门拉绳	DI GGI NG ROPE	2
424	微动开关	overflow switch	1	407	调节脚	foot	4
				406	配重块	wei ght bl ock	1
				404	电源线扣	power cord cl asper	1
420	挂钩组件	pump support ASSEMBLY	1	403	软水器	SOFTENER ASSEMBLY	1
419	压力开关	PRESSURE SW TCH	1	402	软水器盖组件TP	AI R BREAKER NUT	1
418	呼吸器螺母	AI R BREAKER NUT	1	401	电源线	Power cord	1
Nb.	物料名称	Descri pt ion	Q t y.	Nb.	物料名称	Descri pt ion	Q t y.

WQP12-7633

1

2

3

4

A

A

B

B

C

C

D

D

E

E

F

F

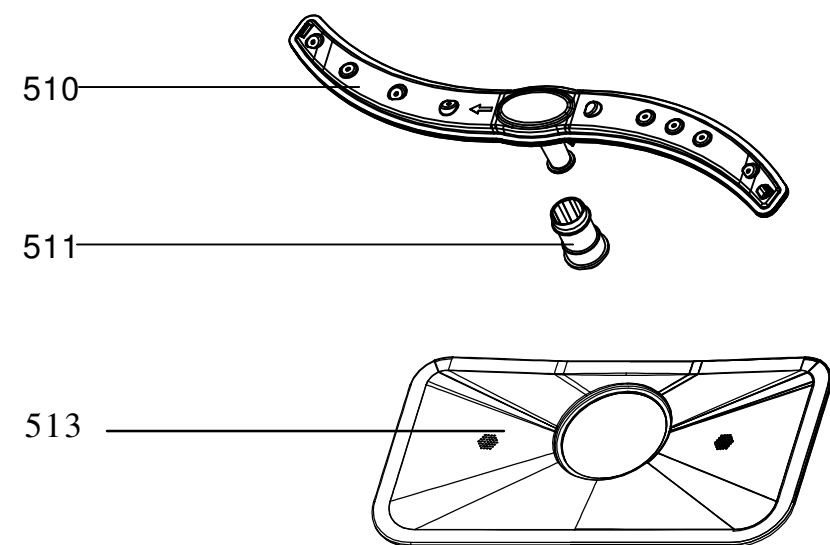
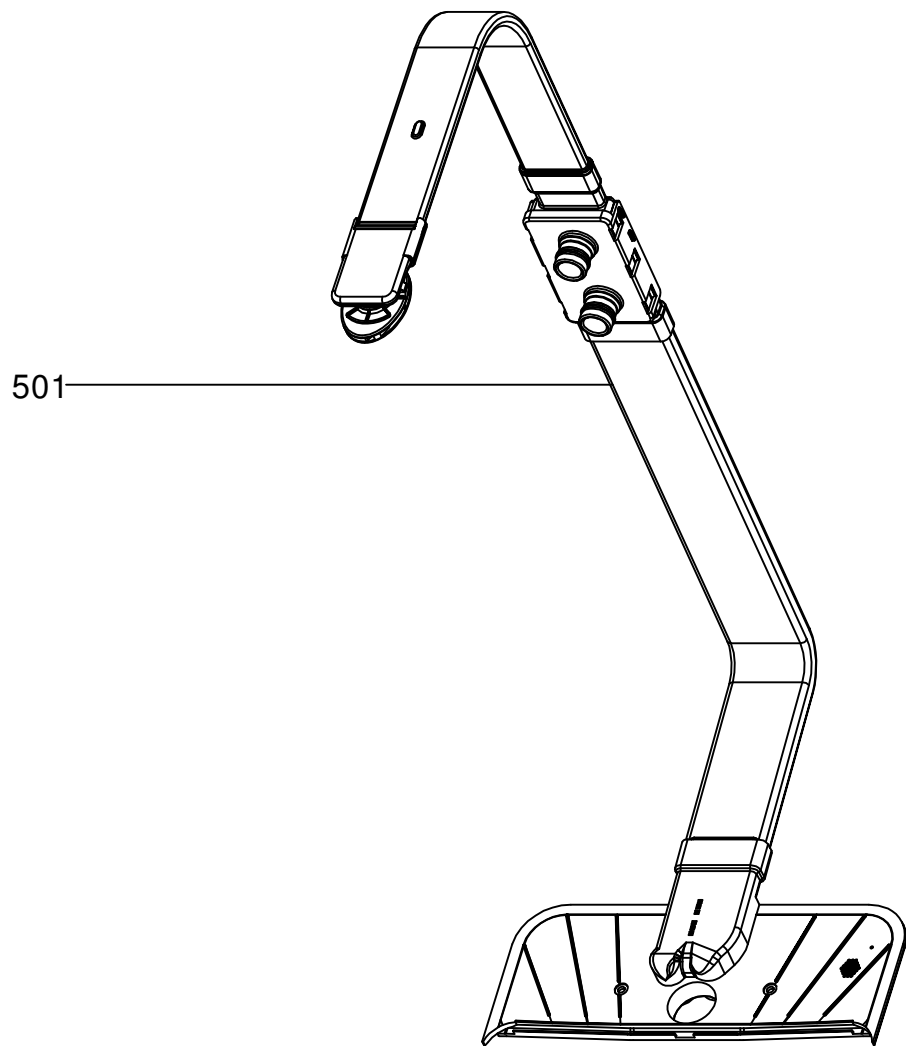

				513	平面过滤器	plane filter	1
				511	下喷臂座	sprayer seat	1
				510	下喷臂	lower sprayer	1
				501	内水管组件	inner pi pe	1
No.	物料名称	Descri pt i on	Qt y.	No.	物料名称	Descri pt i on	Qt y.

WQP12-7633

1

2

3

4

	1	2	3	4										
A								A						
B								B						
C								C						
D								D						
E								E						
F								F						
								1	2	3	4			

				625	单耳无级卡箍	Clamp	2
				624	进水管	inlet pipe	1
				618	加热管组件	heating elements	1
				614	电机电泵总成	induction pump	1
				613	出水管	outlet hose of softener	1
				612	压力开关PVC管	pvc pipe	1
				611	水杯组件	sump assembly	1
				610	永磁同步泵	Permanent magnet synchronous pump	1
				607	洗涤泵进水管	inlet pipe	1
631	线束	wiring harness	1	606	柱面过滤器	cylinder filter	1
630	浊度传感器组件	turbidity transducer	1	605	单耳无级卡箍	396 Clamp	2
629	温度传感器组件	thermostat	1	604	提杯	filter handle	1
628	内排水管	inner drain pipe	1	601	水杯密封圈	sump gasket	1
Nb.	物料名称	Description	Qty.	Nb.	物料名称	Description	Qty.

WQP12-7633

1

2

3

4

A

A

B

B

C

C

D

D

E

E

F

F

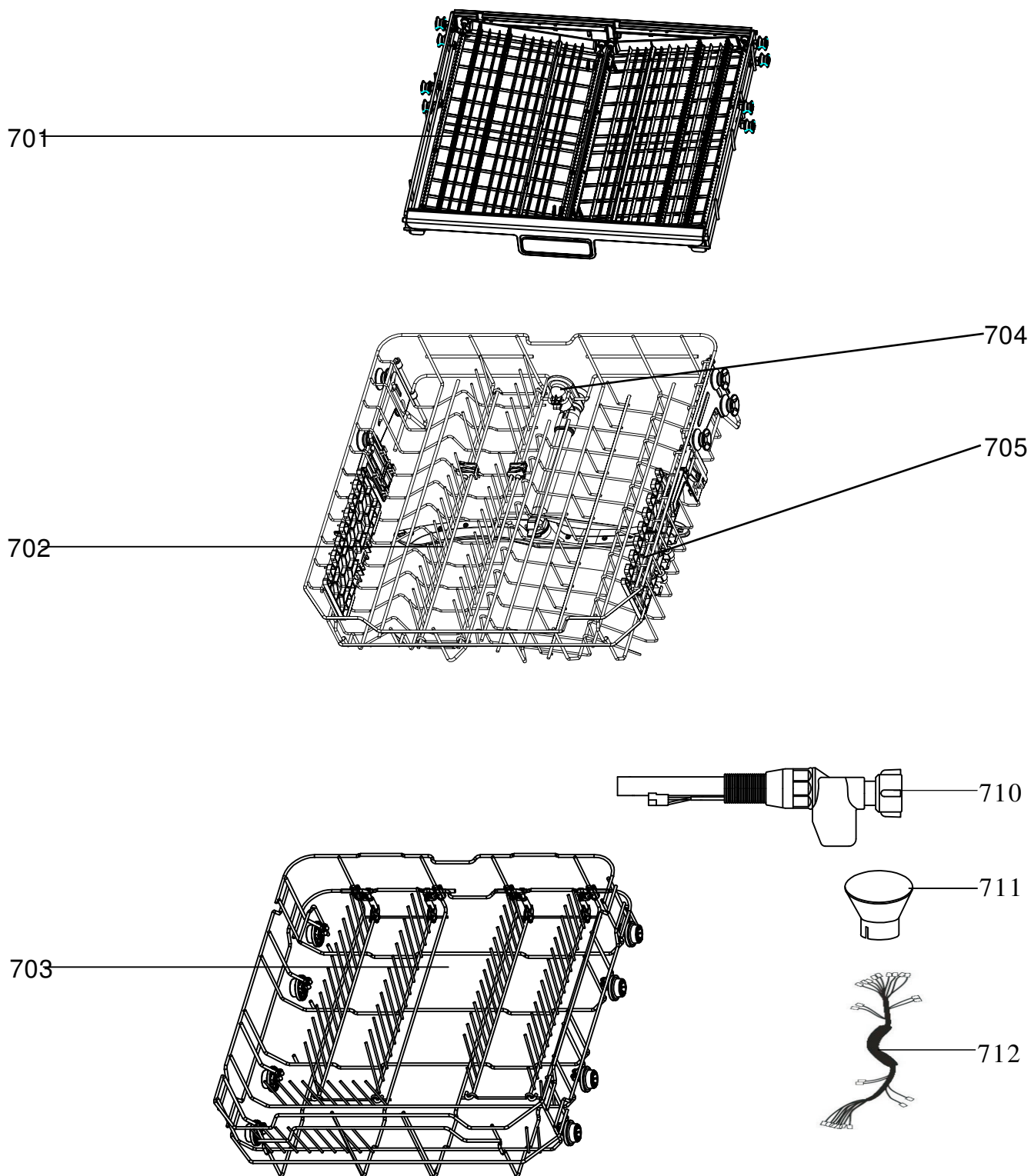

				712	线束	wiring harness	1
				711	盐斗	salt filler	1
				710	进水管组件	inlet hose assembly	1
				705	杯托	cup holder	2
				704	中喷臂组件	MIDDLE SPAYER ASSEMBLY	1
				703	下碗篮组件	lower basket assembly	1
				702	上碗篮组件	Upper basket	1
				701	刀叉托盘组件	cutlery assembly	1
Nb.	物料名称	Description	Qty.	Nb.	物料名称	Description	Qty.

WQP12-7633

1

2

3

4

NO.	Part No.	Description	Qty.
101	12176000016790	Waterproof box	1
102+107	12176000A30145	control panel	1
103	12176000016791	button	1
104	12676000001861	seal	2
105	17176000015273	Dashboard	1
106	12176000016787	button	1
108	12176000A30144	display window cover	1
109	12276000006660	out door	1
110	12176000004079	baseboard	1
201	17476000000052	door switch assembly	1
202	12276000005288	inner door assembly	1
204	12176000003629	friction strip hooking clamping	2
205	12276000001731	left hinge assembly	1
208	12276000001459	dispenser bracket	2
209	17476000001420	dispenser	1
210	12276000001778	right hinge assembly	1
211	12276000001852	hinge join board	1
301	12176000016267	TOPPANEL	1
302	12276000000972	left side panel assembly	1
303	12276000001246	right side panel	1
304	12176000003869	upper back support	1
306	12176000008517	cutlery shelf guider link stopper(back)	2
307	12276000001341	sword fork frame upper basket guider(left)	1
307-a	12276000001344	sword fork frame upper basket guider(right)	1
309	12176000010336	cutlery shelf rail support assembly	4
311	12176000008444	basket guider supporting holder	4
313	12176000010412	rail support assembly	4
314	12176000008573	basket guider supporting holder	4
315	12276000001818	anti-noise borad	1
316	12176000008496	upper basket guider link stopper(back)	2
317	12276000001357	upper basket guider(left)	1
317-a	12276000001360	upper basket guider(right)	1
318	12676000000859	tank gasket	1
320	12176000009491	door lock hook	1
321	12176000010289	back cover board	1
401	17476000005309	powercord	1
402	12176000010640	softener cover	1
403	17476000005645	Softener	1
404	12176000009490	power cord clasper	1
406	12776000000023	Counterweight	1
407	12176000009741	foot	4
408	12976000000392	door rope	2
411	12976000000133	door spring assembly	2
412	12976000001001	adjust screw of door spring	2
413	12176000019564	tray assembly	1
414	12176000015483	base cover	1
415	12676000000138	drain hose assembly	1
416	17476000005724	Airbreather	1
417	12676000000713	air breaker seal	1

418	12176000013663	air breaker nut	1
419	17476000001222	pressure switch	1
420	12276000008925	motor holder assembly	1
424	17476000001137	overflow switch	1
426	12176000003125	overflow switch seat	1
427	12876000000050	sleeve cover	1
428	17176000015271	main pcb	1
429	12176000016897	PCB Box cover	1
430	12176000016896	PCB Box	1
433	12676000001801	softener seal	1
434	12176000009513	softener nut	1
501	12176000009472	inner pipe	1
510	12176000009161	lower sprayer	1
511	12176000008645	sprayer seat	1
513	12176000003689	plane filter	1
601	12676000001461	sump seal	1
604	12176000009640	filter handle	1
605	12976000000327	396 clamp	2
606	12176000003676	cylinder filter	1
607	12676000000146	washing pump outlet pipe	1
610	11001011000449	Permanent magnet synchronous pump	1
611	12176000016230	Sumpassembly	1
612	12676000000651	pvc pipe	1
613	12676000001521	softener outlet pipe	1
614	17476000001561	induction pump assembly	1
618	17476000001408	heating elements	1
624	12676000000100	washing pump inlet pipe	1
625	12976000000308	clamp	2
628	12676000000947	inner drain pipe	1
629	17176000012008	thermostat	1
630	17176000000306	turbidity transducer	1
631	17476000000382	wiring harness	1
701	12176000002815	cutlery assembly	1
702	12976000001474	Upper basket	1
703	12976000001463	lower basket assembly	1
704	12176000009173	MIDDLE SPAYER ASSEMBLY	1
705	12176000013316	cup rack	2
710	17476000001307	inlet hose assembly	1
711	12176000010312	salt filler	1
712	17476000005576	Wireharness	1