

5. REPAIR PARTS LIST

5-1-2. CABINET (R) SECTION

ns : not supplied

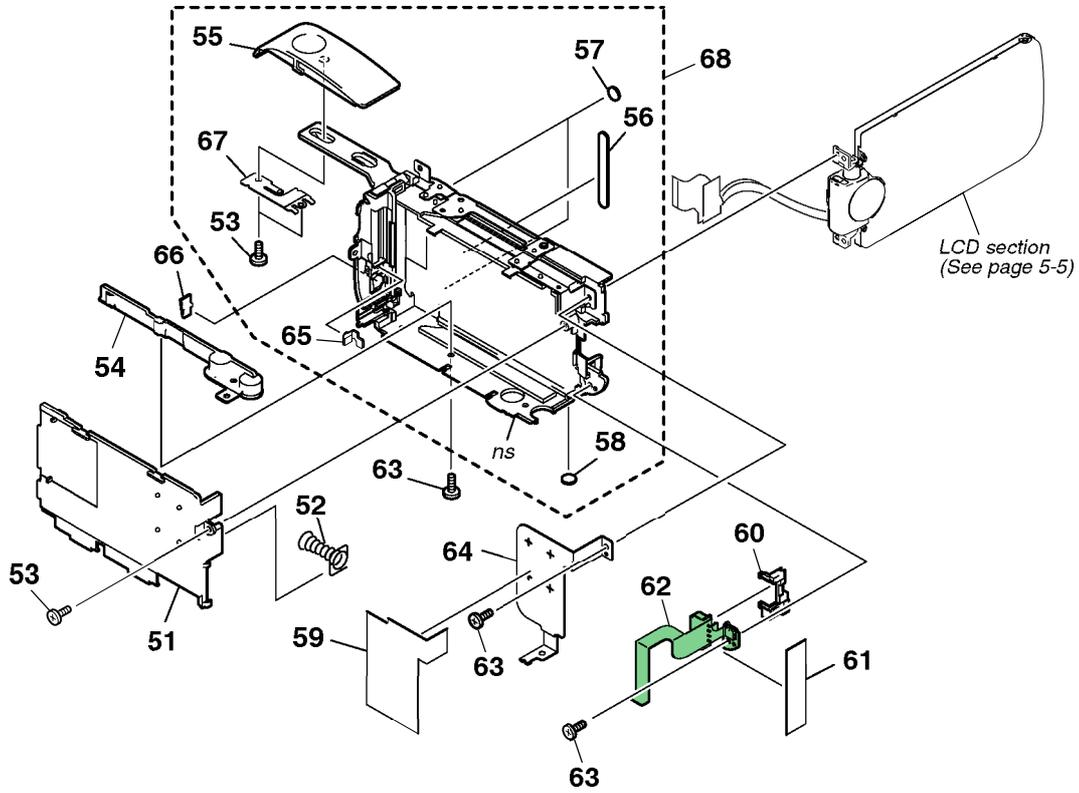

Ref. No.	Part No.	Description
51	2-549-143-01	HOLDER, BATTERY
52	2-583-964-01	SPRING, EJECT
53	3-078-890-01	SCREW, TAPPING
54	2-549-142-01	TRIPOD
55	2-549-067-01	LID, BATTERY
56	2-549-078-01	CUSHION (L), PANEL
57	2-549-074-01	CUSHION (R), PANEL
58	2-549-075-01	FOOT, RUBBER
59	2-549-152-01	SHEET (BT), RADIATION
60	2-549-123-01	HOLDER, BATTERY TERMINAL

Ref. No.	Part No.	Description
61	3-052-196-01	LENS FLEXIBLE SHEET
62	A-1084-128-A	FP-063 FLEXIBLE BOARD, COMPLETE
63	3-989-735-31	SCREW (M1.7), LOCK ACE, P2
64	2-549-144-01	PLATE (R), GROUND
65	2-549-071-01	TALLY, MS
66	2-583-686-01	LID, CPC
67	2-549-076-01	RETAINER, BT LID
68	X-2025-583-1	CABINET (R) ASSY (DARK SILVER)
68	X-2025-584-1	CABINET (R) ASSY (SILVER)

5. REPAIR PARTS LIST

5-1-3. LCD SECTION

ns : not supplied

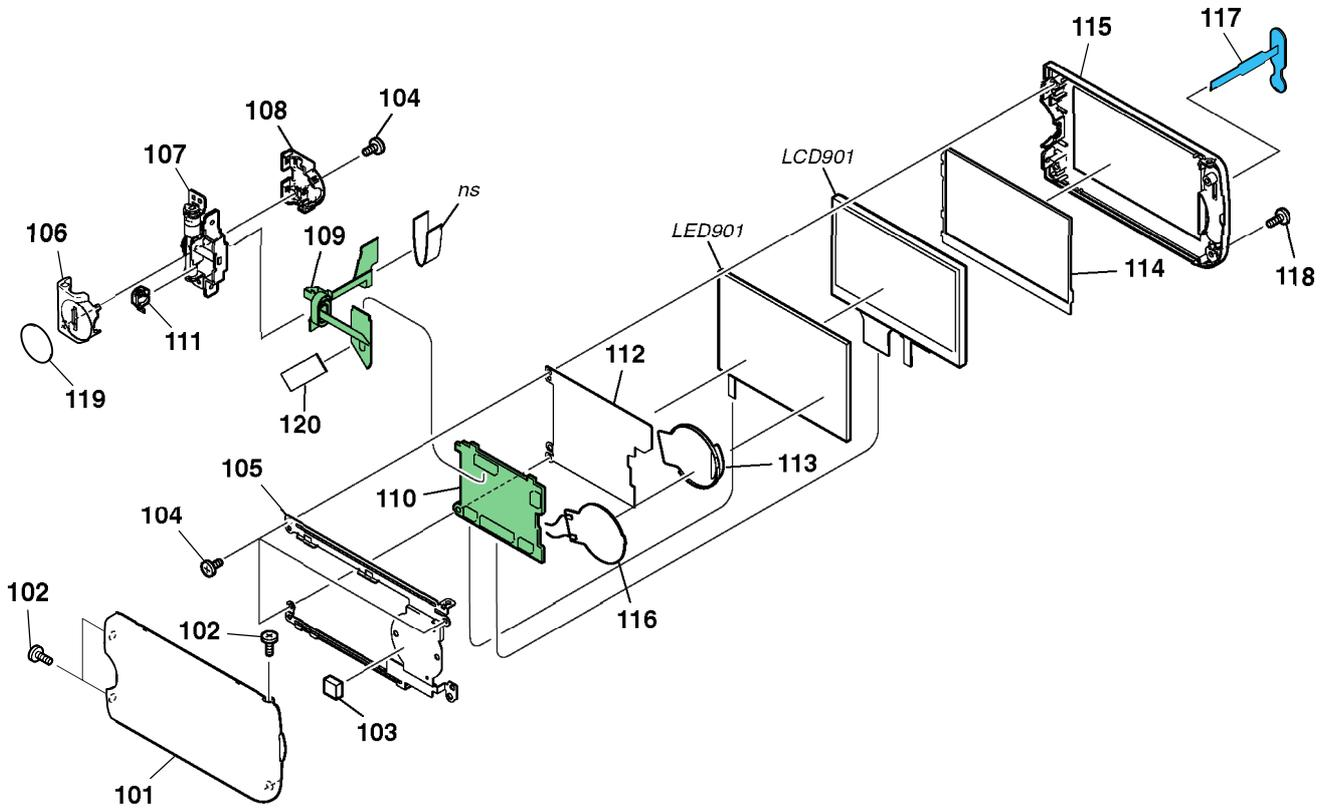

Ref. No.	Part No.	Description
101	2-549-104-01	CABINET (C), P (DARK SILVER)(HC90)
101	2-549-104-11	CABINET (C), P (DARK SILVER)(HC90E)
101	2-549-104-21	CABINET (C), P (SILVER)(HC90)
101	2-549-104-31	CABINET (C), P (SILVER)(HC90E)
102	3-989-735-31	SCREW (M1.7), LOCK ACE, P2
103	2-582-777-01	CUSHION, SPEAKER
104	3-989-735-01	SCREW (M1.7), LOCK ACE, P2
105	2-549-117-01	FRAME, P
106	2-549-115-01	COVER (C), HINGE (DARK SILVER)
106	2-549-115-11	COVER (C), HINGE (SILVER)
107	X-2025-585-1	HINGE ASSY
108	2-549-116-01	COVER (M), HINGE (DARK SILVER)
108	2-549-116-11	COVER (M), HINGE (SILVER)
109	A-1084-130-A	FP-066 FLEXIBLE BOARD, COMPLETE
110	A-1084-127-A	PD-240 BOARD, COMPLETE

Ref. No.	Part No.	Description
111	2-583-650-01	GUARD (Z), FLEXIBLE
112	2-549-126-01	SHEET, SP BASE ADHESIVE
113	2-549-120-01	BASE, SPEAKER
114	2-549-119-01	CUSHION, PANEL
115	2-549-105-01	CABINET (M), P (DARK SILVER)(J)
115	2-549-105-11	CABINET (M), P (DARK SILVER)(EXCEPT J)
115	2-549-105-21	CABINET (M), P (SILVER)(J)
115	2-549-105-31	CABINET (M), P (SILVER)(EXCEPT J)
116	1-825-997-11	BUZZER, PIEZOELECTRIC
117	1-479-063-21	SWITCH BLOCK, CONTROL (SB9000)
118	3-083-261-01	SCREW, TAPPING
119	2-583-651-01	PLATE, HINGE ORNAMENTAL
120	3-941-343-01	TAPE (A)
LCD901	A-1083-763-A	TP BLOCK ASSY 27STGU
LED901	1-478-929-11	BLOCK, LIGHT GUIDE PLATE (2.7)

5. REPAIR PARTS LIST

5-1-4. CABINET (UPPER) SECTION

ns : not supplied

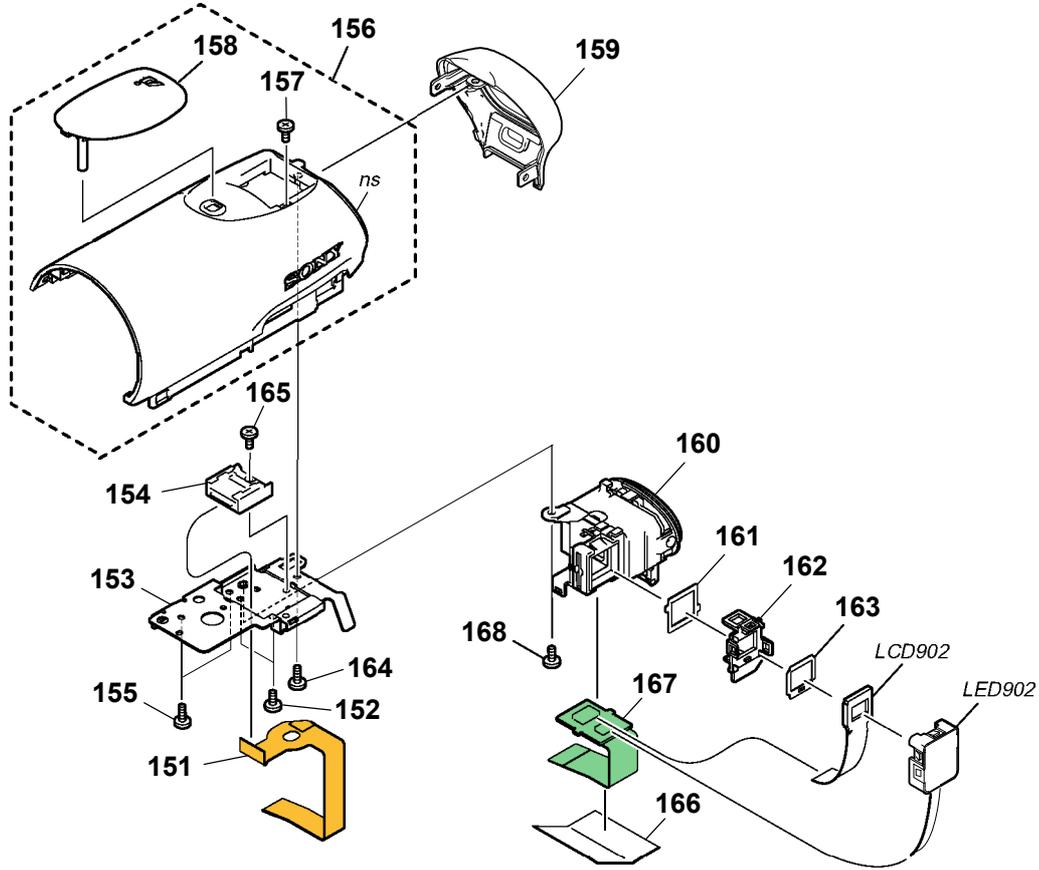

Ref. No.	Part No.	Description
151	1-864-959-11	FP-067 FLEXIBLE BOARD
152	3-989-735-01	SCREW (M1.7), LOCK ACE, P2
153	2-549-163-01	FRAME, SHOE
154	1-818-890-11	CONNECTOR, EXTERNAL (HOT SHOE)
155	3-078-890-01	SCREW, TAPPING
156	X-2025-587-1	CABINET (UPPER) ASSY (DARK SILVER)(J)
156	X-2025-588-2	CABINET (UPPER) ASSY (DARK SILVER) (EXCEPT J)
156	X-2025-589-1	CABINET (UPPER) ASSY (SILVER)(J)
157	3-078-893-21	O PLATE +P2 MAIN EG GRIP M1.7
156	X-2025-590-1	CABINET (UPPER) ASSY (SILVER)(EXCEPT J)
158	2-549-161-01	COVER, SHOE (DARK SILVER)
158	2-549-161-11	COVER, SHOE (SILVER)
159	2-549-162-01	EYE CUP

Ref. No.	Part No.	Description
160	X-2025-591-1	LENS ASSY, VF
161	2-560-810-01	CUSHION (2), LCD
162	2-549-194-01	COVER, LCD
163	2-560-809-01	CUSHION (1), LCD
164	3-080-204-11	SCREW, TAPPING, P2
165	3-080-198-01	SCREW (M1.7), LOCK ACE, P2
166	2-581-675-01	SHEET (VF), RADIATION
167	A-1084-124-A	CK-145 BOARD, COMPLETE (CN8301 and FP-059 FLEXIBLE board are included in this COMPLETE board.)
168	3-078-893-11	O PLATE +P2 MAIN EG GRIP M1.7
LCD902	8-753-226-72	LCX059BKE-1
LED902	1-478-911-11	BLOCK, LIGHT GUIDE PLATE (0.3)

5. REPAIR PARTS LIST

5-1-5. LENS BLOCK SECTION

ns : not supplied

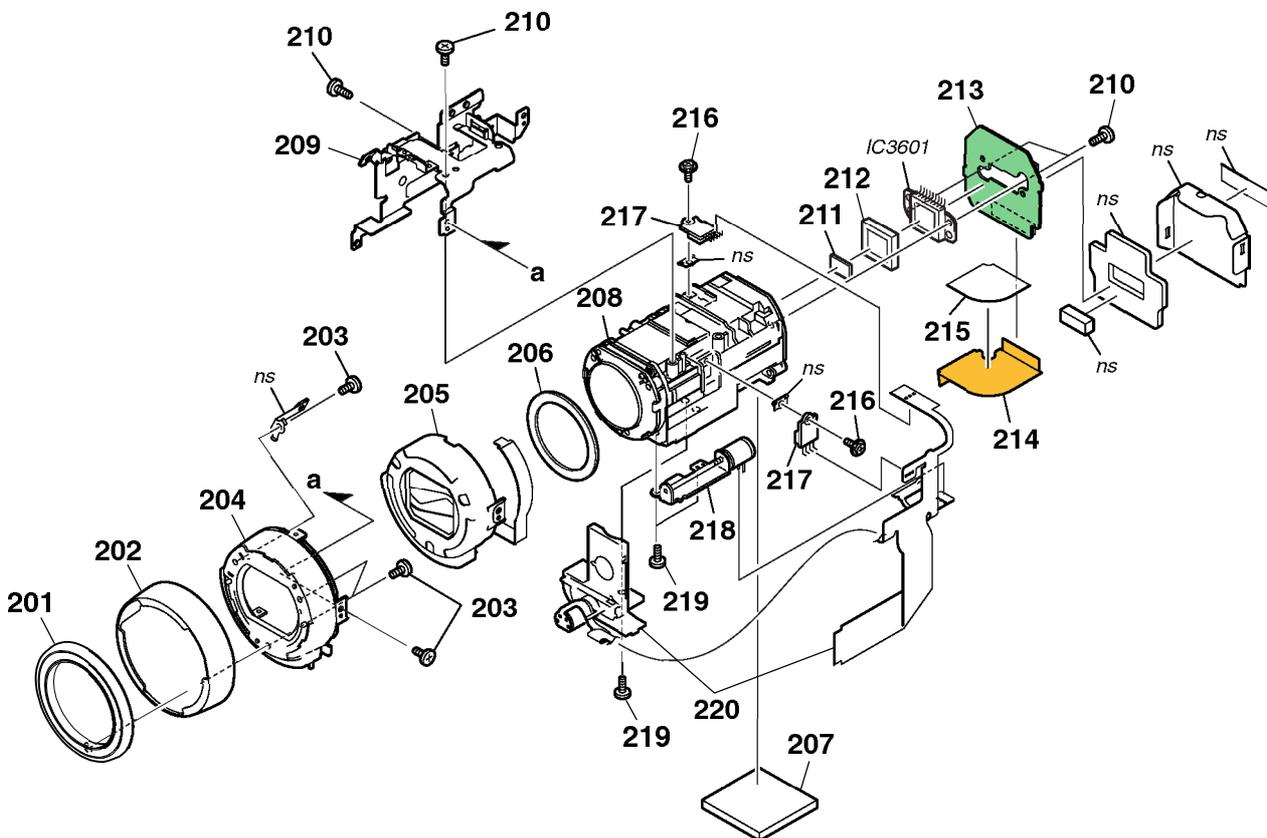

Ref. No.	Part No.	Description
201	2-560-680-01	SCREW, FILTER
202	2-560-681-01	CABINET, ORNAMENT
203	3-080-198-21	SCREW (M1.7), LOCK ACE, P2
204	2-560-678-01	CABINET, BARRIER
205	1-787-278-11	MOTOR UNIT (LENS BARRIER)
206	2-560-692-01	CUSHION (1), LENS MUFFLE
207	2-560-693-01	CUSHION (2), LENS MUFFLE
208	8-848-792-01	DEVICE, LENS LSV-942A
209	2-560-682-01	FRAME, LENS
210	3-078-890-01	SCREW, TAPPING
211	1-758-992-11	OPTICAL FILTER BLOCK
212	3-085-457-01	RUBBER (870), SEAL

Ref. No.	Part No.	Description
213	A-1087-185-A	CD-540 BOARD, COMPLETE (HC90E)
213	A-1084-121-A	CD-540 BOARD, COMPLETE (HC90) (IC3601 is not included in this COMPLETE board.)
214	1-864-954-11	FP-058 FLEXIBLE BOARD
215	2-560-694-01	SHEET (CD), RADIATION
216	3-078-297-01	TAPPING (M1.4)
217	1-477-458-11	SENSOR, GMR (M)
218	1-787-204-11	STEPPING MOTOR, OPTICAL Z940
219	3-713-791-35	SCREW (M1.7X5), TAPPING, P2
220	1-788-144-11	IRIS (IR940)
IC3601	A-1089-147-A	CCD BLOCK ASSY (CCD IMAGER) (IC3601 is not included in this COMPLETE of CD-540 board.)

Be sure to read "Precautions upon replacing CCD imager" on page 4-3 when changing the CCD imager.

CCDイメージャの交換時はサービスマニュアル4-4ページの“CCDイメージャ交換時の注意”を必ずお読みください。

5. REPAIR PARTS LIST

5-1-6. CABINET (L) SECTION-1

ns : not supplied

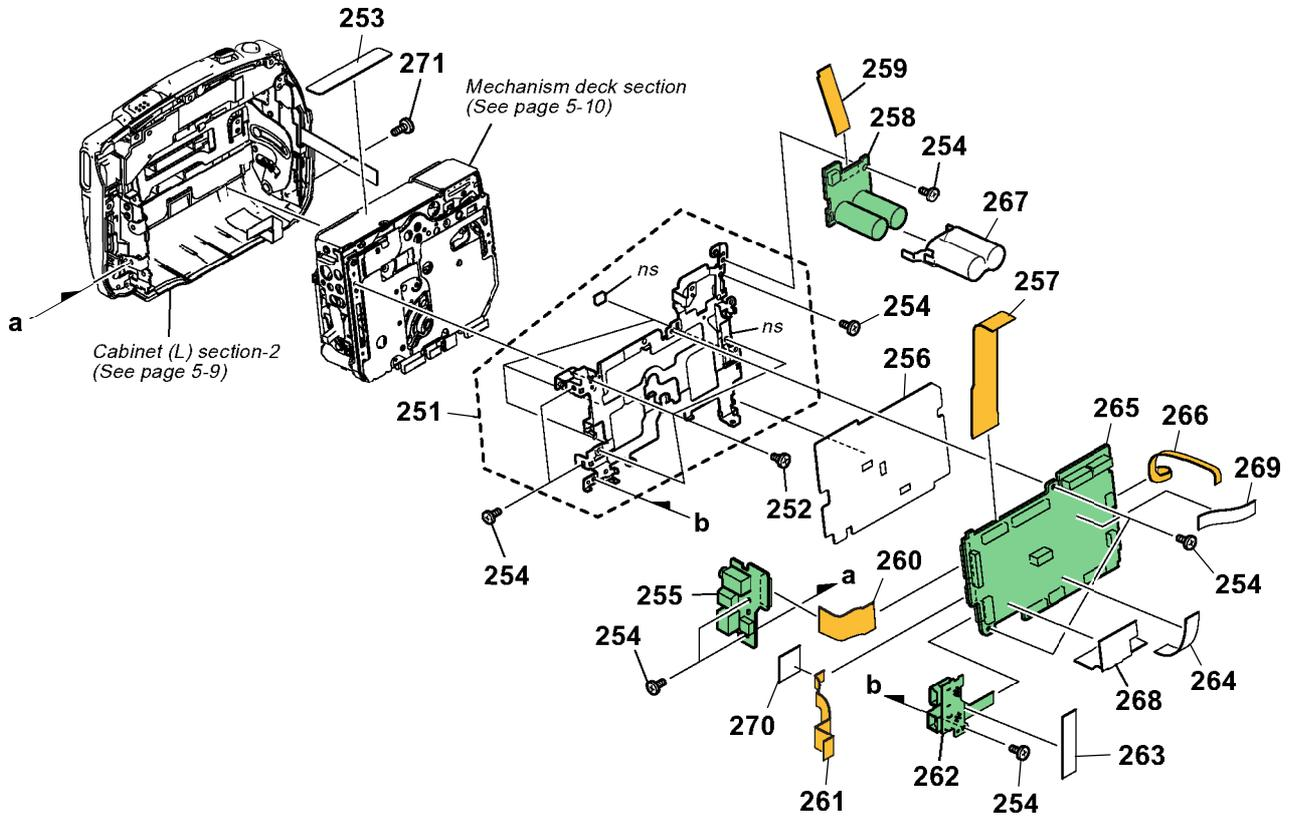

Ref. No.	Part No.	Description
251	X-2048-417-1	FRAME ASSY, MD
252	3-062-214-01	SCREW (M1.4X1.5)
253	2-582-961-01	LABEL (N), LS
254	3-989-735-01	SCREW (M1.7), LOCK ACE, P2
255	A-1084-125-A	JK-280 BOARD, COMPLETE

256	2-560-741-01	SHEET, MD INSULATION
257	1-864-953-11	FP-057 FLEXIBLE BOARD
258	A-1084-126-A	ST-114 BOARD, COMPLETE
259	1-864-962-11	FP-070 FLEXIBLE BOARD
260	1-864-951-11	FP-055 FLEXIBLE BOARD

Ref. No.	Part No.	Description
261	1-864-952-11	FP-056 FLEXIBLE BOARD
262	A-1084-131-A	FP-068 FLEXIBLE BOARD, COMPLETE
263	3-052-196-01	LENS FLEXIBLE SHEET
264	2-582-781-01	SHEET, MD FLEXIBLE PROTECTION
265	A-1089-239-A	VC-380 BOARD, COMPLETE (SERVICE)

266	1-864-961-11	FP-069 FLEXIBLE BOARD
267	2-560-743-01	HOLDER, CAPACITOR
268	2-560-742-01	SHEET, DD SHIELD
269	3-941-343-01	TAPE (A)
270	3-076-631-01	HIMERON T0.25
271	3-989-735-31	SCREW (M1.7), LOCK ACE, P2

5. REPAIR PARTS LIST

5-1-7. CABINET (L) SECTION-2

ns : not supplied

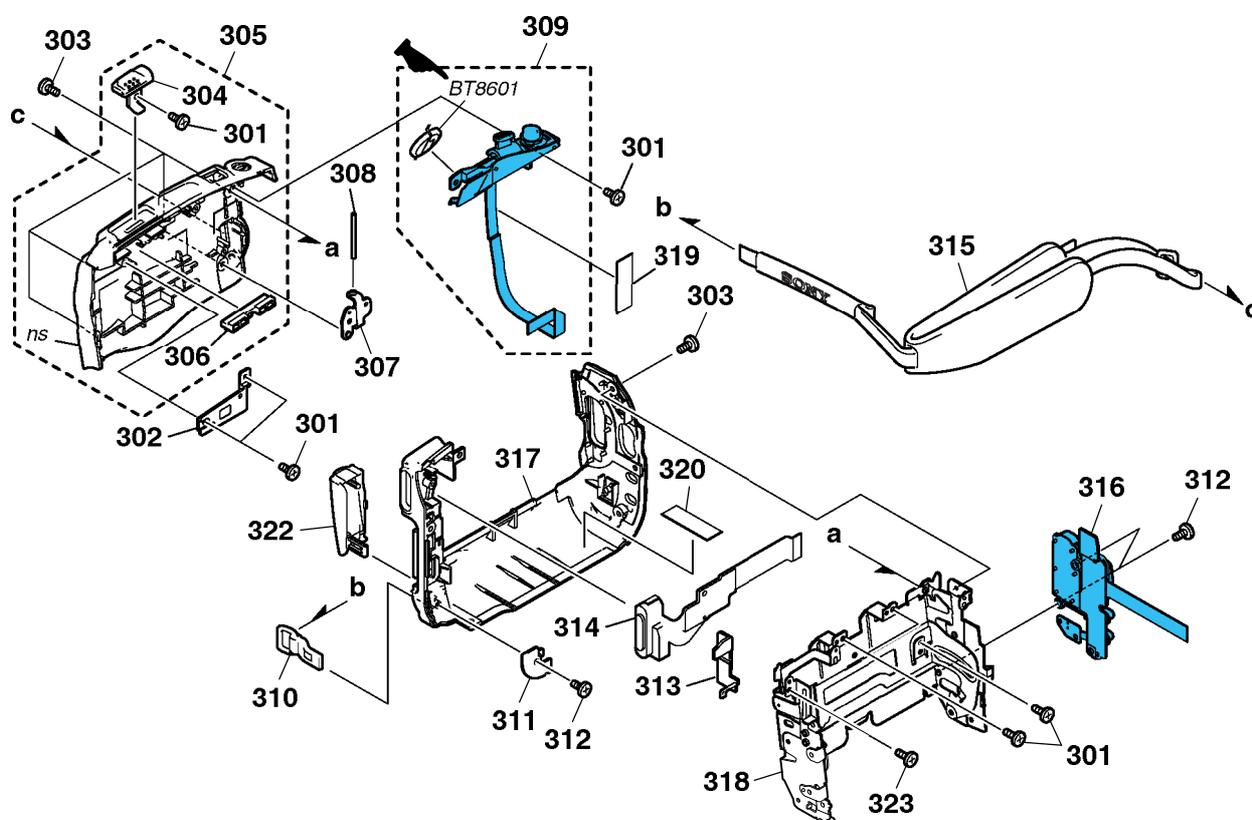

BT8601 (Lithium battery) Control switch block (ZM11600) on the mount position

Ref. No.	Part No.	Description	Ref. No.	Part No.	Description
301	3-080-204-11	SCREW, TAPPING, P2	313	2-580-419-01	HOLDER, ST
302	2-580-418-01	BLIND, EJECT	△ 314	1-479-056-11	FLASH UNIT (CX11600)
303	3-989-735-01	SCREW (M1.7), LOCK ACE, P2	315	2-583-631-01	BELT, GRIP
304	2-549-032-01	KNOB, EJECT	316	1-479-057-11	SWITCH BLOCK, CONTROL (SS11600)
305	X-2025-569-1	CABINET (G) ASSY (J)	317	X-2025-571-1	CABINET (L) ASSY (J)
305	X-2025-570-1	CABINET (G) ASSY (EXCEPT J)	317	X-2025-572-1	CABINET (L) ASSY (EXCEPT J)
306	2-549-034-01	RETAINER, EJECT KNOB	318	X-2025-573-1	FRAME ASSY, CS
307	2-583-605-01	SHEET METAL (REAR), GRIP BELT	319	2-580-434-01	SHEET FLEXI 1
308	2-583-621-01	SHAFT (REAR), GRIP BELT	320	2-583-822-01	SHEET, FLEX 2
309	1-479-055-11	SWITCH BLOCK, CONTROL (ZM11600)	322	2-580-516-01	COVER (L), JACK
310	2-583-616-01	BELT (FRONT), GRIP	323	3-078-890-01	SCREW, TAPPING
311	2-583-603-01	SHEET METAL (FRONT), GRIP BELT	△ BT8601	1-756-128-11	BATTERY, LITHIUM (SECONDARY)
312	3-078-893-21	O PLATE +P2 MAIN EG GRIP M1.7			

CAUTION :

Danger of explosion if battery is incorrectly replaced.
Replace only with the same or equivalent type.

注意

電池の交換は、正しく行わないと破裂する可能性があります。電池を交換する場合には必ず同じ型名の電池又は同等品と交換してください。

The components identified by mark △ or dotted line with mark △ are critical for safety.
Replace only with part number specified.

Les composants identifiés par une marque △ sont critiques pour la sécurité.
Ne les remplacer que par une pièce portant le numéro spécifié.

△印の部品、または△印付の点線で囲まれた部品は、安全性を維持するために、重要な部品です。従って交換時は、必ず指定の部品を使用してください。

5. REPAIR PARTS LIST

5-1-8. OVERALL MECHANISM DECK SECTION

ns : not supplied

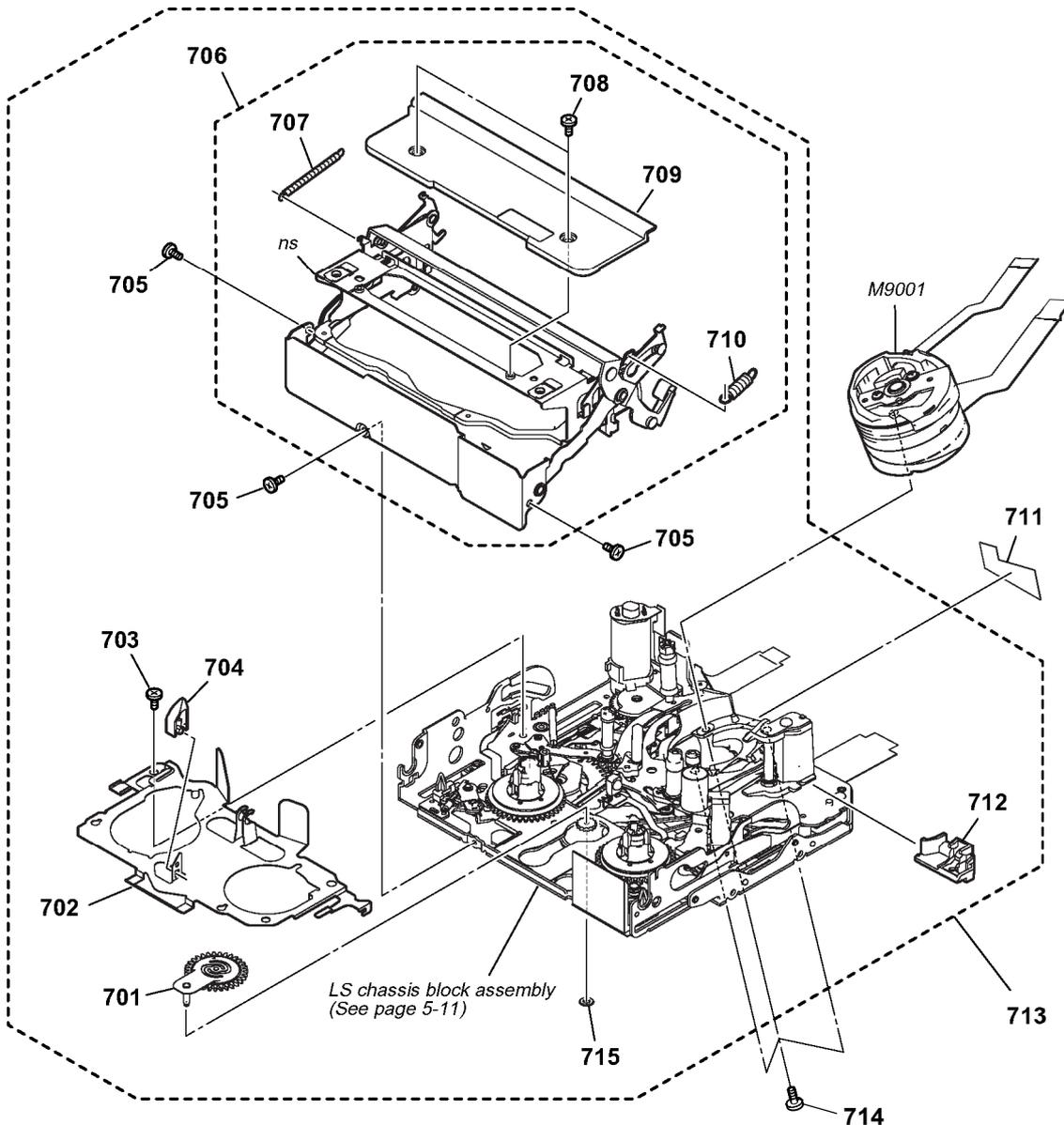

Ref. No.	Part No.	Description
701	X-2024-478-1	PENDULUM ASSY
702	2-342-917-01	LED BASE
703	7-627-850-77	SCREW PRECISION +P M1.4X1.8 TYPE3
704	3-079-366-11	RELEASE, REEL LOCK
705	3-703-816-08	SCREW (M1.4X1.4), SPECIAL HEAD
706	X-2024-450-1	COMPARTMENT ASSY, CASSETTE
707	2-342-926-01	SPRING (ARM S), TENSION COIL
708	2-546-417-01	SCREW (M1.4)

Ref. No.	Part No.	Description
709	2-342-933-01	PLATE, TOP
710	2-342-927-01	SPRING (ARM T), TENSION COIL
711	2-541-585-01	SHEET, FLEXIBLE ADHESIVE
712	2-342-918-01	TG6 CATCHER
713	A-1080-997-A	MD(N100)SUB ASSY_A
714	3-703-816-13	SCREW (M1.4X2.0), SPECIAL HEAD
715	3-315-414-31	WASHER
M9001	A-1087-172-A	DRUM (DEH-33A-R) (SERVICE)

5. REPAIR PARTS LIST

5-1-9. LS/MECHANICAL CHASSIS BLOCK ASSEMBLY-1

ns : not supplied

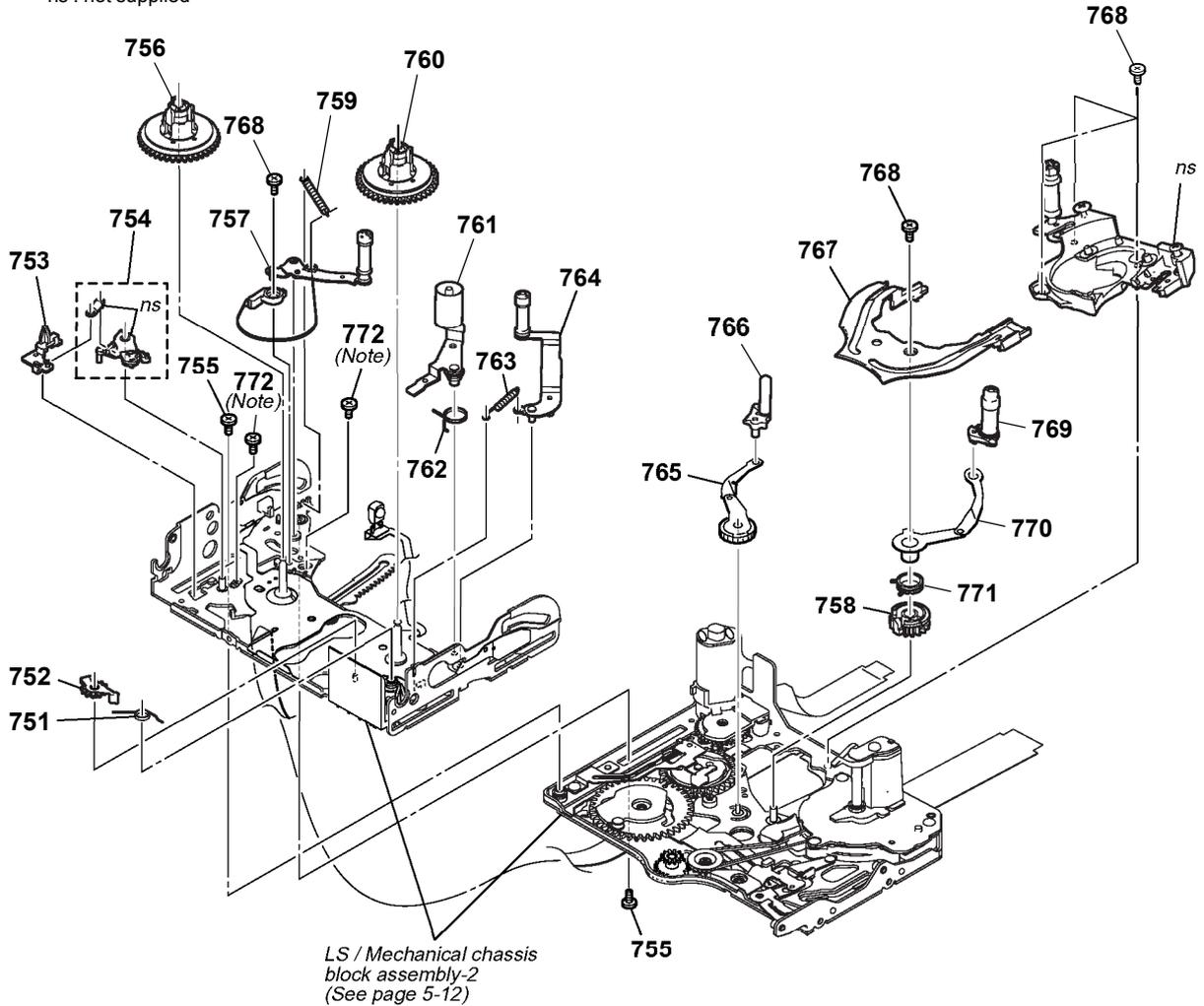

Note: These two screws are the fixing screws of the LS cam plate.
 These two fixing screws are used for adjusting the LS cam plate position.
 (refer to 4-2. LS cam adjustment of DV mechanical adjustment manual IX)

Ref. No.	Part No.	Description
751	2-342-759-01	SPRING, RVS BRAKE
752	A-1083-005-A	BLOCKASSY, RVS BRAKE
753	2-342-731-01	POSITIONING, S
754	A-1083-006-A	BLOCKASSY, S BRAKE
755	3-075-097-11	SCREW (M1.4X1.4), SPECIAL HEAD
756	X-2024-473-1	TABLE ASSY,S REEL
757	A-1083-007-A	BLOCKASSY, TENSION REGULATOR
758	2-342-705-01	GEAR (T), GL
759	2-342-902-01	SPRING, TENSION REGULATOR
760	X-2024-474-1	TABLE ASSY,T REEL
761	X-2024-476-1	ARM ASSY,PINCH

Ref. No.	Part No.	Description
762	2-342-906-01	SPRING (PINCH RETURN), TORSION
763	2-342-626-01	SPRING (RETURN TG6), EXTENSION
764	A-1083-002-A	BLOCK ASSY,TG6
765	X-2024-468-1	ARM ASSY(S), GL
766	X-2024-465-1	COASTER (S) ASSY
767	2-342-612-01	RAIL
768	3-703-816-13	SCREW (M1.4X2.0), SPECIAL HEAD
769	X-2024-466-1	COASTER (T) ASSY
770	X-2024-469-1	ARM (T) ASSY, GL
771	2-342-716-01	SPRING (T), TORSION COIL
772	3-703-816-08	SCREW (M1.4X1.4), SPECIAL HEAD (for adjustment)

5. REPAIR PARTS LIST

5-1-10. LS/MECHANICAL CHASSIS BLOCK ASSEMBLY-2

ns : not supplied

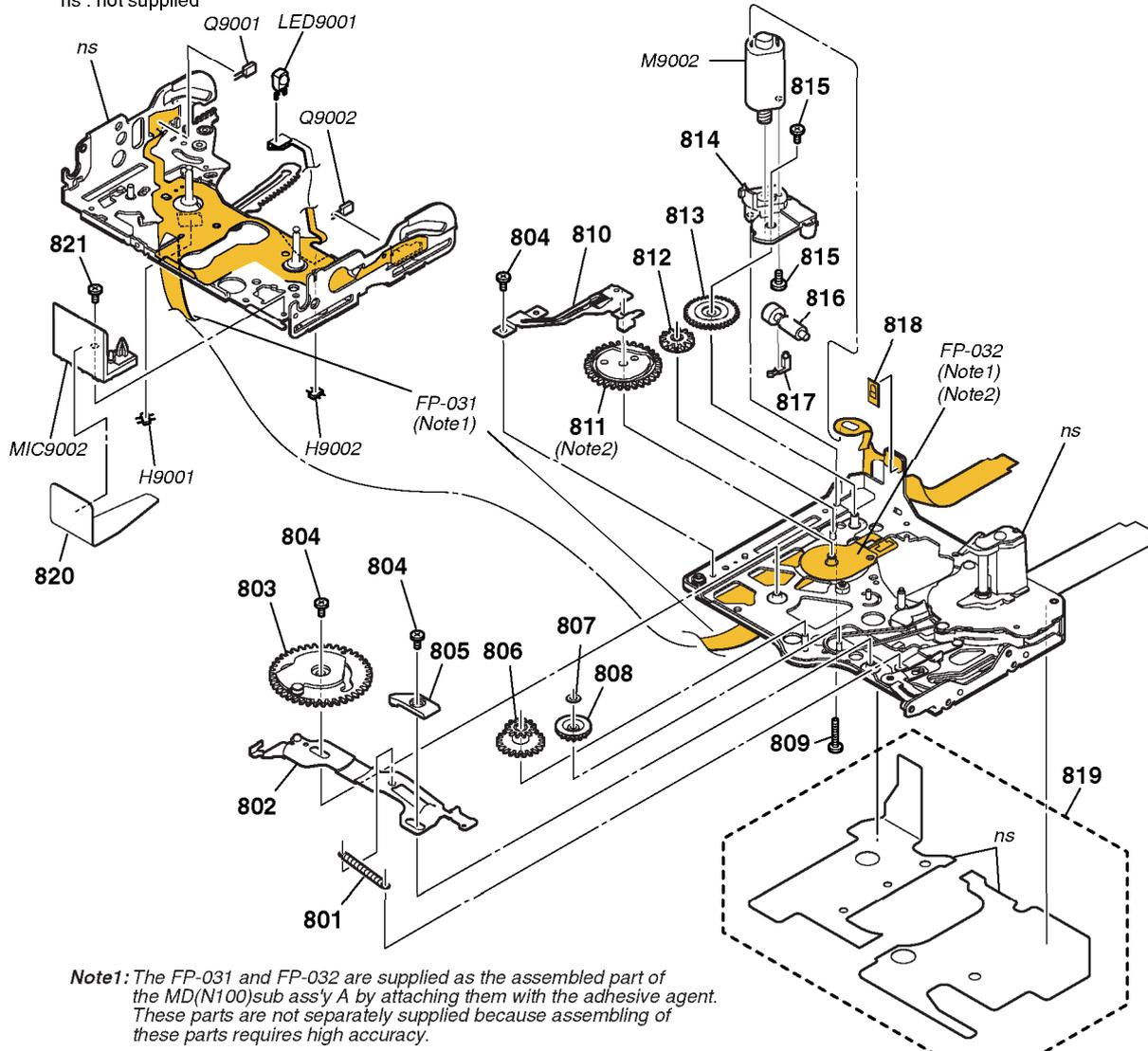

Note1: The FP-031 and FP-032 are supplied as the assembled part of the MD(N100) sub ass'y A by attaching them with the adhesive agent. These parts are not separately supplied because assembling of these parts requires high accuracy.

Note2: The mode switch (S9003) function works when the contactor of the FP-032 contacts with the bottom surface of wiper of the mode gear ass'y.

Ref. No.	Part No.	Description	Ref. No.	Part No.	Description
801	2-342-624-01	SPRING (PINCH LIMITTER), EXTEN	815	3-895-822-71	SCREW (M1.2X1.5), SPECIAL, 0
802	X-2024-463-1	SLIDER ASSY, MODE	816	2-342-689-01	WORM SHAFT (2J)
803	X-2024-462-1	GEAR ASSY, CAM	817	2-342-690-01	BASE, MOTOR HOLDER
804	3-075-097-11	SCREW (M1.4X1.4), SPECIAL HEAD	818	1-677-049-11	FP-228 FLEXIBLE BOARD (DEW SENSOR)
805	2-342-625-01	RETAINER, LEVER EJ	819	2-342-686-01	COVER, CAPSTAN
806	2-342-621-01	GEAR, RELAY	820	2-541-984-01	MIC COVER
807	3-315-414-31	WASHER	821	3-703-816-13	SCREW (M1.4X2.0), SPECIAL HEAD
808	2-342-620-01	GEAR, CONVERSION	LED9001	6-500-652-01	DIODE GL453SE000F (TAPE LED)
809	3-084-377-01	HEAD (SCREW M1.2)	H9001	8-719-067-74	ELEMENT, HOLE HW-105A-CDE-T (S REEL)
810	X-2024-460-1	BASE ASSY, CAM	H9002	8-719-067-74	ELEMENT, HOLE HW-105A-CDE-T (T REEL)
811	X-2024-461-1	GEAR ASSY, MODE	M9002	X-2024-464-1	MOTOR ASSY (LOADING)
812	2-342-615-01	GEAR, NO.2	MIC9002	1-818-576-11	PIN, CONNECTOR (WITH DETECTION SWITCH)
813	2-342-691-01	GEAR, NO.1	Q9001	6-550-672-01	TRANSISTOR PT4850FJE00F (TAPE END)
814	2-342-688-01	MOTOR HOLDER	Q9002	6-550-672-01	TRANSISTOR PT4850FJE00F (TAPE TOP)

5. REPAIR PARTS LIST

• **EXCEPT J MODEL**

Checking supplied accessories.

to J MODEL

Make sure that the following accessories are supplied with your camcorder.

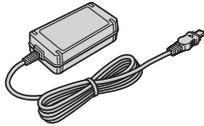

AC Adaptor (1)
▲ 1-479-047-11



Wireless Remote Commander (RMT-831) (1)
1-477-898-41



CD-ROM "Picture Package Ver. 1.5" (SPVD-012 2005) (1)
2-515-350-01



Rechargeable battery pack (NP-FA50) (1)
(not supplied)



Power cord (Main lead) (1) (US, CND model)
▲ 1-790-107-41



A/V connecting cable (1)
1-823-156-51

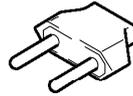

2-pin conversion adaptor (1) (JE model)
1-569-007-12



"Memory Stick Duo" (16MB) (1)
(not supplied)

Power cord (Main lead) (1) (AEP, E, NE model)
▲ 1-769-608-31

Power cord (Main lead) (1) (UK, HK model)
▲ 1-783-374-12

Power cord (Main lead) (1) (KR model)
▲ 1-776-985-11

Power cord (Main lead) (1) (AUS model)
▲ 1-827-945-12

Power cord (Main lead) (1) (JE model)
▲ 1-790-732-71

Power cord (Main lead) (1) (CH model)
▲ 1-782-476-51



USB cable (1)
1-829-868-31

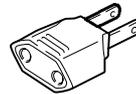

2-pin conversion adaptor (1) (E, HK model)
1-569-008-21



Memory Stick Duo adaptor (1)
(not supplied)



Shoulder strap (1)
2-176-235-01

- Abbreviation
- CND : Canadian model
- AUS : Australian model
- NE : North European model
- CH : Chinese model
- HK : Hong Kong model
- KR : Korea model
- JE : Tourist model

Other accessories

- 2-548-307-11 MANUAL, INSTRUCTION (ENGLISH)(HC90:US,CND,E,JE)
- 2-548-307-21 MANUAL, INSTRUCTION (FRENCH)(HC90:CND)
- 2-548-307-31 MANUAL, INSTRUCTION (SPANISH)(HC90:E,JE)
- 2-548-307-41 MANUAL, INSTRUCTION (PORTUGUESE)(HC90:E,JE)
- 2-548-307-51 MANUAL, INSTRUCTION (TRADITIONAL CHINESE)
(HC90:E)
- 2-548-307-61 MANUAL, INSTRUCTION (KOREAN)(HC90:KR,JE)
- 2-548-308-11 MANUAL, INSTRUCTION (ENGLISH)
(HC90E:AEP,UK,E,AUS,HK,JE)
- 2-548-308-21 MANUAL, INSTRUCTION (FRENCH)(HC90E:AEP,E)
- 2-548-308-31 MANUAL, INSTRUCTION (SPANISH/PORTUGUESE)
(HC90E:AEP)
- 2-548-308-41 MANUAL, INSTRUCTION (ITALIAN/GREEK)(HC90E:AEP)

- 2-548-308-51 MANUAL, INSTRUCTION (GERMAN/DUTCH)(HC90E:AEP)
- 2-548-308-61 MANUAL, INSTRUCTION (SWEDISH/RUSSIAN)
(HC90E:JE,NE)
- 2-548-308-71 MANUAL, INSTRUCTION (DANISH/FINNISH)(HC90E:NE)
- 2-548-308-81 MANUAL, INSTRUCTION (ARABIC/PERSIAN)(HC90E:E)
- 2-548-308-91 MANUAL, INSTRUCTION (TRADITIONAL CHINESE)
(HC90E:HK)
- 2-582-532-11 MANUAL, INSTRUCTION (SIMPLIFIED CHINESE)
(HC90E:E,JE,CH)

<p>Note : The components identified by mark ▲ or dotted line with mark ▲ are critical for safety. Replace only with part number specified.</p>	<p>Note : Les composants identifiés par une marque ▲ sont critiques pour la sécurité. Ne les remplacer que par une pièce portant le numéro spécifié.</p>
-----------------------------------------------------------------------------------------------------------------------------------------------------------	---------------------------------------------------------------------------------------------------------------------------------------------------------------------

5. REPAIR PARTS LIST

• J MODEL

付属品

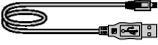
 <p>ACアダプター (1) △1-479-047-11</p>	 <p>AV接続ケーブル (1) 1-823-156-51</p>	 <p>リチャージャブルバッテリーパック (NP-FA50) (1) (供給せず)</p>
 <p>電源コード (1) △1-790-732-71</p>	 <p>USBケーブル (1) 1-829-868-31</p>	 <p>“メモリスティック デュオ” (16MB) (1) (供給せず)</p>
<div style="border: 1px dashed black; padding: 5px; display: inline-block;">  <p>リモコン電池蓋 (3-083-973-01)</p> </div> <p>ワイヤレスリモコン (RMT-831) (1) 1-477-898-51</p>	 <p>CD-ROM 「Picture Package Ver. 1.5」 (SPVD-012 2005) (1) 2-515-350-01</p>	 <p>メモリスティック デュオ アダプター (1) (供給せず)</p>
<p>図面 番号</p>	<p>部品コード 部 品 名</p> <p>2-548-307-01 取扱説明書</p>	<p>△印の部品、または△印付の点線で囲まれた部品は、安全性を維持するために、重要な部品です。従って交換時は、必ず指定の部品を使用してください。</p>

5-2. ELECTRICAL PARTS LIST

Ref. No.	Part No.	Description
	A-1084-128-A	FP-063 FLEXIBLE BOARD, COMPLETE *****
		< CONNECTOR >
CN001	1-780-195-11	BATTERY TERMINAL BOARD < SWITCH >
S001	1-786-680-21	SWITCH, DETECTION (SMD) (PANEL OPEN/CLOSE)
	A-1084-129-A	FP-064 FLEXIBLE BOARD, COMPLETE *****
		< CONNECTOR >
CN001	1-817-913-11	MEMORY STICK DUO CONNECTOR
	A-1084-130-A	FP-066 FLEXIBLE BOARD, COMPLETE *****
		< SWITCH >
S001	1-786-680-21	SWITCH, DETECTION (SMD) (PANEL POSITION)
	A-1084-131-A	FP-068 FLEXIBLE BOARD, COMPLETE *****
		< CONNECTOR >
CN001	1-794-962-11	CONNECTOR, SQUARE TYPE (USB 5P)
CN002	1-794-276-11	CONNECTOR, SQUARE TYPE 4P (DV)
	A-1084-125-A	JK-280 BOARD, COMPLETE *****
		< CAPACITOR >
C8102	1-125-777-11	CERAMIC CHIP 0.1uF 10% 10V
C8103	1-125-777-11	CERAMIC CHIP 0.1uF 10% 10V
C8104	1-125-777-11	CERAMIC CHIP 0.1uF 10% 10V
C8105	1-125-777-11	CERAMIC CHIP 0.1uF 10% 10V
		< CONNECTOR >
CN8101	1-815-794-21	CONNECTOR (MULTIPLE)
CN8102	1-818-320-11	CONNECTOR, FPC (ZIF) 39P
		< DIODE >
D8103	6-500-776-01	DIODE MAZW068H0LS0 < FERRITE BEAD >
FB8103	1-414-760-21	BEAD, FERRITE (CHIP) (1608)
FB8104	1-500-444-11	FERRITE, EMI (SMD) (1608)
FB8105	1-414-760-21	BEAD, FERRITE (CHIP) (1608)
FB8106	1-500-444-11	FERRITE, EMI (SMD) (1608)
FB8107	1-500-444-11	FERRITE, EMI (SMD) (1608)
FB8108	1-500-444-11	FERRITE, EMI (SMD) (1608)
FB8109	1-500-444-11	FERRITE, EMI (SMD) (1608)
FB8110	1-500-444-11	FERRITE, EMI (SMD) (1608)
FB8111	1-500-444-11	FERRITE, EMI (SMD) (1608)

Ref. No.	Part No.	Description
		< JACK >
J8102	1-815-792-11	CONNECTOR, DC-IN (7.2V) (DC-IN)
J8103	1-793-995-11	JACK, SUPER SMALL TYPE (LANC)
		< LINE FILTER >
LF8101	1-456-681-21	COIL, CHOKE
		< RESISTOR >
R001	1-240-683-91	METAL CHIP 100 5% 1/20W
R002	1-240-683-91	METAL CHIP 100 5% 1/20W
		< VARISTOR >
VDR812	1-803-974-21	VARISTOR, CHIP (1608)
VDR813	1-803-974-21	VARISTOR, CHIP (1608)
VDR814	1-803-974-21	VARISTOR, CHIP (1608)
VDR815	1-803-974-21	VARISTOR, CHIP (1608)
VDR816	1-803-974-21	VARISTOR, CHIP (1608)
	A-1084-127-A	PD-240 BOARD, COMPLETE *****
		< CAPACITOR >
C7502	1-164-939-11	CERAMIC CHIP 0.0022uF 10% 50V
C7503	1-125-777-11	CERAMIC CHIP 0.1uF 10% 10V
C7504	1-165-799-11	TANTAL. CHIP 22uF 20% 4V
C7507	1-165-908-11	CERAMIC CHIP 1uF 10% 10V
C7509	1-125-777-11	CERAMIC CHIP 0.1uF 10% 10V
C7510	1-125-777-11	CERAMIC CHIP 0.1uF 10% 10V
C7511	1-164-739-11	CERAMIC CHIP 560PF 5% 50V
C7512	1-164-943-11	CERAMIC CHIP 0.01uF 10% 16V
C7513	1-164-943-11	CERAMIC CHIP 0.01uF 10% 16V
C7514	1-164-943-11	CERAMIC CHIP 0.01uF 10% 16V
C7515	1-137-700-11	TANTAL. CHIP 10uF 20% 6.3V
C7516	1-165-908-11	CERAMIC CHIP 1uF 10% 10V
C7517	1-165-908-11	CERAMIC CHIP 1uF 10% 10V
C7519	1-127-760-11	CERAMIC CHIP 4.7uF 10% 6.3V
C7520	1-127-760-11	CERAMIC CHIP 4.7uF 10% 6.3V
C7521	1-125-777-11	CERAMIC CHIP 0.1uF 10% 10V
C7522	1-165-908-11	CERAMIC CHIP 1uF 10% 10V
C7524	1-164-943-11	CERAMIC CHIP 0.01uF 10% 16V
C7525	1-165-908-11	CERAMIC CHIP 1uF 10% 10V
C7526	1-125-777-11	CERAMIC CHIP 0.1uF 10% 10V
C7527	1-125-777-11	CERAMIC CHIP 0.1uF 10% 10V
C7533	1-125-777-11	CERAMIC CHIP 0.1uF 10% 10V
		< CONNECTOR >
CN7501	1-794-410-11	CONNECTOR, FPC (ZIF) 27P
CN7502	1-794-322-11	CONNECTOR, FFC/FPC (ZIF) 6P
CN7503	1-794-322-11	CONNECTOR, FFC/FPC (ZIF) 6P
CN7505	1-785-905-11	CONNECTOR, FFC/FPC (ZIF) 24P
CN7506	1-794-322-11	CONNECTOR, FFC/FPC (ZIF) 6P
		< DIODE >
D7502	8-719-074-67	DIODE EDZ-TE61-5.6B
D7503	8-719-056-23	DIODE MA2S111-(K8).S0

Ref. No.	Part No.	Description
		< FERRITE BEAD >
FB7501	1-414-760-21	FERRITE, EMI (SMD) (1608)
		< IC >
IC7501	8-753-229-95	IC CXM3006CER-T4
		< COIL >
L7501	1-400-137-11	INDUCTOR 10uH
L7502	1-400-137-11	INDUCTOR 10uH
L7503	1-400-137-11	INDUCTOR 10uH
L7504	1-400-137-11	INDUCTOR 10uH
		< TRANSISTOR >
Q7501	8-729-427-53	TRANSISTOR XP4216-TXE
Q7502	8-729-427-23	TRANSISTOR XP4116-TXE
Q7507	6-550-119-01	TRANSISTOR DTC144EMT2L
Q7508	6-550-232-01	TRANSISTOR 2SA2029T2LQ/R
Q7509	8-729-041-23	TRANSISTOR NDS356AP
Q7513	8-729-042-26	TRANSISTOR 2SB1462J-QR (K8).SO
Q7514	8-759-054-48	IC C010-PW2000SV-V110
Q7515	8-759-054-48	IC C010-PW2000SV-V110
Q7516	8-729-037-61	TRANSISTOR UN9113J-(TX).SO
		< RESISTOR >
R7501	1-216-864-11	SHORT CHIP 0
R7504	1-216-864-11	SHORT CHIP 0
R7506	1-218-990-11	SHORT CHIP 0
R7507	1-208-695-11	METAL CHIP 3.3K 0.5% 1/16W
R7508	1-208-691-11	METAL CHIP 2.2K 0.5% 1/16W
R7509	1-218-990-11	SHORT CHIP 0
R7510	1-218-975-11	RES-CHIP 68K 5% 1/16W
R7512	1-218-949-11	RES-CHIP 470 5% 1/16W
R7513	1-218-990-11	SHORT CHIP 0
R7514	1-208-934-11	METAL CHIP 91K 0.5% 1/16W
R7516	1-208-911-11	METAL CHIP 10K 0.5% 1/16W
R7523	1-218-969-11	RES-CHIP 22K 5% 1/16W
R7528	1-218-953-11	RES-CHIP 1K 5% 1/16W
R7529	1-218-977-11	RES-CHIP 100K 5% 1/16W
R7530	1-218-978-11	RES-CHIP 120K 5% 1/16W
R7532	1-218-989-11	RES-CHIP 1M 5% 1/16W
R7533	1-218-989-11	RES-CHIP 1M 5% 1/16W
R7537	1-218-969-11	RES-CHIP 22K 5% 1/16W
R7538	1-218-963-11	RES-CHIP 6.8K 5% 1/16W
R7539	1-218-950-11	RES-CHIP 560 5% 1/16W
R7540	1-218-969-11	RES-CHIP 22K 5% 1/16W
R7541	1-208-643-11	METAL CHIP 22 0.5% 1/16W
R7542	1-218-959-11	RES-CHIP 3.3K 5% 1/16W
R7543	1-218-953-11	RES-CHIP 1K 5% 1/16W
R7545	1-218-955-11	RES-CHIP 1.5K 5% 1/16W
R7546	1-218-954-11	RES-CHIP 1.2K 5% 1/16W
R7551	1-218-953-11	RES-CHIP 1K 5% 1/16W
R7554	1-220-803-81	RES-CHIP 4.7 5% 1/16W
R7555	1-220-803-81	RES-CHIP 4.7 5% 1/16W
		< COMPOSITION CIRCUIT BLOCK >
RB7501	1-234-369-21	RES, NETWORK 10 (1005X4)

Ref. No.	Part No.	Description
	A-1084-126-A	ST-114 BOARD, COMPLETE *****
		< CAPACITOR >
C8401	1-125-837-91	CERAMIC CHIP 1uF 10% 6.3V
C8402	1-165-908-11	CERAMIC CHIP 1uF 10% 10V
C8403	1-165-875-11	CERAMIC CHIP 10uF 10% 10V
△ C8404	1-112-076-11	ELECT 43uF 99% 330V
△ C8405	1-112-076-11	ELECT 43uF 99% 330V
		< CONNECTOR >
CN8401	1-816-646-31	FFC/CONNECTOR, FPC (LIF) 16P
CN8402	1-817-550-11	CONNECTOR, FPC (LIF (NON-ZIF)) 18P
		< DIODE >
△ D8401	6-501-096-01	DIODE CRF02 (TE85R)
		< IC >
IC8401	6-707-554-01	IC TPS65552DGQR
		< COIL >
L8401	1-412-027-11	INDUCTOR 2.2uH
		< TRANSISTOR >
Q8401	6-550-656-01	TRANSISTOR CY25BAJ-8F-T23
		< RESISTOR >
R8401	1-216-803-11	METAL CHIP 33 5% 1/10W
R8402	1-216-857-11	METAL CHIP 1M 5% 1/10W
R8403	1-208-935-11	METAL CHIP 100K 0.5% 1/16W
R8406	1-208-947-11	METAL CHIP 330K 0.5% 1/16W
		< TRANSFORMER >
△ T8401	1-443-568-21	TRANSFORMER, D.C.-D.C.CONVERTER

The components identified by mark △ or dotted line with mark △ are critical for safety.
Replace only with part number specified.

Les composants identifiés par une marque △ sont critiques pour la sécurité.
Ne les remplacer que par une pièce portant le numéro spécifié.

△印の部品、または△印付の点線で囲まれた部品は、安全性を維持するために、重要な部品です。
従って交換時は、必ず指定の部品を使用してください。

CD-540

CK-145

IR-055

LD-176

VC-380

<u>Ref. No.</u>	<u>Part No.</u>	<u>Description</u>
		CD-540 BOARD, COMPLETE *****



		CK-145 BOARD, COMPLETE *****
--	--	---------------------------------



		IR-055 BOARD, COMPLETE *****
--	--	---------------------------------



		LD-176 BOARD, COMPLETE *****
--	--	---------------------------------



		VC-380 BOARD, COMPLETE *****
--	--	---------------------------------



Electrical parts list of the CD-540, CK-145, IR-055, LD-176 and VC-380 board are not shown. Pages from 5-17 to 5-27 are not shown.