



## Service-Information

### Einbauherd AKP 152/IX

8577 152 29500

Letzte Änderung: 30.03.2010

Anlagedatum: 09.05.2008

---

<b>Ersatzteilliste</b>	<b>2</b>
<b>Explosionszeichnung</b>	<b>3</b>
<b>Technische Daten</b>	<b>4</b>
<b>Einbauskizze</b>	<b>5</b>
<b>Anschlußplan</b>	<b>6</b>

---

Die vorliegenden Serviceunterlagen sind ausschließlich für technisch qualifizierte Fachkräfte bestimmt, welche mit den entsprechenden einschlägigen Sicherheitsvorschriften vertraut sind.

Änderungen vorbehalten

**Ersatzteilliste**

<b>Pos-Nr.</b>	<b>12NC</b>	<b>Beschreibung</b>
040 0	<b>4812 417 19339</b>	Scharnier
047 0	<b>4812 417 19137</b>	Zugrollenhalter
110 0	<b>4812 498 68259</b>	Tuergriff
121 3	<b>4812 460 58418</b>	Dampfsperrblech
141 0	<b>4812 450 59953</b>	Tuerscheibe + Halter
142 0	<b>4812 450 59576</b>	Scheibe innen
143 1	<b>4812 404 49841</b>	Traeger Glas
191 0	<b>4812 466 88874</b>	Tuerdichtung
201 0	<b>4812 442 69504</b>	Rueckwand
204 0	<b>4812 442 69782</b>	Seitenwand emailliert katalytisch
245 0	<b>4812 458 19334</b>	Bratrost
247 0	<b>4812 418 38138</b>	Fettpfanne
248 0	<b>4812 535 78072</b>	Drehspiess Set
248 1	<b>4812 458 19146</b>	Rost Drehspiess
261 0	<b>4812 458 19304</b>	Einhaengegitter links
261 1	<b>4812 458 19303</b>	Einhaengegitter rechts
301 0	<b>4812 452 40274</b>	Schalterblende AMPERE
332 0	<b>4812 410 78186</b>	Druckknopf Ampere
334 0	<b>4812 412 78899</b>	Knopf
350 0	<b>4812 130 18696</b>	Display Ampere
400 0	<b>4812 361 68002</b>	Motor
440 0	<b>4812 361 18604</b>	Lueftermotor
441 0	<b>4812 361 18527</b>	Luefter Kuehlung
443 0	<b>4819 515 48065</b>	Luefterrad
452 0	<b>4812 259 98519</b>	Heizelement Oberhitze/Grill
456 0	<b>4812 259 98517</b>	Heizelement Unterhitze 230V
490 1	<b>4812 290 68255</b>	Kabelschelle
490 2	<b>4812 316 18036</b>	Kabelschutz
491 0	<b>4812 290 68329</b>	Anschlussblock
521 0	<b>4812 214 58615</b>	Bedienungseinheit
554 0	<b>4812 282 08669</b>	Thermostat
557 0	<b>4812 282 28209</b>	Temperaturbegr.
557 1	<b>4812 282 28329</b>	Temperaturbegr. 3-fach
557 2	<b>4812 282 28282</b>	Temperaturbegrenzer
620 0	<b>4812 273 18106</b>	Backofenschalt.
651 0	<b>4819 134 88153</b>	Lampe Herd 25W 230V
652 0	<b>4819 255 18237</b>	Lampenfassung hinten
656 0	<b>4812 450 28007</b>	Lampenglas hinten
914 0	<b>4812 505 18421</b>	Mutter M4
915 0	<b>4819 505 18145</b>	Mutter Luefterfluegel
930 0	<b>4812 404 18649</b>	Befestigungsklammer Thermostat
932 0	<b>4819 492 68714</b>	Feder
993 0	<b>4812 310 39061</b>	Distanzstueck

## Explosionszeichnung

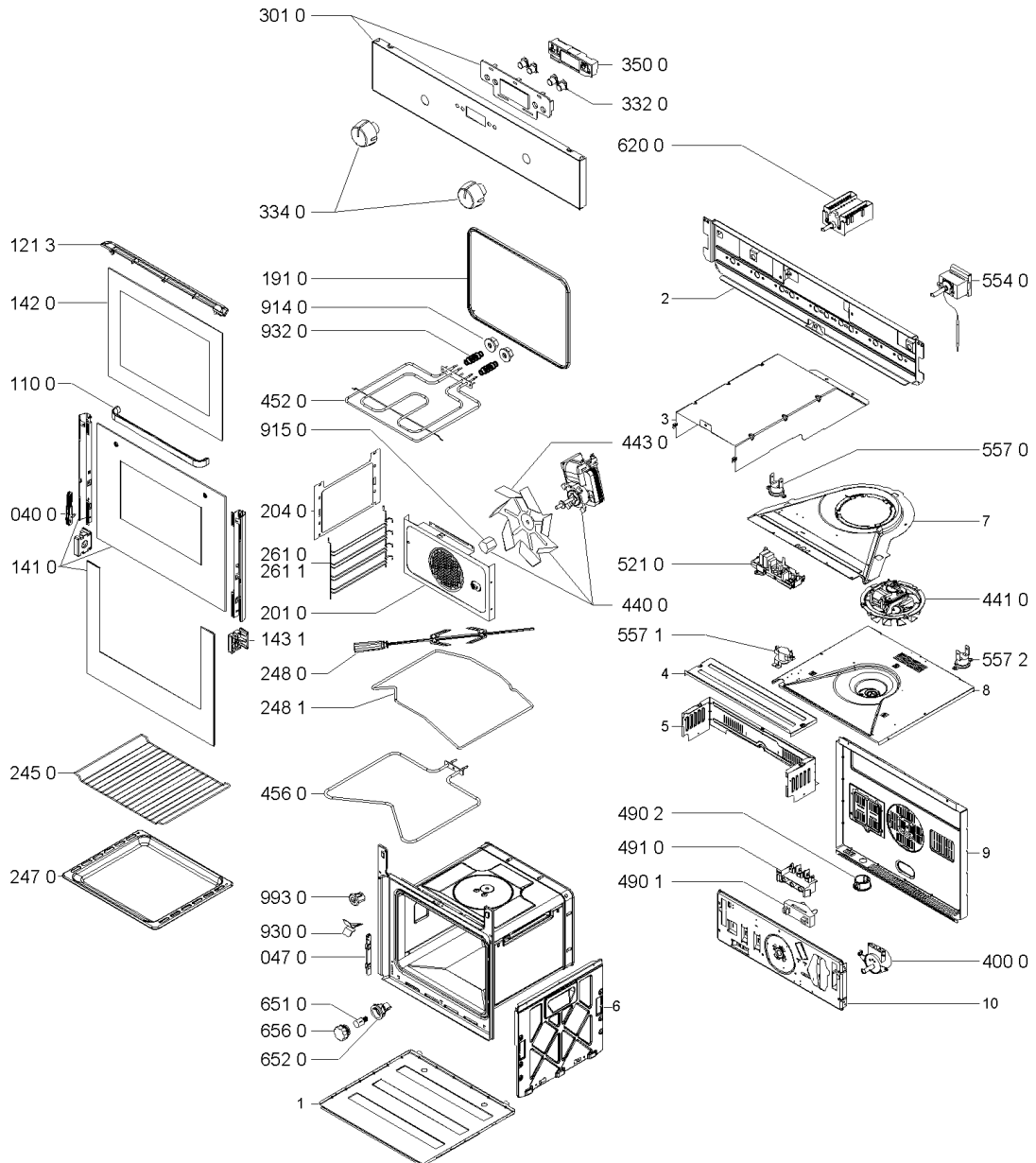

0000 006 01655

## Technische Daten

### Elektrische Basisdaten

Betriebsspannung ..... 230 V~  
Netzanschluß ..... 230 V 1N~50 Hz

### Anschlusswert

Gesamtanschlusswert ..... 2500 W  
Oberhitzeheizkörper/Grill ..... 900 / 2500 W  
Unterhitzeheizkörper ..... 1150 W

### Elektrische Bauteile

Auto timer ..... Ampere

### Zubehör

Fettpfanne emailliert ..... 375 x 445.5 mm  
Backrost Chrom ..... 446.5 x 340 mm

## Einbauskizze

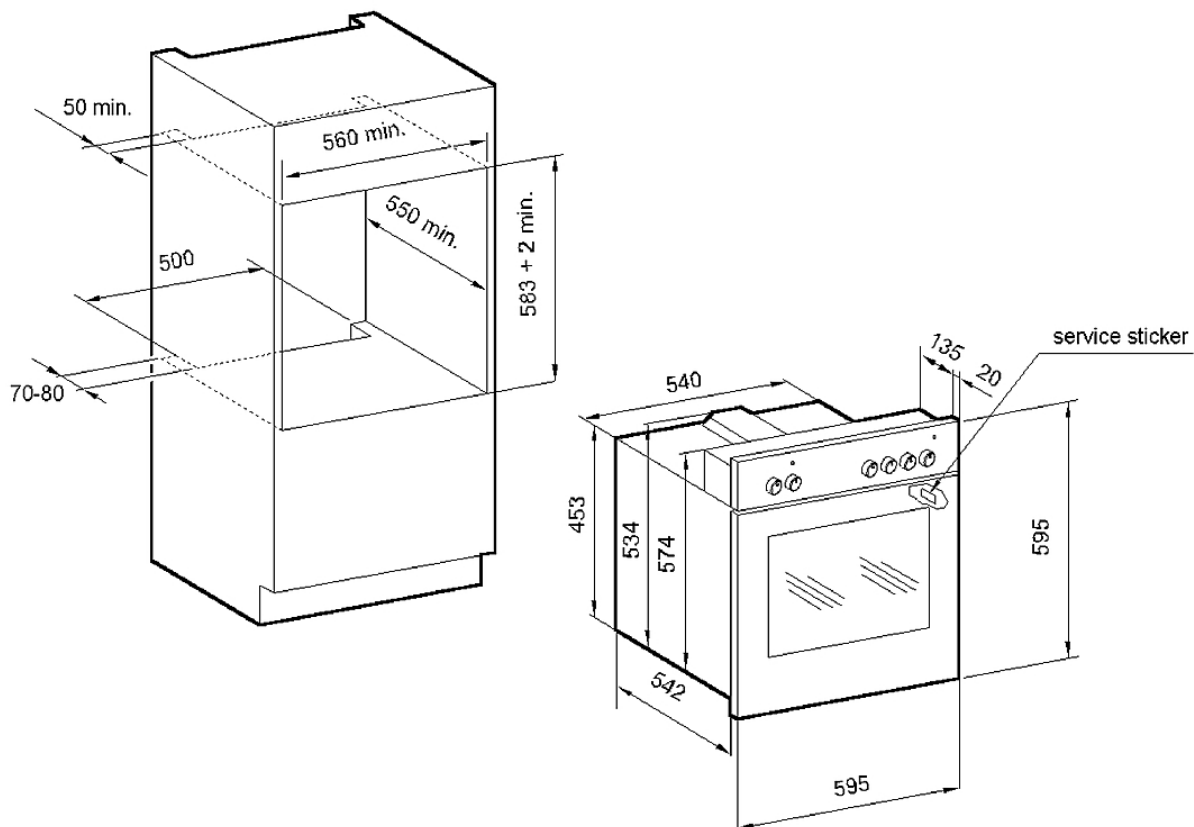





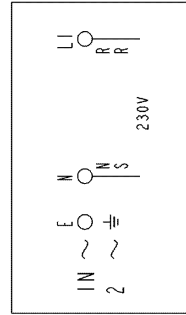
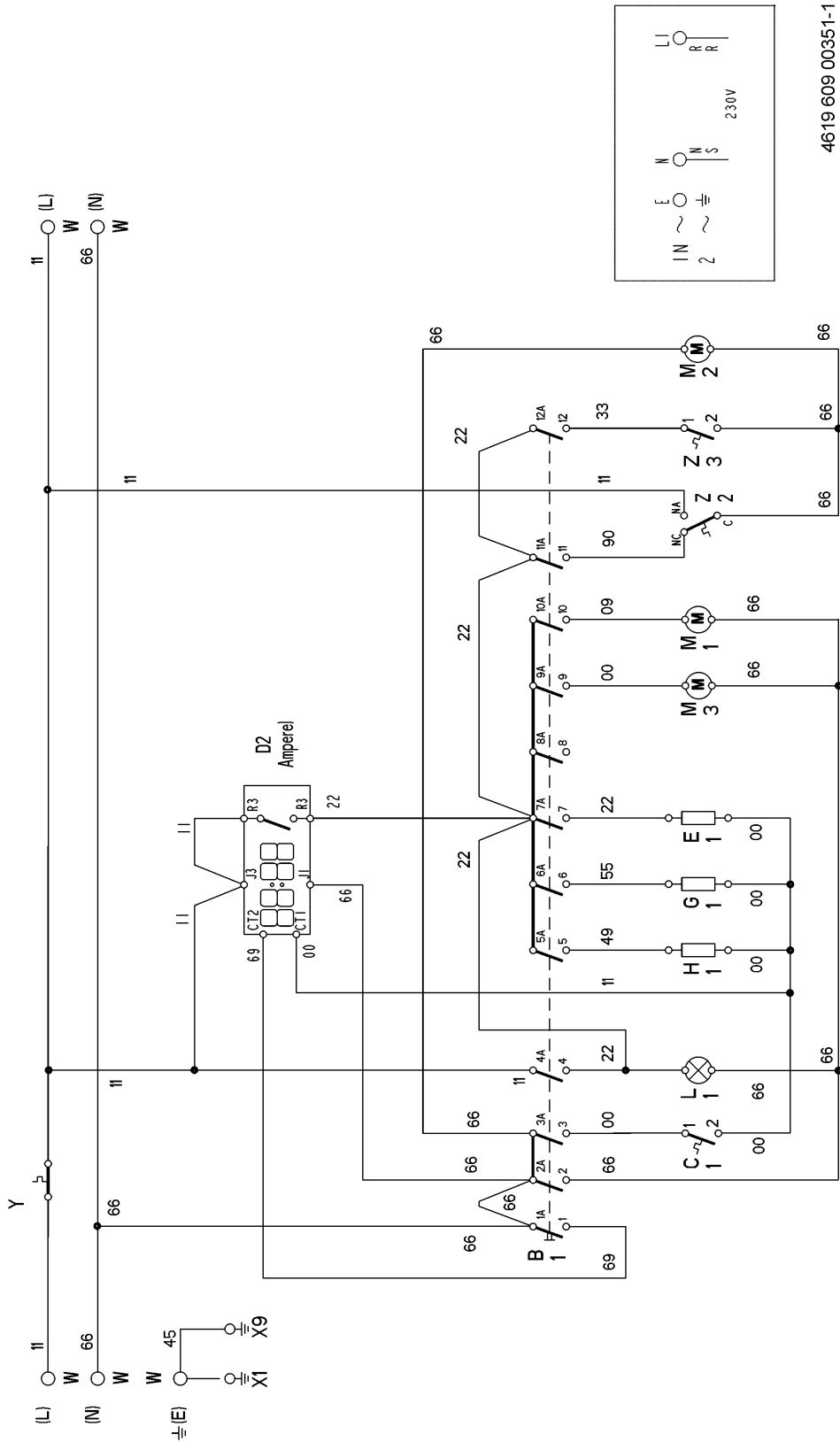

































Z8100132

## Anschlußplan



4619 609 00351-1

## Anschlußplan

							
	0	1	2	3	4	5	6
 P1-1 			X	X	X	X	X
 P2-2 		X	X	X	X	X	X
 P3-3 			X	X	X	X	X
 P4-4 		X					
 P5-5 			X	X			
 P6-6 			X	X	X	X	
 P7-7 					X	X	
 P8-8 			X	X	X	X	
 P9-9 					X	X	
 P10-10 				X		X	X
 P11-11 			X		X	X	
 P12-12 				X			
<b>B1</b> 4619 615 15071							

4619 609 00351\_2

## Legende

B1 OVEN SELECTOR  
C1 OVEN THERMOSTAT  
D2 ELECTRONIC TIMER (AMPERE)  
E1 GRILL HEATING EL.  
G1 UPPER HEATING EL.  
H1 LOWER HEATING EL.  
L1 OVEN LAMP  
M1 CAVITY FAN  
M2 COOLING FAN  
M3 TURNSPIT  
Y THERMOFUSE  
Z2 COOLING FAN THERMOLIMITER  
Z3 A - CLASS THERMOLIMITER  
W MAINS TERMINAL BLOCK  
X1 EARTHING CABINET  
X9 EARTHING UPPER/GRILL H.E

00 BLACK  
11 BROWN  
22 RED  
33 ORANGE  
44 YELLOWJ  
55 GREEN  
66 BLUE  
77 VIOLET  
88 BLUE SKY  
99 WHITE  
09 WHITE - BLACK  
29 WHITE - RED  
49 WHITE - YELLOW  
69 WHITE - BLUE  
90 GREY  
45 YELLOW - GREEN

**60900351en**